

M550

SOLAR POWERED LED MARINE LANTERN, 1 TO 3 NM RANGE

Leveraging custom optics, high-efficiency solar panels, and premium materials, this miniature solar LED marine lantern offers up to three times the range at half the size of its M502 predecessor. Now with replaceable, recyclable batteries this lantern provides excellent value and reliable operation over the long term. Battery life expectancy is five years with product life up to 15 years and a three-year warranty. Ideal for marine aids-to-navigation, marina lighting, dock lighting, and port lighting.

To view performance in your installation location, visit www.carmanahmarine.com/selector.

- 40 user-adjustable flash patterns and programmable intensities
- Replaceable, recyclable, high-temperature-rated NiMH AA batteries
- Automatic Light Control (ALC) 2.0; achieve optimal intensities throughout the year
- Premium grade, UV resistant polycarbonate body and lens material
- IP 68 rated
- Ventilated battery compartment

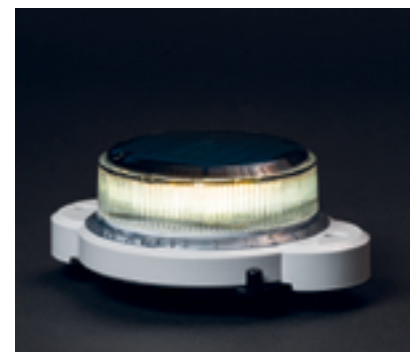
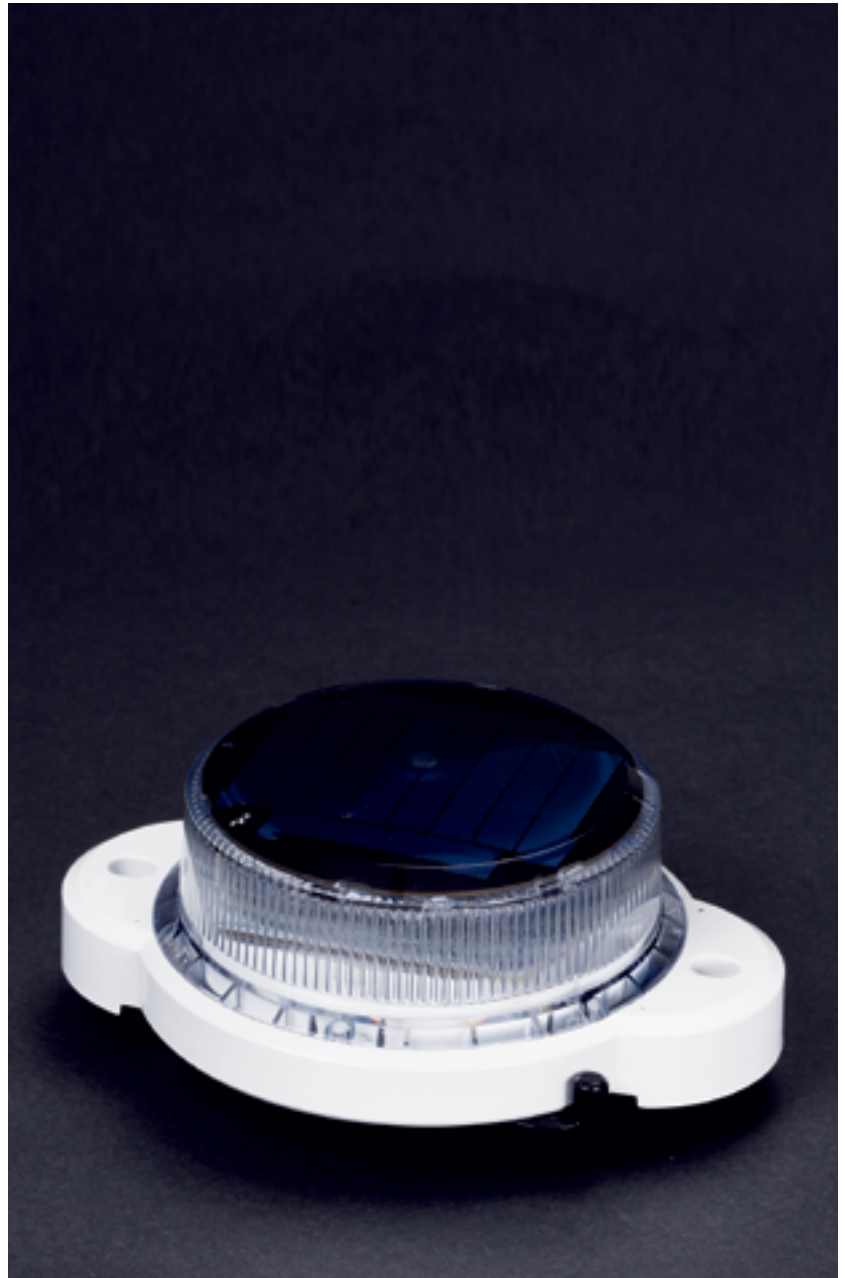

SABIK
a Carmanah company



SOLAR MODULES

High-efficiency cells embedded in shatterproof polyurethane.

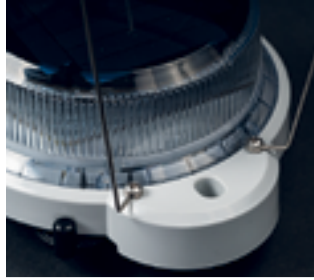

BIRD DETERRENT

Stainless steel bird deterrent available as accessory. Fits up to four per lantern.

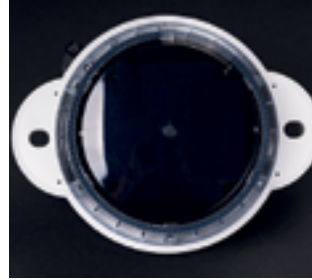

INSTALLATION

Simple installation using 2 x M6 bolts on a 127 mm diameter. No additional mounting hardware required.



POLE MOUNT

Easily adjusts to 2 3/8 inch, 60mm or 1 7/8 inch, 48 mm pole dimensions.



BATTERIES

Replaceable and recyclable NiMH batteries with extreme temperature range and 5-year life expectancy.



IR CONTROLLER

Check battery status, change flash code, adjust light intensity and turn lantern off with optional mini IR (Infrared) programmer.



EXTERNAL SWITCH

Optional external ON/OFF switch.

TECHNICAL SPECIFICATION M550

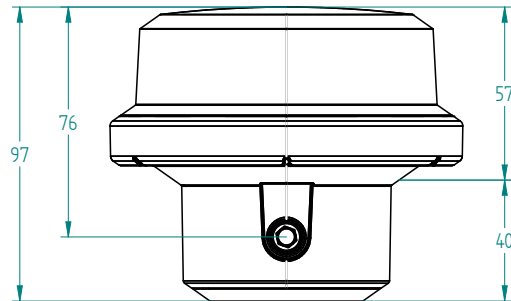
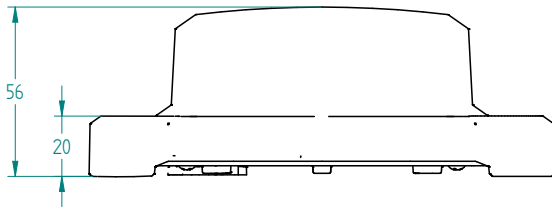
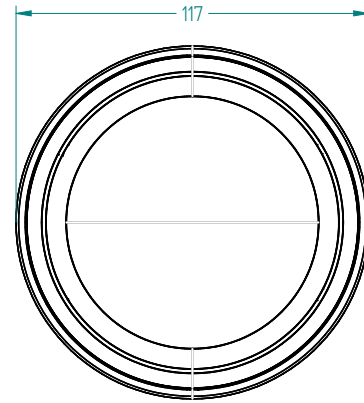
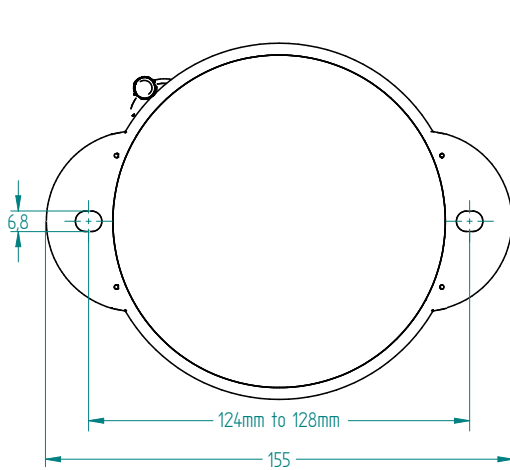

OPTICAL PERFORMANCE				
Maximum fixed intensity				
18 cd	23 cd	29 cd	25 cd	8 cd

Note: Peak IALA intensity dependent on location. To view performance in your installation location, visit www.carmanahmarine.com/selector.

MAIN TECHNICAL SPECIFICATION

Construction	Premium grade, UV resistant polycarbonate lens/head and polycarbonate/polysiloxane co-polymer base.
Lens visual/Mechanical diameter	102 mm
Lens material	UV stabilized polycarbonate
Light source	High Flux Surface Mount LED
Solar module	High efficiency cells
Battery	NiMH AA batteries
Degree of ingress protection	IP 68
Weight	Flange Mount: 0.37 kg (0.8 lbs) Pole Mount: 0.40 kg (0.9 lbs)
Overall height	56 mm (flange mount), 96 mm (pole mount)
Overall width	155 mm dia.
Installation	2 x M6 on 128 mm dia.

ORDER OVERVIEW M550

OPTION MATRIX

M550 Flange Mount - Switched	2-bolt mount with ON/OFF switch
M550 Flange Mount - Unswitched	2-bolt mount. No ON/OFF switch
M550 Pole Mount	Pole mount. No ON/OFF switch

ACCESSORIES

69935	Pole Mount Replacement/Conversion Kit
70943	Flange Mount Replacement/Conversion Kit
70937	Switched Kit (compatible with Flange Mount only)
70955	Replacement NiMH batteries
69934	Bird Deterrent (single)

PRODUCT CODES

Colour	M550 Flange unswitched	M550 Flange switched	M550 Pole
red	M550RF	M550RF-S	M550RP
green	M550GF	M550GF-S	M550GP
white	M550WF	M550WF-S	M550WP
yellow	M550YF	M550YF-S	M550YP
blue	M550BF	M550BF-S	M550BP