

ROPEBLOCK²⁰²³ CATALOG

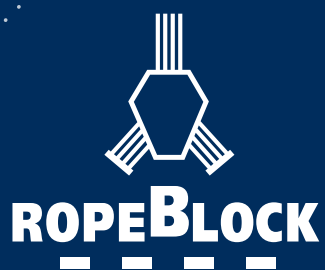
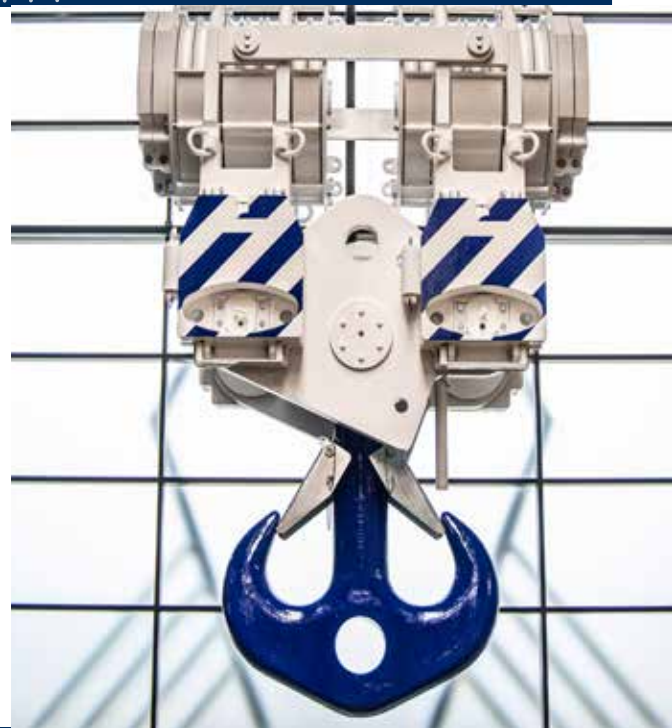

DISCLAIMER

Your Ropeblock product is by default considered a tool or essential part of the intended application and therefore defined by the application or system designer or application owner. In accordance with Machine Directive 2006/42/EC, this Ropeblock product is therefore supplied as standard without EC declaration. Where applicable, the product will become part of a CE-marked assembly. The product must then not be put into service until the full assembly has been declared to conform to the provisions of 2006/42/EC. Where the product is considered a lifting accessory, requiring an individual conformity declaration (IIA) or declaration of incorporation (IIB), it shall be mentioned in the contract.

The party installing Ropeblock products shall be competent and qualified in the design, construction or maintenance of the relevant application and have the knowledge of the relevant regulations and standards concerning the application/equipment required for proper installation, or be declared competent by their employer.

The party using Ropeblock products shall be competent and qualified in the operation of the relevant application and have the knowledge of the relevant regulations and standards concerning the application/equipment required for proper operation, or be declared competent by their employer.

Furthermore the party installing and/or using Ropeblock products shall read and fully understand the Warning & Safety information as presented in the back of this catalog. Full responsibility for the safe use and application of Ropeblock products rests with the purchaser and/or user.

Ropeblock is not responsible for any misuse of the products or misinterpretation of this document.

IN CASE OF ANY DOUBT OR PROBLEMS, ALWAYS CONTACT YOUR SALES REPRESENTATIVE OR ROPEBLOCK B.V.

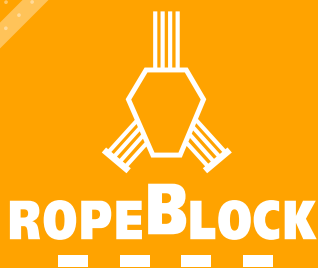

YOU CAN FIND THE WARNING & SAFETY INFORMATION ON PAGES 136 - 149



CONTENTS



04 INTRODUCTION

14 PRODUCTS

136 WARNING AND SAFETY INFORMATION

08 ROPEBLOCK R&D

126 MARKETS



04



12



08



124



136



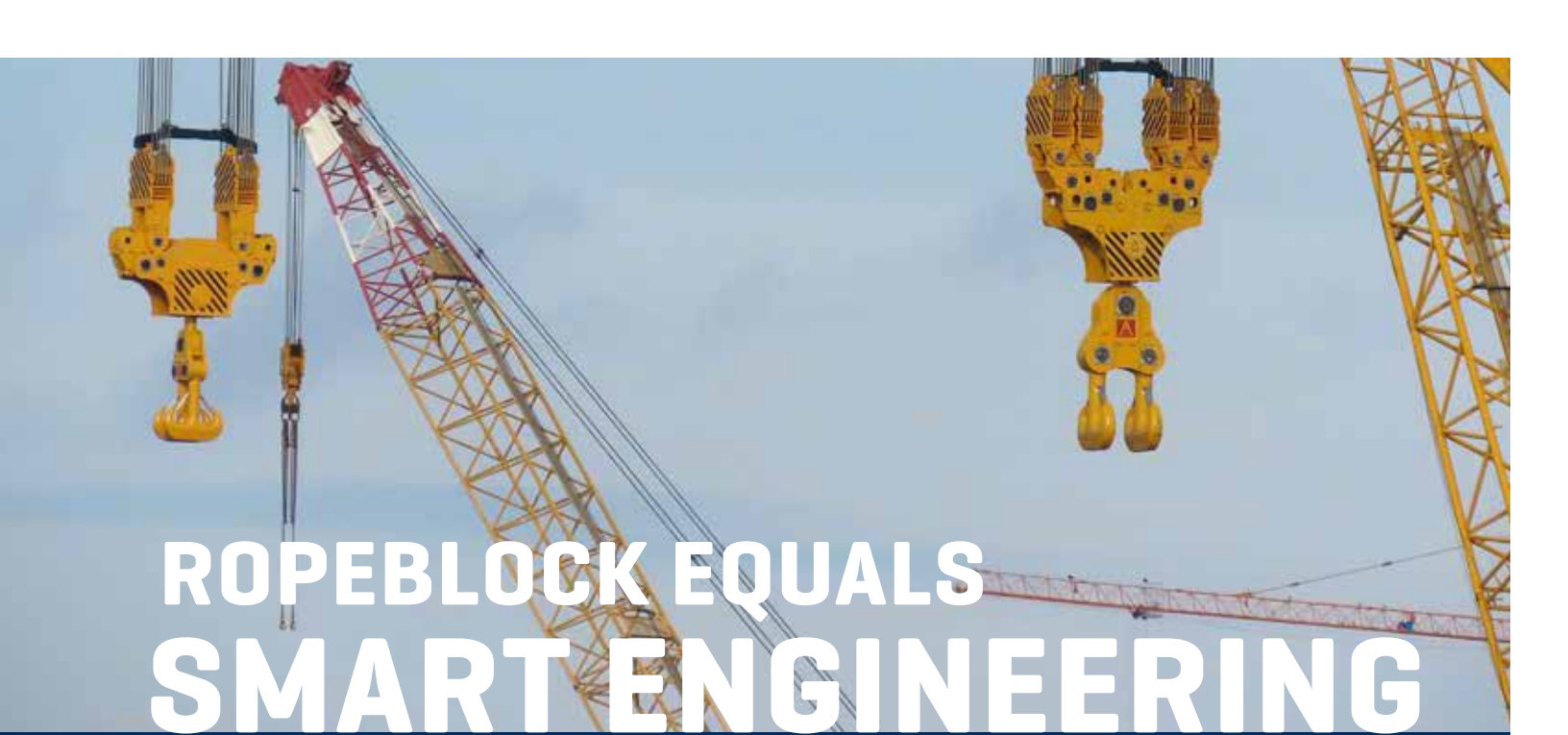

ROPEBLOCK EQUALS SMART ENGINEERING

Established in 1994, Ropeblock is a globally renowned developer and manufacturer of lifting and rigging hardware. We supply safe and high quality components to crane OEMs and end users worldwide. Our products are used in critical equipment such as mobile cranes, port cranes, ship cranes, offshore cranes and platforms, dredging equipment, pendant structures, mooring systems, and heavy industry applications. By providing a reliable interface between the wire rope and its load and efficiently guiding the rope through the crane system, Ropeblock products maximize operational safety as well as wire rope durability.

ENGINEERED FOR EFFICIENCY

Ropeblock products stand out by being engineered for efficiency, which is a matter of matching superior product design and (cost) efficient production. Mind you, our Smart Engineering philosophy goes way beyond actual engineering. It involves the entire process, including quality and safety, certification, and research & development. The fruits of Smart Engineering are often introduced in custom designed solutions. In turn, our standard components benefit as well, as any major innovations and improvements achieved are subsequently incorporated into the entire portfolio of Ropeblock products.

WE KNOW YOUR MARKET

Besides Smart Engineered products and solutions, Ropeblock's excellent reputation is due to thorough knowledge of the markets in which we operate. From construction to cargo handling, offshore to industry, our dedicated specialists know all about industry specific issues, requirements, trends and developments. This very knowledge helps them in

putting customers and customer needs first - which is another Ropeblock trademark. Besides direct sales to customers in our various target markets, Ropeblock products are available from numerous rigging and sling shops worldwide. These vendors are proud to carry Ropeblock catalog products, most of which are instantly available from large stocks.

**IN THIS CATALOG WE WILL TELL YOU ABOUT ROPEBLOCK,
AND INTRODUCE YOU TO OUR PORTFOLIO.**

**IF YOU HAVE ANY QUESTIONS, OUR STAFF WILL BE
GLAD TO BE OF SERVICE**



WHY CHOOSE ROPEBLOCK?

MARKET LEADING DESIGNS

Ropeblock's design philosophy is primarily aimed at supplying low maintenance products that protect the wire rope and extend its lifetime. The implementation of this philosophy is restricted by the rules and regulations of different third parties and governmental institutions.

Our extensive knowledge in this domain has allowed us to come up with truly market leading designs appreciated by OEMs and end-users alike.

THE BENEFITS OF STANDARDIZATION

Wherever possible Ropeblock seeks to standardize its products. As a result, many of them can be used across applications. As an added benefit, lead times are relatively short.

CONSISTENT QUALITY

Consistent product quality is assured by Ropeblock's ISO 9001 QMS and a dedicated team of QA/QC professionals. Our efforts in this regard include elaborate in-house testing, especially where blocks and overhaul balls are concerned. Moreover, our manufacturing process has been approved by DNV, RMRS, BV, RINA and API Q1, with whom we are now in a Manufacturing Survey Arrangement.

FULL COMPLIANCE

Ropeblock products are state of the art designed following European machine directive 2006/42/EC and using relevant guidelines in EN, ISO, DIN or FEM standards, ASME B30.5, B30.10, B30.26 safety standards and e.g. federal specifications RR-S550D, RR-C-271.

Ropeblock products adhere to standards and design rules (such as API 2C, API 8C, ABS, DNV, LRS, BV, GL, RINA, RS, etc.) as mentioned in the contract and/or drawings. With Ropeblock Design For Assembly (DFA) engineering principles they are the perfect choice for local regulations, stipulating hook and hook-nut should be dismantled, inspected and re-tested (proof loaded) every 4 or 5 years.

CERTIFICATES AND DOCUMENTATION

Ropeblock products can be supplied with any certification/ documentation you desire or require, such as declarations of compliance, manufacturer test certificates, material certificates, inspection reports and third party documents.

THE FINISHING TOUCH

An important requirement in the total scope of manufacturing is the finishing, or corrosion protection, of the products. Ropeblock has developed comprehensive finishing methods in accordance with ISO standards, which allows for flexible adaptation to segment specific requirements.

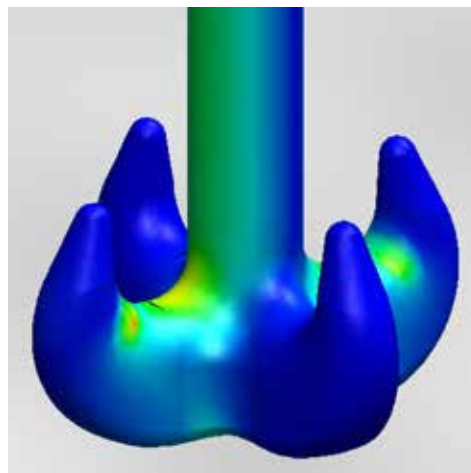



The Ropeblock Quality Management System is certified in accordance with ISO 9001:2015. Our manufacturing processes have been approved by DNV, RMRS, BV, RINA and API Q1, resulting in a Manufacturing Survey Arrangement with these third parties. This, together with a dedicated team of QA/QC professionals, ensures a consistent quality of products and services.

and many more...

QUALITY & CERTIFICATES



STANDARDS AND DESIGN RULES

Ropeblock products are state of the art designed following European machine directive 2006/42/EC and using relevant guidelines in EN, ISO, DIN or FEM standards, ASME B30.5, B30.10, B30.26 safety standards and e.g. federal specifications RR-S550D, RR-C-271. Ropeblock products adhere to standards and design rules (such as API 2C, API 8C, ABS, DNV, LRS, BV, RINA, RS, etc.) as mentioned in the contract and/or drawings.

With Ropeblock Design For Assembly (DFA) engineering principles they are the perfect choice for local regulations, stipulating hook and hook-nut should be dismantled, inspected and re-tested (proof loaded) every 4 or 5 years.

CERTIFICATES AND DOCUMENTS

Upon request, all blocks and swivels can be supplied with any of the following documents:

- Declaration of compliance according to EN 10204 2.1
- Test report according to EN 10204 2.2 (batch proof load test according to ILO 152)
- Inspection certificate finished product according to EN 10204 3.1 (individual product proof load test according to ILO 152)
- Inspection certificate finished product according to EN 10204 3.2, confirmed by a third party (Individual product proof load test according to ILO 152)
- Material certificate according to EN 10204 3.1 for main load bearing part (hook certificate)
- Material certificates according to EN 10204 3.1 for all load bearing parts
- Material certificates confirmed by a third party according to EN 10304 3.2, for main loading part or all load bearing parts
- EC Declaration according to Machine Directive 2006/42/EG where applicable
- NDE inspection reports (e.g. visual, dimensional, magnetic and ultrasonic)
- Witness or survey certificate issued by official classification or inspection agencies, all IACS agencies accepted (e.g. ABS, DNV, LRS)
- Third party design or type approval
- Full manufacturing record book including material certificates, test certificates, welding log, paint log, etcetera.

NOTE THAT THE ABOVE IS AN ABSTRACT OF WHAT IS COMMONLY REQUESTED, BUT NOT CONSIDERED STANDARD. PLEASE ASK YOUR SALES CONTACT FOR DETAILS.



ROPEBLOCK R&D

THE HANDS-ON APPROACH

At Ropeblock, research & development is not an isolated department. Rather, it's an ongoing process that is integral to our Smart Engineering philosophy. Our constant aim is to fulfil customer needs by providing efficient, safe, durable, low-maintenance products and solutions, well thought-out from manufacturing through application. To achieve this, our engineers are always looking for ways to optimize current designs or come up with new ones that do an even better job. Our hands-on approach of R&D has led to success for both our customers and end users, while also yielding patented market leading designs. On these pages we present two examples of highly appreciated product optimizations that couldn't have been achieved without Ropeblock's signature R&D approach.

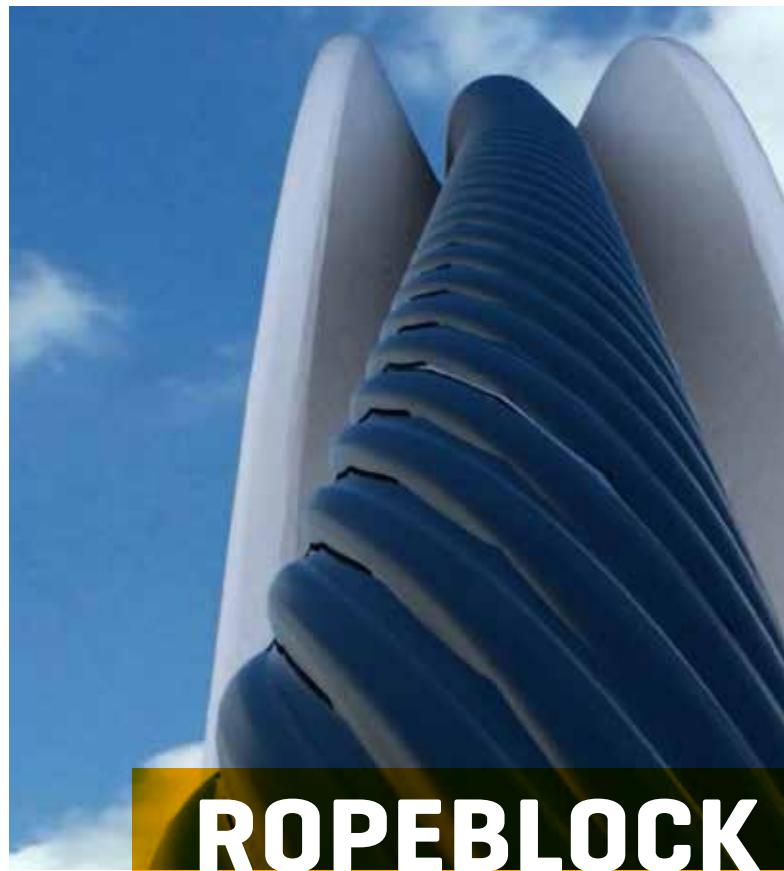

ROPEBLOCK ENGINEERED

In any type of crane system, a wire rope being bent over a sheave will lead to rope fatigue. Recent studies show that this particular type of fatigue is even more severe when the wire rope is in a twisted state. In such cases, the most commonly used rotation resistant ropes may see their longevity reduced by up to 70 percent. At Ropeblock, we took it upon ourselves to address this issue by developing a unique type of sheave.

FLEET ANGLES

One of the major causes of wire rope twist in crane applications is friction between the wire rope and the sheave.

This friction, in turn, is primarily caused by the angle of attack of the wire rope on the sheave groove (a phenomenon also known as fleet angles). Under tension, the end of a wire rope will rotate when free (e.g. with a swivel). However, such rotation

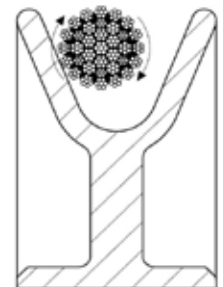

CAST SHEAVES FOR DURABILITY

is not possible when the wire rope is fixed directly to the crane. The additional twist resulting from fleet angles then generates extra torsion. When the accumulated twist in the crane system is released between the tip of the crane and the lower block, block rotation may eventually ensue.

CHOOSING THE OPTIMUM MATERIAL

The degree of friction in crane systems largely depends on the type of sheave used. Plastic sheaves, especially, are known to cause above-average friction, hence, more twist. Consequently, after meticulous R&D, Ropeblock introduced a unique type of cast sheave. It ensures optimum interaction with the wire rope, resulting in significant friction reduction and record amounts of Cycle Bends Over Sheave (CBOS) in any application.

GRAPHITE LUBRICATION

The secret of the Ropeblock cast sheave is dry graphite lubrication, which works in a way similar to bronze bearings with graphite nodes. By making the wire rope slide rather than twisting it, Ropeblock sheaves substantially lower the friction coefficient. Once the rope and groove are properly run in, wear is reduced

to practically zero. What's more, improved sheave ductility provides better resistance against impact or unintended blows against objects, while the material grain makes sheaves more crack-resistant. As an added benefit when operating in extreme circumstances, Ropeblock graphite sheaves have a better than average low temperature performance, allowing service down to even $-40^{\circ}\text{C}/-40^{\circ}\text{F}$.

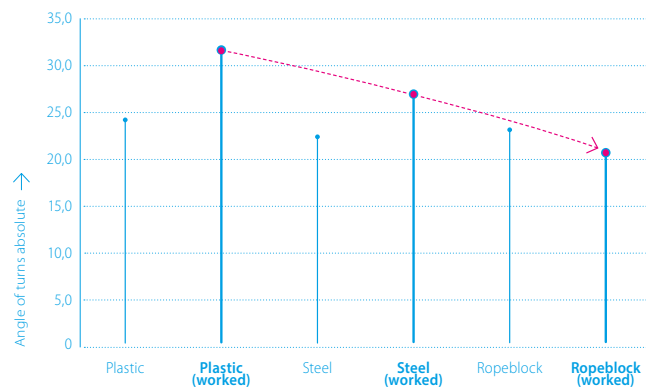

LONGER LASTING

Research in a lab environment proved that by minimizing wire rope twist Ropeblock sheaves make wire rope last up to 40 percent longer when compared to the same size and geometry plastic sheaves. When compared to regular steel sheaves of the same size and geometry, Ropeblock sheaves perform better by 25 percent. All in all, Ropeblock sheaves make crane systems safer, improve uptime and optimize cost effectiveness. They come in hundreds of different bearing and D/d sizes, ranging from wire rope 10 mm to 76 mm and beyond, and are accepted by all major classification societies.





ROPEBLOCK OPTIMIZED RAMSHORN HOOKS ENGINEERED FOR EFFICIENCY



Crane blocks and lifting hooks are often used in applications that include soft eye and steel wire rope slings and grommets.

The capacity of these slings and grommets largely depends on the bending radius on the hook saddle. The sharper the edge, the lower the capacity. Oversized slings/grommets need to be selected to meet the required load and wear will arise on the bending spots.

INCREASED BENDING RADIUS

To remedy this, Ropeblock developed a new generation of ramshorn hooks featuring a significantly larger bending radius in the sling zone. The increased bending radius improves the working efficiency of slings and grommets. The resulting wear reduction translates into improved endurance, while capacity is less compromised.

WIRE ROPE BENDING RADIUS

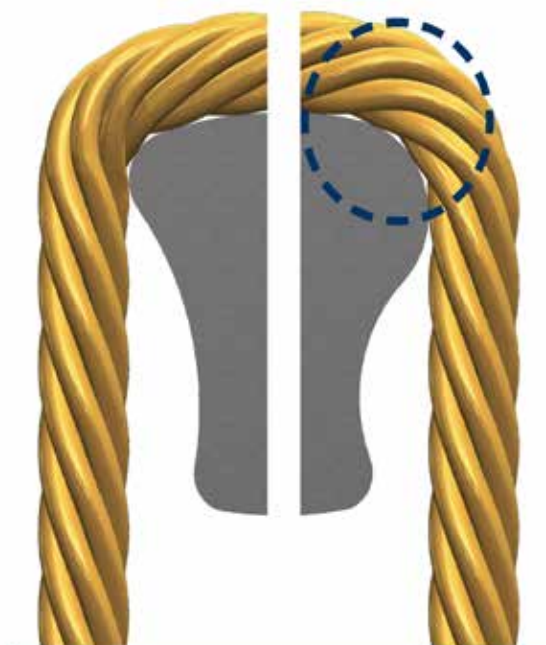

STANDARD SHAPE

ROPEBLOCK OPTIMIZED SHAPE

EN AND DIN COMPLIANT

Whereas the new geometry makes the hook body exceed EN and DIN standards (including EN13001-3-5), the shape still allows the hooks to work with traditional hardware. All in all this is the safe choice for any application. The new improved ramshorn hooks are available in the medium and larger capacity range (sizes 16 and up) where grommets and soft-eye slings are used along with traditional hardware.

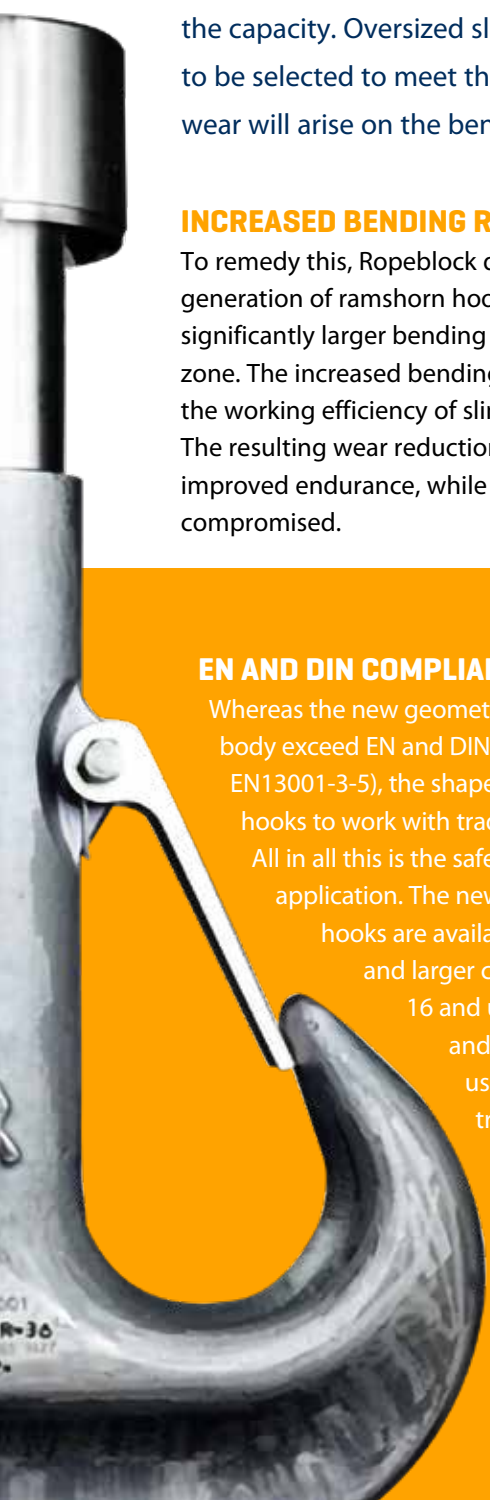
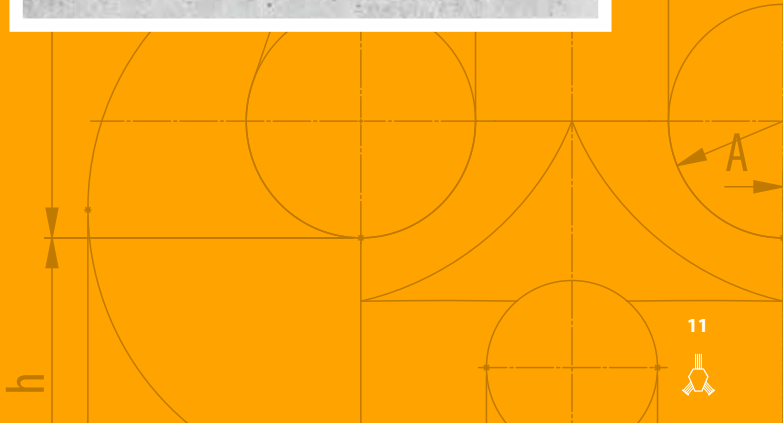

PRODUCT OVERVIEW



CRANE BLOCKS & OVERHAUL BALLS

The Ropeblock portfolio includes a wide range of crane blocks with proven quality assured by a track record spanning 25 years.

PAGE 15

MISCELLANEOUS BLOCKS

Ropeblock offers a wide choice of standard blocks. Some were developed for general purposes, others for specific rigging equipment. Possible applications include routing or guiding wire rope, upending and wall tilt-up, and cargo handling on merchant vessels.

PAGE 42

SHEAVES

The Ropeblock range of highly efficient, Smart Engineered standard sheaves is extensive. It includes API sheaves, cast sheaves, plastic sheaves, welded sheaves, sheaves from solid materials and forged sheaves.

PAGE 64





SOCKETS

Ropeblock provides sockets for both general purpose and high performance ropes. These sockets are used in extreme environments. Besides the standard sockets shown in this catalog we can Smart Engineer any required special socket solution.

PAGE 82

TURNBUCKLES

Turnbuckles may be supplied in endless variations, in workload, in size, in take up, in locking, in connections, in type of thread.

PAGE 108

COMPONENTS

The Ropeblock portfolio includes a wide choice of proven quality components for various lifting & rigging purposes, such as split overhaul balls, triangle plates and pad eyes.

PAGE 116



ROPEBLOCK

PRODUCTS





CRANE BLOCKS & OVERHAUL BALLS

The Ropeblock portfolio includes a wide range of crane blocks with proven quality assured by a track record spanning 25 years. They feature superb finishing and a high degree of flexibility in terms of, e.g., possible weights and wire rope diameters, and hook interchangeability.

- Components include Ropeblock cast sheaves with maintenance free bearings.
- Axial cylindrical roller bearings minimise rotational resistance of the hook.
- Spare parts are readily available from stock.

RECOMMENDED FINISH

Segment / application	ISO 12944 classification	Classification description	Expected protection duration	DFT (µm)
Construction	C2M	Slightly polluted atmosphere, predominately agriculture areas	5 to 15 year	120
Construction	C3M	Industrial and residential air pollution levels, with an average sulfurdioxide (IV) contamination level. Coastal areas with low salt content in air	2 to 5 year	120
Construction	C3M	Industrial and residential air pollution levels, with an average sulfurdioxide (IV) contamination level. Coastal areas with low salt content in air	5 to 15 year	160
Cargo handling	C3M	Industrial and residential air pollution levels, with an average sulfurdioxide (IV) contamination level. Coastal areas with low salt content in air	5 to 15 year	160
Cargo handling	C4H	Industrial areas and coastal areas with average salt content in air	more than 15 year	280
Cargo handling	C5-MM	Coastal areas and open sea with high salt content in air	5 to 15 year	280
Offshore	C4H	Industrial areas and coastal areas with average salt content in air	more than 15 year	300
Offshore	C5-MM	Coastal areas and open sea with high salt content in air	5 to 15 year	300
Offshore	C5-MH	Coastal areas and open sea with high salt content in air	more than 15 year	320
Offshore	NORSOK sys. 1*	Open sea with high salt content in air	more than 15 year	300



CONSTRUCTION SPECIFIC BLOCKS

FAST REEVE CRANE BLOCKS

Ropeblock Fast Reeve Crane Blocks are suitable for use on a wide variety of mobile cranes, crawler cranes and other land-based cranes. These blocks are an excellent choice for lifting applications requiring frequent block change.

Standard features include:

- Design factor: 4:1
- Double-sealed maintenance-free roller bearings
- Forged high tensile steel EN/DIN hooks
- Cast sheaves featuring graphite lubricated groove
- Robust design
- Operational temperature range: -40 up to +80°C / -40 up to +176°F
- Lubrication on hook suspension
- 4 or 8 point hook locking device
- Fast reeve guides for fast reeving
- C3M finish in signal yellow with black striping
- Safety latch with locking pin

PLEASE CONTACT US FOR MORE DETAILS

THE ANATOMY OF A ROPEBLOCK CRANE BLOCK PRODUCT NUMBER

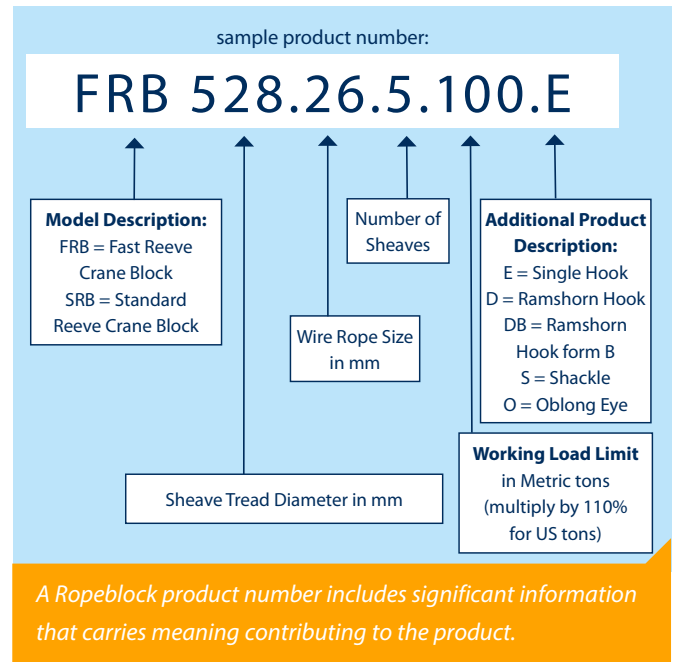

FAST REEVE CRANE BLOCKS >>

1 SHEAVE

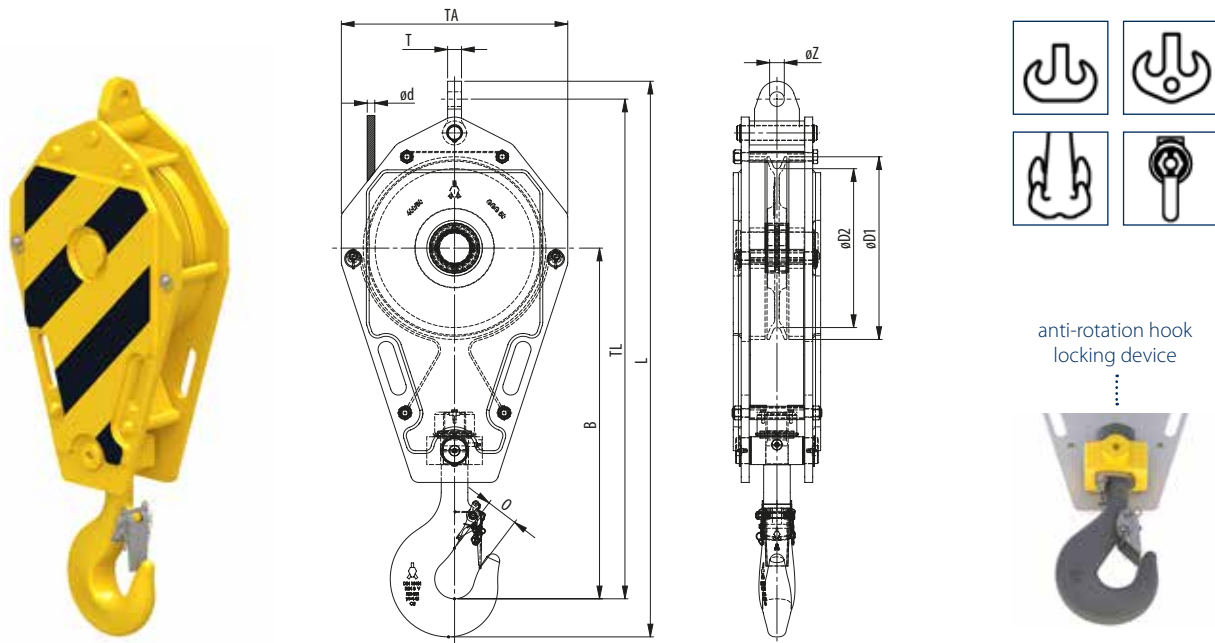

Model No.	WLL (UStons)	For wire ød (inch)	Hook size	Dimensions (inch)									Weight (lbs)
				øD1	øD2	B	O	TA	TL	L	T	øZ	
FRB 225.xx.1.12.5.E	13.7	3/8 - 9/16	4	10.2	8.9	23.1	2.2	13.6	34	38.2	TBD	TBD	195
FRB 260.xx.1.12.5.E	13.7	7/16 - 5/8	4	11.8	10.2	25.7	2.2	15.7	36.9	41.9	TBD	TBD	220
FRB 225.xx.1.16.E	17.6	3/8 - 9/16	6	10.2	8.9	23.9	2.8	13.6	34.8	39.7	TBD	TBD	225
FRB 260.xx.1.16.E	17.6	7/16 - 5/8	6	11.8	10.2	27.3	2.8	15.7	38.5	43.4	TBD	TBD	265 325 375
FRB 285.xx.1.16.E	17.6	1/2 - 3/4	6	12.6	11.2	28.5	2.8	16.5	40.3	45.2	TBD	TBD	350
FRB 320.xx.1.16.E	17.6	9/16 - 3/4	6	14.4	12.6	28.7	2.8	17.7	41.8	46.8	TBD	TBD	350 425 475
FRB 355.xx.1.16.E	17.6	9/16 - 7/8	6	16.1	14	31	2.8	19.7	44.6	49.7	TBD	TBD	500 550
FRB 260.xx.18,2.E	20	7/16 - 5/8	5	11.8	10.2	23.3	2.2	14.4	32.1	36.7	TBD	TBD	409
FRB 225.xx.1.20.E	22	3/8 - 9/16	8	10.2	8.9	28.2	3.1	19.6	37.7	43.1	TBD	TBD	250
FRB 260.xx.1.20.E	22	7/16 - 5/8	8	11.8	10.2	29.4	3.1	15.7	40.7	46	TBD	TBD	285 375 425
FRB 285.xx.1.20.E	22	1/2 - 3/4	8	12.6	11.2	30.6	3.1	16.5	42.4	47.8	TBD	TBD	350
FRB 320.xx.1.20.E	22	9/16 - 3/4	8	14.4	12.6	30.2	3.1	17.7	43.3	48.7	TBD	TBD	350 425 475
FRB 355.xx.1.20.E	22	9/16 - 7/8	8	16.1	14	33.6	3.1	19.7	47.2	52.5	TBD	TBD	550 660
FRB 355.xx.1.25.E	27.5	9/16 - 7/8	8	16.1	14	33.4	3.1	19.7	47	52.5	TBD	TBD	550 750
FRB 400.xx.1.25.E	27.5	5/8 - 1	8	18.1	15.7	34.8	3.1	22.4	49.5	55.2	TBD	TBD	700 750
FRB 400.xx.1.26.E	28.5	5/8 - 1	8	18.1	15.7	34.8	3.1	22.4	49.5	55.2	TBD	TBD	1100
FRB 400.xx.1.29.E	32	5/8 - 1	8	18.1	15.7	34.8	3.1	22.4	49.9	55.6	TBD	TBD	800
FRB 450.xx.1.29.E	32	3/4 - 1 1/8	8	20.3	17.7	37.3	3.1	23.6	51.4	59.3	TBD	TBD	650 800
FRB 450.xx.1.32.E	35	3/4 - 1 1/8	10	20.3	17.7	39.5	3.5	23.6	56.1	62.7	TBD	TBD	1000 1100 1320
FRB 528.xx.1.32.E	35	7/8 - 1 1/4	10	23.4	20.8	40.5	3.5	28	58.7	65.3	TBD	TBD	1100 1320 1500 1800
FRB 670.xx.1.32.E	35	1 - 1 1/2	10	29.9	26.4	41.3	3.5	34.3	63.3	70.3	TBD	TBD	1700
FRB 450.xx.1.37.E	40	3/4 - 1 1/8	10	20.3	17.7	39.5	3.5	23.6	55.8	61.9	TBD	TBD	1455
FRB 528.xx.1.37.E	40	7/8 - 1 1/4	10	23.4	20.8	40.7	3.5	27.9	58.5	64.7	TBD	TBD	2270 3080

Minimum Ultimate Strength = 4 x WLL

xx = to be replaced by metric wire size in final part number; TBD = these dimensions vary with wire size;
 * blocks can be fitted with removable / interchangeable cheek weights

- The dimensions in this table are indicative only. A drawing will always be submitted prior to production and will be the leading document when discussing dimensions.
- Blocks shown here are standard models; inquiries for custom versions are welcome.
- Refer to wire rope manufacturers D/d ratio guideline.
- Hook locking pin included on all blocks 45UStons and higher.



SEE OUR WARNING & SAFETY INFORMATION ON PAGES 136 - 149



<< FAST REEVE CRANE BLOCKS

1 SHEAVE

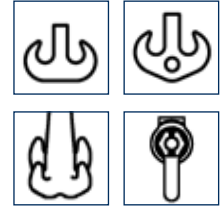
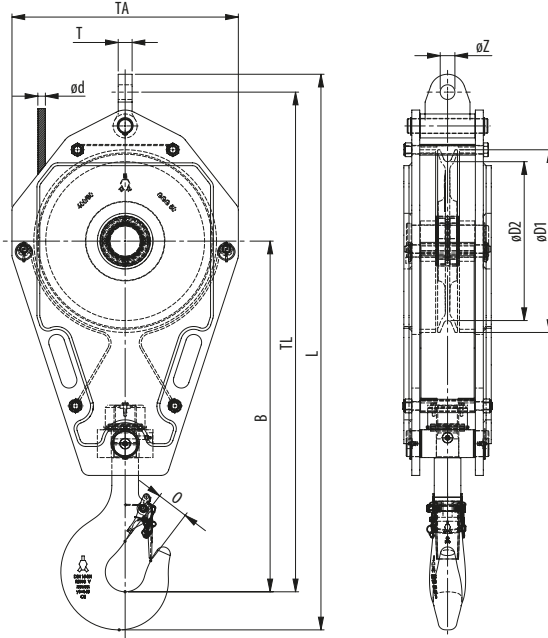

anti-rotation hook locking device



Model No.	WLL (UStons)	For wire ød (inch)	Hook size	Dimensions (inch)									Weight (lbs)
				øD1	øD2	B	O	TA	TL	L	T	øZ	
FRB 450.xx.1.40.E	45	¾ - 1⅛	12	20.3	17.7	42.3	3.9	23.6	58.9	65.9	TBD	TBD	1300 1500
FRB 528.xx.1.40.E	45	⅞ - 1¼	12	23.4	20.8	43.9	3.9	28	62.7	69.7	TBD	TBD	1500 1700 1875 2000
FRB 450.xx.1.50.E	55	¾ - 1⅛	12	20.3	17.7	43.1	3.9	23.6	59.6	67.2	TBD	TBD	1300 1500
FRB 528.xx.1.50.E	55	⅞ - 1¼	12	23.4	20.8	43.7	3.9	28	62.6	70.1	TBD	TBD	1500 1700 1875 2000
FRB 575.xx.1.50.E	55	1⅝ - 1¾	12	25.6	22.6	45	3.9	30.3	64.9	72.9	TBD	TBD	2200
FRB 630.xx.1.50.E	55	1 - 1⅜	12	27.9	24.8	43.6	3.9	35.4	64.7	72.1	TBD	TBD	1800 3500 5300*
FRB 670.xx.1.50.E	55	1 - 1½	12	29.9	26.4	44.1	3.9	34.3	66.3	73.7	TBD	TBD	2000 2600 3000
FRB 670.xx.1.64.E	70	1 - 1½	16	29.9	26.4	49.1	4.4	34.3	71.4	79.3	TBD	TBD	2200 2600 3000

Minimum Ultimate Strength = 4 x WLL

xx = to be replaced by metric wire size in final part number; TBD = these dimensions vary with wire size;
 * blocks can be fitted with removable / interchangeable cheek weights

- The dimensions in this table are indicative only. A drawing will always be submitted prior to production and will be the leading document when discussing dimensions.
- Blocks shown here are standard models; inquiries for custom versions are welcome.
- Refer to wire rope manufacturers D/d ratio guideline.
- Hook locking pin included on all blocks 45UStons and higher.



SEE OUR WARNING & SAFETY INFORMATION ON PAGES 136 - 149



FAST REEVE CRANE BLOCKS

2 SHEAVES

CRANE BLOCKS

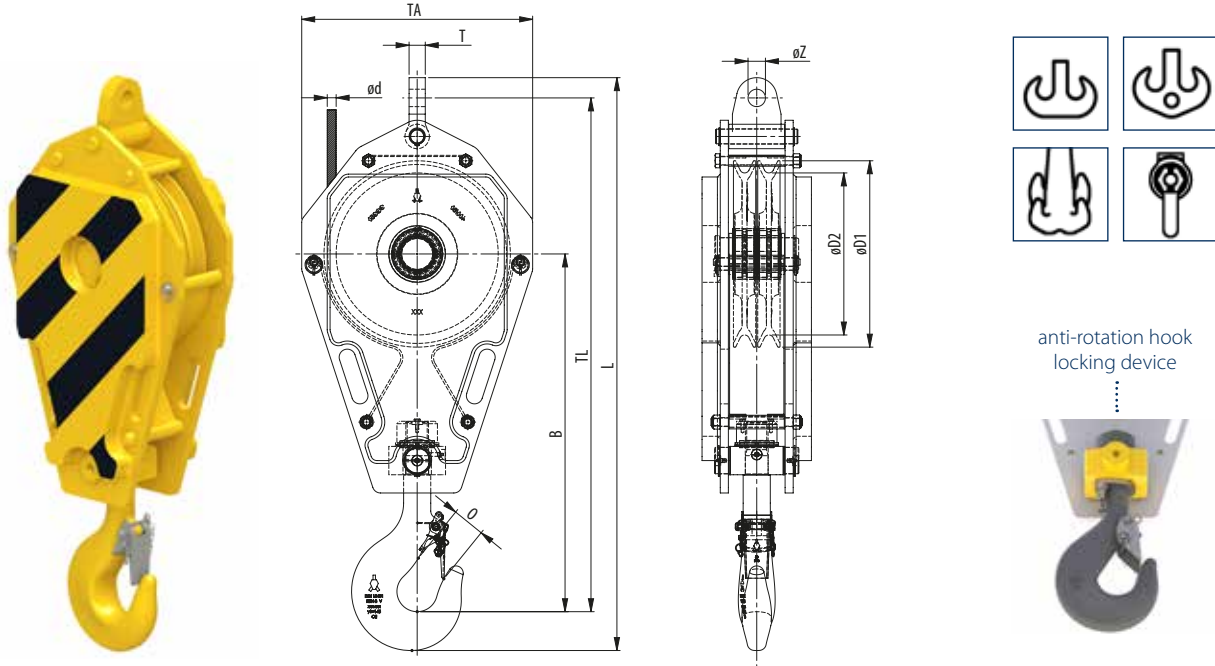

Model No.	WLL (UStons)	For wire ød (inch)	Hook size	Dimensions (inch)									Weight (lbs)
				øD1	øD2	B	O	TA	TL	L	T	øZ	
FRB 225.xx.2.16.E	17.6	3/8 - 9/16	6	10.2	8.9	23.9	2.8	13.6	34.8	39.7	TBD	TBD	265
FRB 260.xx.2.16.E	17.6	7/16 - 5/8	6	11.8	10.2	27.3	2.8	15.7	38.5	43.4	TBD	TBD	285 350
FRB 225.xx.2.20.E	22	3/8 - 9/16	8	10.2	8.9	28.3	3.1	13.6	37.7	43.1	TBD	TBD	285
FRB 260.xx.2.20.E	22	7/16 - 5/8	8	11.8	10.2	29.4	3.1	15.7	40.7	46	TBD	TBD	285 350 425
FRB 260.xx.2.25.E	27.5	7/16 - 5/8	8	11.8	10.2	29.3	3.1	15.7	40.5	45.6	TBD	TBD	350 425
FRB 320.xx.2.25.E	27.5	1/2 - 3/4	8	14.4	12.6	30	3.1	17.7	43.1	48.5	TBD	TBD	450 495
FRB 320.xx.2.29.E	32	1/2 - 3/4	8	14.4	12.6	30.1	3.1	17.3	43.1	48.5	TBD	TBD	600
FRB 355.xx.2.29.E	32	1/2 - 7/8	8	16.1	14	33.4	3.1	19.7	47	52.5	TBD	TBD	585 625 750
FRB 400.xx.2.32.E	35	5/8 - 1	10	18.1	15.7	37.5	3.5	22.4	52.7	58.9	TBD	TBD	800
FRB 450.xx.2.32.E	35	3/4 - 1 1/8	10	20.3	17.7	39.5	3.5	23.6	55.7	61.9	TBD	TBD	1100
FRB 450.xx.2.46.E	50	3/4 - 1 1/8	12	20.3	17.7	42.2	3.9	23.6	58.5	65.2	TBD	TBD	1200 1500
FRB 450.xx.2.55.E	60	3/4 - 1 1/8	16	20.3	17.7	42.3	4.4	23.6	58.9	66.5	TBD	TBD	1600
FRB 528.xx.2.55.E	60	7/8 - 1 1/4	12	23.4	20.8	43.8	3.9	27.9	62.6	70.1	TBD	TBD	2000
FRB 670.xx.2.55.E	60	1 - 1 1/2	12	29.9	26.4	44.2	3.9	34.3	67	74.1	TBD	TBD	2080
FRB 528.xx.2.70.E	77	7/8 - 1 1/4	16	23.4	20.8	47.3	4.4	28	65.2	72.8	TBD	TBD	2200
FRB 670.xx.2.82.E	90	1 - 1 1/2	20	29.9	26.4	50.7	4.9	34.3	74.7	83.6	TBD	TBD	3400

Minimum Ultimate Strength = 4 x WLL

xx = to be replaced by metric wire size in final part number; TBD = these dimensions vary with wire size;
 * blocks can be fitted with removable / interchangeable cheek weights

- The dimensions in this table are indicative only. A drawing will always be submitted prior to production and will be the leading document when discussing dimensions.
- Blocks shown here are standard models; inquiries for custom versions are welcome.
- Refer to wire rope manufacturers D/d ratio guideline.
- Hook locking pin included on all blocks 45UStons and higher.



SEE OUR WARNING & SAFETY INFORMATION ON PAGES 136 - 149

SEE OUR WARNING AND SAFETY INFORMATION ON PAGE 136

FAST REEVE CRANE BLOCKS >>

3 SHEAVES

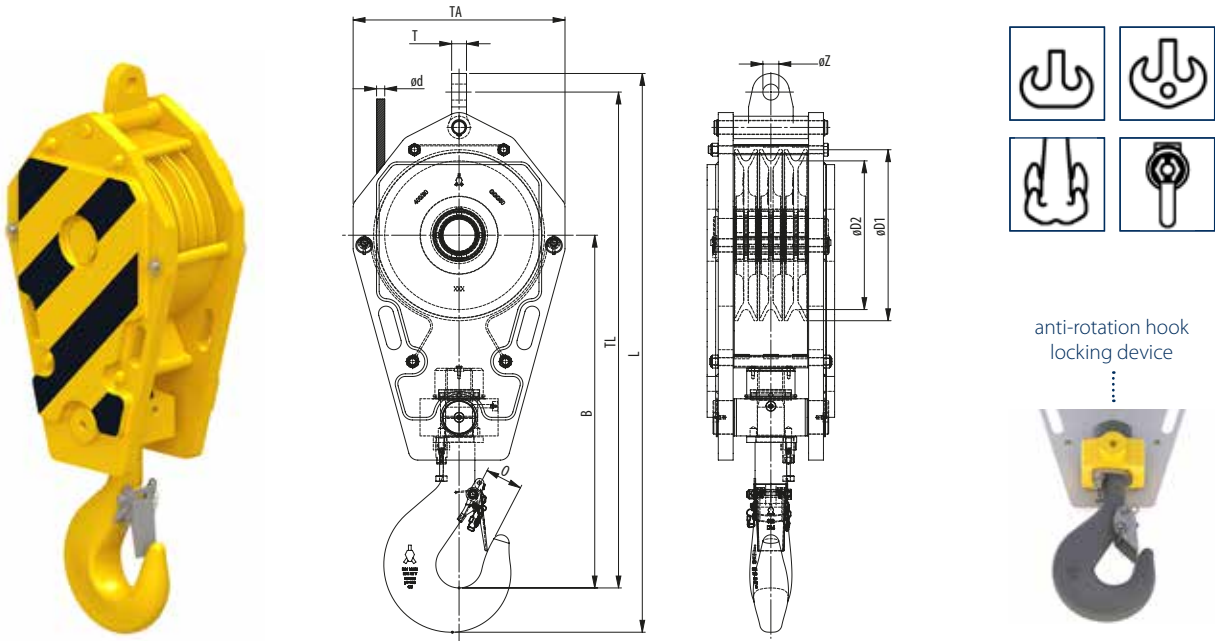

Model No.	WLL (USTons)	For wire ød (inch)	Hook size	Dimensions (inch)									Weight (lbs)
				øD1	øD2	B	O	TA	TL	L	T	øZ	
FRB 225.xx.3.20.E	22	3/8 - 1/16	8	10.2	8.9	28.3	3.1	13.6	39.1	44.4	TBD	TBD	410
FRB 260.xx.3.20.E	22	7/16 - 5/8	8	11.8	10.2	28.5	3.1	15.7	40.1	45.4	TBD	TBD	410
FRB 260.xx.3.25.E	27.5	7/16 - 5/8	8	11.8	10.2	27.5	3.1	15.7	39.1	44.4	TBD	TBD	465
FRB 285.xx.3.29.E	32	1/2 - 3/4	8	12.6	11	27.7	3.5	16.5	39.9	45.2	TBD	TBD	460
FRB 320.xx.3.29.E	32	9/16 - 3/4	8	14.4	12.6	30	3.1	17.7	43.1	48.5	TBD	TBD	505
FRB 260.xx.3.32.E	35	7/16 - 5/8	10	11.8	10.2	28.9	3.5	15.7	40.5	46.3	TBD	TBD	465 585
FRB 285.xx.3.32.E	35	1/2 - 3/4	10	12.6	11	30	3.5	16.5	42.2	48	TBD	TBD	460 505
FRB 320.xx.3.32.E	35	9/16 - 3/4	10	14.4	12.6	32.2	3.5	17.7	45.3	51.1	TBD	TBD	505 625
FRB 320.xx.3.37.E	40	9/16 - 3/4	10	14.4	12.6	32.2	3.5	17.7	45.3	51.1	TBD	TBD	600 700
FRB 355.xx.3.37.E	40	9/16 - 7/8	10	16.1	14	34	3.5	19.7	48	53.7	TBD	TBD	700 825
FRB 360.xx.3.41.E	45	5/8 - 7/8	12	16.5	14.2	35.4	3.9	20.1	49.3	55.8	TBD	TBD	900
FRB 360.xx.3.46.E	50	5/8 - 7/8	12	16.5	14.2	35.4	3.9	20.1	49.3	55.8	TBD	TBD	900
FRB 400.xx.3.46.E	50	5/8 - 1	12	18.1	15.7	37.3	3.9	22.4	52.1	58.6	TBD	TBD	1000
FRB 360.xx.3.50.E	55	5/8 - 7/8	12	16.5	14.2	35.4	3.9	20.1	49.4	56.3	TBD	TBD	900 1200
FRB 400.xx.3.50.E	55	5/8 - 1	12	18.1	15.7	37.4	3.9	22.4	52.1	59.1	TBD	TBD	1100 1200 1350
FRB 360.xx.3.55.E	60	5/8 - 7/8	12	16.5	14.2	35.4	3.9	20.1	49.3	55.8	TBD	TBD	900 1200
FRB 400.xx.3.55.E	60	5/8 - 1	12	18.1	15.7	37.4	3.9	22.4	52.1	59.1	TBD	TBD	1100 1200 1350

Minimum Ultimate Strength = 4 x WLL

xx = to be replaced by metric wire size in final part number; TBD = these dimensions vary with wire size;

* blocks can be fitted with removable / interchangeable cheek weights

- The dimensions in this table are indicative only. A drawing will always be submitted prior to production and will be the leading document when discussing dimensions.
- Blocks shown here are standard models; inquiries for custom versions are welcome.
- Refer to wire rope manufacturers D/d ratio guideline.
- Hook locking pin included on all blocks 45USTons and higher.



SEE OUR WARNING & SAFETY INFORMATION ON PAGES 136 - 149



<< FAST REEVE CRANE BLOCKS

3 SHEAVES

CRANE BLOCKS

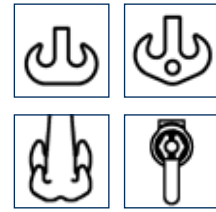
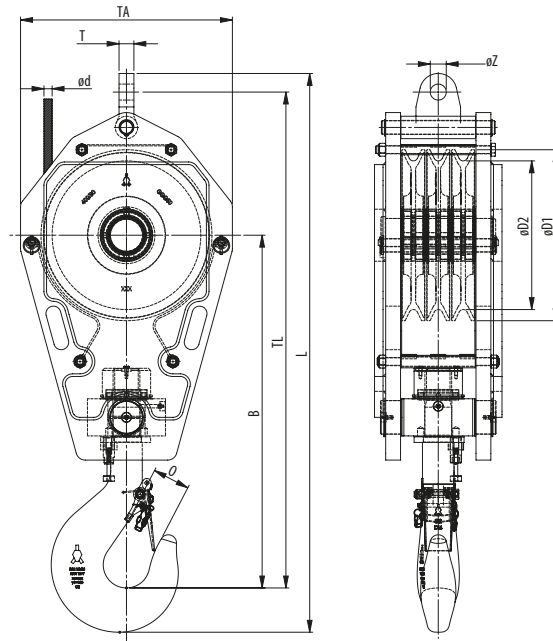

anti-rotation hook locking device



Model No.	WLL (USTons)	For wire ød (inch)	Hook size	Dimensions (inch)									Weight (lbs)
				øD1	øD2	B	O	TA	TL	L	T	øZ	
FRB 528.xx.3.55.E	60	7/8 - 1¼	12	23.4	20.8	43.8	3.9	27.9	62.1	69.1	TBD	TBD	2300
FRB 400.xx.3.63.E	69	5/8 - 1	16	18.1	15.7	37.4	4.4	22.4	52.1	59.1	TBD	TBD	1350 2000 2100
FRB 400.xx.3.64.E	70	5/8 - 1	16	18.1	15.7	37.4	4.4	22.4	52.1	59.1	TBD	TBD	1600
FRB 450.xx.3.64.E	70	¾ - 1½	16	20.3	17.7	40.9	4.4	23.6	57.2	64.8	TBD	TBD	1500 1700
FRB 450.xx.3.70.E	77	¾ - 1½	16	20.3	17.7	41.1	4.4	23.6	57.4	64.6	TBD	TBD	1500 1700 1800
FRB 528.xx.3.70.E	77	7/8 - 1¼	16	23.4	20.8	47.6	4.4	28	65.9	73.5	TBD	TBD	2350
FRB 450.xx.3.82.E	90	¾ - 1½	20	20.3	17.7	46.5	4.9	23.6	62.8	70.7	TBD	TBD	1800 2200
FRB 528.xx.3.82.E	90	7/8 - 1¼	20	23.4	20.8	50.1	4.9	28	68.3	76.6	TBD	TBD	2500 2800
FRB 630.xx.3.82.E	90	1 - 1¾	20	27.9	24.8	53.7	4.9	32.7	74.1	82.1	TBD	TBD	3600
FRB 528.xx.3.100.E	110	7/8 - 1¼	20	23.4	20.8	50.1	4.9	28	68.3	76.6	TBD	TBD	2500 2800
FRB 528.xx.3.100.E	110	7/8 - 1¼	25	23.4	20.8	53.7	5.5	28	71.9	80.9	TBD	TBD	2860 3000
FRB 575.xx.3.100.E	110	1½/16 - 1¼	25	25.6	22.6	51.3	5.5	30.3	71.2	80.6	TBD	TBD	3000
FRB 575.xx.3.100.E	110	1½/16 - 1¼	25	25.6	22.6	51.3	5.5	30.3	71.2	80.6	TBD	TBD	2425 4520 6620*
FRB 630.xx.3.100.E	110	1 - 1¾	25	27.9	24.8	53.3	5.5	32.7	74.4	83.9	TBD	TBD	2425 4520 6620*
FRB 630.xx.3.100.E	110	1 - 1¾	25	27.9	24.8	53.3	5.5	32.7	74.4	83.9	TBD	TBD	3500 5950
FRB 670.xx.3.100.E	110	1 - 1½	25	29.9	26.4	55.2	5.5	34.3	77.5	87	TBD	TBD	4000 14000*
FRB 630.xx.3.125.E	137,5	1 - 1¾	25	27.9	24.8	55.4	5.5	35.4	77.7	88	TBD	TBD	3300 12100*
FRB 670.xx.3.137.E	150	1 - 1½	25	29.9	26.4	54.6	5.5	34.3	73.8	83.2	TBD	TBD	8100 16000*

Minimum Ultimate Strength = 4 x WLL

xx = to be replaced by metric wire size in final part number; TBD = these dimensions vary with wire size;

* blocks can be fitted with removable / interchangeable cheek weights

- The dimensions in this table are indicative only. A drawing will always be submitted prior to production and will be the leading document when discussing dimensions.
- Blocks shown here are standard models; inquiries for custom versions are welcome.
- Refer to wire rope manufacturers D/d ratio guideline.
- Hook locking pin included on all blocks 45USTons and higher.



SEE OUR WARNING & SAFETY INFORMATION ON PAGES 136 - 149

SEE OUR WARNING AND SAFETY INFORMATION ON PAGE 136



FAST REEVE CRANE BLOCKS

4 SHEAVES

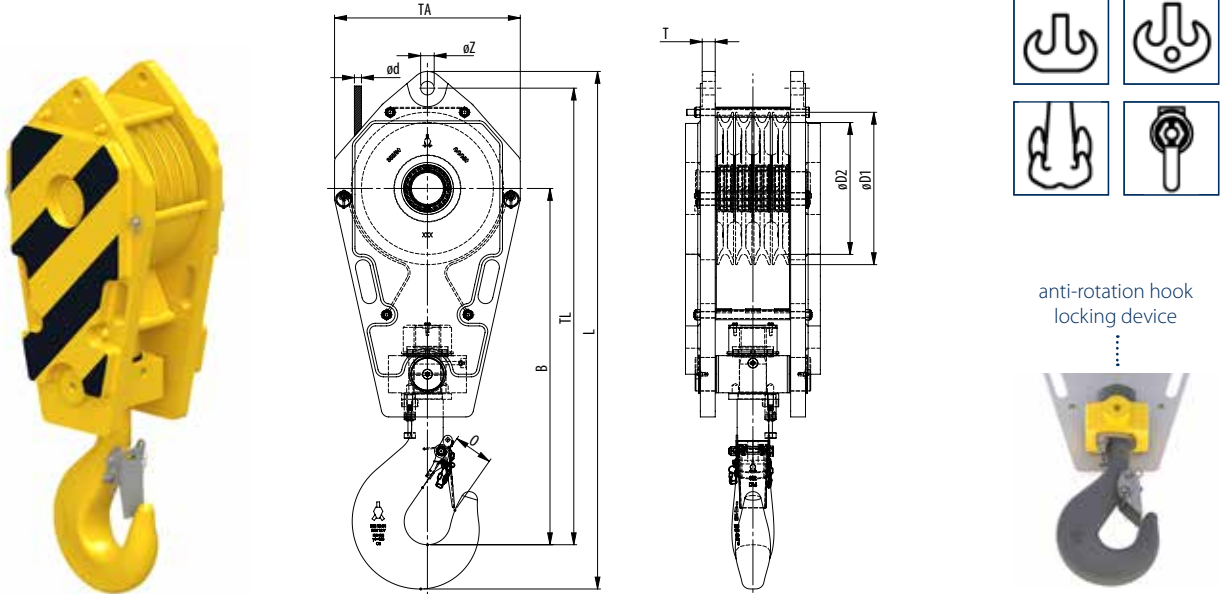

Model No.	WLL (UStons)	For wire ød (inch)	Hook size	Dimensions (inch)									Weight (lbs)
				øD1	øD2	B	O	TA	TL	L	T	øZ	
FRB 355.xx.4.35.E	38.5	5/16 - 7/8	10	16.1	14	36.7	3.5	19.7	47.4	53.1	TBD	TBD	925
FRB 320.xx.4.37.E	40	5/16 - 3/4	10	14.4	12.6	29.6	3.5	17.7	39	44.8	TBD	TBD	700
FRB 355.xx.4.37.E	40	5/16 - 7/8	10	16.1	14	34	3.5	19.7	44.6	50.4	TBD	TBD	620
FRB 320.xx.4.41.E	45	5/16 - 3/4	12	14.4	12.6	34.6	3.9	17.7	43.9	50.2	TBD	TBD	760
FRB 355.xx.4.46.E	50	5/16 - 7/8	12	16.1	14	37.7	3.9	19.7	48.1	54.2	TBD	TBD	1000
FRB 355.xx.4.55.E	60	5/16 - 7/8	12	16.1	14	37.8	3.9	19.7	48.4	54.8	TBD	TBD	1100 1280
FRB 400.xx.4.70.E	77	5/8 - 1	16	18.1	15.7	40.9	4.4	22.4	52.5	57.7	TBD	TBD	1500
FRB 450.xx.4.70.E	77	3/4 - 1 1/8	16	20.3	17.7	40.9	4.4	23.6	57	62.2	TBD	TBD	1650 1800 1950 2400
FRB 528.xx.4.70.E	77	7/8 - 1 1/4	16	23.4	20.8	42.7	4.4	27.9	57.7	65.1	TBD	TBD	2800
FRB 528.xx.4.82.E	90	7/8 - 1 1/4	20	23.4	20.8	50.1	4.9	28	68.3	74.3	TBD	TBD	2800 2950
FRB 528.xx.4.100.E	110	7/8 - 1 1/4	25	23.4	20.8	50.7	5.5	28	68.6	75.3	TBD	TBD	2800 2950
FRB 528.xx.4.105.E	115	7/8 - 1 1/4	25	23.4	20.8	52.1	5.5	28	67.6	77.1	TBD	TBD	3850
FRB 528.xx.4.137,5.E	150	7/8 - 1 1/4	32	23.4	20.8	54.6	6.3	28	69.8	79.9	TBD	TBD	3150
FRB 575.xx.4.137,5.E	150	1 1/16 - 1 1/4	32	25.6	22.6	55.6	6.3	30.3	72.2	82.1	TBD	TBD	3000
FRB 670.xx.4.137,5.E	150	1 - 1 1/2	32	29.9	26.4	56.7	6.3	34.3	75.7	86	TBD	TBD	3200

Minimum Ultimate Strength = 4 x WLL

xx = to be replaced by metric wire size in final part number; TBD = these dimensions vary with wire size;
 * blocks can be fitted with removable / interchangeable cheek weights

- The dimensions in this table are indicative only. A drawing will always be submitted prior to production and will be the leading document when discussing dimensions.
- Blocks shown here are standard models; inquiries for custom versions are welcome.
- Refer to wire rope manufacturers D/d ratio guideline.
- Hook locking pin included on all blocks 45UStons and higher.

SEE OUR WARNING & SAFETY INFORMATION ON PAGES 136 - 149



FAST REEVE CRANE BLOCKS >>

5 SHEAVES

CRANE BLOCKS

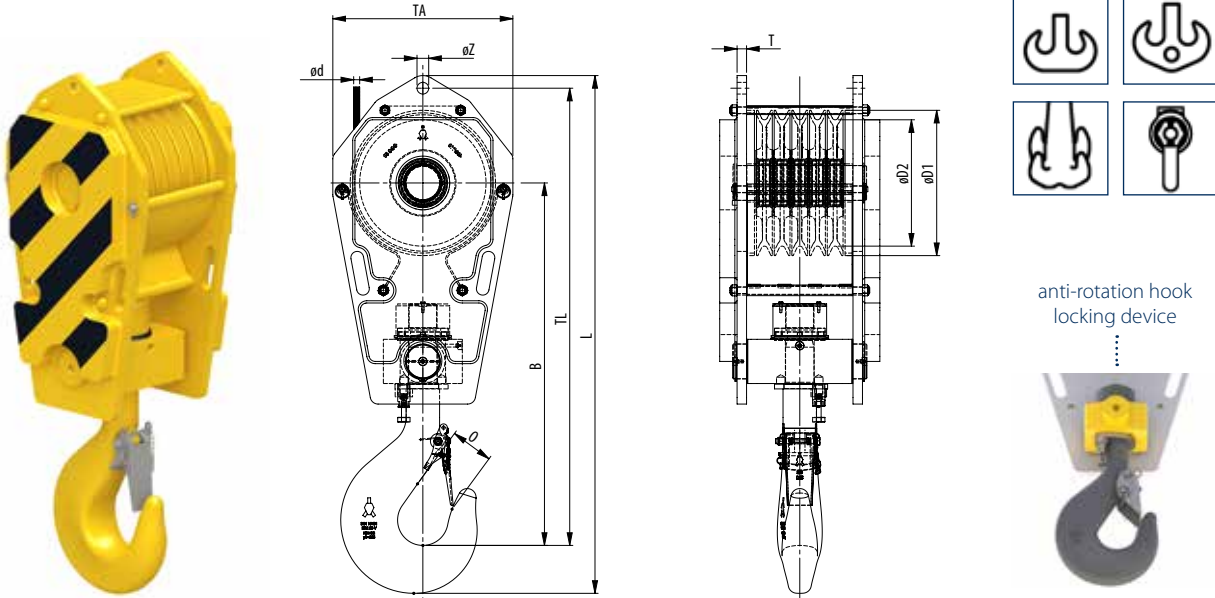

Model No.	WLL (UStons)	For wire ød (inch)	Hook size	Dimensions (inch)									Weight (lbs)
				øD1	øD2	B	O	TA	TL	L	T	øZ	
FRB 355.xx.5.50.E	55	5/16 - 7/8	12	16.1	14	37.8	3.9	19.7	48.2	54.3	TBD	TBD	840
FRB 355.xx.5.55.E	60	5/16 - 7/8	12	16.1	14	37.8	3.9	19.7	48.2	52.8	TBD	TBD	1100 1280
FRB 360.xx.5.64.E	70	5/8 - 7/8	16	16.5	14.2	39.3	4.4	20.1	49.9	56.8	TBD	TBD	1340 1550
FRB 400.xx.5.68.E	75	5/8 - 1	16	18.1	15.7	40.2	4.4	22.4	51.8	58.6	TBD	TBD	1470 1720
FRB 360.xx.5.70.E	77	5/8 - 7/8	16	16.5	14.2	39.3	4.4	20.1	49.9	56.8	TBD	TBD	1340 1550
FRB 400.xx.5.70.E	77	5/8 - 1	16	18.1	15.7	39.8	4.4	22.4	51.4	58.4	TBD	TBD	1340
FRB 360.xx.5.72.E	80	5/8 - 7/8	16	16.5	14.2	39.6	4.4	20.1	50.2	57.1	TBD	TBD	1340 1550
FRB 400.xx.5.82.E	90	5/8 - 1	20	18.1	15.7	45.2	4.9	22.4	57	62.9	TBD	TBD	1477 1540 1600 1800
FRB 400.xx.5.91.E	100	5/8 - 1	20	18.1	15.7	45.2	4.9	22.4	57	65.2	TBD	TBD	2250
FRB 450.xx.5.91.E	100	3/4 - 1 1/8	20	20.3	17.7	46.7	4.9	23.6	59.9	67.9	TBD	TBD	2250
FRB 400.xx.5.95.E	105	5/8 - 1	20	18.1	15.7	40.7	4.9	22.4	53.1	59.9	TBD	TBD	2250 2870
FRB 400.xx.5.100.E	110	5/8 - 1	20	18.1	15.7	40.7	4.9	22.4	53.1	59.9	TBD	TBD	2250
FRB 450.xx.5.100.E	110	3/4 - 1 1/8	25	20.3	17.7	49.7	5.5	23.6	62.9	69.6	TBD	TBD	1900 2200 2250 2510
FRB 528.xx.5.100.E	110	7/8 - 1 1/4	25	23.4	20.8	49.9	5.5	28	65.9	74.6	TBD	TBD	2500 2800
FRB 528.xx.5.100.E	110	7/8 - 1 1/4	25	23.4	20.8	50.9	5.5	31.1	66	75.1	TBD	TBD	2860 3960 5060*
FRB 575.xx.5.100.D	110	1 1/16 - 1 1/4	25	25.6	22.6	33.7	5.5	30.3	70.2	78.4	TBD	TBD	2860 3960 5060*
FRB 528.xx.5.119.E	130	7/8 - 1 1/4	25	23.4	20.8	52.1	5.5	27.9	67.6	76.6	TBD	TBD	3300
FRB 450.xx.5.125.D	137.5	3/4 - 1 1/8	32	20.3	17.7	50.7	6.3	23.6	63.7	72.1	TBD	TBD	3630

Minimum Ultimate Strength = 4 x WLL

xx = to be replaced by metric wire size in final part number; TBD = these dimensions vary with wire size;
 * blocks can be fitted with removable / interchangeable cheek weights

- The dimensions in this table are indicative only. A drawing will always be submitted prior to production and will be the leading document when discussing dimensions.
- Blocks shown here are standard models; inquiries for custom versions are welcome.
- Refer to wire rope manufacturers D/d ratio guideline.
- Hook locking pin included on all blocks 45UStons and higher.



SEE OUR WARNING & SAFETY INFORMATION ON PAGES 136 - 149



SEE OUR WARNING AND SAFETY INFORMATION ON PAGE 136



<< FAST REEVE CRANE BLOCKS

5 SHEAVES

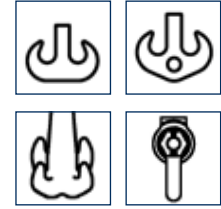
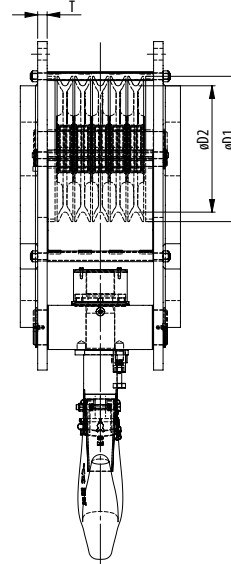
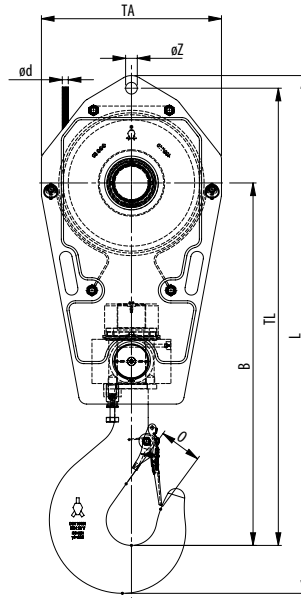

anti-rotation hook locking device



Model No.	WLL (UStons)	For wire ød (inch)	Hook size	Dimensions (inch)									Weight (lbs)
				øD1	øD2	B	O	TA	TL	L	T	øZ	
FRB 528.xx.5.125.E	137.5	7/8 - 1¼	32	23.4	20.8	52.5	6.3	28	67.8	75.3	TBD	TBD	3500 3960
FRB 528.xx.5.129,2.E	142	7/8 - 1¼	32	23.4	20.8	56.8	6.3	27.9	71.8	81.6	TBD	TBD	5060
FRB 450.xx.5.137.D	150	¾ - 1½	32	20.3	17.7	50.8	6.3	23.6	64.6	72	TBD	TBD	3630
FRB 528.xx.5.137.E	150	7/8 - 1¼	32	23.4	20.8	54.4	6.3	28	69.8	79.7	TBD	TBD	3500
FRB 670.xx.5.137.D	150	1 - 1½	32	29.9	26.4	56.6	6.3	34.3	75.7	85.3	TBD	TBD	6000*
FRB 630.xx.5.150.E	165	1 - 1¾	32	27.9	24.8	58.8	6.3	32.7	77.9	85.4	TBD	TBD	4600 6100*
FRB 528.xx.5.160.E	176	7/8 - 1¼	40	23.4	20.8	59.1	7.1	28	77.9	86.3	TBD	TBD	4000 4500
FRB 575.xx.5.160.E	176	15/16 - 1¼	40	25.6	22.6	62.6	7.1	30.3	79.2	87.5	TBD	TBD	5500
FRB 630.xx.5.160.D	176	1 - 1¾	40	27.9	24.8	57.6	7.1	32.7	75.3	85.4	TBD	TBD	5500
FRB 670.xx.5.160.E	176	1 - 1½	40	29.9	26.4	62.6	7.1	34.3	81.1	92	TBD	TBD	6000*
FRB 528.xx.5.182.D	200	7/8 - 1¼	40	23.4	20.8	58.1	7.1	27.9	73.4	86.5	TBD	TBD	3860
FRB 575.xx.5.182.D	200	15/16 - 1¼	40	25.6	22.6	62.6	7.1	30.3	79.2	90.2	TBD	TBD	5500
FRB 630.xx.5.182.E	200	1 - 1¾	40	27.9	24.8	62.3	7.1	32.7	79.4	89.8	TBD	TBD	5500 7500
FRB 670.xx.5.182.D	200	1 - 1½	40	29.9	26.4	67.6	7.1	34.3	86.9	96.1	TBD	TBD	6000*
FRB 630.xx.5.200.D	220	1 - 1¾	50	27.9	24.8	63.9	7.9	35.4	86.1	96.8	TBD	TBD	5000 up to 15400*

Minimum Ultimate Strength = 4 x WLL

xx = to be replaced by metric wire size in final part number; TBD = these dimensions vary with wire size;

* blocks can be fitted with removable / interchangeable cheek weights

- The dimensions in this table are indicative only. A drawing will always be submitted prior to production and will be the leading document when discussing dimensions.
- Blocks shown here are standard models; inquiries for custom versions are welcome.
- Refer to wire rope manufacturers D/d ratio guideline.
- Hook locking pin included on all blocks 45UStons and higher.



SEE OUR WARNING & SAFETY INFORMATION ON PAGES 136 - 149



FAST REEVE CRANE BLOCKS

6 SHEAVES

CRANE BLOCKS

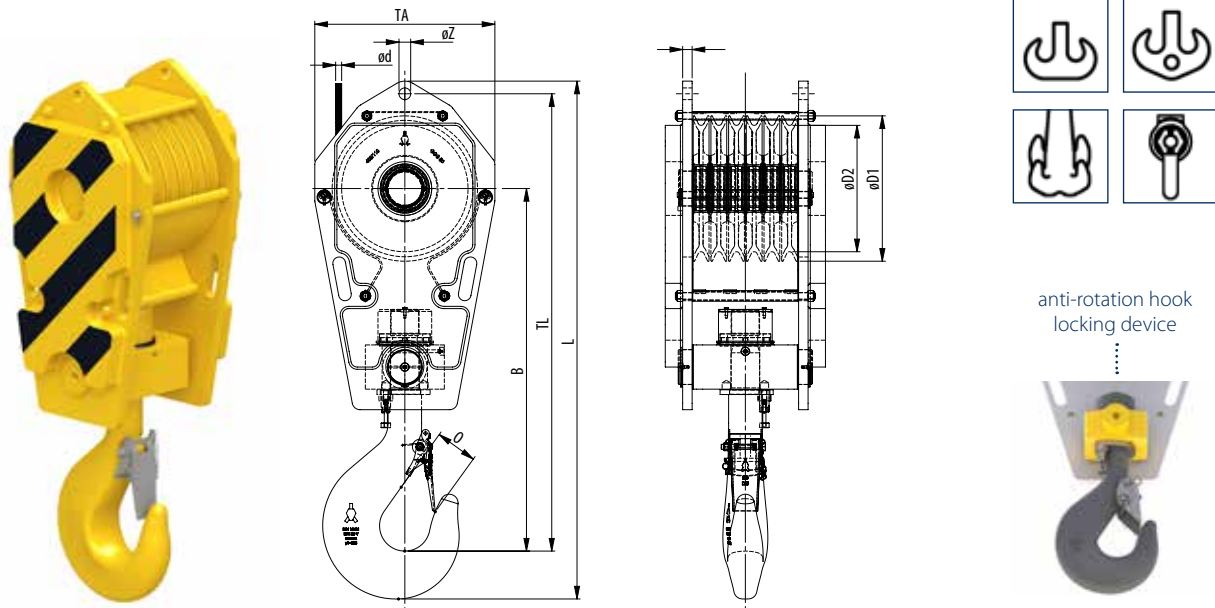

Model No.	WLL (UStons)	For wire ød (inch)	Hook size	Dimensions (inch)									Weight (lbs)
				øD1	øD2	B	O	TA	TL	L	T	øZ	
FRB 355.xx.6.55.E	55	5/16 - 7/8	12	16.1	14	35.8	3.9	19.7	46	52.4	TBD	TBD	1496
FRB 360.xx.6.64.E	70	5/8 - 7/8	16	16.5	14.2	38.3	4.4	20.1	48.9	50.3	TBD	TBD	1495
FRB 400.xx.6.64.E	70	5/8 - 1	16	18.1	15.7	41.9	4.4	22.4	53.7	60.5	TBD	TBD	1700
FRB 400.xx.6.82.E	90	5/8 - 1	20	18.1	15.7	45.2	4.9	22.4	57	62.9	TBD	TBD	1800
FRB 450.xx.6.82.E	90	3/4 - 1 1/8	20	20.3	17.7	46.7	4.9	23.6	62.2	68.1	TBD	TBD	2000
FRB 400.xx.6.91.E	100	5/8 - 1	20	18.1	15.7	44.6	4.9	22.4	56.4	64	TBD	TBD	1750 1800 2200
FRB 450.xx.6.100.E	110	3/4 - 1 1/8	25	20.3	17.7	49.7	5.5	23.6	62.9	69.6	TBD	TBD	2500
FRB 528.xx.6.100.E	110	7/8 - 1 1/4	25	23.4	20.8	50.1	5.5	28	64.9	73.4	TBD	TBD	2500
FRB 450.xx.6.120.E	132	3/4 - 1 1/8	25	20.3	17.7	47.9	5.5	22.4	59.8	68.1	TBD	TBD	2200
FRB 528.xx.6.137.E	150	7/8 - 1 1/4	32	23.4	20.8	52.5	6.3	28	67.8	77.8	TBD	TBD	3500
FRB 528.xx.6.150.E	165	7/8 - 1 1/4	40	23.5	20.8	61.1	7.1	28	79.5	87.9	TBD	TBD	4000
FRB 528.xx.6.160.E	176	7/8 - 1 1/4	40	23.5	20.8	62.2	7.1	28	77.8	86.1	TBD	TBD	4500 5000
FRB 528.xx.6.182.E	200	7/8 - 1 1/4	40	23.5	20.8	63	7.1	28	79.5	87.9	TBD	TBD	4500
FRB 575.xx.6.182.E	200	1 5/16 - 1 1/4	40	25.6	22.6	61.1	7.1	30.3	77.4	88.4	TBD	TBD	4500 5500
FRB 670.xx.6.182.E	200	1 - 1 1/2	40	29.9	26.4	61.7	7.1	34.3	80.2	90.2	TBD	TBD	5500
FRB 528.xx.6.200.E	220	7/8 - 1 1/4	50	23.5	20.8	63	7.9	28	79.5	87.9	TBD	TBD	5500
FRB 575.xx.6.209.E	230	1 5/16 - 1 1/4	50	25.6	22.6	65.4	7.9	30.3	81.9	91.2	TBD	TBD	6500

Minimum Ultimate Strength = 4 x WLL

- The dimensions in this table are indicative only. A drawing will always be submitted prior to production and will be the leading document when discussing dimensions.
- Blocks shown here are standard models; inquiries for custom versions are welcome.
- Refer to wire rope manufacturers D/d ratio guideline.
- Optional: Hook locking pin.



SEE OUR WARNING & SAFETY INFORMATION ON PAGES 136 - 149

SEE OUR WARNING AND SAFETY INFORMATION ON PAGE 136



FAST REEVE CRANE BLOCKS

7 SHEAVES

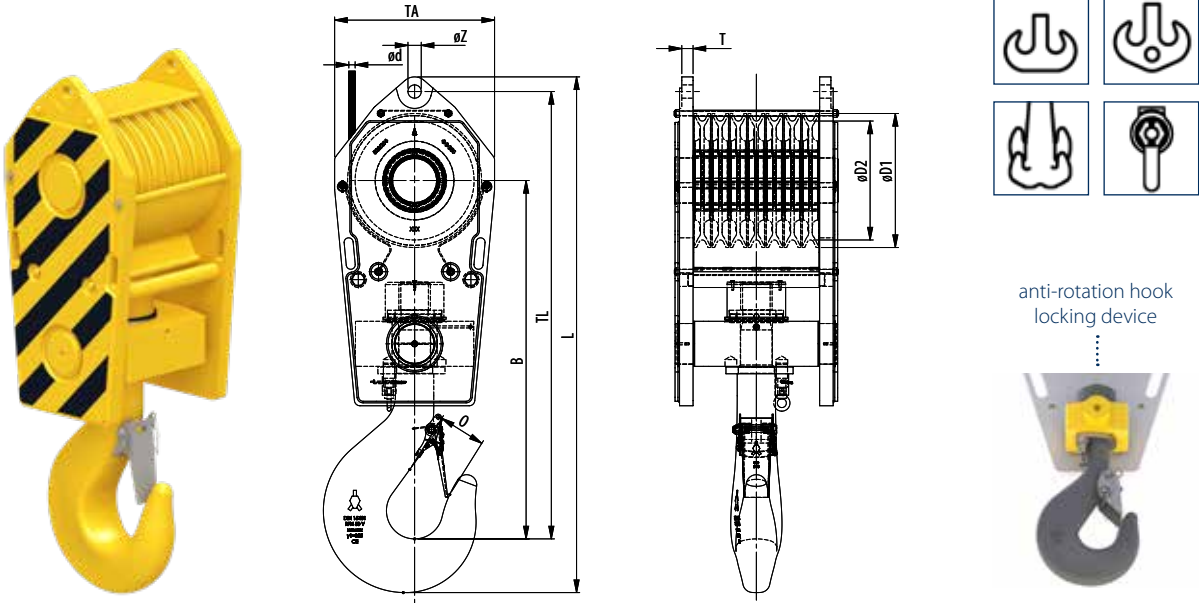

Model No.	WLL (UStons)	For wire ød (inch)	Hook size	Dimensions (inch)									Weight (lbs)
				øD1	øD2	B	O	TA	TL	L	T	øZ	
FRB 355.xx.7.75.E	82.5	5/16 - 7/8	16	16.1	14	39.2	4.4	18.9	49.8	56.8	TBD	TBD	1600
FRB 400.xx.7.100.E	110	5/8 - 1	20	18.1	15.7	43.6	4.9	22.4	55.6	63.4	TBD	TBD	2400
FRB 400.xx.7.118.E	130	5/8 - 1	25	18.1	15.7	48.9	5.5	22.4	60.9	69.4	TBD	TBD	2400
FRB 400.xx.7.127.D	140	5/8 - 1	32	18.1	15.7	47.8	6.3	22.4	59.8	68.3	TBD	TBD	2850
FRB 450.xx.7.127.E	140	3/4 - 1 1/8	32	20.3	17.7	54.3	6.3	23.6	67.4	76.9	TBD	TBD	3150
FRB 450.xx.7.137.E	150	3/4 - 1 1/8	32	20.3	17.7	54.3	6.3	23.6	67.4	76.9	TBD	TBD	3100
FRB 450.xx.7.160.D	176	3/4 - 1 1/8	40	20.3	17.7	58.2	7.1	23.6	71.4	80.8	TBD	TBD	3930
FRB 528.xx.7.160.D	176	7/8 - 1 1/4	40	23.4	20.8	58.6	7.1	31.1	73.9	83.5	TBD	TBD	3300 4950 6600*
FRB 528.xx.5.171.D	188	7/8 - 1 1/4	40	23.4	20.8	55.9	7.1	31.1	71.1	81	TBD	TBD	5940
FRB 575.xx.7.171.D	188	1 1/16 - 1 1/4	40	25.6	22.6	56.8	7.1	30.4	72.7	82.6	TBD	TBD	5940
FRB 528.xx.7.182.E	200	7/8 - 1 1/4	40	23.4	20.8	59.5	7.1	27.9	74.3	85.4	TBD	TBD	6160
FRB 528.xx.7.200.D	220	7/8 - 1 1/4	50	23.4	20.8	58.8	7.9	27.9	74.3	84.2	TBD	TBD	5280
FRB 575.xx.7.209.D	230	1 1/16 - 1 1/4	50	25.6	22.6	59.9	7.9	30.3	76.4	87.4	TBD	TBD	6500 7500
FRB 575.xx.7.209.D	230	1 1/16 - 1 1/4	50	25.6	22.6	59.9	7.9	30.3	76.4	87.5	TBD	TBD	5500 7500 8500*
FRB 575.xx.7.209.D	230	1 1/16 - 1 1/4	50	25.6	22.6	59.9	7.9	30.3	76.4	87.5	TBD	TBD	5500 7500 9500*
FRB 630.xx.7.209.D	230	1 - 1 3/8	50	27.9	24.8	60.8	7.9	32.6	78.4	89.6	TBD	TBD	5500 7500 9500*
FRB 670.xx.7.209.D	230	1 - 1 1/2	50	29.9	26.4	63.1	7.9	34.3	82.2	93.1	TBD	TBD	6500* 9500**
FRB 670.xx.7.228.D	250	1 - 1 1/2	50	29.9	26.4	63.1	7.9	34.3	82.2	93.1	TBD	TBD	6500 7700*
FRB 670.xx.7.250.DB	275	1 - 1 1/2	63	29.9	26.4	64.6	8.8	34.3	83.8	99.5	TBD	TBD	10000*
FRB 528.xx.7.272.D	300	7/8 - 1 1/4	63	23.4	20.8	61.8	8.8	27.9	77.2	88.8	TBD	TBD	6450

Minimum Ultimate Strength = 4 x WLL

xx = to be replaced by metric wire size in final part number; TBD = these dimensions vary with wire size;

* blocks can be fitted with removable / interchangeable cheek weights

- The dimensions in this table are indicative only. A drawing will always be submitted prior to production and will be the leading document when discussing dimensions.
- Blocks shown here are standard models; inquiries for custom versions are welcome.
- Refer to wire rope manufacturers D/d ratio guideline.
- Hook locking pin included on all blocks 45UStons and higher.

SEE OUR WARNING & SAFETY INFORMATION ON PAGES 136 - 149





CONSTRUCTION SPECIFIC BLOCKS

STANDARD REEVE CRANE BLOCKS

Ropeblock Standard Reeve Crane Blocks are suitable for use on a wide variety of mobile cranes, crawler cranes and other land-based cranes. These blocks are an excellent choice when frequent easy block change is not a required main feature, or lifting height is limited.

Standard features include:

- Design factor: 4:1
- Double-sealed maintenance-free roller bearings
- Forged high tensile steel DIN/EN hooks
- Cast sheaves featuring graphite lubricated groove
- Robust design
- Operational temperature range: -40 up to +80°C / -40 up to +176°F
- Lubrication on hook suspension
- Short design for increased lifting height
- C3M finish in signal yellow
- Safety latch with locking pin

PLEASE CONTACT US FOR MORE DETAILS

THE ANATOMY OF A ROPEBLOCK CRANE BLOCK PRODUCT NUMBER

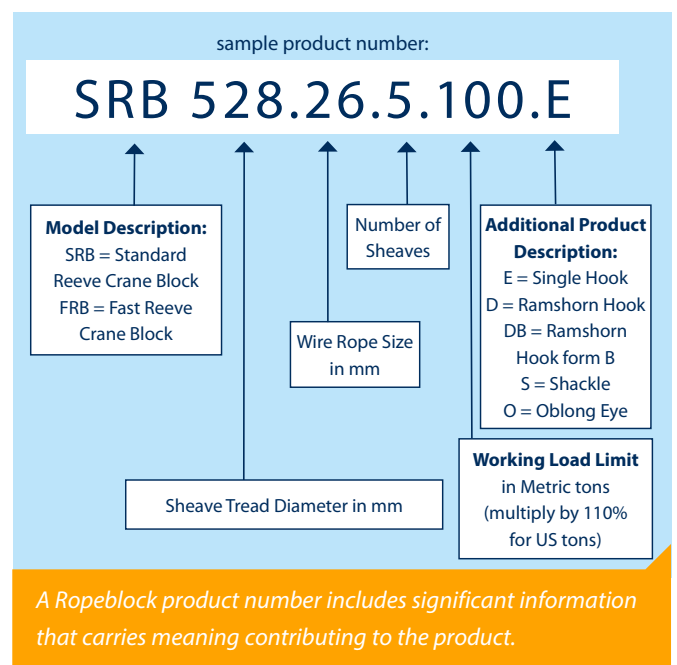

STANDARD REEVE CRANE BLOCKS

1 SHEAVE

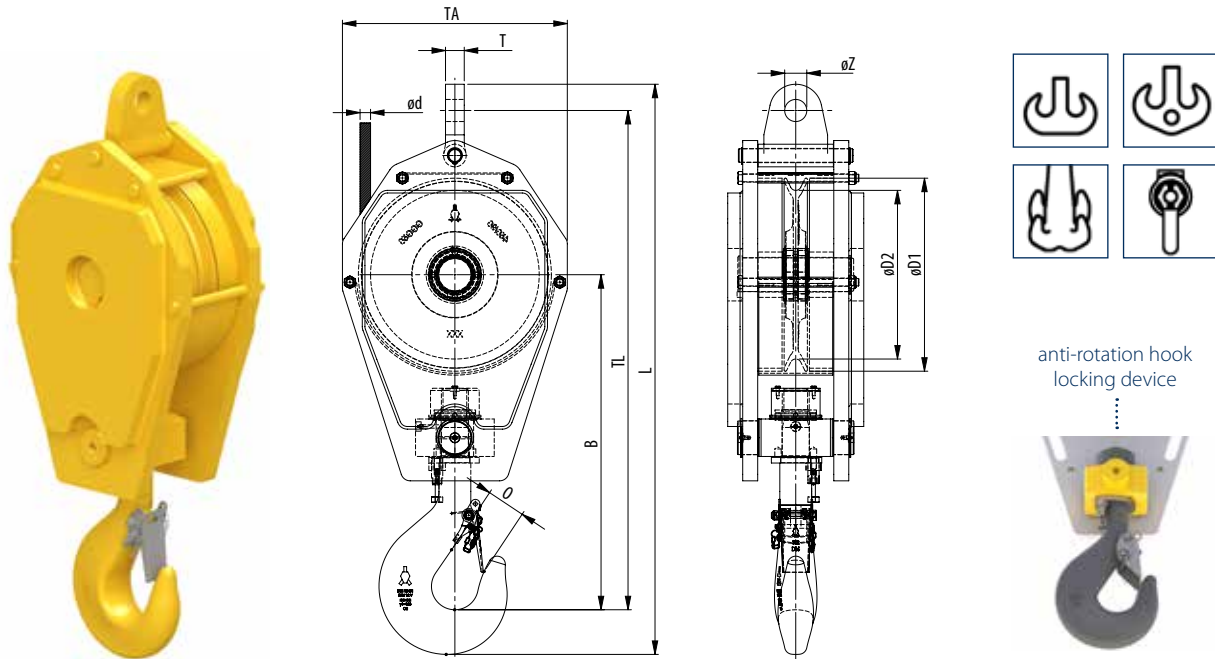

Model No.	WLL (UStons)	For wire ød (inch)	Hook size	Dimensions (inch)									Weight (lbs)
				øD1	øD2	B	O	TA	TL	L	T	øZ	
SRB 225.xx.1.12,5.E	13.7	3/8 - 9/16	5	10.2	8.9	20.6	2.5	13.6	31.4	35.9	TBD	TBD	165
SRB 260.xx.1.12,5.E	13.7	7/16 - 5/8	5	11.8	10.2	21.6	2.5	15.7	32.8	37.3	TBD	TBD	240
SRB 225.xx.1.16.E	17.6	3/8 - 9/16	6	10.2	8.9	21.6	2.5	13.6	32.4	36.9	TBD	TBD	220
SRB 260.xx.1.16.E	17.6	7/16 - 5/8	6	11.8	10.2	21.6	2.5	15.7	32.8	37.3	TBD	TBD	240
SRB 285.xx.1.16.E	17.6	1/2 - 3/4	6	12.6	11	23.9	2.8	16.5	35.7	40.7	TBD	TBD	350
SRB 320.xx.1.16.E	17.6	9/16 - 3/4	6	14.4	12.6	24.7	2.8	17.7	37.4	42.6	TBD	TBD	350
SRB 355.xx.1.16.E	17.6	9/16 - 7/8	6	16.1	14	26.3	2.8	19.7	39.9	44.8	TBD	TBD	400
SRB 320.xx.1.20.E	22	9/16 - 3/4	8	14.4	12.6	27.1	3.1	17.7	39.8	45.4	TBD	TBD	350
SRB 355.xx.1.20.E	22	9/16 - 7/8	8	16.1	14	28.1	3.1	19.7	41.5	47.4	TBD	TBD	550
SRB 450.xx.1.25.E	27.5	3/4 - 1 1/8	8	20.3	17.7	30.3	3.1	23.6	46.8	52.9	TBD	TBD	435
SRB 528.xx.1.28.E	30	7/8 - 1 1/4	8	23.5	20.8	33	3.1	27.9	52	58.6	TBD	TBD	600
SRB 400.xx.1.29.E	32	5/8 - 1	8	18.1	15.7	29.3	3.1	22.4	44.4	50.1	TBD	TBD	640
SRB 450.xx.1.32.E	35	3/4 - 1 1/8	10	20.3	17.7	32.8	3.5	23.6	49.4	56	TBD	TBD	1000 1100
SRB 528.xx.1.32.E	35	7/8 - 1 1/4	10	23.5	20.8	35.4	3.5	28	53.6	60.2	TBD	TBD	1100 1400 2000
SRB 450.xx.1.40.E	45	3/4 - 1 1/8	12	20.3	17.7	42.3	3.9	23.6	58.5	65.6	TBD	TBD	1300
SRB 450.xx.1.50.E	55	3/4 - 1 1/8	12	20.3	17.7	36.1	3.9	23.8	52.7	59.7	TBD	TBD	1300
SRB 528.xx.1.50.E	55	7/8 - 1 1/4	12	23.5	20.8	36.8	3.9	28	55.6	63.1	TBD	TBD	1650
SRB 575.xx.1.50.E	55	1 5/16 - 1 1/4	12	25.6	22.6	37.7	3.9	30.3	57.4	65.4	TBD	TBD	2045
SRB 630.xx.1.64.E	70	1 - 1 3/8	16	28.3	24.8	38.8	4.4	32.5	59.9	68	TBD	TBD	2200
SRB 670.xx.1.64.E	70	1 - 1 1/2	16	29.9	26.4	46.2	4.4	34.3	68.4	76.6	TBD	TBD	3000

Minimum Ultimate Strength = 4 x WLL

xx = to be replaced by metric wire size in final part number; TBD = these dimensions vary with wire size;

* blocks can be fitted with removable / interchangeable cheek weights

- The dimensions in this table are indicative only. A drawing will always be submitted prior to production and will be the leading document when discussing dimensions.
- Blocks shown here are standard models; inquiries for custom versions are welcome.
- Refer to wire rope manufacturers D/d ratio guideline.
- Hook locking pin included on all blocks 45UStons and higher.



SEE OUR WARNING & SAFETY INFORMATION ON PAGES 136 - 149



STANDARD REEVE CRANE BLOCKS

2 SHEAVES

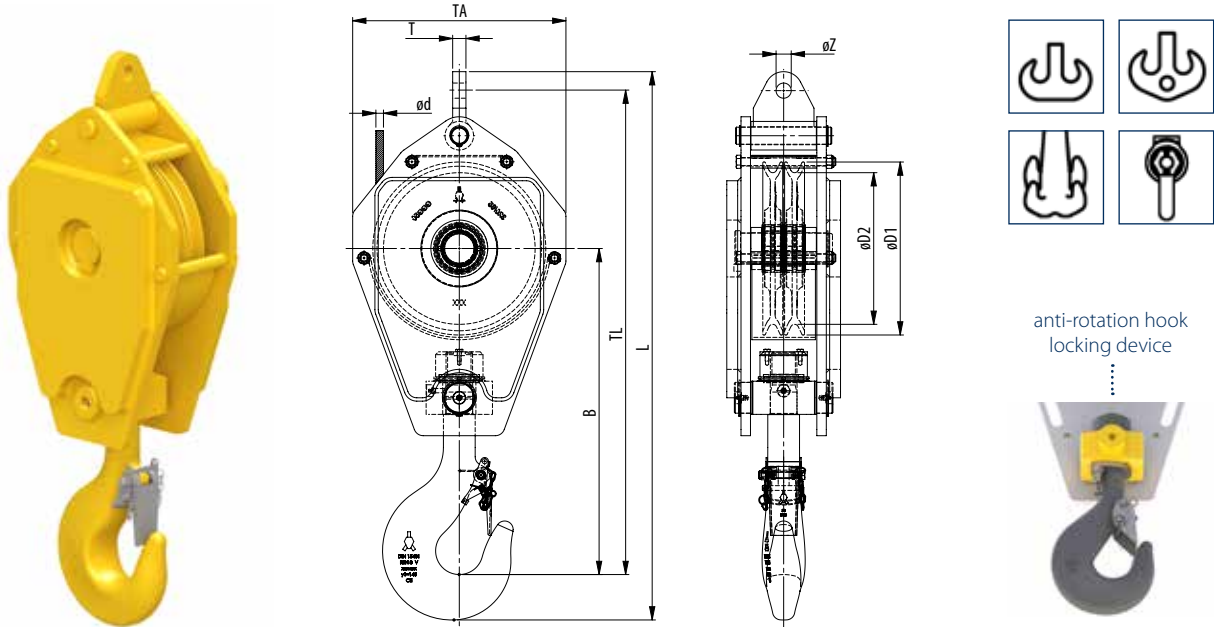

Model No.	WLL (UStons)	For wire ød (inch)	Hook size	Dimensions (inch)									Weight (lbs)
				øD1	øD2	B	O	TA	TL	L	T	øZ	
SRB 225.xx.2.16.E	17.6	3/8 - 5/16	6	11.8	10.2	23.3	2.8	15.7	34.6	39.5	TBD	TBD	240
SRB 260.xx.2.16.E	17.6	7/16 - 5/8	6	11.8	10.2	23.3	2.8	15.7	34.6	39.5	TBD	TBD	285 350
SRB 285.xx.2.16.E	17.6	1/2 - 3/4	6	12.6	11	23.9	2.8	16.5	35.7	40.7	TBD	TBD	210
SRB 260.xx.2.20.E	22	7/16 - 5/8	8	11.8	10.2	26.7	3.1	15.7	43	38	TBD	TBD	285 350
SRB 285.xx.2.20.E	22	1/2 - 3/4	8	12.6	11	26.3	3.1	16.5	38.1	43.4	TBD	TBD	285 330
SRB 320.xx.2.20.E	22	9/16 - 3/4	8	14.4	12.6	27.1	3.1	17.7	39.8	45.1	TBD	TBD	350
SRB 320.xx.2.22.E	24	9/16 - 3/4	8	14.4	12.6	27.1	3.1	17.7	39.8	45.6	TBD	TBD	350
SRB 260.xx.2.25.E	27.5	7/16 - 5/8	8	11.8	10.2	26.5	3.1	15.7	37.7	42.8	TBD	TBD	350
SRB 320.xx.2.25.E	27.5	9/16 - 3/4	8	14.4	12.6	27.1	3.1	17.7	39.8	45.1	TBD	TBD	450
SRB 355.xx.2.29.E	32	9/16 - 7/8	8	16.1	14	28.1	3.1	19.7	41.9	47.4	TBD	TBD	550
SRB 400.xx.2.29.E	32	5/8 - 1	8	18.1	15.7	29.3	3.1	22.4	44.4	50.1	TBD	TBD	705
SRB 450.xx.2.40.E	45	3/4 - 1 1/8	12	20.3	17.7	35.2	3.9	23.6	52	58.1	TBD	TBD	1210
SRB 450.xx.2.50.E	55	3/4 - 1 1/8	12	20.3	17.7	35.2	3.9	23.6	52	59.6	TBD	TBD	1210
SRB 400.xx.2.55.E	60	5/8 - 1	12	18.1	15.7	34	3.9	22.4	48.9	55.6	TBD	TBD	800
SRB 528.xx.2.64.E	70	7/8 - 1 1/4	16	23.4	20.8	39.5	4.4	28	58.4	65.9	TBD	TBD	2155
SRB 528.xx.2.80.E	88	7/8 - 1 1/4	20	23.4	20.8	43.7	4.9	28	62.6	71.2	TBD	TBD	2200
SRB 670.xx.2.100.E	110	1 - 1 3/8	20	29.9	26.4	49.5	4.9	34.3	71.7	80.4	TBD	TBD	4930

Minimum Ultimate Strength = 4 x WLL

xx = to be replaced by metric wire size in final part number; TBD = these dimensions vary with wire size;

* blocks can be fitted with removable / interchangeable cheek weights

- The dimensions in this table are indicative only. A drawing will always be submitted prior to production and will be the leading document when discussing dimensions.
- Blocks shown here are standard models; inquiries for custom versions are welcome.
- Refer to wire rope manufacturers D/d ratio guideline.
- Hook locking pin included on all blocks 45UStons and higher.



SEE OUR WARNING & SAFETY INFORMATION ON PAGES 136 - 149



STANDARD REEVE CRANE BLOCKS

3 SHEAVES

CRANE BLOCKS

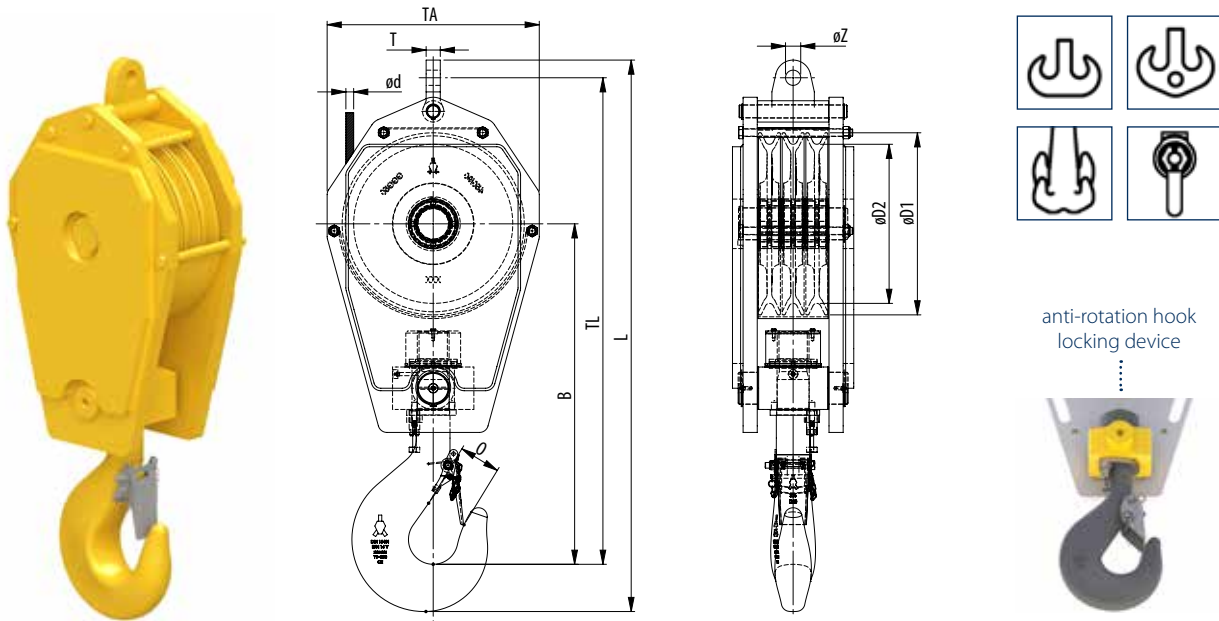

Model No.	WLL (UStons)	For wire ød (inch)	Hook size	Dimensions (inch)									Weight (lbs)
				øD1	øD2	B	O	TA	TL	L	T	øZ	
SRB 260.xx.3.25.E	27.5	7/16 - 5/8	8	11.8	10.2	25.9	3.1	15.7	37.5	42.8	TBD	TBD	465
SRB 285.xx.3.29.E	32	1/2 - 3/4	8	12.8	11.2	26.3	3.1	15.7	38.5	43.8	TBD	TBD	465
SRB 320.xx.3.29.E	32	9/16 - 3/4	8	14.4	12.6	28.1	3.1	17.7	41.3	46.6	TBD	TBD	495
SRB 355.xx.3.32.E	35	9/16 - 7/8	10	16.1	14	29.6	3.5	19.7	43	49	TBD	TBD	715
SRB 360.xx.3.40.E	44	5/8 - 7/8	12	16.1	14.2	33	3.9	19.7	46.4	52.8	TBD	TBD	1000
SRB 400.xx.3.40.E	44	5/8 - 1	12	18.1	15.7	34	3.9	22.4	49	55.6	TBD	TBD	1100
SRB 400.xx.3.50.E	55	5/8 - 1	12	18.1	15.7	34	3.9	22.4	49	56.1	TBD	TBD	1100 1200
SRB 450.xx.3.50.E	55	3/4 - 1 1/8	16	20.3	17.7	38.6	4.4	23.6	53.5	60.3	TBD	TBD	1450
SRB 360.xx.3.55.E	60	5/8 - 7/8	12	16.1	14.2	33	3.9	19.7	46.4	52.9	TBD	TBD	1000
SRB 400.xx.3.55.E	60	5/8 - 1	12	18.1	15.7	34	3.9	22.4	49	55.6	TBD	TBD	1200
SRB 450.xx.3.64.E	70	3/4 - 1 1/8	16	20.3	17.7	37.9	4.4	23.6	54.2	61.3	TBD	TBD	1500 1700
SRB 450.xx.3.70.E	77	3/4 - 1 1/8	16	20.3	17.7	38.3	4.4	23.6	55	62.9	TBD	TBD	1500 1650
SRB 528.xx.3.73.E	80	7/8 - 1 1/4	16	23.4	20.8	41.6	4.4	27.9	59.4	67.5	TBD	TBD	2350
SRB 528.xx.3.82.E	90	7/8 - 1 1/4	20	23.4	20.8	44.6	4.9	28	63.5	71.7	TBD	TBD	2500
SRB 528.xx.3.100.E	110	7/8 - 1 1/4	25	23.4	20.8	48.1	5.5	28	66.3	75.3	TBD	TBD	2800
SRB 670.xx.3.125.E	137.5	1 - 1 3/8	25	29.9	26.4	53.3	5.5	34.3	75.5	85	TBD	TBD	6380

Minimum Ultimate Strength = 4 x WLL

xx = to be replaced by metric wire size in final part number; TBD = these dimensions vary with wire size;

* blocks can be fitted with removable / interchangeable cheek weights

- The dimensions in this table are indicative only. A drawing will always be submitted prior to production and will be the leading document when discussing dimensions.
- Blocks shown here are standard models; inquiries for custom versions are welcome.
- Refer to wire rope manufacturers D/d ratio guideline.
- Hook locking pin included on all blocks 45UStons and higher.



SEE OUR WARNING & SAFETY INFORMATION ON PAGES 136 - 149

SEE OUR WARNING AND SAFETY INFORMATION ON PAGE 136



STANDARD REEVE CRANE BLOCKS

4 SHEAVES

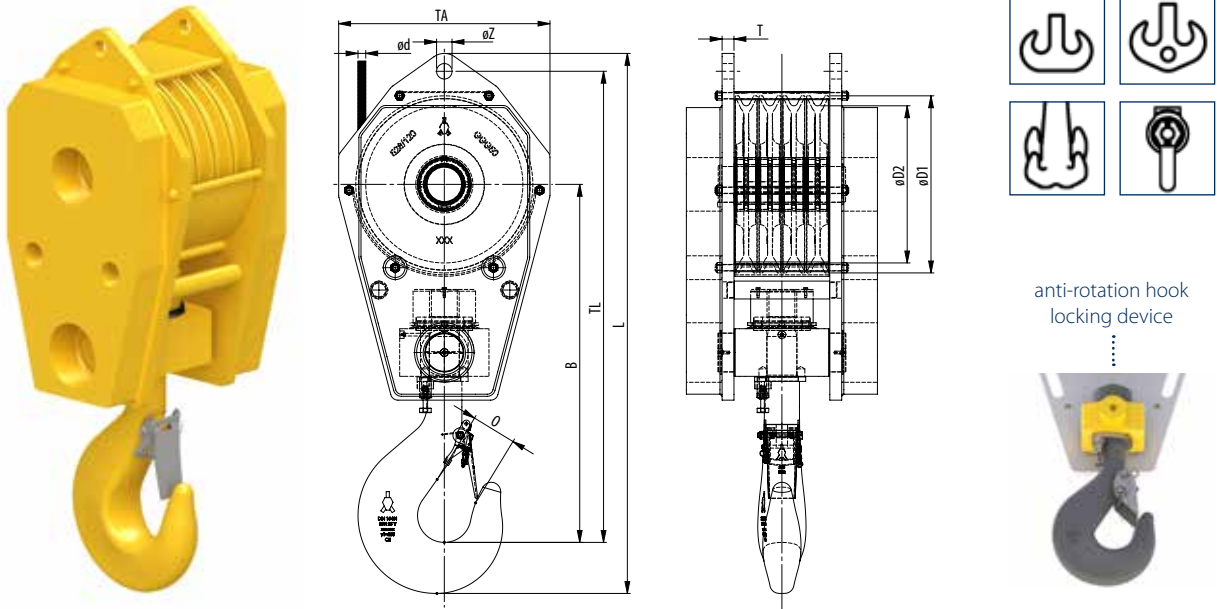

Model No.	WLL (UStons)	For wire ød (inch)	Hook size	Dimensions (inch)									Weight (lbs)
				øD1	øD2	B	O	TA	TL	L	T	øZ	
SRB 285.xx.4.35.E	38.5	1/2 - 3/4	10	12.8	11.2	26	3.5	15.7	36.2	40.4	TBD	TBD	570
SRB 355.xx.4.50.E	55	5/16 - 7/8	12	16.1	14	33	3.9	19.7	43.9	50.8	TBD	TBD	1045
SRB 528.xx.4.55.E	60	7/8 - 1 1/4	12	23.5	20.8	38.5	3.9	28	53.5	60.6	TBD	TBD	2600
SRB 400.xx.4.64.E	70	5/8 - 1	16	18.1	15.7	35.6	4.4	22.4	47.2	54.4	TBD	TBD	1155
SRB 450.xx.4.64.E	70	3/4 - 1 1/8	16	20.3	17.7	38	4.4	23.6	52	59.2	TBD	TBD	1595
SRB 528.xx.4.70.E	77	7/8 - 1 1/4	16	23.5	20.8	40.4	4.4	28	55.3	63	TBD	TBD	3850
SRB 528.xx.4.73.E	80	7/8 - 1 1/4	16	23.5	20.8	40.4	4.4	28	55.3	63	TBD	TBD	2850
SRB 450.xx.4.82.E	90	3/4 - 1 1/8	20	20.3	17.7	41.2	4.9	23.6	51.6	59.8	TBD	TBD	2110
SRB 450.xx.4.82.E	90	3/4 - 1 1/8	20	20.3	17.7	41.2	4.9	23.6	51.6	59.8	TBD	TBD	2110
SRB 528.xx.4.105.E	115	7/8 - 1 1/4	25	23.4	20.8	48.1	5.5	28	62.7	71.8	TBD	TBD	3900
SRB 710.xx.4.105.E	115	1 1/8 - 1 1/2	25	31.5	28	53.3	5.5	35.4	73.9	84.4	TBD	TBD	3000
SRB 450.xx.4.108.E	120	3/4 - 1 1/8	25	20.3	17.7	46.8	5.5	23.6	60.2	68.9	TBD	TBD	3200
SRB 670.xx.4.160.E	176	1 - 1 3/8	40	29.9	26.4	60.7	7.1	34.3	82.9	94	TBD	TBD	6930

Minimum Ultimate Strength = 4 x WLL

xx = to be replaced by metric wire size in final part number; TBD = these dimensions vary with wire size;

* blocks can be fitted with removable / interchangeable cheek weights

- The dimensions in this table are indicative only. A drawing will always be submitted prior to production and will be the leading document when discussing dimensions.
- Blocks shown here are standard models; inquiries for custom versions are welcome.
- Refer to wire rope manufacturers D/d ratio guideline.
- Hook locking pin included on all blocks 45UStons and higher.



SEE OUR WARNING & SAFETY INFORMATION ON PAGES 136 - 149



STANDARD REEVE CRANE BLOCKS

5 SHEAVES

CRANE BLOCKS

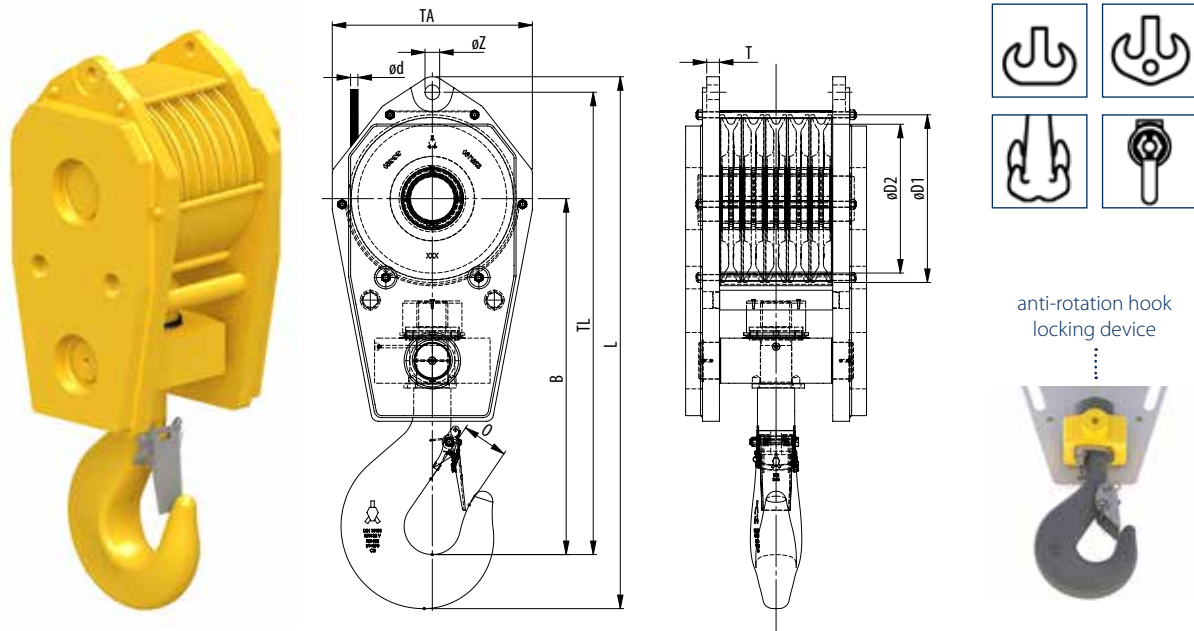

Model No.	WLL (UStons)	For wire ød (inch)	Hook size	Dimensions (inch)									Weight (lbs)
				øD1	øD2	B	O	TA	TL	L	T	øZ	
SRB 355.xx.5.55.E	60	5/16 - 7/8	12	16.1	14	33	4.4	19.7	44.6	51.4	TBD	TBD	1100
SRB 360.xx.5.64.E	70	5/8 - 7/8	16	16.1	14.2	39.1	4.4	19.7	47.2	54.1	TBD	TBD	1320
SRB 528.xx.5.70.E	77	7/8 - 1 1/4	16	23.4	20.8	40.8	4.4	27.9	55.7	63.1	TBD	TBD	2800
SRB 400.xx.5.73.E	80	5/8 - 1	16	18.1	15.7	37.6	4.4	22.4	49.6	56.7	TBD	TBD	1650
SRB 360.xx.5.80.E	88	5/8 - 7/8	20	16.1	14.2	39.1	4.9	19.7	50.5	58.1	TBD	TBD	1805
SRB 400.xx.5.82.E	90	5/8 - 1	20	18.1	15.7	40.7	4.9	22.4	53.7	61.6	TBD	TBD	1800
SRB 450.xx.5.82.E	90	3/4 - 1 1/8	20	20.3	17.7	42.2	4.9	23.6	56.3	64.2	TBD	TBD	2250
SRB 450.xx.5.100.E	110	3/4 - 1 1/8	25	20.3	17.7	44.4	5.5	23.6	58.5	67.6	TBD	TBD	2500
SRB 528.xx.5.125.E	137.5	7/8 - 1 1/4	32	23.4	20.8	49.7	6.3	28	66.8	76.6	TBD	TBD	3500
SRB 528.xx.5.137,5.E	150	7/8 - 1 1/4	32	23.4	20.8	52.5	6.3	28	50.1	77.8	TBD	TBD	3500
SRB 528.xx.5.160.E	176	7/8 - 1 1/4	40	23.4	20.8	55.4	7.1	28	70.7	81.8	TBD	TBD	3640
FRB 670.xx.5.200.E	220	1 - 1 3/8	50	29.9	26.4	64.6	7.9	34.3	83.9	95.9	TBD	TBD	7830

Minimum Ultimate Strength = 4 x WLL

xx = to be replaced by metric wire size in final part number; TBD = these dimensions vary with wire size;

* blocks can be fitted with removable / interchangeable cheek weights

- The dimensions in this table are indicative only. A drawing will always be submitted prior to production and will be the leading document when discussing dimensions.
- Blocks shown here are standard models; inquiries for custom versions are welcome.
- Refer to wire rope manufacturers D/d ratio guideline.
- Hook locking pin included on all blocks 45UStons and higher.



SEE OUR WARNING & SAFETY INFORMATION ON PAGES 136 - 149

SEE OUR WARNING AND SAFETY INFORMATION ON PAGE 136



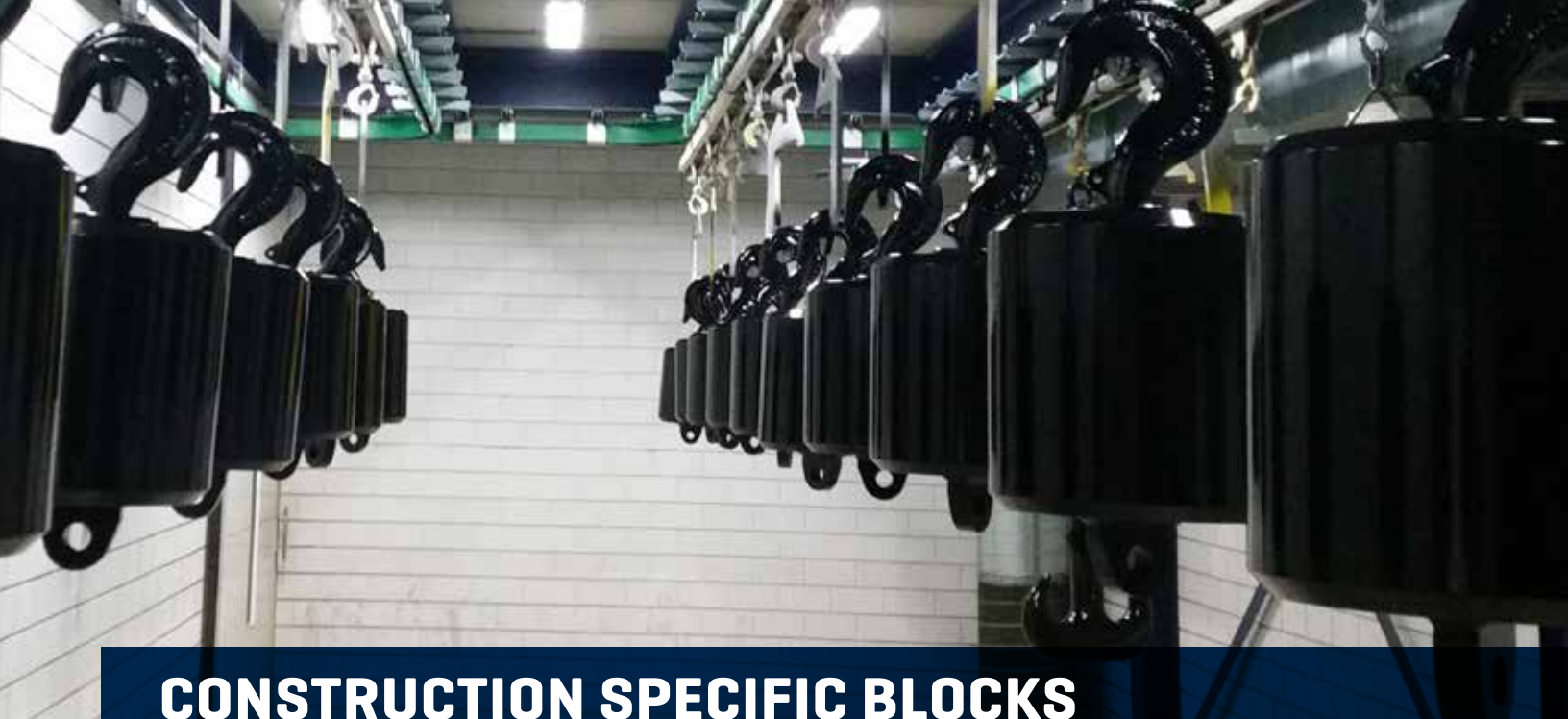

CONSTRUCTION SPECIFIC BLOCKS

OVERHAUL BALLS

In Ropeblock Overhaul Balls, weights are based on average boom lengths and efficiency loss in mobile cranes and crawler cranes. The low friction and easy to access hook swivel design makes these overhaul balls an excellent choice for a wide variety of crane applications.

Standard features include:

- Design factor: 4:1
- Bottom and top swiveling hook
- High quality, low friction thrust bearing

- Becket size optimized for Ropeblock Sockets such as Open Wedge Sockets (OWS), Open Spelter Sockets (OSS), Fast Connector Sockets (FCS) or Super Reeve Connector Sockets (SCS)
- Forged high tensile steel DIN/EN hooks
- Body made of forged bar material
- Operational temperature range: -40 up to +80°C / -40 up to +176°F
- Robust design
- C3M finish, signal yellow

PLEASE CONTACT US FOR MORE DETAILS



OVERHAUL BALLS

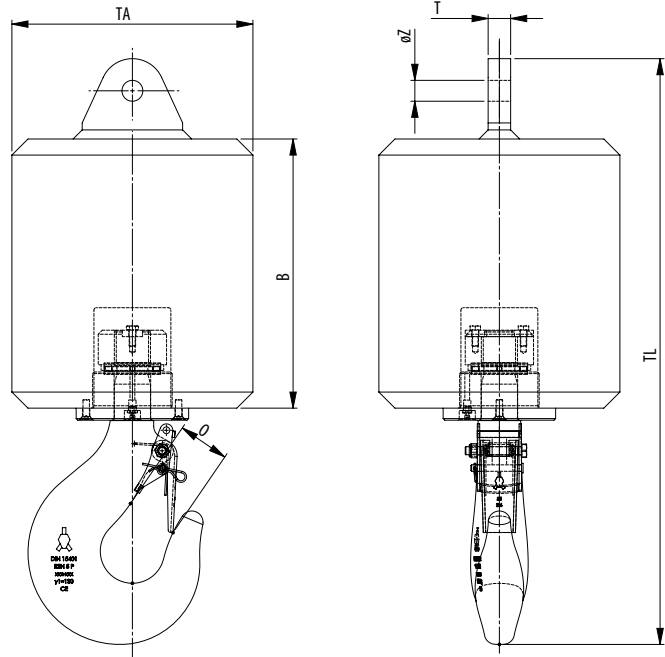

Model No.	WLL (UStons)	For wire ød (inch)	Hook	Becket	Dimensions (inch)						Weight (lbs)
					B	O	TA	TL	T	øZ	
OHB 3,2.60.C-1	3.5	½	2.5	1	7.9	2.0	8.7	19.7	0.9	1.1	130
OHB 3,2.60.C-2	3.5	⅝ - ⅞	2.5	2	7.9	2.0	8.7	19.9	1.1	1.3	130
OHB 5.80.C-2	5.5	⅝ - ⅞	2.5	2	8.7	2.0	9.4	22.3	1.1	1.3	175
OHB 6,3.80.C-2	6.9	⅝ - ⅞	2.5	2	8.7	2.0	9.4	22.3	1.1	1.3	175
OHB 8.130.C-3	8.8	¾	4	3	12.2	2.2	10.1	28.3	1.4	1.5	285
OHB 8.170.C-3	8.8	¾	4	3	13.4	2.2	10.9	26.8	1.4	1.5	375
OHB 8.200.C-3	8.8	¾	5	3	13.2	2.5	11.8	28.7	1.1	1.0	440
OHB 8.250.C.3	8.8	¾	4	3	15.7	2.2	12.5	34.0	1.4	1.5	550
OHB 10.210.C-4	11	⅞	4	4	15.0	2.2	11.7	29.6	1.6	1.7	460
OHB 10.250.C-5	11	1	4	5	15.7	2.2	12.5	30.4	1.8	2.0	550
OHB 12.328.C-4	13.2	⅞	5	4	15.8	2.5	13.8	34.6	1.6	1.7	722
OHB 12,5.200.C-4	13.75	⅞	5	4	13.2	2.5	11.8	31.3	1.6	1.7	440
OHB 12,5.250.C-5	13.75	1	5	5	15.7	2.5	12.5	32.6	1.8	2.0	550
OHB 12,5.370.C-5	13.75	1	5	5	17.7	2.5	13.8	34.6	1.8	2.0	814
OHB 16.370.C-5	17.6	1	6	5	17.7	2.8	12.5	38.7	1.8	2.0	814
OHB 16.450.C-5	17.6	1	6	5	17.3	2.8	15.7	38.3	1.8	2.0	990
OHB 16.545.P-5	17.6	1	6	5	18.1	2.8	17.7	39.5	1.8	2.0	1200
OHB 20.575.P-6	22	1⅝	8	6	18.5	3.1	16.0	42.3	2.0	2.3	1265
OHB 20.725.P-6	22	1⅝	8	6	24.0	3.1	17.7	47.2	2.0	2.3	1600
OHB 20.910.P-6	22	1⅝	8	6	24.2	3.1	19.7	47.4	2.0	2.3	2000
OHB 25.725.P-7	27.5	1¼	8	7	20.1	3.1	18.1	42.4	2.4	2.6	1600
OHB 25.725.P-8	27.5	1⅝	8	8	20.1	3.1	18.1	42.4	2.4	2.6	1600
OHB 25.910.P-7	27.5	1¼	8	7	24.0	3.1	18.1	46.4	2.4	2.6	2000
OHB 25.910.P-8	27.5	1⅝	8	8	24.0	3.1	18.1	46.4	2.4	2.6	2000
OHB 32.365.P-8	35	1⅝	10	6	15.7	3.5	14.6	49.6	2.6	2.6	800
OHB 32.725.P-7	35	1¼	10	7	23.6	3.5	17.7	45.4	2.4	2.6	1600
OHB 32.910.P-9	35	1½	10	9	24.2	3.5	19.7	46.0	2.8	2.8	2000

Minimum Ultimate Strength = 4 x WLL

- The dimensions in this table are indicative only. A drawing will always be submitted prior to production and will be the leading document when discussing dimensions.
- Products shown here are standard models; inquiries for custom versions are welcome.



SEE OUR WARNING & SAFETY INFORMATION ON PAGES 136 - 149





CONSTRUCTION SPECIFIC BLOCKS

ROUND OVERHAUL BALLS

The weight of the overhaul balls in this segment are based on average boom lengths and efficiency loss in mobile and crawler cranes. The low friction and easy to access hook swivel design makes the OHB series an excellent choice for a wide variety of crane applications.

Standard features include:

- Top swivelling eye
- Design Factor of 4:1
- High quality, low friction thrust bearing

- Becket size optimized for Ropeblock Sockets such as Open Wedge (OWS), Open Spelter Sockets (OSS), Fast Connector Sockets (FCS) or Super Reeve Connector Sockets (SCS)
- Forged alloy eye hook acc. EN 1677-2
- Body made of cast material
- Robust design
- Operational temperature range: -40 up to +80°C / -40 up to +176°F
- C3M finish, signal yellow

PLEASE CONTACT YOUR SALES REPRESENTATIVE FOR MORE DETAILS



ROUND OVERHAUL BALLS

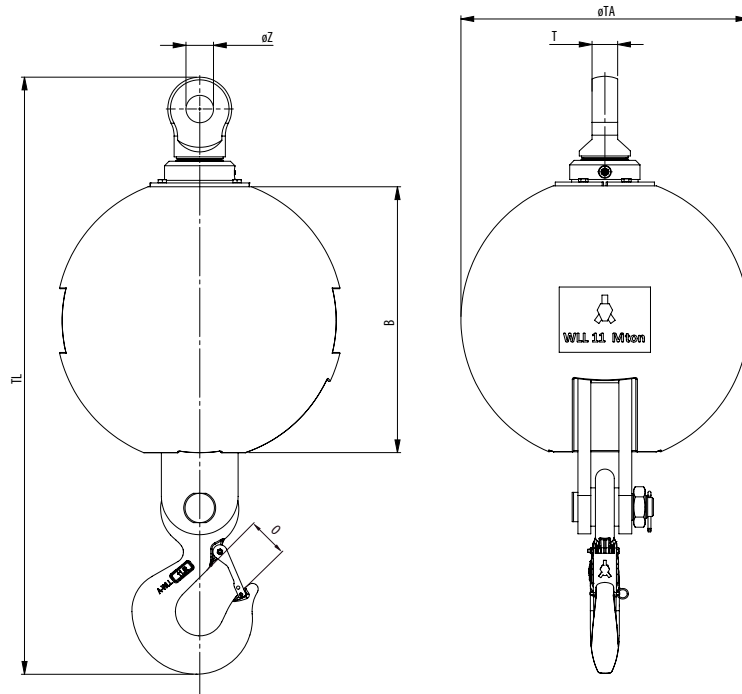

Model No.	WLL (UStons)	For wire ød (inch)	Dimensions (inch)						Weight (lbs)
			B	O	øTA	TL	T	øZ	
OHB-B 4,5.50-x	5	½ - ¾	7.8	1.7	9.1	26.2	TBD	TBD	110
OHB-B 4,5.110-x	5	½ - ¾	11.4	1.7	12.3	27.4	TBD	TBD	242
OHB-B 4,5.145-x	5	½ - ¾	12.6	1.7	13.5	28.9	TBD	TBD	320
OHB-B 7.50-x	8	½ - ¾	7.8	1.7	9.1	26.2	TBD	TBD	110
OHB-B 7.80-x	8	½ - ¾	10	1.7	11	26.2	TBD	TBD	175
OHB-B 7.110-x	8	½ - ¾	11.4	1.7	12.3	27.4	TBD	TBD	242
OHB-B 7.145-x	8	½ - ¾	12.6	1.7	13.5	28.9	TBD	TBD	320
OHB-B 11.180-x	12	¾ - 1½	13.1	2.1	14.6	33	TBD	TBD	396
OHB-B 11.265-x	12	¾ - 1½	15.4	2.1	16.7	35.9	TBD	TBD	583
OHB-B 11.320-x	12	¾ - 1½	16.4	2.1	17.7	36.9	TBD	TBD	705
OHB-B 11.530-x	12	¾ - 1½	20	2.1	21.1	40.4	TBD	TBD	1165
OHB-B 14.270-x	15	¾ - 1½	15.4	2.3	16.7	37.1	TBD	TBD	594
OHB-B 14.325-x	15	¾ - 1½	16.4	2.3	17.7	38.5	TBD	TBD	715
OHB-B 14.387-x	15	¾ - 1½	17.7	2.3	18.9	38.9	TBD	TBD	850
OHB-B 18.195-x	20	¾ - 1½	13.1	3.1	14.6	38.3	TBD	TBD	429
OHB-B 18.330-x	20	¾ - 1½	16.4	3.1	17.7	42	TBD	TBD	726
OHB-B 18.392-x	20	¾ - 1½	17.7	3.1	18.9	42.6	TBD	TBD	862
OHB-B 18.545-x	20	¾ - 1½	20	3.1	21.1	45.6	TBD	TBD	1200

x = to be replaced by becket size in final part number; TBD = these dimensions vary with wire size

Minimum Ultimate Strength = 4 x WLL

- The dimensions in this table are indicative only. A drawing will always be submitted prior to production and will be the leading document when discussing dimensions.
- Products shown here are standard models; inquiries for custom versions are welcome.



SEE OUR WARNING & SAFETY INFORMATION ON PAGES 136 - 149





OFFSHORE SPECIFIC CRANE BLOCKS

At Ropeblock we employ our Smart Engineering philosophy to design and calculate components dedicated to the offshore industry, such as special crane blocks, sheaves and swivels. Available with and without active heave compensation, these components can be used in, e.g., lattice boom cranes, knuckle boom cranes and heavy lift cranes.

Standard features include:

- Design factors in accordance with customer and third party specifications.

- Certification or classification in accordance with any IACS party or API is possible.
- 100% traceability of all load bearing parts (3.1 or 3.2).
- Fit for extremely low temperature applications.
- Can be made suitable for subsea depths up to 4000 metres.
- C5-MM or higher quality coating.
- Forged high tensile steel DIN/EN hooks.
- Lockable heavy-duty safety latch.
- Cast sheaves featuring ‘graphite lubrication’.
- High-quality, low-friction thrust bearing.
- ATEX proof on request.

PLEASE CONTACT US FOR MORE DETAILS

RECOMMENDED FINISH

Segment / application	ISO 12944 classification	Classification description	Expected protection duration	DFT (µm)
Construction	C2M	Slightly polluted atmosphere, predominately agriculture areas	5 to 15 year	120
Construction	C3M	Industrial and residential air pollution levels, with an average sulfurdioxide (IV) contamination level. Coastal areas with low salt content in air	2 to 5 year	120
Construction	C3M	Industrial and residential air pollution levels, with an average sulfurdioxide (IV) contamination level. Coastal areas with low salt content in air	5 to 15 year	160
Cargo handling	C3M	Industrial and residential air pollution levels, with an average sulfurdioxide (IV) contamination level. Coastal areas with low salt content in air	5 to 15 year	160
Cargo handling	C4H	Industrial areas and coastal areas with average salt content in air	more than 15 year	280
Cargo handling	C5-MM	Coastal areas and open sea with high salt content in air	5 to 15 year	280
Offshore	C4H	Industrial areas and coastal areas with average salt content in air	more than 15 year	300
Offshore	C5-MM	Coastal areas and open sea with high salt content in air	5 to 15 year	300
Offshore	C5-MH	Coastal areas and open sea with high salt content in air	more than 15 year	320
Offshore	NORSOK sys. 1*	Open sea with high salt content in air	more than 15 year	300





CARGO HANDLING- /MARITIME CRANE BLOCKS

The Ropeblock portfolio includes special blocks for cargo handling, especially on container ships, bulk carriers and general heavy and multi-purpose cargo ships. Our blocks are available in different classifications. Smart Engineering enables us to always come up with the optimum solution for your application and classification.

Standard features include:

- Different design factors are possible, depending on application and classification.

- Certification or classification in accordance with any IACS party is possible.
- 100% traceability of all load bearing parts (3.1 or 3.2).
- Forged high tensile steel DIN/EN hooks.
- Cast sheaves featuring ‘graphite lubrication’.
- Standard with C3M coating, higher quality finishing available.
- High-quality, low-friction thrust bearing.

PLEASE CONTACT YOUR SALES REPRESENTATIVE FOR MORE DETAILS

RECOMMENDED FINISH

Segment / application	ISO 12944 classification	Classification description	Expected protection duration	DFT (µm)
Construction	C2M	Slightly polluted atmosphere, predominately agriculture areas	5 to 15 year	120
Construction	C3M	Industrial and residential air pollution levels, with an average sulfurdioxide (IV) contamination level. Coastal areas with low salt content in air	2 to 5 year	120
Construction	C3M	Industrial and residential air pollution levels, with an average sulfurdioxide (IV) contamination level. Coastal areas with low salt content in air	5 to 15 year	160
Cargo handling	C3M	Industrial and residential air pollution levels, with an average sulfurdioxide (IV) contamination level. Coastal areas with low salt content in air	5 to 15 year	160
Cargo handling	C4H	Industrial areas and coastal areas with average salt content in air	more than 15 year	280
Cargo handling	C5-MM	Coastal areas and open sea with high salt content in air	5 to 15 year	280
Offshore	C4H	Industrial areas and coastal areas with average salt content in air	more than 15 year	300
Offshore	C5-MM	Coastal areas and open sea with high salt content in air	5 to 15 year	300
Offshore	C5-MH	Coastal areas and open sea with high salt content in air	more than 15 year	320
Offshore	NORSOK sys. 1*	Open sea with high salt content in air	more than 15 year	300





INDUSTRIAL SPECIFIC BLOCKS

This block type is always custom specific.

Depending on the particular application, the following features are available:

- Double-sealed maintenance-free roller bearings
- Compact design
- Protected grease fittings
- Durable reeve guards
- Forged high tensile steel DIN/EN hooks
- Cast sheaves, featuring graphite lubricated groove
- Motorized hook (optional)
- Temperature range depending on application
- C3M finish in signal yellow

PLEASE CONTACT YOUR SALES REPRESENTATIVE FOR MORE DETAILS





OVERHAUL WEIGHTS

University studies show that many factors are relevant to determine minimum overhaul weights.

These factors include:

- Boom length or jib height
- Geometrical design of block and crown block
- Type of bearing
- Sheave diameters
- Wire rope type and construction
- Number of stationary sheaves outside the tackle
- Grease
- Operational temperatures

The overhaul weight is therefore established in collaboration with the crane manufacturer. For cranes with various boom configurations the overhaul weight can be set by means of interchangeable cheek weights.





MISCELLANEOUS BLOCKS

Ropeblock offers a wide choice of standard blocks. Some were developed for general purposes, others for specific rigging equipment. Possible applications include routing or guiding wire rope, upending and wall tilt-up, and cargo handling on merchant vessels. The blocks presented in this catalogue are off-the-shelf products that can be modified to meet specific customer needs.

Standard features include:

- Design factor 4:1.
- D/d ration can be modified upon customer request.
- With or without becket.
- Bronze bushing.
- For high speed purposes: roller bearings.
- Painted in a suitable industrial coating.

PLEASE CONTACT US FOR MORE DETAILS

THE ANATOMY OF A ROPEBLOCK BLOCK PRODUCT NUMBER

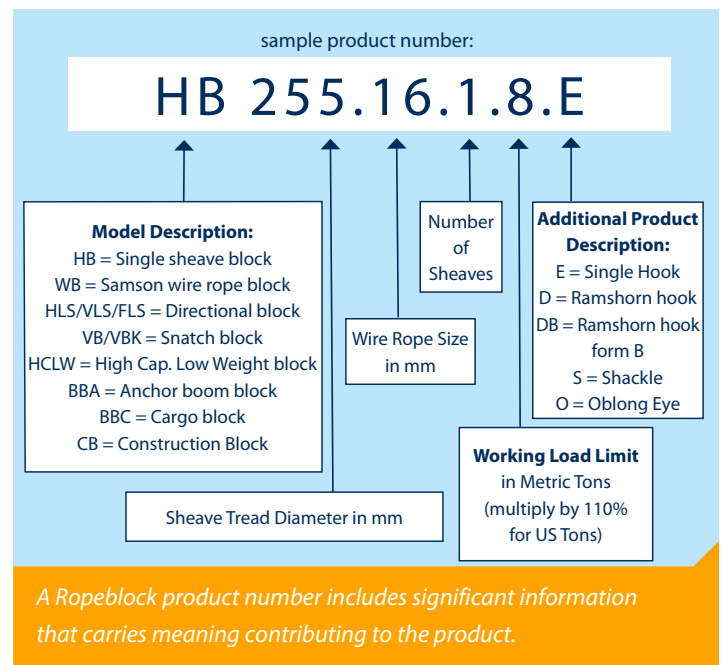

SINGLE SHEAVE BLOCKS

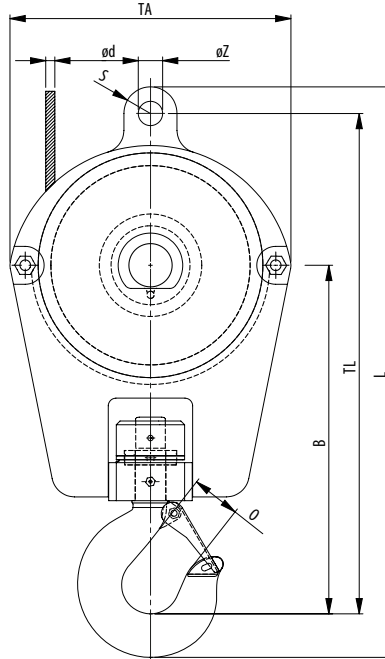

SINGLE ACTION HOOK

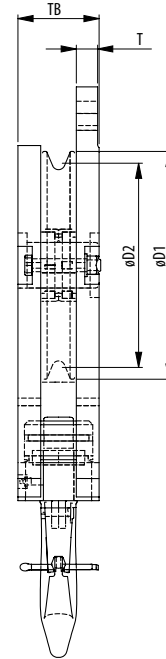

Model No.	WLL (UStons)	for wire ød (inch)	Dimensions (inch)										Weight (lbs)
			øD1	øD2	B	O	S	TA	TB	TL	T	øZ	
HB 210.11.1.5.E	5.5	7/16	9.84	8.27	13.70	1.34	1.18	12.60	4.06	20.59	0.79	1.06	90
HB 220.13.1.5.E	5.5	1/2	10.24	8.70	13.90	1.34	1.18	13.90	4.29	20.67	0.87	1.06	148
HB 220.14.1.8.E	8.8	9/16	10.24	8.58	15.35	1.69	1.38	12.99	4.76	22.48	1.10	1.26	176
HB 220.14.1.10.E	11	5/8	10.24	8.58	16.89	2.05	1.38	12.99	5.39	23.98	1.10	1.26	205
HB 255.13.1.8.E	8.8	1/2	11.81	10.04	16.77	1.69	1.18	14.57	3.98	24.45	0.87	1.06	196
HB 255.16.1.8.E	8.8	5/8	11.81	9.92	16.54	1.69	1.38	14.57	4.37	24.45	1.10	1.26	207
HB 255.16.1.10.E	11	5/8	11.81	9.92	18.07	2.05	1.38	14.57	5.00	25.94	1.10	1.26	201
HB 305.16.1.10.E	11	5/8	13.78	12.01	19.65	2.05	1.38	17.13	4.21	29.09	1.10	1.30	249
HB 345.18.1.12.E	13.2	11/16	15.75	13.58	21.93	2.24	1.77	19.69	4.92	32.76	1.38	1.46	357
HB 390.20.1.16.E	17.6	13/16	17.72	15.35	23.31	2.24	1.97	21.65	5.16	36.10	1.38	1.69	454
HB 430.22.1.20.E	22	7/8	19.69	16.93	23.31	2.99	1.97	23.62	5.83	40.63	1.57	1.69	626

Minimum Ultimate Strength = 4 x WLL

- Standard fitted with becket, cylindrical roller bearing and reeving guide.
- Standard fitted with swivel only hook (319AN style), including safety latch and split pin. Standard painted yellow (no striping).
- This crane block may be used with 2 lines only as well.
- Third party testing with certification available upon request.
- Sheaves may be adjusted for other wire rope diameters.
- Becket suitable for connecting Open Wedge Socket for indicated wire rope diameter.



SEE OUR WARNING & SAFETY INFORMATION ON PAGES 136 - 149



CONSTRUCTION BLOCK WITH SHACKLE

1 SHEAVE

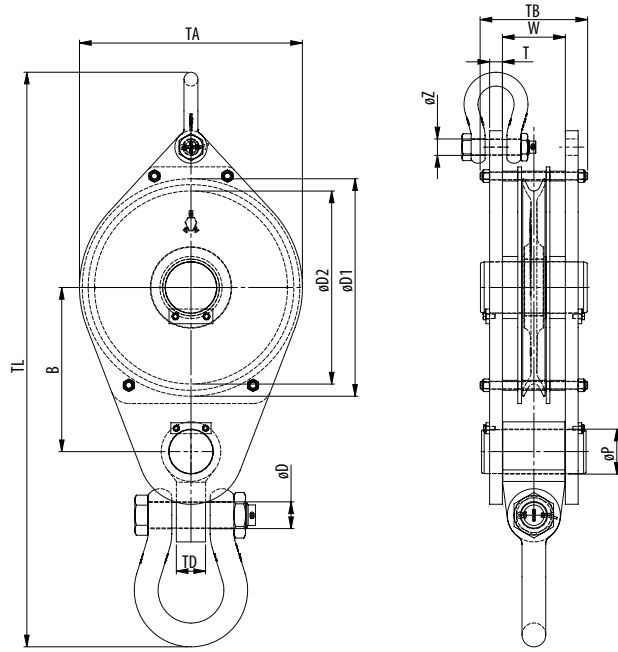

Model No.	WLL (UStons)	For wire ød (inch)	Dimensions (inch)												Weight (lbs)
			øD1	øD2	B	øD	øP	TD	øZ	T	TA	TB	TL	W	
CB 260.xx.1.18,5	20	½ - ⅝	11.8	10.2	10.1	1.8	2.4	1.4	1.1	0.8	12.2	7.5	35.3	4.2	165
CB 320.xx.1.27,5	30	⅝ - ¾	14.4	12.6	11.7	2.1	2.8	1.8	1.2	1.0	14.8	8.4	41.2	4.7	279
CB 355.xx.1.36,5	40	¾ - ⅞	16.1	14.0	13.4	2.4	3.9	2.4	1.6	1.2	16.5	9.9	48.3	5.8	452
CB 400.xx.1.45	50	¾ - 1	18.1	15.7	14.5	2.7	3.9	2.6	1.6	1.2	18.5	10.2	52.5	5.8	568
CB 450.xx.1.55	60	⅞ - 1⅛	20.3	17.7	16.1	2.9	4.7	3.1	1.8	1.4	20.9	11.6	58.7	6.8	835
CB 528.xx.1.64	70	⅞ - 1¼	23.4	20.8	17.7	2.9	4.7	3.1	1.8	1.4	24.0	11.6	61.9	6.8	1009
CB 575.xx.1.73	80	1 - 1⅞	25.6	22.6	19.4	3.4	5.5	4.3	2.1	1.6	26.4	13.3	71.2	7.8	1436
CB 630.xx.1.82	90	1 - 1½	28.0	24.8	20.6	3.4	5.5	4.3	2.1	1.6	28.7	13.3	73.6	7.8	1563

Minimum Ultimate Strength = 4 x WLL

- Standard delivered with bronze bearing
- The dimensions in this table are indicative only. A drawing will always be submitted prior production and will be the leading document when discussing dimensions.
- Blocks shown here are standard models; inquiries for custom versions are welcome.
- Refer to wire rope manufacturers D/d ratio guideline.



SEE OUR WARNING & SAFETY INFORMATION ON PAGES 136 - 149

Optional

With hanger

With pin

With swivel eye

With swivel jaw



CONSTRUCTION BLOCK WITH SHACKLE

2 SHEAVE

MISCELLANEOUS BLOCKS

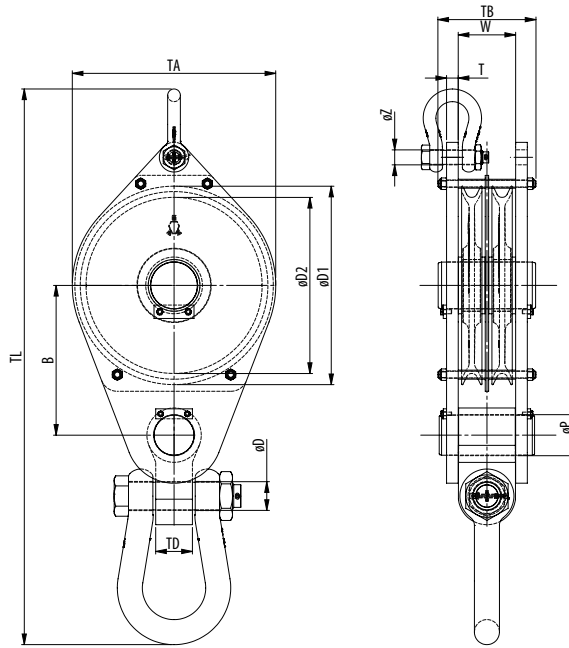

Model No.	WLL (UStons)	For wire ød (inch)	Dimensions (inch)											Weight (lbs)	
			øD1	øD2	B	øD	øP	TD	øZ	T	TA	TB	TL		W
CB 260.xx.2.27,5	30	½ - ⅝	11.8	10.2	10.1	2.1	2.4	1.8	1.1	0.8	12.2	7.5	37.3	4.2	194
CB 320.xx.2.41	45	⅝ - ¾	14.4	12.6	11.7	2.4	2.8	2.4	1.2	1.0	14.8	8.4	42.4	4.7	315
CB 355.xx.2.55	60	¾ - 7/8	16.1	14.0	13.4	2.9	3.9	3.1	1.6	1.2	16.5	9.9	52.3	5.8	520
CB 400.xx.2.68	75	¾ - 1	18.1	15.7	14.5	2.9	3.9	3.1	1.6	1.2	18.5	10.2	54.7	5.8	628
CB 450.xx.2.82	90	7/8 - 1 1/8	20.3	17.7	16.1	3.4	4.7	4.3	1.8	1.4	20.9	11.6	62.4	6.8	940
CB 528.xx.2.100	110	7/8 - 1 1/4	23.4	20.8	17.7	3.4	4.7	4.3	1.8	1.4	24.0	11.6	65.6	6.8	1130
CB 575.xx.2.114	126	1 - 1 1/16	25.6	22.6	19.4	3.9	5.5	4.7	2.1	1.6	26.4	13.3	75.9	7.8	1645
CB 630.xx.2.127	140	1 - 1 1/2	28.0	24.8	20.6	3.9	5.5	4.7	2.1	1.6	28.7	13.3	78.3	7.8	1739

Minimum Ultimate Strength = 4 x WLL

- Standard delivered with bronze bearing
- The dimensions in this table are indicative only. A drawing will always be submitted prior production and will be the leading document when discussing dimensions.
- Blocks shown here are standard models; inquiries for custom versions are welcome.
- Refer to wire rope manufacturers D/d ratio guideline.



SEE OUR WARNING & SAFETY INFORMATION ON PAGES 136 - 149



SEE OUR WARNING AND SAFETY INFORMATION ON PAGE 136



CONSTRUCTION BLOCK WITH SHACKLE

3 SHEAVE

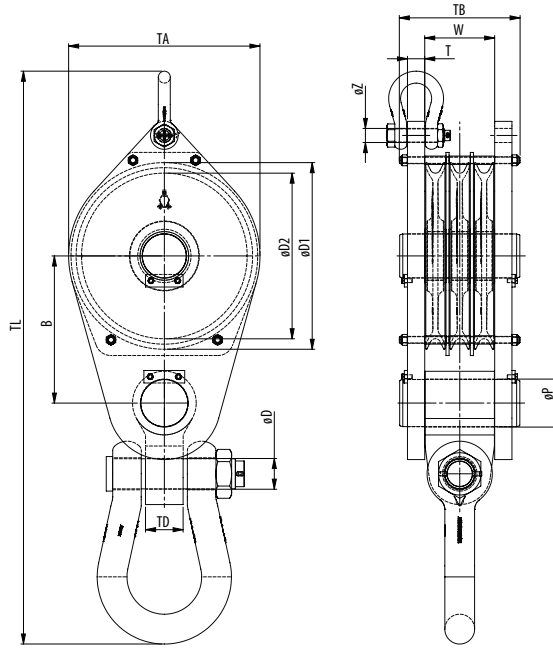

Model No.	WLL (UStons)	For wire ød (inch)	Dimensions (inch)												Weight (lbs)
			øD1	øD2	B	øD	øP	TD	øZ	T	TA	TB	TL	W	
CB 260.xx.3.36,5	40	1/2 - 5/8	11.8	10.2	10.7	2.4	3.1	2.4	1.1	1.2	12.2	9.9	39.6	5.8	298
CB 320.xx.3.55	60	3/8 - 3/4	14.4	12.6	12.5	2.9	3.9	3.1	1.2	1.4	14.8	11.3	48.0	6.8	509
CB 355.xx.3.73	80	3/4 - 7/8	16.1	14.0	14.1	3.4	5.1	4.3	1.6	1.8	16.5	13.1	57.6	7.8	825
CB 400.xx.3.91	100	3/4 - 1	18.1	15.7	15.3	3.4	5.1	4.3	1.6	1.8	18.5	13.4	59.9	7.8	988
CB 450.xx.3.110	121	7/8 - 1 1/8	20.3	17.7	16.9	3.9	5.9	4.7	1.8	2.2	20.9	15.2	68.7	8.8	1513
CB 528.xx.3.127	140	7/8 - 1 1/4	23.4	20.8	18.5	3.9	5.9	4.7	1.8	2.2	24.0	15.2	71.9	8.8	1813
CB 575.xx.3.145	160	1 - 1 1/16	25.6	22.6	20.2	4.4	6.7	5.5	2.1	2.4	26.4	17.6	79.1	10.5	2510
CB 630.xx.3.165	182	1 - 1 1/2	28.0	24.8	21.4	4.4	6.7	5.5	2.1	2.4	28.7	17.6	81.5	10.5	2656

Minimum Ultimate Strength = 4 x WLL

- Standard delivered with bronze bearing
- The dimensions in this table are indicative only. A drawing will always be submitted prior production and will be the leading document when discussing dimensions.
- Blocks shown here are standard models; inquiries for custom versions are welcome.
- Refer to wire rope manufacturers D/d ratio guideline.



SEE OUR WARNING & SAFETY INFORMATION ON PAGES 136 - 149

Optional

With hanger

With pin

With swivel eye

With swivel jaw



CONSTRUCTION BLOCK WITH SHACKLE

4 SHEAVE

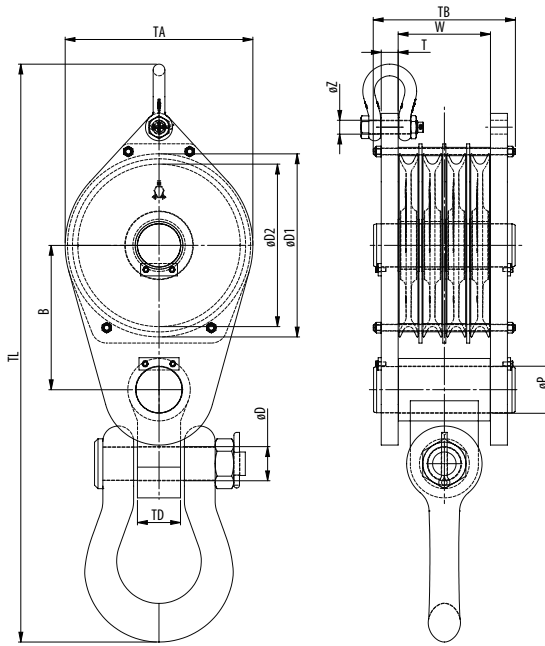

Model No.	WLL (UStons)	For wire ød (inch)	Dimensions (inch)											Weight (lbs)	
			øD1	øD2	B	øD	øP	TD	øZ	T	TA	TB	TL		W
CB 260.xx.4.41	45	1/2 - 5/8	11.8	10.2	10.7	2.4	3.1	2.4	1.1	1.2	12.2	11.9	39.6	7.8	334
CB 320.xx.4.64	70	5/8 - 3/4	14.4	12.6	12.5	2.9	3.9	3.1	1.2	1.4	14.8	12.3	48.0	7.8	554
CB 355.xx.4.82	90	3/4 - 7/8	16.1	14.0	14.1	3.4	5.1	4.3	1.6	1.8	16.5	15.7	57.6	10.5	918
CB 400.xx.4.105	116	3/4 - 1	18.1	15.7	15.3	3.4	5.1	4.3	1.6	1.8	18.5	16.1	59.9	10.5	1109
CB 450.xx.4.127	140	7/8 - 1 1/8	20.3	17.7	16.9	3.9	5.9	4.7	1.8	2.2	20.9	18.2	68.7	11.8	1690
CB 528.xx.4.150	165	7/8 - 1 1/4	23.4	20.8	18.5	4.4	5.9	5.5	1.8	2.2	24.0	18.2	73.5	11.8	2176
CB 575.xx.4.173	191	1 - 1 1/16	25.6	22.6	20.2	4.4	6.7	5.5	2.1	2.4	26.4	21.0	79.1	13.9	2809
CB 630.xx.4.191	210	1 - 1 1/2	28.0	24.8	21.4	5.2	6.7	5.5	2.1	2.4	28.7	21.0	87.4	13.9	3153

Minimum Ultimate Strength = 4 x WLL

- Standard delivered with bronze bearing
- The dimensions in this table are indicative only. A drawing will always be submitted prior production and will be the leading document when discussing dimensions.
- Blocks shown here are standard models; inquiries for custom versions are welcome.
- Refer to wire rope manufacturers D/d ratio guideline.



SEE OUR WARNING & SAFETY INFORMATION ON PAGES 136 - 149



CONSTRUCTION BLOCK WITH SHACKLE

5 SHEAVE

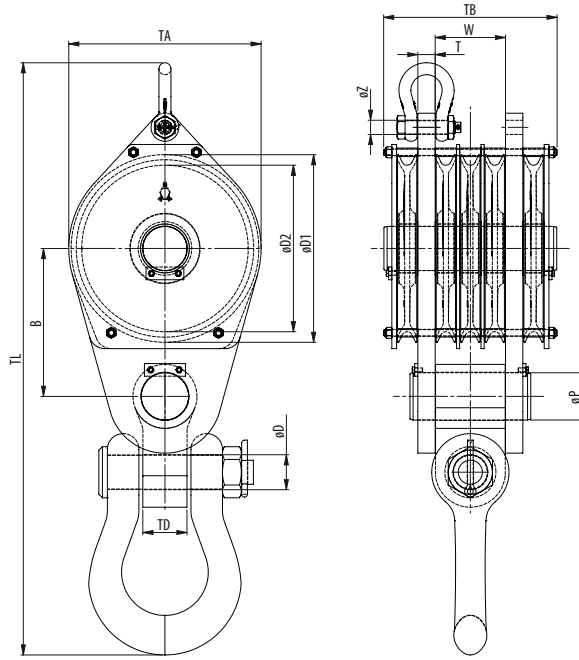

Model No.	WLL (UStons)	For wire ød (inch)	Dimensions (inch)												Weight (lbs)
			øD1	øD2	B	øD	øP	TD	øZ	T	TA	TB	TL	W	
CB 260.xx.5.50	55	1/2 - 5/8	11.8	10.2	10.7	2.7	3.1	2.6	1.1	1.2	12.2	14.8	41.4	5.8	412
CB 320.xx.5.73	80	5/8 - 3/4	14.4	12.6	12.5	3.4	3.9	4.3	1.2	1.4	14.8	16.1	51.7	6.8	713
CB 355.xx.5.95	105	3/4 - 7/8	16.1	14.0	14.1	3.4	5.1	4.3	1.6	1.8	16.5	19.0	57.6	7.8	993
CB 400.xx.5.120	132	3/4 - 1	18.1	15.7	15.3	3.9	5.1	4.7	1.6	1.8	18.5	19.3	64.7	7.8	1352
CB 450.xx.5.145	160	7/8 - 1 1/8	20.3	17.7	16.9	4.4	5.9	5.5	1.8	2.2	20.9	21.7	70.4	8.8	1971
CB 528.xx.5.173	191	7/8 - 1 1/4	23.4	20.8	18.5	4.4	5.9	5.5	1.8	2.2	24.0	21.7	73.5	8.8	2366
CB 575.xx.5.191	210	1 - 1 1/16	25.6	22.6	20.2	5.2	6.7	5.5	2.1	2.4	26.4	25.1	85.0	10.5	3267
CB 630.xx.5.220	243	1 - 1 1/2	28.0	24.8	21.4	5.2	6.7	5.5	2.1	2.4	28.7	25.1	87.4	10.5	3403

Minimum Ultimate Strength = 4 x WLL

- Standard delivered with bronze bearing
- The dimensions in this table are indicative only. A drawing will always be submitted prior production and will be the leading document when discussing dimensions.
- Blocks shown here are standard models; inquiries for custom versions are welcome.
- Refer to wire rope manufacturers D/d ratio guideline.



SEE OUR WARNING & SAFETY INFORMATION ON PAGES 136 - 149

Optional

With hanger

With pin

With swivel eye

With swivel jaw



CONSTRUCTION BLOCK WITH SHACKLE

6 SHEAVE

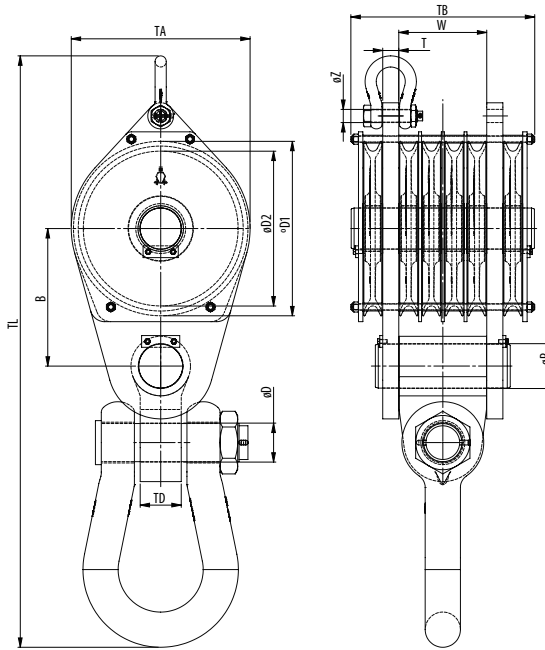

Model No.	WLL (UStons)	For wire ød (inch)	Dimensions (inch)												Weight (lbs)
			øD1	øD2	B	øD	øP	TD	øZ	T	TA	TB	TL	W	
CB 260.xx.6.55	60	1/2 - 5/8	11.8	10.2	10.7	2.9	3.1	3.1	1.1	1.2	12.2	16.7	43.6	7.8	481
CB 320.xx.6.82	90	5/8 - 3/4	14.4	12.6	12.5	3.4	3.9	4.3	1.2	1.4	14.8	17.1	51.7	7.8	758
CB 355.xx.6.110	121	3/4 - 7/8	16.1	14.0	14.1	3.9	5.1	4.7	1.6	1.8	16.5	21.7	62.3	10.5	1215
CB 400.xx.6.132	146	3/4 - 1	18.1	15.7	15.3	3.9	5.1	4.7	1.6	1.8	18.5	22.0	64.7	10.5	1472
CB 450.xx.6.160	176	7/8 - 1 1/8	20.3	17.7	16.9	4.4	5.9	5.5	1.8	2.2	20.9	24.7	70.4	11.8	2147
CB 528.xx.6.191	211	7/8 - 1 1/4	23.4	20.8	18.5	5.2	5.9	5.5	1.8	2.2	24.0	24.7	79.4	11.8	2792
CB 575.xx.6.220	243	1 - 1 1/16	25.6	22.6	20.2	5.2	6.7	5.5	2.1	2.4	26.4	28.5	85.0	13.9	3566
CB 630.xx.6.240	265	1 - 1 1/2	28.0	24.8	21.4	5.6	6.7	5.9	2.1	2.4	28.7	28.5	90.0	13.9	3837

Minimum Ultimate Strength = 4 x WLL

- Standard delivered with bronze bearing
- The dimensions in this table are indicative only. A drawing will always be submitted prior production and will be the leading document when discussing dimensions.
- Blocks shown here are standard models; inquiries for custom versions are welcome.
- Refer to wire rope manufacturers D/d ratio guideline.



SEE OUR WARNING & SAFETY INFORMATION ON PAGES 136 - 149



SAMSON WIRE ROPE BLOCKS

1 SHEAVE

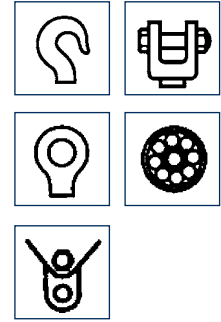
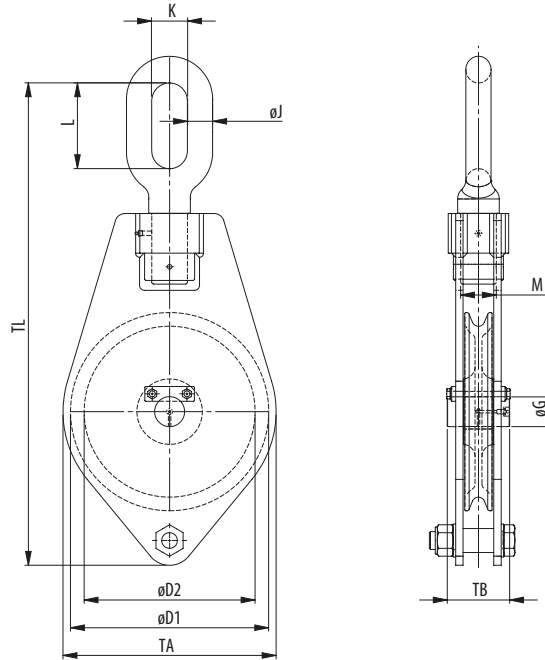

- Hook
- Jaw
- Stud eye
- Roller bearings
- Becket

Model No. (+B for w. becket)	WLL (UStons)	for wire ød (inch)	Dimensions (inch)										Weight (lbs)
			øD1	øD2	øG	øJ	K	L	M	TA	TB	TL	
WB 80.8.1.0.75.O	0.8	5/16	3.94	3.15	0.59	0.47	0.83	1.89	0.63	4.33	1.77	10.83	4
WB 105.10.1.1.1.O	1.1	3/8	4.92	4.13	0.87	0.63	1.02	2.28	0.71	5.31	2.05	13.23	7
WB 120.12.1.2.0	2.2	1/2	5.91	4.72	1.18	0.63	1.02	2.28	0.94	6.69	2.91	16.02	13
WB 165.14.1.3.0	3.3	5/16	7.87	6.50	1.18	0.83	1.26	2.83	1.18	8.66	2.91	19.69	22
WB 210.18.1.4.0	4.4	11/16	9.84	8.27	1.38	1.02	1.57	3.70	1.30	10.63	3.19	23.94	40
WB 255.20.1.6.0	6.6	13/16	11.81	10.04	1.57	1.14	1.77	4.25	1.65	12.60	3.46	27.80	60
WB 305.22.1.8.0	8.8	7/8	13.78	12.01	1.77	1.26	1.93	4.49	1.77	14.96	3.62	30.63	97
WB 305.22.1.10.O	11.0	7/8	13.78	12.01	1.97	1.42	2.13	4.92	2.05	14.96	4.33	31.30	110
WB 345.24.1.10.O	11.0	15/16	15.75	13.58	1.97	1.42	2.13	4.92	2.05	16.93	4.33	33.39	132
WB 305.22.1.12.O	13.2	7/8	13.78	12.01	1.97	1.61	2.36	5.67	2.20	14.96	4.49	32.32	130
WB 345.24.1.12.O	13.2	15/16	15.75	13.58	2.36	1.61	2.36	5.67	2.20	16.93	4.65	36.46	165
WB 305.22.1.16.O	17.6	7/8	13.78	12.01	1.97	1.81	2.60	6.42	2.52	14.96	4.49	34.61	152
WB 345.24.1.16.O	17.6	15/16	15.75	13.58	2.36	1.81	2.60	6.42	2.52	16.93	4.65	37.76	179
WB 345.24.1.20.O	22.0	15/16	15.75	13.58	2.36	2.01	2.83	6.81	2.83	16.93	4.65	38.98	214
WB 390.28.1.20.O	22.0	1 1/8	17.72	15.35	2.76	2.01	2.83	6.81	2.83	18.90	5.04	41.18	240
WB 390.28.1.25.O	27.6	1 1/8	17.72	15.35	2.76	2.36	3.15	7.68	2.99	18.90	5.04	43.50	287
WB 390.28.1.30.O	33.1	1 1/8	17.72	15.35	2.76	2.36	3.54	8.66	3.15	18.90	5.28	45.08	331

Minimum Ultimate Strength = 5 x WLL

WLL= Working Load Limit on head fitting.

- All blocks up to 30 tons are standard supplied with swivel oval eye, for over 30 tons with swivel stud eye.
- All blocks can be supplied with swivel hook, swivel stud eye or swivel jaw.
- Standard supplied with bronze bearings.
- Other bearings available on request.
- Groove in sheave may be adjusted to other wire rope diameters.



SEE OUR WARNING & SAFETY
INFORMATION ON PAGES 136 - 149



SAMSON WIRE ROPE BLOCKS

2 SHEAVES

BLOCKS

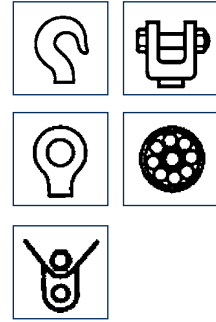
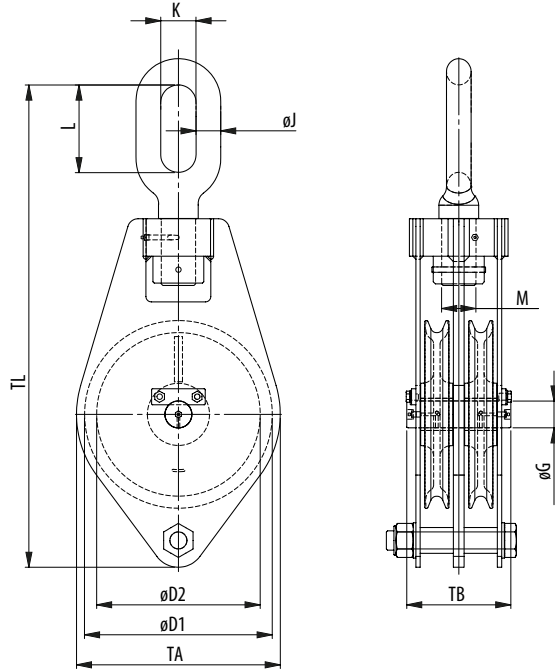

- Hook
- Jaw
- Stud eye
- Roller bearings
- Becket

Model No. (+B for w. becket)	WLL (UStons)	for wire ød (inch)	Dimensions (inch)										Weight (lbs)
			øD1	øD2	øG	øJ	K	L	M	TA	TB	TL	
WB 80.8.2.1.O	1.1	5/16	3.94	3.15	0.59	0.63	1.02	2.28	0.71	4.33	2.76	11.61	9
WB 105.10.2.1,5.O	1.7	3/8	4.92	4.13	0.87	0.63	1.02	2.28	0.94	5.31	3.35	13.23	13
WB 120.12.2.3.O	3.3	1/2	5.91	4.72	1.18	0.83	1.26	2.83	1.18	6.69	4.72	16.93	24
WB 165.14.2.4.O	4.4	5/16	7.87	6.50	1.18	1.02	1.57	3.70	1.30	8.66	4.72	21.18	40
WB 210.18.2.6.O	6.6	11/16	9.84	8.27	1.38	1.14	1.77	4.25	1.65	10.63	5.24	24.57	71
WB 255.20.2.8.O	8.8	13/16	11.81	10.04	1.57	1.26	1.93	4.49	1.77	12.60	5.75	28.07	95
WB 305.22.2.10.O	11.0	7/8	13.78	12.01	1.77	1.42	2.13	4.92	2.05	14.96	5.98	22.40	163
WB 305.22.2.12.O	13.2	7/8	13.78	12.01	1.97	1.61	2.36	5.67	2.20	14.96	7.32	32.32	179
WB 345.24.2.12.O	13.2	15/16	15.75	13.58	1.97	1.61	2.36	5.67	2.20	16.93	7.09	35.16	225
WB 305.22.2.16.O	17.6	7/8	13.78	12.01	1.97	1.81	2.60	6.42	2.52	14.96	7.32	34.61	216
WB 345.24.2.16.O	17.6	15/16	15.75	13.58	2.36	1.81	2.60	6.42	2.52	16.93	7.56	37.76	278
WB 305.22.2.20.O	22.0	7/8	13.78	12.01	1.97	2.01	2.83	6.81	2.83	14.96	7.32	35.28	256
WB 345.24.2.20.O	22.0	15/16	15.75	13.58	2.36	2.01	2.83	6.81	2.83	16.93	7.56	38.43	322
WB 345.24.2.25.O	27.6	15/16	15.75	13.58	2.36	2.36	3.15	7.68	2.99	16.93	7.56	41.93	373
WB 390.28.2.25.O	27.6	1 1/8	17.72	15.35	2.76	2.36	3.15	7.68	2.99	18.90	8.70	44.09	419
WB 345.24.2.30.O	33.1	15/16	15.75	13.58	2.36	2.36	3.54	8.66	3.15	16.93	7.56	43.11	406
WB 390.28.2.30.O	33.1	1 1/8	17.72	15.35	2.76	2.36	3.54	8.66	3.15	18.90	9.29	45.28	450
WB 390.28.2.40.O	44.1	1 1/8	17.72	15.35	2.76	-	3.78	3.78	3.54	18.90	9.29	40.55	496

Minimum Ultimate Strength = 5 x WLL

WLL= Working Load Limit on head fitting.

- All blocks up to 30 tons are standard supplied with swivel oval eye, for over 30 tons with swivel stud eye.
- All blocks can be supplied with swivel hook, swivel stud eye or swivel jaw.
- Standard supplied with bronze bearings.
- Other bearings available on request.
- Groove in sheave may be adjusted to other wire rope diameters.



SEE OUR WARNING & SAFETY INFORMATION ON PAGES 136 - 149

SEE OUR WARNING AND SAFETY INFORMATION ON PAGE 136



SAMSON WIRE ROPE BLOCKS

3 SHEAVES

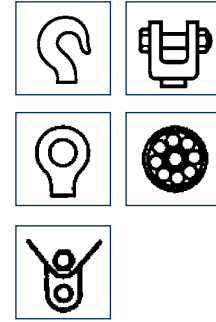
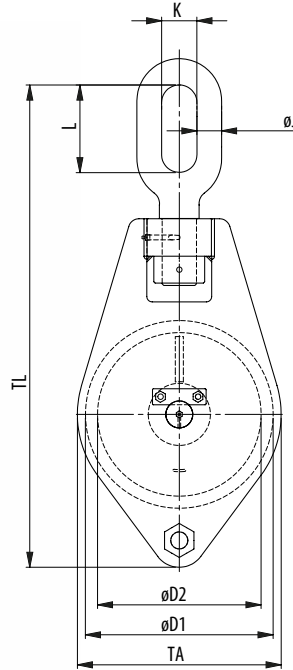

- Hook
- Jaw
- Stud eye
- Roller bearings
- Becket

Model No. (+B for w. becket)	WLL (UStons)	for wire ød (inch)	Dimensions (inch)										Weight (lbs)
			øD1	øD2	G	øJ	K	L	M	TA	TB	TL	
WB 105.10.3.2.O	2.2	3/8	4.92	4.13	0.87	0.63	1.02	2.28	0.94	5.31	4.72	13.23	20
WB 120.12.3.4.O	4.4	1/2	5.91	4.72	1.18	1.02	1.57	3.70	1.30	6.69	6.54	18.43	37
WB 165.14.3.6.O	6.6	5/16	7.87	6.50	1.18	1.14	1.77	4.25	1.65	8.66	6.54	21.89	62
WB 210.18.3.8.O	8.8	1 1/16	9.84	8.27	1.38	1.26	1.93	4.49	1.77	10.63	7.28	24.92	101
WB 255.20.3.10.O	11.0	1 3/16	11.81	10.04	1.57	1.42	2.13	4.92	2.05	12.60	8.03	28.86	152
WB 305.22.3.12.O	13.2	7/8	13.78	12.01	1.77	1.61	2.36	5.67	2.20	14.96	8.35	32.40	218
WB 305.24.3.16.O	17.6	1 5/16	13.78	12.01	1.97	1.81	2.60	6.42	2.52	14.96	10.16	34.65	265
WB 345.24.3.16.O	17.6	1 5/16	15.75	13.58	1.97	1.81	2.60	6.42	2.52	16.93	9.84	36.50	346
WB 305.24.3.20.O	22.0	1 5/16	13.78	12.01	1.97	2.01	2.83	6.81	2.83	14.96	10.16	35.28	315
WB 345.24.3.20.O	22.0	1 5/16	15.75	13.58	2.36	2.01	2.83	6.81	2.83	16.93	10.47	39.61	406
WB 305.24.3.25.O	27.6	1 5/16	13.78	12.01	1.97	2.36	3.15	7.68	2.99	14.96	10.47	37.60	375
WB 345.24.3.25.O	27.6	1 5/16	15.75	13.58	2.36	2.36	3.15	7.68	2.99	16.93	10.47	41.93	437
WB 390.28.3.25.O	27.6	1 1/8	17.72	15.35	2.76	2.36	3.15	7.68	2.99	18.90	11.65	44.09	485
WB 345.28.3.30.O	33.1	1 1/8	15.75	13.58	2.36	2.36	3.54	8.66	3.15	16.93	10.47	43.11	474
WB 390.28.3.30.O	33.1	1 1/8	17.72	15.35	2.76	2.36	3.54	8.66	3.15	18.90	11.65	44.88	562
WB 345.28.3.40.O	44.1	1 1/8	15.75	13.58	2.36	-	3.78	3.78	3.54	16.93	10.94	37.20	551
WB 390.28.3.40.O	44.1	1 1/8	17.72	15.35	2.76	-	3.78	3.78	3.54	18.90	12.13	40.55	650
WB 390.28.3.50.O	55.1	1 1/8	17.72	15.35	2.95	-	4.17	4.17	3.94	18.90	13.31	41.54	739

Minimum Ultimate Strength = 5 x WLL

WLL= Working Load Limit on head fitting.

- All blocks up to 30 tons are standard supplied with swivel oval eye, for over 30 tons with swivel stud eye.
- All blocks can be supplied with swivel hook, swivel stud eye or swivel jaw.
- Standard supplied with bronze bearings.
- Other bearings available on request.
- Groove in sheave may be adjusted to other wire rope diameters.



SEE OUR WARNING & SAFETY INFORMATION ON PAGES 136 - 149



HORIZONTAL DIRECTIONAL BLOCKS

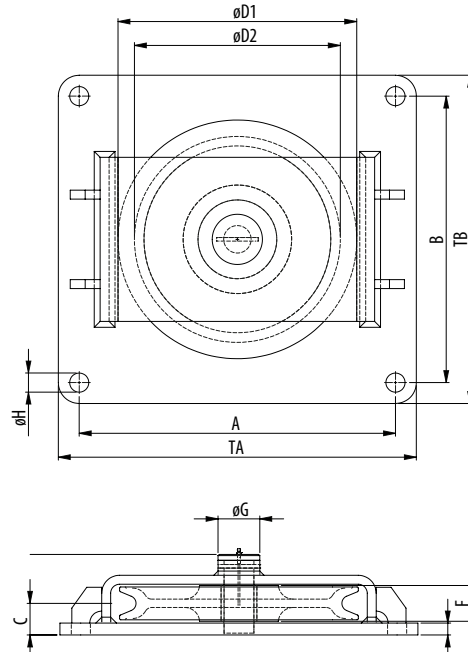

BRONZE BUSHING

Model No.	WLL (UStons)	Wire size up to (inch)	Bearing	Dimensions (inch)											Weight (lbs)	
				$\phi D1$	$\phi D2$	A	B	C	F	ϕG	ϕH	T	TA	TB		TC
HLS 105.10.1.1-BR	1.1	3/8	Bronze	4.92	4.13	7.09	5.91	0.89	1.06	0.87	0.35	0.31	7.87	6.69	2.13	5
HLS 120.12.1.2-BR	2.2	1/2	Bronze	5.91	4.72	8.66	7.48	1.22	1.57	1.18	0.43	0.39	9.84	8.66	2.83	10
HLS 165.14.1.3-BR	3.3	5/16	Bronze	7.87	6.50	11.42	9.45	1.30	1.57	1.18	0.53	0.47	12.60	10.63	2.99	17
HLS 210.18.1.4-BR	4.4	11/16	Bronze	9.84	8.27	14.17	12.20	1.52	1.77	1.38	0.69	0.59	15.75	13.78	3.39	32
HLS 255.20.1.6-BR	6.6	13/16	Bronze	11.81	10.04	15.75	14.17	1.81	1.97	1.57	0.87	0.79	17.72	16.14	3.90	50
HLS 305.22.1.8-BR	8.8	7/8	Bronze	13.78	12.01	18.11	16.54	1.81	1.97	1.77	1.02	0.79	20.47	18.90	3.90	70
HLS 345.24.1.10-BR	11.0	15/16	Bronze	15.75	13.58	20.87	18.90	2.01	2.36	1.97	1.26	0.79	23.62	21.65	4.45	100

Minimum Ultimate Strength = 4 x WLL

BALL OR CYLINDRICAL ROLLER BEARING

Model No.	WLL (UStons)	Wire size up to (inch)	Bearing	Dimensions (inch)											Weight (lbs)	
				$\phi D1$	$\phi D2$	A	B	C	F	ϕG	ϕH	T	TA	TB		TC
HLS 105.10.1.1-BR	1.1	3/8	2 x Ball	4.92	4.13	7.09	5.91	0.89	1.06	0.87	0.35	0.31	7.87	6.69	2.13	5
HLS 120.12.1.2-BR	2.2	1/2	2 x Ball	5.91	4.72	8.66	7.48	1.22	1.57	1.18	0.43	0.39	9.84	8.66	2.83	10
HLS 165.14.1.3-BR	3.3	5/16	2 x Ball	7.87	6.50	11.42	9.45	1.30	1.57	1.18	0.53	0.47	12.60	10.63	2.99	17
HLS 210.18.1.4-BR	4.4	11/16	Straight	9.84	8.27	14.17	12.20	1.52	1.77	1.38	0.69	0.59	15.75	13.78	3.39	32
HLS 255.20.1.6-BR	6.6	13/16	Straight	11.81	10.04	15.75	14.17	1.81	1.97	1.57	0.87	0.79	17.72	16.14	3.90	50
HLS 305.22.1.8-BR	8.8	7/8	Straight	13.78	12.01	18.11	16.54	1.81	1.97	1.77	1.02	0.79	20.47	18.90	3.90	70
HLS 345.24.1.10-BR	11.0	15/16	Straight	15.75	13.58	20.87	18.90	2.01	2.36	1.97	1.26	0.79	23.62	21.65	4.45	100

Minimum Ultimate Strength = 4 x WLL

WLL= Working Load Limit on head fitting.

- The indicated WLL is valid at 180° wrap.
The FoS may decrease in other loading conditions.



SEE OUR WARNING & SAFETY INFORMATION ON PAGES 136 - 149



VERTICAL DIRECTIONAL BLOCKS

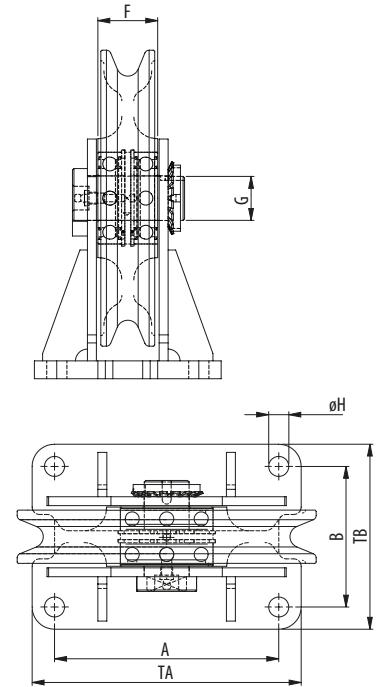
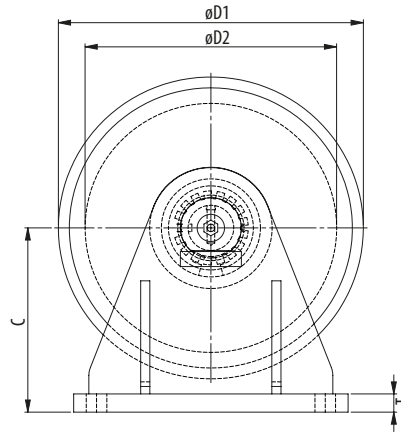

BRONZE BUSHING

Model No.	WLL (UStons)	for wire ϕd (inch)	Bearing	Dimensions (inch)										Weight (lbs)	
				$\phi D1$	$\phi D2$	A	B	C	F	G	ϕH	T	TA		TB
VLS 105.10.1.1-BR	1.1	$\frac{3}{8}$	Bronze	4.92	4.13	3.54	2.76	3.27	1.06	0.87	0.35	0.31	4.53	3.74	3
VLS 120.12.1.2-BR	2.2	$\frac{1}{2}$	Bronze	5.91	4.72	4.53	3.35	3.74	1.57	1.18	0.43	0.39	5.51	4.33	5
VLS 165.14.1.3-BR	3.3	$\frac{5}{16}$	Bronze	7.87	6.50	5.91	3.74	4.80	1.57	1.18	0.53	0.47	7.09	4.92	8
VLS 210.18.1.4-BR	4.4	$\frac{11}{16}$	Bronze	9.84	8.27	7.48	4.72	6.10	1.77	1.38	0.69	0.59	9.06	6.30	17
VLS 255.20.1.6-BR	6.6	$\frac{13}{16}$	Bronze	11.81	10.04	8.66	5.91	7.28	1.97	1.57	0.87	0.79	10.63	7.87	26
VLS 305.22.1.8-BR	8.8	$\frac{7}{8}$	Bronze	13.78	12.01	10.63	6.30	8.66	1.97	1.77	1.02	0.98	12.99	8.66	41
VLS 345.24.1.10-BR	11.0	$\frac{15}{16}$	Bronze	15.75	13.58	11.81	7.48	10.04	2.36	1.97	1.26	1.18	14.57	10.24	64

Minimum Ultimate Strength = 4 x WLL

BALL OR CYLINDRICAL ROLLER BEARING

Model No.	WLL (UStons)	for wire ϕd (inch)	Bearing	Dimensions (inch)										Weight (lbs)	
				$\phi D1$	$\phi D2$	A	B	C	F	G	ϕH	T	TA		TB
VLS 105.10.1.1	1.1	$\frac{3}{8}$	2 x Ball	4.92	4.13	3.54	2.76	3.27	1.06	0.87	0.35	0.31	4.53	3.74	7
VLS 120.12.1.2	2.2	$\frac{1}{2}$	2 x Ball	5.91	4.72	4.53	3.35	3.74	1.57	1.18	0.43	0.39	5.51	4.33	11
VLS 165.14.1.3	3.3	$\frac{5}{16}$	2 x Ball	7.87	6.50	5.91	3.74	4.80	1.57	1.18	0.53	0.47	7.09	4.92	18
VLS 210.18.1.4	4.4	$\frac{11}{16}$	Straight	9.84	8.27	7.48	4.72	6.10	1.77	1.38	0.69	0.59	9.06	6.30	37
VLS 255.20.1.6	6.6	$\frac{13}{16}$	Straight	11.81	10.04	8.66	5.91	7.28	1.97	1.57	0.87	0.79	10.63	7.87	57
VLS 305.22.1.8	8.8	$\frac{7}{8}$	Straight	13.78	12.01	10.63	6.30	8.66	1.97	1.77	1.02	0.98	12.99	8.66	90
VLS 345.24.1.10	11.0	$\frac{15}{16}$	Straight	15.75	13.58	11.81	7.48	10.04	2.36	1.97	1.26	1.18	14.57	10.24	141

Minimum Ultimate Strength = 4 x WLL

WLL= Working Load Limit on head fitting.

- The indicated WLL is valid at 180° wrap. The FoS may decrease in other loading conditions.

 SEE OUR WARNING & SAFETY INFORMATION ON PAGES 136 - 148



FLAG DIRECTIONAL BLOCKS

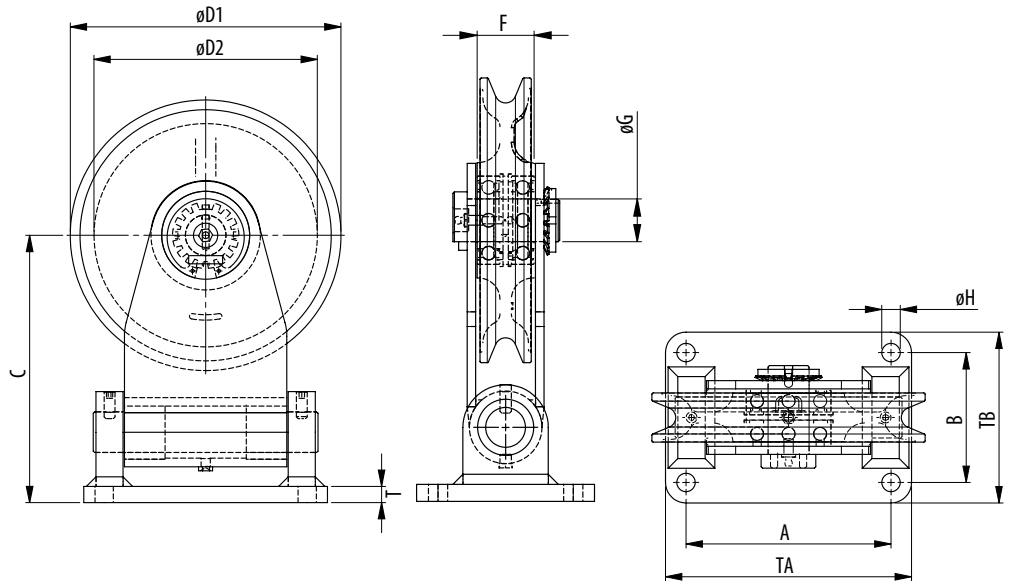

BRONZE BUSHING

Model No.	WLL (UStons)	for wire ϕd (inch)	Bearing	Dimensions (inch)										Weight (lbs)	
				$\phi D1$	$\phi D2$	A	B	C	F	G	ϕH	T	TA		TB
FLS 105.10.1.1-BR	1.1	$\frac{3}{8}$	Bronze	4.92	4.13	3.54	2.76	3.27	1.06	0.87	0.35	0.31	4.53	3.74	8
FLS 120.12.1.2-BR	2.2	$\frac{1}{2}$	Bronze	5.91	4.72	4.53	3.35	3.74	1.57	1.18	0.43	0.39	5.51	4.33	14
FLS 165.14.1.3-BR	3.3	$\frac{5}{16}$	Bronze	7.87	6.50	5.91	3.74	4.80	1.57	1.18	0.53	0.47	7.09	4.92	24
FLS 210.18.1.4-BR	4.4	$\frac{11}{16}$	Bronze	9.84	8.27	7.48	4.72	6.10	1.77	1.38	0.69	0.59	9.06	6.30	46
FLS 255.20.1.6-BR	6.6	$\frac{13}{16}$	Bronze	11.81	10.04	8.66	5.91	7.28	1.97	1.57	0.87	0.79	10.63	7.87	73
FLS 305.22.1.8-BR	8.8	$\frac{7}{8}$	Bronze	13.78	12.01	10.63	6.30	8.66	1.97	1.77	1.02	0.98	12.99	8.66	115
FLS 345.24.1.10-BR	11.0	$\frac{15}{16}$	Bronze	15.75	13.58	11.81	7.48	10.04	2.36	1.97	1.26	1.18	14.57	10.24	176

Minimum Ultimate Strength = 4 x WLL

BALL OR CYLINDRICAL ROLLER BEARING

Model No.	WLL (UStons)	for wire ϕd (inch)	Bearing	Dimensions (inch)										Weight (lbs)	
				$\phi D1$	$\phi D2$	A	B	C	F	G	ϕH	T	TA		TB
FLS 105.10.1.1	1.1	$\frac{3}{8}$	2 x Ball	4.92	4.13	3.54	2.76	3.27	1.06	0.87	0.35	0.31	4.53	3.74	8
FLS 120.12.1.2	2.2	$\frac{1}{2}$	2 x Ball	5.91	4.72	4.53	3.35	3.74	1.57	1.18	0.43	0.39	5.51	4.33	14
FLS 165.14.1.3	3.3	$\frac{5}{16}$	2 x Ball	7.87	6.50	5.91	3.74	4.80	1.57	1.18	0.53	0.47	7.09	4.92	24
FLS 210.18.1.4	4.4	$\frac{11}{16}$	Straight	9.84	8.27	7.48	4.72	6.10	1.77	1.38	0.69	0.59	9.06	6.30	46
FLS 255.20.1.6	6.6	$\frac{13}{16}$	Straight	11.81	10.04	8.66	5.91	7.28	1.97	1.57	0.87	0.79	10.63	7.87	73
FLS 305.22.1.8	8.8	$\frac{7}{8}$	Straight	13.78	12.01	10.63	6.30	8.66	1.97	1.77	1.02	0.98	12.99	8.66	115
FLS 345.24.1.10	11.0	$\frac{15}{16}$	Straight	15.75	13.58	11.81	7.48	10.04	2.36	1.97	1.26	1.18	14.57	10.24	176

Minimum Ultimate Strength = 4 x WLL

WLL= Working Load Limit on head fitting.

- The indicated WLL is valid at 180° wrap and 0° swing. The FoS may decrease in other loading conditions.



SEE OUR WARNING & SAFETY INFORMATION ON PAGES 136 - 148



SNATCH BLOCKS >>

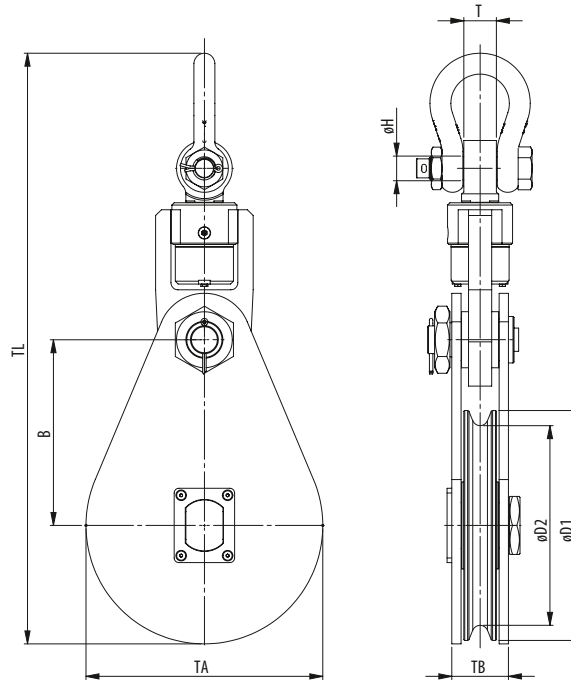

- Hook
- Clevis
- Tailboard
- Oblong eye

Model No.	WLL (UStons)	For wire ød (inch)	Dimensions (inch)								Weight (lbs)
			øD1	øD2	B	øH	T	TA	TB	TC/TL	
VB 355.22.1.14.S	15	7/8	16.1	14	13	1.4	1.9	16.6	3.6	35	190
VB 240.28.1.20.S	22	1 - 1 1/8	11.8	9.4	10	1.5	1.9	12.2	3.3	28.9	120
VB 300.32.1.20.S	22	1 1/8 - 1 1/4	14.4	11.8	11.3	1.5	1.9	14.8	3.3	31.4	130
VB 240.28.1.25.S	27.5	1 - 1 1/8	11.8	9.4	10	1.6	2.1	12.2	3.3	28.6	125
VB 300.32.1.25.S	27.5	1 1/8 - 1 1/4	14.4	11.8	11.3	1.6	2.1	14.8	3.3	31.2	140
VB 390.26.1.25.S	27.5	7/8 - 1	17.7	15.4	13.8	2.1	2.8	16.1	4.4	39.5	265
VB 240.28.1.27.S	30	1 - 1 1/8	11.8	9.4	10	1.7	2.2	12.2	3.3	32	150
VB 300.32.1.27.S	30	1 1/8 - 1 1/4	14.4	11.8	11.3	1.7	2.2	14.8	3.3	34.6	185
VB 345.32.1.32.S	35	1 1/8 - 1 1/4	15.7	13.6	12.8	2.1	2.8	16.1	4.4	37.4	265
VB 345.36.1.32.S	35	1 1/4 - 1 3/8	15.7	13.6	12.8	2.1	2.8	16.1	4.4	37.4	265
VB 390.32.1.32.S	35	1 1/8 - 1 1/4	17.7	15.4	13.8	2.1	2.8	18.5	4.4	39.5	310
VB 390.38.1.32.S	35	1 3/8 - 1 1/2	17.7	15.4	13.8	2.1	2.8	18.5	4.4	39.5	310
VB 430.32.1.32.S	35	1 1/8 - 1 1/4	19.5	16.9	14.8	2.1	2.8	20.1	4.4	41.3	330
VB 430.38.1.32.S	35	1 3/8 - 1 1/2	19.5	16.9	14.8	2.1	2.8	20.1	4.4	41.3	330
VB 520.32.1.32.S	35	1 1/8 - 1 1/4	23.4	20.5	17.1	2.1	2.8	24	4.4	45.6	660
VB 430.32.1.36,5.S	40	1 1/8 - 1 1/4	19.5	16.9	15.7	2.1	2.8	20.1	4.8	42.7	440
VB 430.38.1.36,5.S	40	1 3/8 - 1 1/2	19.5	16.9	15.7	2.1	2.8	20.1	4.8	42.7	440

Minimum Ultimate Strength = 4 x WLL

WLL = Working Load Limit on head fitting.

- The dimensions in this table are indicative only. A drawing will always be submitted prior to production and will be the leading document when discussing dimensions.
- Blocks shown here are standard models; inquiries for custom versions are welcome.
- Refer to wire rope manufacturers D/d ratio guideline.
- Standard provided with bronze bearing. Roller bearing optional.



SEE OUR WARNING & SAFETY INFORMATION ON PAGES 136 - 149



<< SNATCH BLOCKS

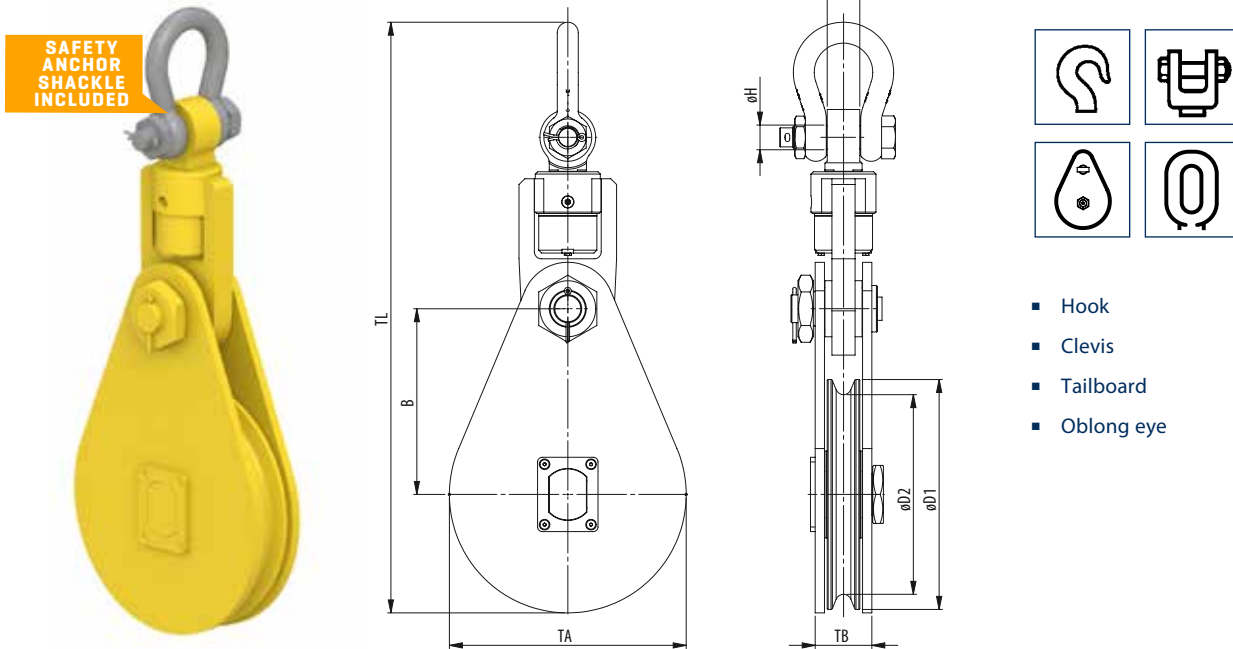

Model No.	WLL (UStons)	For wire ød (inch)	Dimensions (inch)								Weight (lbs)
			øD1	øD2	B	øH	T	TA	TB	TC/TL	
VB 430.38.1.46.S	50	1 3/8 - 1 1/2	19.5	16.9	15.8	2.1	2.8	20.1	4.8	43.2	440
VB 520.38.1.46.S	50	1 3/8 - 1 1/2	23.4	20.5	18.1	2.1	2.8	24	4.8	47.5	550
VB 520.44.1.46.S	50	1 1/2 - 1 3/4	23.4	20.5	18.1	2.1	2.8	24	4.8	47.5	550
VB 240.28.1.55.S	60	1 - 1 1/8	11.8	9.4	11.4	2.3	3.1	12.2	5.6	37.8	383
VB 520.38.1.55.S	60	1 3/8 - 1 1/2	23.4	20.5	18.1	2.3	3.1	24	5.6	50.4	680
VB 520.44.1.55.S	60	1 1/2 - 1 3/4	23.4	20.5	18.1	2.3	3.1	24	5.6	50.4	680
VB 520.52.1.55.S	60	1 3/4 - 2	23.4	20.5	18.1	2.3	3.1	24	5.6	50.4	680
VB 520.52.1.75.S	82.5	1 3/4 - 2	23.4	20.5	18.1	2.9	3.9	24	5.6	52.6	726
VB 630.58.1.75.S	82.5	1 3/4 - 2 1/4	29.5	24.8	22.4	2.9	3.9	30.3	8	71.5	1265
VB 710.68.1.100.S	110	2 1/2 - 2 5/8	31.5	28	25.6	3.4	4.7	32.3	8	75.2	1605
VB 800.76.1.125.S	137.5	2 3/4 - 3	35	31.5	29.5	3.4	4.7	36.2	8	84.6	2200

Minimum Ultimate Strength = 4 x WLL

Also Available in Double Sheave Models:

VB 240.28.2.20.S*	22	1 - 1 1/8	11.8	9.4	10	1.5	1.9	12.2	6.2	26.9	200
VB 300.32.2.32.S	35	1 1/8 - 1 1/4	14.4	11.8	11.3	2.1	2.8	14.8	6.2	32.8	265
VB 345.32.2.36.5.S	40	1 1/8 - 1 1/4	15.7	13.6	12.8	2.1	2.8	16.1	8.2	48.6	500
VB 430.32.2.55.S	60	1 3/8 - 1 1/2	19.5	16.9	15.8	2.3	3.1	20.1	9.4	62	770
VB 430.28.2.73.S	80	1 1/8 - 1 1/2	19.5	16.9	16.1	2.8	3.9	20.1	9.6	61	880
VB 520.38.2.125.S	137.5	1 3/8 - 1 1/2	23.4	20.5	18.1	3.4	4.7	24	10.1	57.1	1345

* Available with and without Dead End

Minimum Ultimate Strength = 4 x WLL

WLL = Working Load Limit on head fitting.

- The dimensions in this table are indicative only. A drawing will always be submitted prior to production and will be the leading document when discussing dimensions.
- Blocks shown here are standard models; inquiries for custom versions are welcome.
- Refer to wire rope manufacturers D/d ratio guideline.
- Standard provided with bronze bearing. Roller bearing optional.



SEE OUR WARNING & SAFETY INFORMATION ON PAGES 136 - 149



HIGH CAPACITY LIGHT WEIGHT BLOCKS

LIGHT WEIGHT TILT-UP BLOCKS

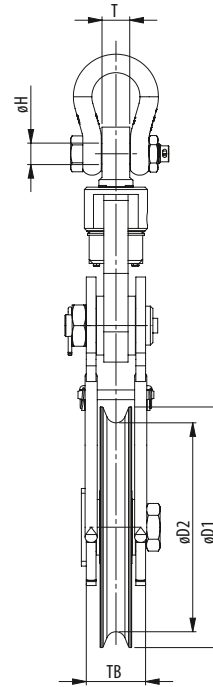
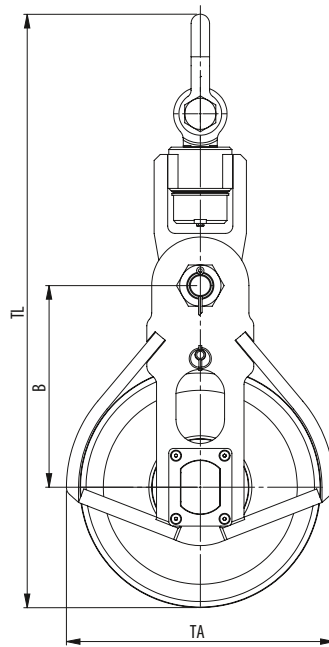

- Hook
- Clevis
- Tailboard
- Oblong eye

Model No.	WLL (UStons)	For wire ød (inch)	Dimensions (inch)								Weight (lbs)
			øD1	øD2	B	øH	T	TA	TB	TL	
HCLW 240.28.1.25.S	27.5	1 - 1½	11.8	9.4	10.2	1.6	2.1	14	4	28.7	155
HCLW 240.28.1.27.S	30	1 - 1½	11,8	9,4	10,2	1,7	2,2	12,9	4,4	30,2	183
HCLW 355.32.1.27.S	30	1½ - 1¼	16.5	14	14.8	1.7	2.2	18.7	4.4	39.1	265
HCLW 355.36.1.32.S	35	1¼ - 1¾	16.5	14	14.8	1.7	2.2	18.7	4.8	39.1	265
HCLW 430.32.1.27.S	30	1½ - 1¼	19.5	16.9	16.3	1.7	2.2	21.7	4.4	42.2	240
HCLW 430.32.1.32.S	35	1½ - 1¼	19.5	16.9	16.3	1.7	2.2	21.7	4.8	42.1	285
HCLW 430.38.1.32.S	35	1¼ - 1½	19.5	16.9	16.3	1.7	2.2	21.7	4.8	42.1	255
HCLW 430.38.1.40.S	45	1¼ - 1½	19.5	16.9	16.3	2	2.8	21.7	4.8	43.6	320
HCLW 520.38.1.55.S	60	1¼ - 1½	23.4	20.5	19.1	2.8	3.9	25.6	5.2	51.9	420
HCLW 520.44.1.55.S	60	1½ - 1¾	23.4	20.5	19.1	2.3	3.1	25.6	5.2	51.5	420
HCLW 520.52.1.55.S	60	1¾ - 2	23.4	20.5	19.1	2.3	3.1	25.6	5.2	51.5	420
HCLW 630.58.1.81.S	90	2 - 2¼	28	24.8	22.6	2.9	3.9	30.6	6	62.4	880
HCLW 630.64.1.81.S	90	2¼ - 2½	28	24.8	22.6	2.9	3.9	30.6	6	62.4	880
HCLW 760.70.1.110.S	120	2½ - 2¾	35.4	29.9	28.9	3.4	4.7	38.6	7.9	74.9	1200
HCLW 760.76.1.110.S	120	2¾ - 3	35.4	29.9	28.9	3.4	4.7	38.6	7.9	74.9	1200
HCLW 760.76.1.125.S	137.5	2¾ - 3	35.4	29.9	28.9	3.3	4.7	38.6	7.9	74.4	1320
HCLW 760.76.1.137,5.S	150	2¾ - 3	35.4	29.9	28.9	3.3	4.7	38.6	7.9	74.4	1540

Minimum Ultimate Strength = 4 x WLL

WLL= Working Load Limit on head fitting.

- The dimensions in this table are indicative only. A drawing will always be submitted prior to production and will be the leading document when discussing dimensions.
- Blocks shown here are standard models; inquiries for custom versions are welcome.
- Refer to wire rope manufacturers D/d ratio guideline.
- Standard provided with roller bearing. Bronze bearing optional.



SEE OUR WARNING & SAFETY INFORMATION ON PAGES 136 - 149



HIGH CAPACITY LIGHT WEIGHT BLOCKS

LIGHT WEIGHT TILT-UP BLOCKS

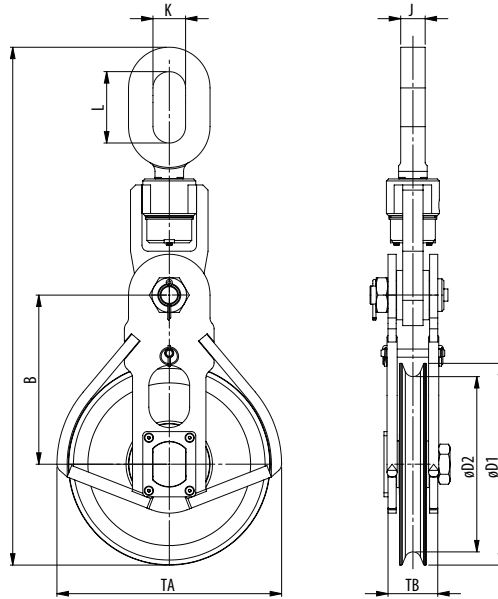

- Hook
- Clevis
- Tailboard
- Oblong eye

Model No.	WLL (USTons)	For wire ød (inch)	Dimensions (inch)									Weight (lbs)
			øD1	øD2	B	J	K	L	TA	TB	TL	
HCLW 240.28.1.25.O	27.5	1 - 1½	11.8	9.4	10.2	2	3	5.9	14	4	37.2	175
HCLW 355.32.1.27.O	30	1½ - 1¼	16.5	14	14.8	2.4	3.1	6.9	18.7	4.4	47	290
HCLW 355.36.1.32.O	35	1¼ - 1¾	16.5	14	14.8	2.4	3.1	6.9	18.7	4.8	47	290
HCLW 430.32.1.27.O	30	1½ - 1¼	19.5	16.9	16.3	2.4	3.1	6.9	21.7	4.4	50	275
HCLW 430.32.1.32.O	35	1½ - 1¼	19.5	16.9	16.3	2.4	3.1	6.9	21.7	4.4	49	310
HCLW 430.38.1.32.O	35	1¼ - 1½	19.5	16.9	16.3	2.4	3.1	6.9	21.7	4.8	50	290
HCLW 430.38.1.40.O	45	1¼ - 1½	19.5	16.9	16.3	2.6	3.5	7.9	21.7	4.8	51.6	340
HCLW 520.38.1.55.O	60	1¼ - 1½	23.4	16.9	19.1	2.8	3.5	8.9	25.6	5.2	60	480
HCLW 520.44.1.55.O	60	1½ - 1¾	23.4	20.5	19.1	2.8	3.9	8.9	25.6	5.2	60.5	480
HCLW 520.52.1.55.O	60	1¾ - 2	23.4	20.5	19.1	2.8	3.9	8.9	25.6	5.2	60.5	480
HCLW 630.58.1.81.O	90	2 - 2¼	28	24.8	22.6	3.1	4.3	9.8	30.6	6	74.1	915
HCLW 630.64.1.81.O	90	2¼ - 2½	28	24.8	22.6	3.1	4.3	9.8	30.6	6	74.1	915
HCLW 760.70.1.110.O	120	2½ - 2¾	35.4	29.9	28.9	3.7	4.9	10.8	38.6	7.9	86.2	1300
HCLW 760.76.1.110.O	120	2¾ - 3	35.4	29.9	28.9	3.7	4.9	10.8	38.6	7.9	86.2	1300
HCLW 760.76.1.125.O	137.5	2¾ - 3	35.4	29.9	28.9	3.9	4.9	10.8	38.6	7.9	86.2	1430
HCLW 760.76.1.137,5.O	150	2¾ - 3	35.4	29.9	28.9	3.9	4.9	10.8	38.6	7.9	86.2	1650

Minimum Ultimate Strength = 4 x WLL

WLL= Working Load Limit on head fitting.

- The dimensions in this table are indicative only. A drawing will always be submitted prior to production and will be the leading document when discussing dimensions.
- Blocks shown here are standard models; inquiries for custom versions are welcome.
- Refer to wire rope manufacturers D/d ratio guideline.
- Standard provided with roller bearing. Bronze bearing optional.



SEE OUR WARNING & SAFETY INFORMATION ON PAGES 136 - 149



SNATCH BLOCKS SELF LOCKING

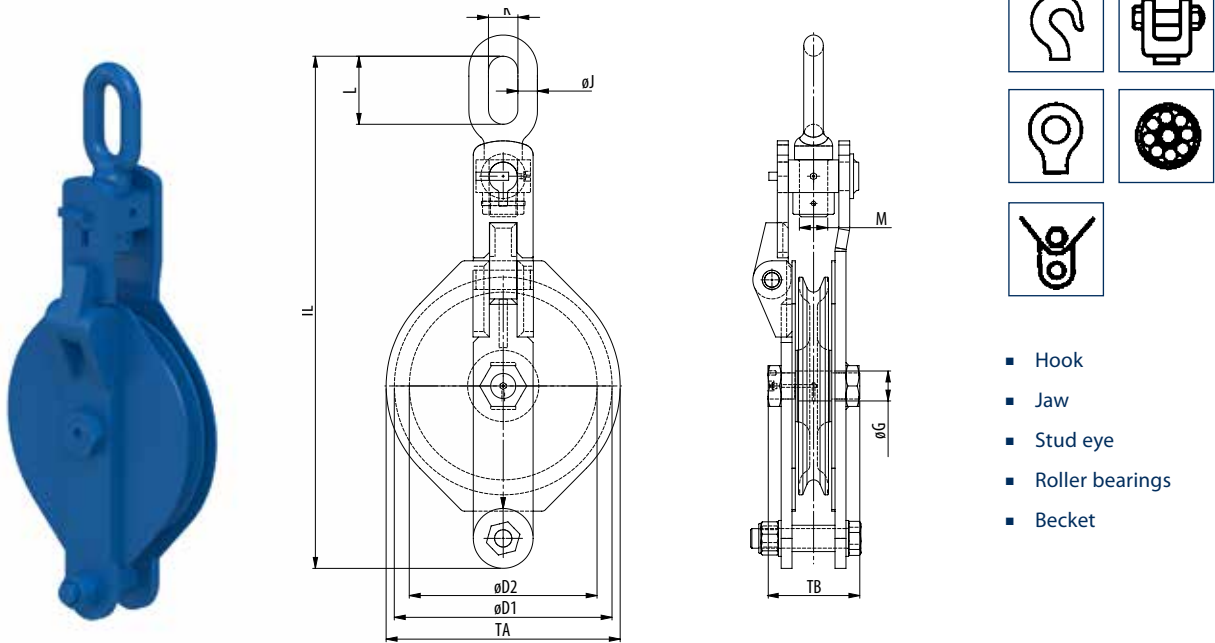

Model No. (+B for w. becket)	WLL (UStons)	for wire ød (inch)	Dimensions (inch)									Weight (lbs)	
			øD1	øD2	øG	øJ	K	L	M	TA	TB		TL
VBK 105.10.1.1.O	1.1	3/8	4.92	4.13	0.87	0.63	1.02	2.28	0.71	5.31	3.15	12.44	10
VBK 120.12.1.2.O	2.2	1/2	5.91	4.72	1.18	0.63	1.02	2.28	0.94	6.69	3.94	15.39	18
VBK 165.14.1.3.O	3.3	5/16	7.87	6.50	1.18	0.83	1.26	2.83	1.18	8.66	3.94	19.02	28
VBK 210.18.1.4.O	4.4	11/16	9.84	8.27	1.38	1.02	1.57	3.70	1.30	10.63	4.33	24.17	46
VBK 255.20.1.6.O	6.6	13/16	11.81	10.04	1.57	1.14	1.77	4.25	1.65	12.60	4.92	27.48	73
VBK 305.22.1.8.O	8.8	7/8	13.78	12.01	1.77	1.26	1.93	4.53	1.77	14.96	5.91	30.59	106
VBK 345.24.1.10.O	11.0	15/16	15.75	13.58	1.97	1.42	2.13	4.92	2.05	16.93	6.69	34.25	150
VBK 345.24.1.12.O	13.2	15/16	15.75	13.58	2.17	1.61	2.36	5.67	2.20	16.93	6.69	35.28	183
VBK 345.28.1.16.O	17.6	1 1/8	15.75	13.58	2.36	1.81	2.60	6.42	2.52	16.93	7.09	37.40	209
VBK 390.30.1.16.O	17.6	1 3/16	17.72	15.35	2.76	1.81	2.60	6.42	2.52	18.90	7.09	38.58	234
VBK 345.30.1.20.O	22.0	1 3/16	15.75	13.58	2.76	2.01	2.83	6.81	2.83	16.93	7.87	38.98	269
VBK 390.32.1.20.O	22.0	1 1/4	17.72	15.35	2.76	2.01	2.83	6.81	2.83	18.90	7.87	40.16	287
VBK 390.36.1.25.O	27.6	1 7/16	17.72	15.35	3.15	2.36	3.15	7.68	2.99	18.90	8.82	41.14	331
VBK 390.36.1.30.O	33.1	1 7/16	17.72	15.35	3.54	2.36	3.54	8.66	3.15	18.90	8.94	48.03	419
VBK 480.42.1.40.O	44.1	1 5/8	21.65	19.49	4.72	-	3.78	3.78	3.54	22.83	9.45	44.88	551

Minimum Ultimate Strength = 4 x WLL

WLL= Working Load Limit on head fitting.

- Snatch blocks can be supplied with becket, the last digit of the stock number should be 1 (instead of 0).
- Standard supplied with bronze bearings. • Other bearings available on request.
- Standard supplied with swivel oval eye up to 30 tons, for over 30 tons with swivel stud eye.
- Snatch blocks of 1 ton and over 30 tons are provided with a fixed trunnion and locking pin.
- Snatch blocks can be supplied with swivel hook, swivel stud eye or swivel jaw.
- Groove in sheave may be adjusted to other wire rope diameters.

SEE OUR WARNING & SAFETY INFORMATION ON PAGES 136 - 148



ANCHOR BOOM BLOCKS

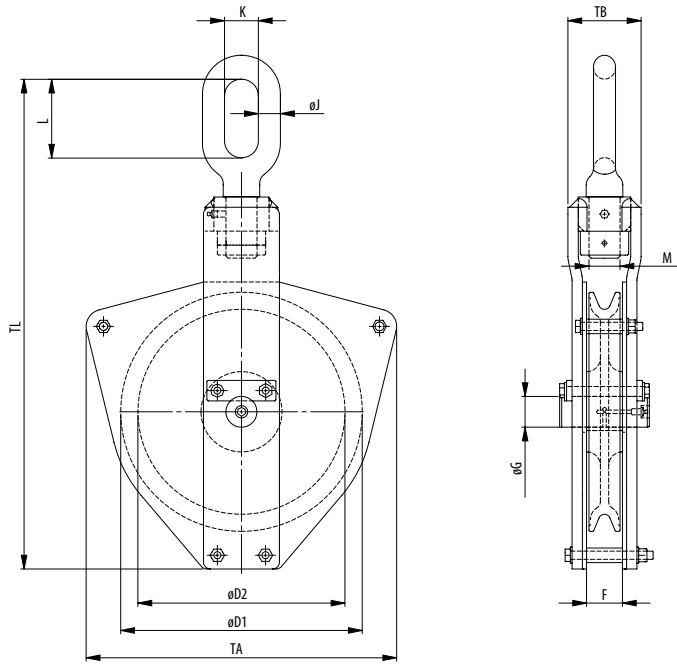

Model No.	WLL (UStons)	for wire ød (inch)	Dimensions (inch)												Weight (lbs)
			øD1	øD2	F	øG	øJ	K	L	M	R	TA	TB	TL	
BBA 165.10.1.3.O	3.3	3/8	7.87	6.50	1.57	1.18	0.83	1.26	2.83	1.18	0.22	10.63	9.06	18.31	30
BBA 210.12.1.4.O	4.4	1/2	9.84	8.27	1.77	1.38	1.02	1.57	3.70	1.30	0.26	12.60	11.02	21.89	49
BBA 255.14.1.6.O	6.6	5/16	11.81	10.04	1.97	1.57	1.14	1.77	4.25	1.65	0.30	15.75	14.17	25.71	77
BBA 300.18.1.8.O	8.8	11/16	13.78	11.81	1.77	1.77	1.26	1.93	4.53	1.77	0.37	17.72	15.75	28.11	159
BBA 345.20.1.12.O	13.2	13/16	15.75	13.58	1.97	2.36	1.61	2.36	5.67	2.20	0.43	19.76	17.32	39.92	187
BBA 390.22.1.16.O	17.6	7/8	17.72	15.35	2.36	2.76	1.81	2.60	6.42	2.52	0.47	22.05	20.08	43.07	231
BBA 430.24.1.18.O	19.8	15/16	19.69	16.93	2.76	2.95	2.01	2.83	6.81	2.83	0.51	24.02	20.47	43.19	298
BBA 430.36.1.20.O	22.0	17/16	19.69	16.93	2.76	3.15	2.01	2.83	6.81	2.83	0.77	24.41	21.65	43.86	362

Minimum Ultimate Strength = 4 x WLL

WLL= Working Load Limit on head fitting.

- Sheaves standard fitted with bronze bushing.
- Optionally supplied with roller thrust bearing for lifting eye.
- Groove in sheave may be adjusted to other wire rope diameters.



SEE OUR WARNING & SAFETY INFORMATION ON PAGES 136 - 149

GROOVE RADIUS GAUGES

STAINLESS STEEL

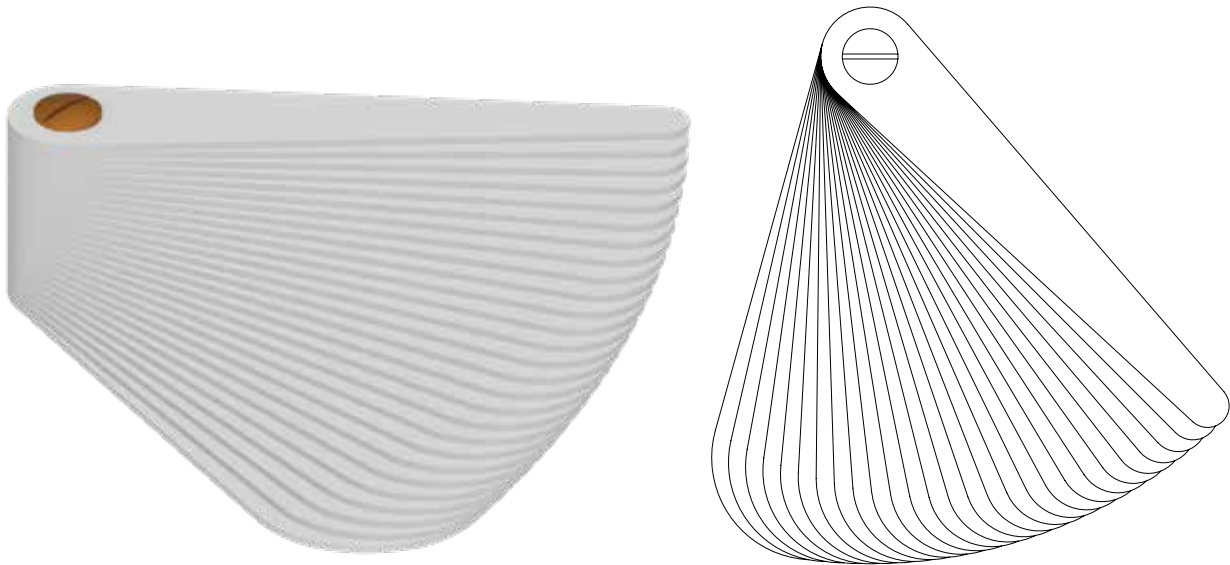

Model nr.	R-min (inch)	R-max (inch)	Steps (inch)
T G.3,5-16,5	0.14	0.65	0.02
T G.17-30	0.67	1.18	0.02
T G.4-25	0.16	0.98	0.02
T G.26-52	1.02	2.05	*
T G.30-40	1.18	1.57	0.02
T G.40-50	1.57	1.97	0.02

- Groove radius gauges enable the measuring of the radius in grooves of wire rope sheaves.
- Gauges only provide an indication of the radius of the groove and is not a calibrated measuring instrument.

* The steps differ in this model.



SEE OUR WARNING & SAFETY INFORMATION ON PAGES 136 - 149





SHEAVES

SHEAVES MADE SMART

Sheaves are key factors in terms of the performance of your application and the lifetime of the wire rope installed. That's why Ropeblock focuses on finding the best possible design and materials for each specific application. In many cases our cast sheaves are the solution of choice, if only because of their self-lubricating properties.

However, when weight is a paramount factor, our plastic sheaves could be the answer you are looking for. In some cases a welded sheave, a forged sheave or a sheave made out of solid material might be the appropriate choice.

Mind you, whatever the right Ropeblock sheave may be in your case, you can count on its being engineered for efficiency. Our extensive knowledge and experience allow us to employ Smart Engineering, creating highly functional solutions that will meet your needs in every respect.

Although the list of standard sheaves is extensive, specific factors such as wire rope type & diameter, wrap angle, fleet angle, line pull and application details should be considered. Please contact us in order to determine which sheave most suits your purposes.



Find more details about the graphite lubrication effect in this cast sheave on pages 8 & 9.



CAST SHEAVES

Ropeblock self-lubricating cast sheaves are often applied in lifting, luffing and wire rope routing with intensive operating cycles. The groove opening angle was carefully designed to reduce potential twist resulting from fleet angles. In combination with the self-lubricating effect, the wire rope in your system will last longer. The latter was proved in recent research, in which several sheave materials were compared in terms of their effect on rope twist. Details of this research, which was carried out in cooperation with a leading German University, can be found in the Research and

Development section in this catalogue. It should come as no surprise that Ropeblock has been using these sheaves in most blocks for over 25 years. In most cases our standard sheaves can be fine-tuned to suit your application with only minor modifications. The full range of standard cast sheaves can be found on the following pages.

NEXT TO OUR LARGE RANGE OF STANDARD SHEAVES WE WILL GLADLY INVESTIGATE WHETHER AN ENGINEERED SOLUTION, SPECIFICALLY DESIGNED FOR YOUR APPLICATION, COULD BE A GOOD SOLUTION AS WELL.

AVAILABLE FINISHES (DEPENDS ON THE APPLICATION)

Segment / application	ISO 12944 classification	Classification description	Expected protection duration	DFT (µm)
Construction	C2M	Slightly polluted atmosphere, predominately agriculture areas	5 to 15 year	120
Construction	C3M	Industrial and residential air pollution levels, with an average sulfur dioxide (IV) contamination level. Coastal areas with low salt content in air	2 to 5 year	120
Construction	C3M	Industrial and residential air pollution levels, with an average sulfur dioxide (IV) contamination level. Coastal areas with low salt content in air	5 to 15 year	160
Cargo handling	C3M	Industrial and residential air pollution levels, with an average sulfur dioxide (IV) contamination level. Coastal areas with low salt content in air	5 to 15 year	160
Cargo handling	C4H	Industrial areas and coastal areas with average salt content in air	more than 15 year	280
Cargo handling	C5-MM	Coastal areas and open sea with high salt content in air	5 to 15 year	280
Offshore	C4H	Industrial areas and coastal areas with average salt content in air	more than 15 year	300
Offshore	C5-MM	Coastal areas and open sea with high salt content in air	5 to 15 year	300
Offshore	C5-MH	Coastal areas and open sea with high salt content in air	more than 15 year	320
Offshore	NORSOK sys. 1*	Open sea with high salt content in air	more than 15 year	300



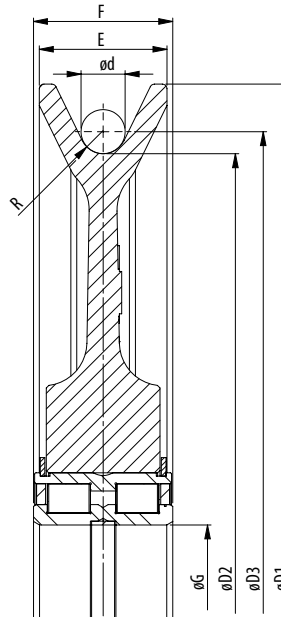

Model No.	Dimensions (inch)								Bearing	Weight (lbs)
	Sheave tread ø	Shaft ø	For wire ød	Groove radius	Outer ø	P.C.D.	Rim width	Bearing width		
	øD2	øG	d	R	øD1	øD3	E	F		
SE.225.5012.7,5	8.86	2.36	0.55	0.30	10.24	9.41	1.50	1.81	SL04 5012 PP	15
SE.227.5010.7	8.94	1.97	0.51	0.28	10.43	9.45	1.38	1.57	SL04 5010 PP	12
SE.250.5008B.6	9.84	1.57	0.43	0.24	11.42	10.28	1.26	1.50	SL04 5008 PP	13
SE.250.5008B.5,5	9.84	1.57	0.39	0.22	11.42	10.24	1.26	1.50	SL04 5008 PP	13
SE.250.5008B.7,2	9.84	1.57	0.51	0.28	11.42	10.35	1.26	1.50	SL04 5008 PP	14
SE.260.5012.8,5	10.24	2.36	0.63	0.33	11.81	10.87	1.65	1.81	SL04 5012 PP	20
SE.260.5012.6,5	10.24	2.36	0.47	0.26	11.81	10.71	1.65	1.81	SL04 5012 PP	21
SE.260.5012.7,5	10.24	2.36	0.55	0.30	11.81	10.79	1.65	1.81	SL04 5012 PP	21
SE.280.5010.7	11.02	1.97	0.51	0.28	12.60	11.54	1.42	1.57	SL04 5010 PP	18
SE.280.5010B.7	11.02	1.97	0.51	0.28	12.60	11.54	1.42	1.57	SL04 5010 PP	18
SE.280.5012.8,5	11.02	2.36	0.63	0.33	12.60	11.65	1.65	1.81	SL04 5012 PP	20
SE.280.5012.8	11.02	2.36	0.59	0.31	12.60	11.61	1.65	1.81	SL04 5012 PP	20
SE.280.5012.7	11.02	2.36	0.51	0.28	12.60	11.54	1.65	1.81	SL04 5012 PP	21
SE.280.5012.10	11.02	2.36	0.75	0.39	12.60	11.77	1.65	1.81	SL04 5012 PP	23
SE.280.4914.8,5	11.02	2.76	0.63	0.33	12.60	11.65	1.42	2.36	SL01 4914 ZZ	19
SE.280.4914.7	11.02	2.76	0.51	0.28	12.60	11.54	1.42	1.18	SL01 4914 ZZ	20
SE.295.5008B.8,5	11.61	1.57	0.63	0.33	12.99	12.24	1.26	1.50	SL04 5008 PP	19
SE.300.5008.7	11.81	1.57	0.51	0.28	13.78	12.32	1.38	1.50	SL04 5008 PP	15
SE.300.5010.7	11.81	1.97	0.51	0.28	13.78	12.32	1.50	1.57	SL04 5008 PP	15
SE.320.5011.8,8,M	12.60	2.17	0.63	0.35	15.12	13.23	1.69	1.81	SL04 5011 PP	23
SE.320.4914.8,5	12.60	2.17	0.63	0.33	15.12	13.23	1.69	1.81	SL01 4914	28
SE.320.5013.9	12.60	2.56	0.67	0.35	15.12	13.27	1.69	1.81	SL04 5013 PP	29
SE.320.5013.10	12.60	2.56	0.75	0.39	14.37	13.35	1.65	1.81	SL04 5013 PP	29



- The dimensions in this table are indicative only. A drawing will always be submitted prior to production and will be the leading document when discussing dimensions.
- Sheaves shown here are standard models; inquiries for custom versions are welcome.



SEE OUR WARNING & SAFETY
INFORMATION ON PAGES 136 - 149



Model No.	Dimensions (inch)								Bearing	Weight (lbs)
	Sheave tread ø	Shaft ø	For wire ød	Groove radius	Outer ø	P.C.D.	Rim width	Bearing width		
	øD2	øG	d	R	øD1	øD3	E	F		



SE.320.5013.8,5	12.60	2.56	0.63	0.33	14.37	13.23	1.65	1.81	SL04 5013PP	30
SE.345.5010B.9,5	13.58	1.97	0.71	0.37	15.16	14.29	1.42	1.57	SL04 5010 PP	28
SE.345.5010B.10	13.58	1.97	0.75	0.39	15.16	14.33	1.42	1.57	SL04 5010 PP	28
SE.350.5012.8	13.78	2.36	0.55	0.31	16.34	14.33	1.77	1.81	SL04 5012 PP	28
SE.354.5013.9,5	13.94	2.56	0.71	0.37	15.75	14.65	1.65	1.81	SL04 5013 PP	36
SE.355.5013.10	13.98	2.56	0.75	0.39	16.14	14.72	1.65	1.81	SL04 5013 PP	39
SE.355.5013.9,5	13.98	2.56	0.71	0.37	16.14	14.69	1.65	1.81	SL04 5013 PP	40
SE.355.5013.9	13.98	2.56	0.67	0.35	16.14	14.65	1.65	1.81	SL04 5013 PP	40
SE.355.5013.8,5	13.98	2.56	0.63	0.33	16.14	14.61	1.65	1.81	SL04 5013 PP	40
SE.355.5016.7,5	13.98	3.15	0.55	0.30	16.14	14.53	2.17	2.36	SL04 5016 PP	37
SE.355.5016.10	13.98	3.15	0.75	0.39	16.14	14.72	2.17	2.36	SL04 5016 PP	37
SE.355.5016.12	13.98	3.15	0.87	0.47	16.14	14.84	2.17	2.36	SL04 5016 PP	37
SE.355.4918.12	13.98	3.54	0.87	0.47	16.14	14.84	1.73	1.38	SL01 4918 ZZ	33
SE.355.4918.9	13.98	3.54	0.67	0.35	16.14	14.65	1.73	1.38	SL01 4918 ZZ	35
SE.355.4918.8,5	13.98	3.54	0.63	0.33	16.14	14.61	1.73	1.38	SL01 4918 ZZ	36
SE.355.4918.9,5	13.98	3.54	0.71	0.37	16.14	14.69	1.73	1.38	SL01 4918 ZZ	39
SE.355.4918.10	13.98	3.54	0.75	0.39	16.14	14.72	1.73	1.38	SL01 4918 ZZ	40
SE.355.4926.9	13.98	5.12	0.67	0.35	16.14	14.65	2.32	1.97	SL01 4926 PP	51
SE.360.5016.10	14.17	3.15	0.75	0.39	16.54	14.92	2.17	2.36	SL04 5016 PP	39
SE.360.5016.9,5	14.17	3.15	0.71	0.37	16.54	14.88	2.17	2.36	SL04 5016 PP	48
SE.360.5016.8,5	14.17	3.15	0.63	0.33	16.54	14.80	2.17	2.36	SL04 5016 PP	48
SE.360.4918.10	14.17	3.54	0.75	0.39	16.54	14.92	1.73	1.38	SL01 4918 ZZ	41
SE.360.4918.9,5	14.17	3.54	0.71	0.37	16.54	14.88	1.73	1.38	SL01 4918 ZZ	41
SE.360.4918.8,5	14.17	3.54	0.63	0.33	16.54	14.80	1.73	1.38	SL01 4918 ZZ	42
SE.373.5018.12	14.69	3.54	0.87	0.47	17.32	15.55	2.01	2.64	SL04 5018 PP	54
SE.400.5013.10	15.75	2.56	0.75	0.39	18.11	16.50	1.69	1.81	SL04 5013 PP	55
SE.400.5013.9,5	15.75	2.56	0.71	0.37	18.11	16.46	1.69	1.81	SL04 5013 PP	55
SE.400.5013.8,5	15.75	2.56	0.63	0.33	18.11	16.38	1.69	1.81	SL04 5013 PP	56
SE.400.5014B.11,5	15.75	2.76	0.83	0.45	18.11	16.57	1.93	2.13	SL04 5014 PP	54
SE.400.5014B.10	15.75	2.76	0.75	0.39	18.11	16.50	1.93	2.13	SL04 5014 PP	55
SE.400.5014B.9,5	15.75	2.76	0.71	0.37	18.11	16.46	1.93	2.13	SL04 5014 PP	56
SE.400.5016.12.A	15.75	3.15	0.87	0.47	18.11	16.61	1.97	2.36	SL04 5016 PP	56
SE.400.5016.15	15.75	3.15	1.10	0.59	18.11	16.85	2.83	2.36	SL04 160 PP	62
SE.400.5016.12	15.75	3.15	0.87	0.47	18.11	16.61	2.17	2.36	SL04 5016 PP	62
SE.400.5016.11,5	15.75	3.15	0.83	0.45	18.11	16.57	2.17	2.36	SL04 5016 PP	62
SE.400.5016.10	15.75	3.15	0.75	0.39	18.11	16.50	2.17	2.36	SL04 5016 PP	63
SE.400.4918.10	15.75	3.54	0.75	0.39	18.11	16.50	1.73	1.38	SL01 4918 ZZ	57
SE.400.5018.9,5	15.75	3.54	0.71	0.37	18.11	16.46	2.83	2.64	SL04 160 PP	62
SE.400.5018.12	15.75	3.54	0.87	0.47	18.11	16.61	2.44	2.64	SL04 5018 PP	66
SE.400.5018.11,5	15.75	3.54	0.83	0.45	18.11	16.57	2.44	2.64	SL04 5018 PP	67
SE.400.5018.10	15.75	3.54	0.75	0.39	18.11	16.50	2.44	2.64	SL04 5018 PP	68
SE.400.4922.10	15.75	4.33	0.75	0.39	18.11	16.50	1.97	1.57	SL01 4922 PP	56



- The dimensions in this table are indicative only. A drawing will always be submitted prior to production and will be the leading document when discussing dimensions.
- Sheaves shown here are standard models; inquiries for custom versions are welcome.



SEE OUR WARNING & SAFETY INFORMATION ON PAGES 136 - 149



Model No.	Dimensions (inch)								Bearing	Weight (lbs)
	Sheave tread ϕ	Shaft ϕ	For wire ϕ d	Groove radius	Outer ϕ	P.C.D.	Rim width	Bearing width		
	ϕ D2	ϕ G	d	R	ϕ D1	ϕ D3	E	F		
SE.400.4924.10	15.75	4.72	0.75	0.39	18.11	16.50	2.17	1.77	SL04 160 PP	56
SE.400.160.9,5	15.75	6.30	0.71	0.37	18.11	16.46	2.83	3.15	SL04 160 PP	74
SE.400.160.12	15.75	6.30	0.87	0.47	18.11	16.61	2.83	3.15	SL04 160 PP	74
SE.438.5018.12	17.24	3.54	0.87	0.47	19.69	18.11	2.28	2.64	SL04 5018 PP	61
SE.450.5018.15	17.72	3.54	1.10	0.59	20.28	18.82	2.44	2.64	SL04 5018 PP	86
SE.450.5018.13,5	17.72	3.54	0.98	0.53	20.28	18.70	2.44	2.64	SL04 5018 PP	88
SE.450.5018.12	17.72	3.54	0.87	0.47	20.28	18.58	2.44	2.64	SL04 5018 PP	89
SE.450.5018.10	17.72	3.54	0.75	0.39	20.28	18.46	2.44	2.64	SL04 5018 PP	91
SE.450.5018.10,5	17.72	3.54	0.79	0.41	20.28	18.50	2.44	2.64	SL04 5018 PP	91
SE.450.5018.13	17.72	3.54	0.94	0.51	20.28	18.66	2.44	2.64	SL04 5018 PP	91
SE.450.5024.15	17.72	4.72	1.10	0.59	20.28	18.82	2.95	3.15	SL04 5024 PP	100
SE.450.5024.13,5	17.72	4.72	0.98	0.53	20.28	18.70	2.95	3.15	SL04 5024 PP	102
SE.450.5024.12	17.72	4.72	0.87	0.47	20.28	18.58	2.95	3.15	SL04 5024 PP	103
SE.450.5024.10	17.72	4.72	0.75	0.39	20.28	18.46	2.95	3.15	SL04 5024 PP	105
SE.450.4926.12	17.72	5.12	0.87	0.47	20.28	18.58	2.36	1.97	SL01 4926 PP	83
SE.450.4926.10	17.72	5.12	0.75	0.39	20.28	18.46	2.36	1.97	SL01 4926 PP	84
SE.450.4926.13,5	17.72	5.12	0.98	0.53	20.28	18.70	2.36	1.97	SL01 4926 PP	92
SE.450.4830.10	17.72	5.91	0.75	0.39	20.28	18.46	2.17	1.57	SL01 4830	78
SE.450.160.10	17.72	6.30	0.75	0.39	20.28	18.46	2.95	3.15	SL04 160 PP	100
SE.482.5018.11	18.98	3.54	0.79	0.45	22.05	19.76	2.44	2.64	SL04 5018 PP	100
SE.482.5018.11,5	18.98	3.54	0.83	0.45	22.05	19.80	2.44	2.64	SL04 5018 PP	100
SE.482.5018.12	18.98	3.54	0.83	0.45	22.05	19.80	2.44	2.64	SL04 5018 PP	100
SE.482.5018.10,5	18.98	3.54	0.79	0.41	22.05	19.76	2.44	2.64	SL04 5018 PP	101
SE.482.5024.11	18.98	4.72	0.79	0.43	22.05	19.76	2.44	3.15	SL04 5024 PP	110
SE.482.160.11	18.98	6.30	0.79	0.43	22.05	19.76	2.44	3.15	SL04 160 PP	108
SE.500.5018B.13,5	19.69	3.54	0.98	0.53	22.44	20.67	2.40	2.64	SL04 5018 PP	103
SE.511.5020.10.M	20.12	3.94	0.75	0.39	22.99	20.87	2.24	2.64	SL04 5020 PP	63
SE.528.5018.14	20.79	3.54	1.02	0.55	23.43	21.81	2.40	2.64	SL04 5018 PP	100
SE.528.5018.15	20.79	3.54	1.10	0.59	23.43	21.89	2.40	2.64	SL04 5018 PP	110
SE.528.5018.13,5	20.79	3.54	0.98	0.53	23.43	21.77	2.40	2.64	SL04 5018 PP	111
SE.528.5018.12	20.79	3.54	0.87	0.47	23.43	21.65	2.40	2.64	SL04 5018 PP	112
SE.528.5018.13	20.79	3.54	0.94	0.51	23.43	21.73	2.40	2.64	SL04 5018 PP	112
SE.528.5018.14.B	20.79	3.54	1.02	0.55	23.43	21.81	2.40	2.64	SL04 5018 PP	112
SE.528.5024.15	20.79	4.72	1.10	0.59	23.43	21.89	2.91	3.15	SL04 5024 PP	125
SE.528.5024.13,5	20.79	4.72	0.98	0.53	23.43	21.77	2.91	3.15	SL04 5024 PP	127
SE.528.5024.14	20.79	4.72	1.02	0.55	23.43	21.81	2.91	3.15	SL04 5024 PP	140
SE.528.160.15	20.79	6.30	1.10	0.59	23.43	21.89	2.83	3.15	SL04 160 PP	116
SE.528.160.14	20.79	6.30	1.02	0.55	23.43	21.81	2.91	3.15	SL04 160 PP	117
SE.528.160.13,5	20.79	6.30	0.98	0.53	23.43	21.77	2.91	3.15	SL04 160 PP	118
SE.528.160.13	20.79	6.30	0.94	0.51	23.43	21.73	2.91	3.15	SL04 160 PP	135
SE.528.4836.13	20.79	7.09	0.94	0.51	23.43	21.73	2.32	1.77	SL01 4836 PP	105
SE.528.200.13	20.79	7.87	0.94	0.51	23.43	21.73	2.91	3.15	SL04 200 PP	125



- The dimensions in this table are indicative only. A drawing will always be submitted prior to production and will be the leading document when discussing dimensions.
- Sheaves shown here are standard models; inquiries for custom versions are welcome.



Model No.	Dimensions (inch)								Bearing	Weight (lbs)
	Sheave tread ø	Shaft ø	For wire ød	Groove radius	Outer ø	P.C.D.	Rim width	Bearing width		
	øD2	øG	d	R	øD1	øD3	E	F		



SE.528.200.13,5	20.79	7.87	0.98	0.53	23.43	21.77	2.91	3.15	SL04 200 PP	125
SE.528.200.15	20.79	7.87	1.10	0.59	23.43	21.89	2.91	3.15	SL04 200 PP	143
SE.536.130.14.M	21.10	5.12	1.02	0.55	24.02	22.13	2.56	3.15	SL04 130 PP	99
SE.575.5022.16	22.64	4.33	1.18	0.63	25.59	23.82	2.91	3.15	SL04 5022 PP	159
SE.575.5022.14	22.64	4.33	1.02	0.55	25.59	23.66	2.91	3.15	SL04 5022 PP	162
SE.575.5022.15	22.64	4.33	1.10	0.59	25.59	23.74	2.91	3.15	SL04 5022 PP	162
SE.575.5024.17	22.64	4.72	1.26	0.67	25.59	23.90	2.91	3.15	SL04 5024 PP	156
SE.575.5024.15	22.64	4.72	1.10	0.59	25.59	23.74	2.91	3.15	SL04 5024 PP	158
SE.575.5024.16	22.64	4.72	1.18	0.63	25.59	23.82	2.91	3.15	SL04 5024 PP	158
SE.575.5024.14	22.64	4.72	1.02	0.55	25.59	23.66	2.91	3.15	SL04 5024 PP	160
SE.575.160.15	22.64	6.30	1.10	0.59	25.59	23.74	2.91	3.15	SL04 160 PP	157
SE.575.160.14	22.64	6.30	1.02	0.55	25.59	23.66	2.91	3.15	SL04 160 PP	158
SE.575.200.15	22.64	7.87	1.10	0.59	25.59	23.74	2.91	3.15	SL04 200 PP	167
SE.575.200.14	22.64	7.87	1.02	0.55	25.59	23.66	2.91	3.15	SL04 200 PP	169
SE.630.5022B.16	24.80	4.33	1.18	0.63	27.95	25.98	2.91	3.15	SL04 5022 PP	184
SE.630.5024.17	24.80	4.72	1.26	0.67	27.95	26.06	2.91	3.15	SL04 5024 PP	183
SE.630.5024.16	24.80	4.72	1.18	0.63	27.95	25.98	2.91	3.15	SL04 5024 PP	184
SE.630.5024.15	24.80	4.72	1.10	0.59	27.95	25.91	2.91	3.15	SL04 5024 PP	186
SE.630.160.17	24.80	6.30	1.26	0.67	27.95	26.06	2.91	3.15	SL04 160 PP	179
SE.630.160.16	24.80	6.30	1.18	0.63	27.95	25.98	2.91	3.15	SL04 160 PP	181
SE.630.160.15	24.80	6.30	1.10	0.59	27.95	25.91	2.91	3.15	SL04 160 PP	182
SE.630.200.17	24.80	7.87	1.26	0.67	27.95	26.06	2.91	3.15	SL04 200 PP	190
SE.630.200.16	24.80	7.87	1.18	0.63	27.95	25.98	2.91	3.15	SL04 200 PP	191
SE.630.200.15	24.80	7.87	1.10	0.59	27.95	25.91	2.91	3.15	SL04 200 PP	193
SE.646.5030.18	25.43	5.91	1.34	0.71	29.13	26.77	3.15	3.94	SL04 5030 PP	200
SE.670.5024.17	26.38	4.72	1.26	0.67	29.92	27.64	2.91	3.15	SL04 5024 PP	197
SE.670.5024.15	26.38	4.72	1.10	0.59	29.92	27.48	2.91	3.15	SL04 5024 PP	201
SE.670.5024.13,5	26.38	4.72	0.98	0.53	29.92	27.36	2.91	3.15	SL04 5024 PP	204
SE.670.160.17	26.38	6.30	1.26	0.67	29.92	27.64	2.91	3.15	SL04 160 PP	199
SE.670.160.15	26.38	6.30	1.10	0.59	29.92	27.48	2.91	3.15	SL04 160 PP	203
SE.670.160.13,5	26.38	6.30	0.98	0.53	29.92	27.36	2.91	3.15	SL04 160 PP	206
SE.670.200.13,5	26.38	7.87	0.98	0.53	29.92	27.36	2.91	3.15	SL04 200 PP	206
SE.670.200.17	26.38	7.87	1.26	0.67	29.92	27.64	2.91	3.15	SL04 200 PP	210
SE.670.200.15	26.38	7.87	1.10	0.59	29.92	27.48	2.91	3.15	SL04 200 PP	213
SE.685.5028.16	26.97	5.51	1.18	0.63	31.22	28.15	3.54	3.74	SL04 5028 PP	279
SE.685.5028.18	26.97	5.51	1.34	0.71	31.22	28.31	3.54	3.74	SL04 5028 PP	279
SE.688.5024.17	27.09	4.72	1.26	0.67	30.71	28.35	2.91	3.15	SL04 5024 PP	231
SE.688.5036.17	27.09	7.09	1.26	0.67	30.71	28.35	2.91	5.35	SL04 5036 PP	275
SE.710.5022.18	27.95	4.33	1.34	0.71	31.50	29.29	2.83	3.15	SL04 5022 PP	217
SE.710.5022.17	27.95	4.33	1.26	0.67	31.50	29.21	2.83	3.15	SL04 5022 PP	220
SE.710.5024.18	27.95	4.72	1.34	0.71	31.50	29.29	2.83	3.15	SL04 5024 PP	208
SE.710.5024.20	27.95	4.72	1.50	0.79	31.50	29.45	2.83	3.15	SL04 5024 PP	208



- The dimensions in this table are indicative only. A drawing will always be submitted prior to production and will be the leading document when discussing dimensions.
- Sheaves shown here are standard models; inquiries for custom versions are welcome.



SEE OUR WARNING & SAFETY INFORMATION ON PAGES 136 - 149



Model No.	Dimensions (inch)								Bearing	Weight (lbs)
	Sheave tread ϕ	Shaft ϕ	For wire ϕ d	Groove radius	Outer ϕ	P.C.D.	Rim width	Bearing width		
	ϕ D2	ϕ G	d	R	ϕ D1	ϕ D3	E	F		
SE.710.5026.18	27.95	5.12	1.34	0.71	31.50	29.29	3.07	3.74	SL04 5026 PP	216
SE.710.5028.18	27.95	5.51	1.34	0.71	31.89	29.29	3.35	3.74	SL04 5028 PP	235
SE.710.5028.17	27.95	5.51	1.26	0.67	31.89	29.21	3.35	3.74	SL04 5028 PP	237
SE.710.5030.18	27.95	5.91	1.34	0.71	31.89	29.29	3.54	3.94	SL04 5030 PP	238
SE.710.5030.17	27.95	5.91	1.26	0.67	31.89	29.21	3.54	3.94	SL04 5030 PP	240
SE.720.5030.18	28.35	5.91	1.34	0.71	32.68	29.69	3.54	3.94	SL04 5030 PP	248
SE.750.226.13	29.53	10.24	0.94	0.51	32.68	30.47	2.83	3.70	SL04 260 PP	358
SE.760.5026.20,5	29.92	5.12	1.54	0.81	33.86	31.46	2.95	3.74	SL04 5026 PP	304
SE.760.5030.20	29.92	5.91	1.50	0.79	33.86	31.42	3.35	3.94	SL04 5030 PP	295
SE.760.220.22	29.92	8.66	1.61	0.87	34.65	31.54	3.54	3.74	SL04 220 PP	314
SE.760.220.21	29.92	8.66	1.57	0.83	34.65	31.50	3.54	3.74	SL04 220 PP	317
SE.800.5022.16,5	31.50	4.33	1.22	0.63	35.04	32.72	2.76	3.15	SL04 5022 PP	300
SE.800.5024.16	31.50	4.72	1.18	0.63	35.04	32.68	2.76	3.15	SL04 5024 PP	280
SE.800.5024.20	31.50	4.72	1.50	0.79	35.04	32.99	2.76	3.15	SL04 5024 PP	280
SE.800.5026.17	31.50	5.12	1.26	0.67	35.04	32.76	2.95	3.74	SL04 5026 PP	286
SE.800.5026.18	31.50	5.12	1.34	0.71	35.04	32.83	2.95	3.74	SL04 5026 PP	294
SE.800.5026.20	31.50	5.12	1.50	0.79	35.04	32.99	2.95	3.74	SL04 5026 PP	294
SE.800.5028.22,5	31.50	5.51	1.65	0.89	35.04	33.15	3.35	3.74	SL04 5028 PP	328
SE.800.5028.21	31.50	5.51	1.57	0.83	35.04	33.07	3.35	3.74	SL04 5028 PP	331
SE.800.5028.20	31.50	5.51	1.50	0.79	35.04	32.99	3.35	3.74	SL04 5028 PP	333
SE.800.5028.19	31.50	5.51	1.42	0.75	35.04	32.91	3.35	3.74	SL04 5028 PP	335
SE.800.5030.23,5	31.50	5.91	1.73	0.93	35.04	33.23	3.54	3.94	SL04 5030 PP	329
SE.800.5030.21	31.50	5.91	1.57	0.83	35.04	33.07	3.54	3.94	SL04 5030 PP	335
SE.800.5030.20	31.50	5.91	1.50	0.79	35.04	32.99	3.54	3.94	SL04 5030 PP	337
SE.800.5030.22,5	31.50	5.91	1.65	0.89	35.04	33.15	3.54	3.94	SL04 5030 PP	352
SE.816.5028.18	32.13	5.51	1.34	0.71	36.06	33.46	3.15	3.74	SL04 5028 PP	321
SE.822.5026.15	32.36	5.12	1.10	0.59	35.67	33.46	2.95	3.74	SL04 5026 PP	277
SE.830.232.15	32.68	6.30	1.10	0.59	35.83	33.78	2.87	4.17	NJ-232-E	488
SE.850.232.15	33.46	6.30	1.10	0.59	37.01	34.57	3.15	4.17	NJ-232-E	438
SE.864.324.15	34.02	4.72	1.10	0.59	38.39	35.12	3.94	2.17	2x NJ-324-E	341
SE.864.324.19	34.02	4.72	1.42	0.75	38.39	35.43	3.94	2.17	2x NJ-324-E	341
SE.874.5036.23,5	34.41	7.09	1.73	0.93	39.53	36.14	4.21	5.35	SL04 5036 PP	563
SE.876.260.26,5	34.49	10.24	1.97	1.04	40.00	36.46	4.06	3.70	SL04 260 PP	527
SE.900.5026.19	35.43	5.12	1.42	0.75	39.76	36.85	3.43	3.74	SL04 5026 PP	385
SE.900.5030.22,5	35.43	5.91	1.65	0.89	39.76	37.09	3.43	3.94	SL04 5030 PP	389
SE.900.5030.23,5	35.43	5.91	1.73	0.93	39.76	37.17	3.43	3.94	SL04 5030 PP	389
SE.900.5030.25,5	35.43	5.91	1.89	1.00	39.76	37.32	3.43	3.94	SL04 5030 PP	389
SE.950.260.26,5	37.40	10.24	1.97	1.04	43.07	39.37	4.33	3.70	SL04 260 PP	560
SE.960.5034.21,5.H	37.80	6.69	1.57	0.85	42.52	39.37	4.33	4.80	SL04 5034 PP	565
SE.960.5034.23,5	37.80	6.69	1.73	0.93	42.52	39.53	4.33	4.80	SL04 5034 PP	565
SE.960.5036.21,5	37.80	7.09	1.57	0.85	42.52	39.37	4.33	5.35	SL04 5036 PP	572
SE.960.5036.21,5.H	37.80	7.09	1.57	0.85	42.52	39.37	4.33	5.35	SL04 5036 PP	579



- The dimensions in this table are indicative only. A drawing will always be submitted prior to production and will be the leading document when discussing dimensions.
- Sheaves shown here are standard models; inquiries for custom versions are welcome.



Model No.	Dimensions (inch)								Bearing	Weight (lbs)
	Sheave tread ø	Shaft ø	For wire ød	Groove radius	Outer ø	P.C.D.	Rim width	Bearing width		
	øD2	øG	d	R	øD1	øD3	E	F		
SE.960.5038.21,5	37.80	7.48	1.57	0.85	42.52	39.37	4.33	5.35	SL04 5038 PP	572
SE.960.5040.21,5,H	37.80	7.87	1.57	0.85	42.52	39.37	4.33	5.91	SL04 5040 PP	587
SE.1004.5030.27	39.53	5.91	2.01	1.07	44.06	41.54	3.74	3.94	SL04 5030 PP	436
SE.1010.5022.18,5	39.76	4.33	1.38	0.73	43.90	41.14	3.15	2.56	SL04 5022 PP	438
SE.1040.5034.30	40.94	6.69	2.20	1.18	46.46	43.15	4.49	4.80	SL04 5034PP	613
SE.1040.5034.23,5	40.94	6.69	1.73	0.93	46.46	42.68	4.33	3.90	SL04 5034 PP	634
SE.1040.5036.26,5	40.94	7.09	1.97	1.04	46.46	42.91	4.49	4.33	SL04 5036 PP	711
SE.1040.5038.30	40.94	7.48	2.20	1.18	46.46	43.15	4.49	5.35	SL04 5038PP	627
SE.1060.5044.37	41.73	8.66	2.76	1.46	47.24	44.49	5.51	5.87	SL04 5044 PP	1052
SE.1120.5034.29,5	44.09	6.69	2.17	1.16	50.39	46.26	4.92	3.90	SL04 5034 PP	876
SE.1120.5038.27	44.09	7.48	2.01	1.06	50.39	46.10	4.92	4.33	SL04 5038 PP	893
SE.1130.5044.27	44.49	8.66	2.01	1.06	51.18	46.50	5.75	5.12	SL04 5044 PP	1071
SE.1200.5040.27,5	47.24	7.87	2.05	1.08	53.94	49.29	5.51	4.72	SL04 5040PP	1140
SE.1200.5044.32	47.24	8.66	2.36	1.26	53.94	49.61	5.75	6.30	SL04 5044 PP	1124
SE.1250.5044.29	49.21	8.66	2.13	1.14	55.71	51.34	5.31	5.12	SL04 5044 PP	1459
SE.1280.5044.34	50.39	8.66	2.52	1.34	57.87	52.91	5.83	6.30	SL04 5044 PP	1373
SE.1280.5044.30	50.39	8.66	2.20	1.18	57.87	52.60	5.83	5.12	SL04 5044 PP	1384
SE.1280.5044.32	50.39	8.66	2.36	1.26	57.87	52.76	5.83	5.12	SL04 5044 PP	1384
SE.1445.5052.39,5	56.89	10.24	2.95	1.56	65.39	59.84	6.69	6.06	SL04 5052 PP	2246
SE.1540.5056.38	57.09	11.02	2.83	1.50	68.70	59.92	6.69	6.06	SL04 5056 PP	2486
SE.1820.5052.39,5	71.65	10.24	2.95	1.56	80.55	74.61	6.69	6.06	SL04 5052 PP	2933
SE.2660.5056.38	104.72	11.02	2.83	1.50	112.80	107.56	6.30	7.48	SL04 5056 PP	5101

- The dimensions in this table are indicative only. A drawing will always be submitted prior to production and will be the leading document when discussing dimensions.
- Sheaves shown here are standard models; inquiries for custom versions are welcome.



SEE OUR WARNING & SAFETY INFORMATION ON PAGES 136 - 149

CAST SHEAVES, RIGGING

WITH BALL BEARINGS

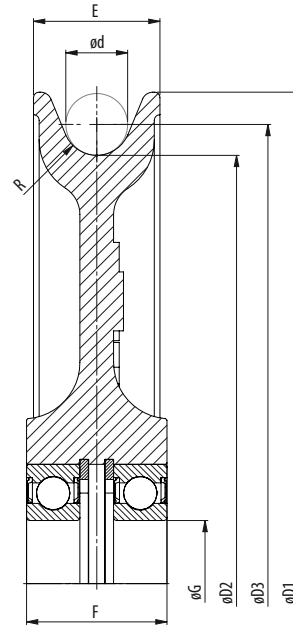

Model No.	Dimensions (inch)								Bearing	Weight (lbs)
	Sheave tread ø	Shaft ø	For wire ød	Groove radius	Outer ø	P.C.D.	Rim width	Bearing width		
	øD2	øG	d	R	øD1	øD3	E	F		
SEF.80.6002.4,5	3.15	0.59	0.31	0.18	3.94	3.46	0.71	0.79	2x6002-RS	2
SEF.105.60-22.5,5	4.13	0.87	0.39	0.22	4.92	4.53	0.91	1.08	2x6022-RS	3
SEF.120.6206.6,5	4.72	1.18	0.47	0.26	5.91	5.20	1.42	1.57	2x6206-RS	7
SEF.165.6206.7,5	6.50	1.18	0.55	0.30	7.87	7.05	1.42	1.57	2x6206-RS	10
SEF.210.6207.9,5	8.27	1.38	0.71	0.37	9.84	8.98	1.57	1.77	2x6207-RS	18
SEF.255.6208.11	10.04	1.57	0.79	0.43	11.81	10.83	1.77	1.97	2x6208-RS	26
SEF.305.6209.12	12.01	1.77	0.87	0.47	13.78	12.87	1.77	1.97	2x6209-RS	37
SEF.345.6210.13	13.58	1.97	0.94	0.51	15.75	14.53	2.17	2.36	2x6210-RS	53

- Different shaft sizes possible.
- Groove may be adjusted to other wire rope diameters.

 SEE OUR WARNING & SAFETY INFORMATION ON PAGES 136 - 149



CAST SHEAVES, RIGGING

WITH CYLINDRICAL ROLLER BEARINGS

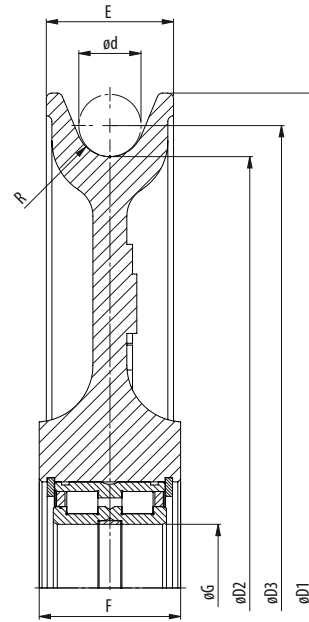

Model No.	Dimensions (inch)								Bearing	Weight (lbs)
	Sheave tread ø	Shaft ø	For wire ød	Groove radius	Outer ø	P.C.D.	Rim width	Bearing width		
	øD2	øG	d	R	øD1	øD3	E	F		
SEF.120.5005.6,5	4.72	0.98	0.47	0.26	5.91	5.20	1.42	1.57/1.18	SL04 5005 PP	15
SEF.120.5006.6,5	4.72	1.18	0.47	0.26	5.91	5.20	1.42	1.57/1.33	SL04 5006 PP	7
SEF.165.5006.7,5	6.50	1.18	0.55	0.30	7.87	7.05	1.42	1.57/1.33	SL04 5006 PP	10
SEF.195.5012.12	7.68	2.36	0.87	0.47	9.84	8.54	1.97	2.36	SL04 5012 PP	29
SEF.210.5007.9,5	8.27	1.38	0.71	0.37	9.84	8.98	1.57	1.77/1.41	SL04 5007 PP	18
SEF.255.5008.9,5	8.27	1.57	0.71	0.39	9.84	8.98	1.34	1.50	SL04 5008 PP	13
SEF.210.5008.6	8.27	1.57	0.43	0.24	9.84	8.70	1.34	1.50	SL04 5008 PP	14
SEF.210.5008.9,5	8.27	1.57	0.71	0.37	9.84	8.98	1.57	1.77/1.41	SL04 5008 PP	18
SEF.250.5013.13	9.84	2.56	0.94	0.51	11.81	10.79	2.17	2.36	SL04 5013 PP	29
SEF.255.5008.11	10.04	1.57	0.79	0.43	11.81	10.83	1.77	1.96/1.49	SL04 5008 PP	26
SEF.255.5010.8,5	10.04	1.97	0.63	0.33	11.81	10.67	1.42	1.57	SL04 5010 PP	19
SEF.305.5009.12	12.01	1.77	0.87	0.47	13.78	12.87	1.77	1.96/1.57	SL04 5009 PP	37
SEF.305.5012.8,5	12.01	2.36	0.63	0.33	13.78	12.64	1.77	1.81	SL04 5012 PP	30
SEF.305.5015.14	12.01	2.95	1.02	0.55	13.78	13.03	2.76	2.76	SL04 5015 PP	51
SEF.345.5010.13	13.58	1.97	0.94	0.51	15.75	14.53	2.17	2.36/1.57	SL04 5010 PP	53
SEF.345.5018.15	13.58	3.54	1.10	0.59	15.75	14.69	2.95	2.13	SL04 5018 PP	66
SEF.345.5014.9,5	13.58	4.72	0.71	0.37	15.75	14.29	1.97	2.13	SL04 5024 PP	48
SEF.390.5011.15	15.35	2.17	1.10	0.59	17.72	16.46	2.36	2.76/1.81	SL04 5011 PP	106
SEF.390.5016.11	15.35	3.15	0.79	0.43	17.72	16.14	2.36	2.36	SL04 5016 PP	68
SEF.390.5020.17	15.35	3.94	1.26	0.67	17.72	16.61	2.95	3.35	SL04 5020 PP	84
SEF.430.5012.16	16.93	2.36	1.18	0.63	19.69	18.11	2.76	3.14/1.81	SL04 5012 PP	97
SEF.430.5018.12	16.93	3.54	0.87	0.47	19.69	17.80	2.76	2.64	SL04 5018 PP	98
SEF.430.5024.19,5	16.93	4.72	1.42	0.77	19.69	18.35	2.95	4.13	SL04 5024 PP	169
SEF.480.5014.18	18.90	2.76	1.34	0.71	21.65	20.24	2.76	3.14/2.12	SL04 5014 PP	121
SEF.480.5024.21,5	18.90	4.72	1.57	0.85	21.65	20.47	3.15	4.13	SL04 5024 PP	209
SEF.520.5016.19	20.47	3.15	1.42	0.75	23.62	21.89	3.35	4.13/2.36	SL04 5016 PP	176
SEF.560.5020.20,5	22.05	3.94	1.54	0.81	26.18	23.58	3.94	4.33	SL04 5020 PP	242
SEF.630.5024.21,5	24.80	4.72	1.57	0.85	27.95	26.38	3.35	4.33/3.14	SL04 5024 PP	275
SEF.710.5030.23,5	27.95	5.91	1.73	0.93	31.89	29.69	3.86	3.94	SL04 5030 PP	289
SEF.710.5030.22,5	27.95	5.91	1.65	0.89	31.89	29.61	3.86	3.94	SL04 5030 PP	418
SEF.800.5032.23,5	31.50	6.30	1.73	0.93	36.22	33.23	3.94	4.29	SL04 5032 PP	473
SEF.920.5032.25,5	36.22	6.30	1.89	1.00	40.55	38.11	5.12	5.91	SL04 5032 PP	836
SEF.1020.5036.27,5	40.16	7.09	2.05	1.08	45.67	42.20	5.51	6.30	SL04 5036 PP	1188

- Different shaft sizes possible.
- Groove may be adjusted to other wire rope diameters.



SEE OUR WARNING & SAFETY INFORMATION ON PAGES 136 - 149



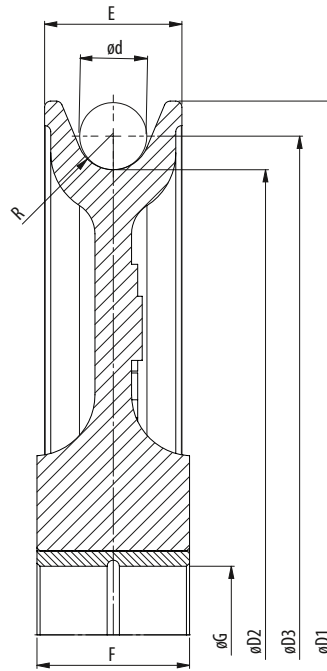

Model No.	Dimensions (inch)								Bearing	Weight (lbs)
	Sheave tread ø	Shaft ø	For wire ød	Groove radius	Outer ø	P.C.D.	Rim width	Bearing width		
	øD2	øG	d	R	øD1	øD3	E	F		
SEF.80.15.20.4,5	3.15	0.59	0.31	0.18	3.94	3.46	0.71	0.79	Bronze	1
SEF.105.22.27.5,5	4.13	0.87	0.39	0.22	4.92	4.53	0.91	1.06	Bronze	3
SEF.120.30.40.6,5	4.72	1.18	0.47	0.26	5.91	5.20	1.42	1.57	Bronze	7
SEF.165.30.40.7,5	6.50	1.18	0.55	0.30	7.87	7.05	1.42	1.57	Bronze	10
SEF.195.60.60.12	7.68	2.36	0.87	0.47	9.84	8.54	1.97	2.36	Bronze	26
SEF.210.35.45.9,5	8.27	1.38	0.71	0.37	9.84	8.98	1.57	1.77	Bronze	18
SEF.240.80.62.15	9.45	3.15	1.10	0.59	11.81	10.55	2.28	2.44	Bronze	26
SEF.250.50.60.8,5	9.84	1.97	0.63	0.33	11.81	10.47	1.77	2.36	Bronze	31
SEF.250.70.60.13	9.84	2.76	0.94	0.51	11.81	10.79	2.17	2.36	Bronze	33
SEF.255.40.50.11	10.04	1.57	0.79	0.43	11.81	10.83	1.77	1.97	Bronze	26
SEF.300.80.62.17	11.81	3.15	1.26	0.67	14.37	13.07	2.28	2.44	Bronze	33
SEF.300.80.62.15	11.81	3.15	1.10	0.59	14.37	12.91	2.28	2.44	Bronze	35
SEF.305.45.50.12	12.01	1.77	0.87	0.47	13.78	12.87	1.77	1.97	Bronze	37
SEF.305.50.50.12	12.01	1.97	0.87	0.47	13.78	12.87	1.77	1.97	Bronze	31
SEF.305.70.75.14	12.01	2.76	1.02	0.55	13.78	13.03	2.76	2.95	Bronze	44
SEF.345.50.65.13	13.58	1.97	0.94	0.51	15.75	14.53	2.17	2.56	Bronze	52
SEF.345.50.60.13	13.58	1.97	0.94	0.51	15.75	14.53	2.17	2.36	Bronze	53
SEF.345.55.65.13	13.58	2.17	0.94	0.51	15.75	14.53	2.17	2.56	Bronze	52
SEF.345.60.60.13	13.58	2.36	0.94	0.51	15.75	14.53	2.17	2.36	Bronze	50
SEF.345.60.70.16	13.58	2.36	1.18	0.63	15.75	14.76	2.17	2.76	Bronze	50
SEF.345.60.70.15	13.58	2.36	1.10	0.59	15.75	14.69	2.17	2.76	Bronze	51
SEF.345.70.70.16	13.58	2.76	1.18	0.63	15.75	14.76	2.17	2.76	Bronze	49



- Different shaft sizes possible.
- Groove may be adjusted to other wire rope diameters.

SEE OUR WARNING & SAFETY INFORMATION ON PAGES 136 - 149



Model No.	Dimensions (inch)								Bearing	Weight (lbs)
	Sheave tread ø	Shaft ø	For wire ød	Groove radius	Outer ø	P.C.D.	Rim width	Bearing width		
	øD2	øG	d	R	øD1	øD3	E	F		
SEF.345.70.70.15	13.58	2.76	1.10	0.59	15.75	14.69	2.17	2.76	Bronze	50
SEF.345.80.80.19	13.58	3.15	1.42	0.75	15.75	15.00	2.76	3.15	Bronze	67
SEF.345.80.80.17	13.58	3.15	1.26	0.67	15.75	14.84	2.76	3.15	Bronze	68
SEF.345.80.80.15	13.58	3.15	1.10	0.59	15.75	14.69	2.95	3.15	Bronze	70
SEF.390.55.70.15	15.35	2.17	1.10	0.59	17.72	16.46	2.36	2.76	Bronze	79
SEF.390.60.70.16	15.35	2.36	1.10	0.63	17.72	16.46	2.36	2.76	Bronze	70
SEF.390.70.70.16	15.35	2.76	1.18	0.63	17.72	16.54	2.36	2.76	Bronze	69
SEF.390.70.70.15	15.35	2.76	1.10	0.59	17.72	16.46	2.36	2.76	Bronze	70
SEF.390.80.80.20	15.35	3.15	1.50	0.79	17.72	16.85	2.76	3.15	Bronze	88
SEF.390.80.80.19	15.35	3.15	1.42	0.75	17.72	16.77	2.76	3.15	Bronze	88
SEF.390.80.80.17	15.35	3.15	1.26	0.67	17.72	16.61	2.76	3.15	Bronze	90
SEF.390.80.85.19,5	15.35	3.15	1.46	0.77	17.72	16.81	2.95	3.35	Bronze	92
SEF.390.80.85.17	15.35	3.15	1.26	0.67	17.72	16.61	2.95	3.35	Bronze	106
SEF.390.90.85.19,5	15.35	3.54	1.46	0.77	17.72	16.81	2.95	3.35	Bronze	89
SEF.430.60.80.16	16.93	2.36	1.18	0.63	19.69	18.11	2.76	3.15	Bronze	97
SEF.430.80.80.20	16.93	3.15	1.50	0.79	19.49	18.43	2.76	3.15	Bronze	95
SEF.430.80.80.17	16.93	3.15	1.26	0.67	19.49	18.19	2.76	3.15	Bronze	97
SEF.430.100.80.20	16.93	3.94	1.50	0.79	19.49	18.43	2.76	3.15	Bronze	92
SEF.430.100.80.17	16.93	3.94	1.26	0.67	19.49	18.19	2.76	3.15	Bronze	95
SEF.430.100.100.19,5	16.93	3.94	1.46	0.77	19.69	18.39	3.54	3.94	Bronze	176
SEF.480.70.80.18	18.90	2.76	1.34	0.71	21.65	20.24	2.76	3.15	Bronze	115
SEF.480.120.120.21,5	18.90	4.72	1.57	0.85	21.65	20.47	3.94	4.72	Bronze	176
SEF.520.80.105.19,5	20.47	3.15	1.46	0.77	23.62	21.93	3.35	4.13	Bronze	176
SEF.520.120.90.27,5	20.47	4.72	2.05	1.08	23.43	22.52	3.15	3.54	Bronze	140
SEF.520.120.80.17	20.47	4.72	1.26	0.67	23.43	21.73	2.76	3.15	Bronze	141
SEF.520.120.90.23,5	20.47	4.72	1.73	0.93	23.43	22.20	3.15	3.54	Bronze	145
SEF.520.120.90.20	20.47	4.72	1.50	0.79	23.43	21.97	3.15	3.54	Bronze	149
SEF.560.100.110.20,5	22.05	3.94	1.54	0.81	26.18	23.58	3.94	4.33	Bronze	242
SEF.630.120.110.21,5	24.80	4.72	1.57	0.85	27.95	26.38	3.35	4.33	Bronze	252
SEF.710.150.130.23,5	27.95	5.91	1.73	0.93	31.89	29.69	3.86	5.12	Bronze	374
SEF.800.150.150.22	31.50	5.91	1.73	0.87	36.22	33.23	5.12	5.91	Bronze	594
SEF.920.160.150.22	36.22	6.30	1.61	0.87	40.55	37.83	5.12	5.91	Bronze	836
SEF.1020.180.160.24,5	40.16	7.09	1.81	0.96	45.67	41.97	5.51	6.30	Bronze	1188

- Different shaft sizes possible.
- Groove may be adjusted to other wire rope diameters.



SEE OUR WARNING & SAFETY INFORMATION ON PAGES 136 - 149





PLASTIC SHEAVES

Made fully out of Polyamid, plastic wire rope sheaves are the most lightweight sheaves in the Ropeblock portfolio. They come in many sizes, up to approx. 1000 mm (for larger diameters a hybrid solution can be considered). Plastic sheaves are cost efficient and usually available from stock.

**PLEASE NOTE THAT PLASTIC SHEAVES
ARE NOT SUITABLE FOR ALL CONDITIONS.
WE WILL BE HAPPY TO ADVISE.**



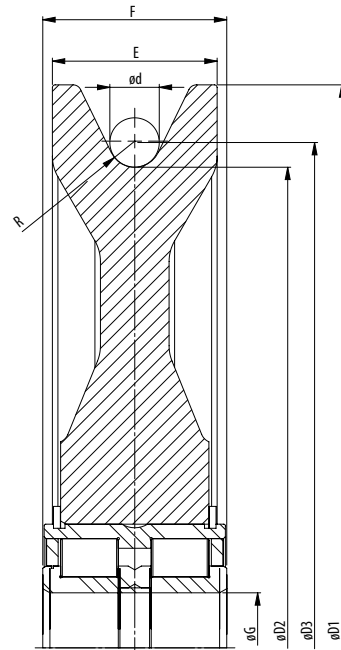

Model No.	Dimensions (inch)								Bearing	Weight (lbs)
	Sheave tread ø	Shaft ø	For wire ød	Groove radius	Outer ø	P.C.D.	Rim width	Bearing width		
	øD2	øG	d	R	øD1	øD3	E	F		
SE.260.5010.6,5.K	10.24	1.97	0.47	0.26	11.81	10.71	1.34	1.57	SL04 5010PP	6
SE.285.5012.6,5.K	11.22	2.36	0.47	0.26	12.80	11.69	1.34	1.81	SL04 5012PP	9
SE.350.5014.14.K	13.78	2.76	1.02	0.55	16.38	14.80	2.05	2.13	SL04 5014PP	13
SE.352.5013.9,5.K	13.86	2.56	0.67	0.37	15.75	14.53	1.65	1.81	SL04 5013PP	12
SE.352.5013.8,5.K	13.86	2.56	0.63	0.33	15.75	14.49	1.65	1.81	SL04 5013PP	12
SE.352.5016.8,5.K	13.86	3.15	0.63	0.33	15.75	14.49	1.97	2.36	SL04 5016PP	17
SE.400.5018.10,5.K	15.75	3.54	0.75	0.41	18.11	16.50	2.36	2.64	SL04 5018PP	22
SE.400.5018.10.K	15.75	3.54	0.71	0.39	18.11	16.46	2.36	2.64	SL04 5018PP	24
SE.400.5024.10.K	15.75	4.72	0.71	0.39	18.11	16.46	2.83	3.15	SL04 5024PP	31
SE.400.160.10.K	15.75	6.30	0.71	0.39	18.11	16.46	2.83	3.15	SL04 160PP	30
SE.482.5018.12.K	18.98	3.54	0.87	0.47	21.97	19.84	2.44	2.64	SL04 5018PP	29
SE.482.5018.11,5.K	18.98	3.54	0.83	0.45	22.05	19.80	2.44	2.64	SL04 5018PP	31
SE.482.5024.11,5.K	18.98	4.72	0.83	0.45	22.05	19.80	2.83	3.15	SL04 5024PP	39
SE.482.160.11,5.K	18.98	6.30	0.83	0.45	22.05	19.80	2.83	3.15	SL04 160PP	38
SE.528.5018.14.K	20.79	3.54	1.02	0.55	23.46	21.81	2.44	2.64	SL04 5018PP	33
SE.528.5018.12.K	20.79	3.54	0.87	0.47	23.46	21.65	2.36	2.64	SL04 5018PP	33
SE.528.5018.13.K	20.79	3.54	0.94	0.51	23.46	21.73	2.44	2.64	SL04 5018PP	33
SE.528.5018.8,5.K	20.79	3.54	0.63	0.33	23.46	21.42	2.44	2.64	SL04 5018PP	34
SE.528.5024.13.K	20.79	4.72	0.94	0.51	23.46	21.73	2.83	3.15	SL04 5024PP	46
SE.528.160.13.K	20.79	4.72	0.94	0.51	23.46	21.73	2.83	3.15	SL04 160PP	49
SE.630.160.15,5.K	24.80	6.30	1.10	0.61	27.95	25.91	2.95	3.15	SL04 160PP	62
SE.662.5026.15,5.K	26.06	5.12	1.10	0.61	29.21	27.17	3.15	3.74	SL04 5026PP	76
SE.772.5026.15,5.K	30.39	5.12	1.10	0.61	33.54	31.50	3.15	3.74	SL04 5026PP	101

- The dimensions in this table are indicative only. A drawing will always be submitted prior to production and will be the leading document when discussing dimensions.
- Sheaves shown here are standard models; inquiries for custom versions are welcome.

 SEE OUR WARNING & SAFETY INFORMATION ON PAGES 136 - 149





WELDED SHEAVES

Ropeblock welded steel sheaves are available in a range of standard models. However, it's in more customized solutions that this type of sheave really comes into its own.

Examples include applications with unusual axle sizes and/or extremely large diameters, where timing is also a key factor.



SOLID SHEAVES

Ropeblock sheaves from solid materials make for quick solutions. As we manufacture these sheaves in a simple yet highly efficient process, we can supply them quickly and in many different sizes.

Solid steel wire rope sheaves, especially, offer plenty of room for customization in terms of sizes, materials and bearing systems.



FORGED SHEAVES

Although the material properties of forged sheaves can be very similar to those of other materials, this type of sheave can be a very adequate choice for specific applications.

AVAILABLE FINISHES (DEPENDS ON THE APPLICATION)

Segment / application	ISO 12944 classification	Classification description	Expected protection duration	DFT (µm)
Construction	C2M	Slightly polluted atmosphere, predominately agriculture areas	5 to 15 year	120
Construction	C3M	Industrial and residential air pollution levels, with an average sulfur dioxide (IV) contamination level. Coastal areas with low salt content in air	2 to 5 year	120
Construction	C3M	Industrial and residential air pollution levels, with an average sulfur dioxide (IV) contamination level. Coastal areas with low salt content in air	5 to 15 year	160
Cargo handling	C3M	Industrial and residential air pollution levels, with an average sulfur dioxide (IV) contamination level. Coastal areas with low salt content in air	5 to 15 year	160
Cargo handling	C4H	Industrial areas and coastal areas with average salt content in air	more than 15 year	280
Cargo handling	C5-MM	Coastal areas and open sea with high salt content in air	5 to 15 year	280
Offshore	C4H	Industrial areas and coastal areas with average salt content in air	more than 15 year	300
Offshore	C5-MM	Coastal areas and open sea with high salt content in air	5 to 15 year	300
Offshore	C5-MH	Coastal areas and open sea with high salt content in air	more than 15 year	320
Offshore	NORSOK sys. 1*	Open sea with high salt content in air	more than 15 year	300



SEE OUR WARNING & SAFETY INFORMATION ON PAGES 136 - 149





API SHEAVES

IMPROVED EFFICIENCY, DURABILITY AND SAFETY

Based on abundant experience with sheaves in various blocks and applications, Ropeblock developed API sheaves.

Besides the presented list for our standard sheaves, custom-made sheaves are often an optimum solution, since line pull, fleet angles and other specifications may vary.

The sheaves are weldless designed with smooth transitions and manufactured, machined and material treated with greatest care.

Characteristics include:

- Standard sheave diameter range from 26" to 82"
- Standard wire sizes 9/16" to 3"
- Meets API 8C specifications
- Unrivalled weight / fatigue performance ratio
- Groove hardness minimum 35 HRC
- Balanced
- Tapered rolling bearings, size selected to fit the application
- Other bearing types available on request
- Finish in accordance with C5-MM, C5-MH (ISO 12944) or NORSOK system 1
- Custom designs possible

Sheave Outside ø	Sheave Outside ø (mm)	Wire size range ø (inch)	Wire size range ø (mm)	Shaft ø (inch)	Shaft ø (mm)
24"	609,6	5/16 - 1	14 - 25	4 1/4	107,95
30"	762,0	1 - 1 1/8	25 - 29	5 3/8	142,88
36"	914,4	1 - 1 3/8	25 - 35	6 1/2	165,10
42"	1066,8	1 1/8 - 1 1/2	29 - 38	8	203,20
50"	1270,0	1 1/4 - 1 1/2	32 - 38	8	203,20
52"	1320,8	1 3/8 - 1 1/2	35 - 38	8	203,20
55"	1397,0	1 3/8 - 1 3/4	35 - 44	9 1/4	234,95
60"	1524,0	1 1/2 - 2 1/8	35 - 54	10 1/2	266,70
68"	1727,2	1 1/2 - 2 1/8	38 - 54	10 1/2	304,8
72"	1828,8	1 3/4 - 2 1/8	44 - 54	14	355,60
78"	1981,2	1 3/4 - 3	44 - 76	14	355,60
82"	2082,8	1 3/4 - 3	44 - 76	14	355,60

SEE OUR WARNING AND SAFETY INFORMATION ON PAGE 136



SEE OUR WARNING & SAFETY INFORMATION ON PAGES 136 - 149



SOCKETS

The Ropeblock Socket range consists of sockets to be used with both general purpose and high performance ropes. These sockets are used in extreme environments for dredging, mining, arctic and subsea applications.

Besides the standard range shown in this catalogue, Ropeblock can design, engineer and manufacture any special socket solution that a certain application might require.



DISTRIBUTION

Ropeblock has a strong global network of stocking distributors. As a result end-users as well as OEMs are assured of immediate socket availability.

DESIGN

Spelter socket loading mechanisms are highly complex. True and full understanding of the non-linear behavior involved is required when aiming for the engineering optimum. That's why Ropeblock conducted extensive research in this area, using strain gauge testing and Finite Element Method (FEM) techniques. We achieved abovementioned optimum in geometry with our market-first anti-rotation and negative force nose and low notch-factor design for improved fatigue service. Ropeblock OSS, CSS and SBS Sockets are type approved by DNV and LRS.

MATERIALS

The Ropeblock standard socket range is available in quenched and tempered cast steel with mechanical properties to meet today's tough market requirements. All sockets are suitable for use in sub-zero temperature environments. Materials meet or exceed an impact value of > 42 Joule / -20°C Charpy-V. Each Ropeblock socket is visibly marked with its size, wire rope diameter and batch or serial number. All individual parts can be traced back to their original certificates by the batch or serial number to be found on each component.

TESTING

Ropeblock sockets are subject to the most stringent surface and volumetric NDT procedures, excluding any risk for manufacturing flaws. Said procedures are accepted by all large third party authorities.

Sockets can be individually proof tested on request. The default proof load value is 40% of the catalog MBL for spelter sockets and 30% for wedge sockets. Higher values until 50% will require special consideration and is strongly advised against.

In-house access to a vertical socket test bed, as well as a horizontal general purpose test bed, is available to ensure fast reaction time. Custom designed testing tools have been developed to test all elements, including the basket.

FINISH

All Wedge, Spelter and Fast and Super Reeve Connector Sockets are finished with a primer in Ropeblock blue, or a hot dip galvanized finish.

SPECIAL REQUIREMENTS

Our engineers will gladly meet any special requirements you may have. Advanced 3D CAD and Finite Element Method (FEM) techniques decrease the time-to-market of new innovative socket designs. These designs include the use of different materials (e.g. stainless steel), advanced features (e.g. swivel socket), and special aesthetics (e.g. for bridge work).

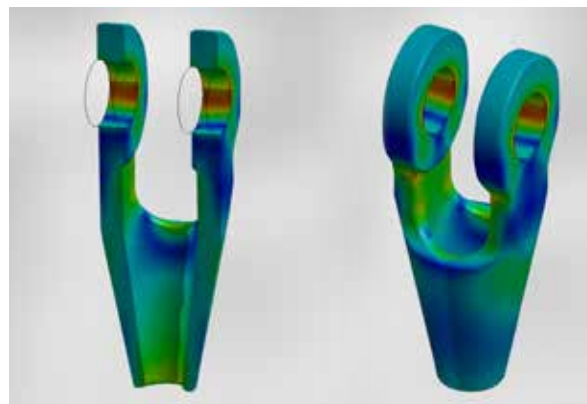



CERTIFICATES & DOCUMENTS

Ropeblock products are available with all types of applicable certifications, ranging from a basic ILO-3 certificate to third-party design approvals and witnessed proof loading certificates. All Ropeblock Spelter Sockets (types OSS, CSS and SBS) come with DNV and Lloyd's Register type approval. In addition, depending on the product type, Ropeblock products can be supplied with any of the following documents:

- Declaration of compliance to EN 10204-2.1, stating:
 - Certificate number
 - Wire rope diameter
 - Minimum breaking load (MBL)
 - Quantity
 - Order number
- Declaration of compliance to EN 10204-2.2, stating:
 - Working Load Limit (WLL)
 - Weight
 - Order number
 - Proof load in kN
 - Serial number
- Material certificate in accordance with EN 10204-3.1 or EN 10204-3.2.
- Manufacturer test certificate in accordance with ILO convention No. 152
- NDE inspection reports (magnetic and ultrasonic testing)
- Witness or survey certificate issued by official classification or inspection agencies, all IASC agencies accepted (e.g. ABS, DNV, LRS)
- Third Party design or type approval
- Third Party product certificate
- Full Manufacturing Record Book, including material certificates, test certificates, welding log, paint log, etc.
- EC Declaration in accordance with Machine Directive 2006/42/EG (where applicable)

INSPECTION CERTIFICATES ISSUED BY OFFICIAL CLASSIFICATION OR INSPECTION AGENCIES ARE AVAILABLE ON REQUEST.

PLEASE NOTE THAT THE ABOVE IS AN ABSTRACT OF WHAT IS COMMONLY REQUESTED, BUT NOT CONSIDERED STANDARD. FEEL FREE TO CONTACT US FOR DETAILS.



SOCKETS OVERVIEW



OPEN SPELTER SOCKETS

Quenched and tempered cast steel range with mechanical values (Charpy-V > 42 Joule / -20°C) for tough and low temperature use. For wire rope diameter 6 - 204 mm (1/4" - 8"). Pin secured by cotter pin or bolt, nut and cotter. Optional is a flange connection for use with a bend stiffener. All spelter sockets have a 100% efficiency on wire rope MBL.

PAGE 88



CLOSED SPELTER SOCKETS

Quenched and tempered cast steel range with mechanical values (Charpy-V > 42 Joule / -20°C) for tough and low temperature use. For wire rope diameter 6 - 204 mm (1/4" - 8"). All spelter sockets have a 100% efficiency on wire rope MBL.

PAGE 90



SHORT BOW SOCKETS

The 'ultimate' socket for dynamic loads. Towing lines, anchor lines and chain-rope connections used by major offshore contractors. Quenched and tempered cast steel with extremely high mechanical values for an unmatched weight to MBL ratio. All spelter sockets have a 100% efficiency on wire rope MBL.

PAGE 91



FAST CONNECTOR SOCKETS

Specifically designed for mobile and crawler cranes as an alternative to wedge sockets, but with the benefit of 100% efficiency on the wire rope MBL. This socket meets the respective EN standards.

PAGE 92



SUPER REEVE CONNECTOR SOCKETS

A revolutionary evolution of the Fast Connector Socket. This socket line has the smallest connector diameter available in the market today, and still meets the respective EN standards. It has been designed to go through the smallest spaces in a crane reeving system. This unique patented design allows refitting by pouring in the field, saving valuable down time compared to swaging techniques.

PAGE 94





moet hier
geen 'new'
bij staan?

is dit nog
steeds
'nieuw'?

NEW



**SUPER REEVE
CONNECTOR
SWIVEL SOCKETS**

A revolutionary evolution of the Fast Connector Socket. This socket line has the smallest connector diameter available in the market today, and still meets the respective EN standards. It has been designed to go through the smallest spaces in a crane reeving system. This unique patented design allows refitting by pouring in the field, saving valuable down time compared to swaging techniques.

PAGE 96



**OPEN WEDGE
SOCKETS**

Quick detachable socket range for wire rope diameter 7 - 86 mm ($\frac{5}{16}$ " - $3\frac{3}{8}$ "). Basket and wedge in quenched and tempered cast steel. Wedge and basket are designed for easy installation and optimal wire rope efficiency.

PAGE 98



**TAILGRIP OPEN
WEDGE SOCKETS**

Quick detachable socket range for wire rope diameter 9 - 32 mm ($\frac{3}{8}$ " - $1\frac{1}{4}$ "). Basket and wedge in quenched and tempered cast steel. Wedge, basket and clip are designed for easy installation and optimal wire rope efficiency.

PAGE 100



**CLOSED WEDGE
SOCKETS**

Quick detachable socket range for wire rope diameter 18 - 86 mm ($\frac{3}{4}$ " - $3\frac{1}{4}$ "). Basket and wedge in quenched and tempered cast steel. Wedge and basket are designed for easy installation and optimal wire rope efficiency.

PAGE 102



**PORT INDUSTRY
SOCKETS**

Quenched and tempered cast steel range with mechanical values (Charpy-V > 42 Joule / -20°C) for tough and low temperature use. For wire rope diameter 28 – 60 mm ($1\frac{1}{8}$ " – $2\frac{1}{2}$ "). Pin secured by cotter pin or bolt, nut and cotter. Optional is a flange connection for use with a bend stiffener. All spelter sockets have a 100% efficiency on wire rope MBL.

PAGE 104



OPEN SPELTER SOCKETS WITH PIN

QUENCHED AND
TEMPERED CAST STEEL

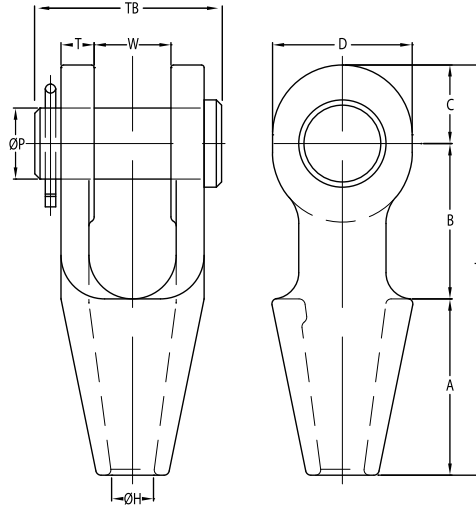

Model No.	MBL (UStons)	for wire ø		Strand ø		Dimensions (inch)										Weight (lbs)
		(mm)	(inch)	(mm)	(inch)	A	B	C	D	øH	øP	T	TL	TB	W	
OSS 196 P	9	6-7	¼	-	-	1.97	1.57	0.75	1.34	0.36	0.63	0.35	4.29	2.01	0.75	0.9
OSS 197 P	13	8-10	⅜	-	-	2.24	1.77	0.87	1.65	0.49	0.79	0.43	4.88	2.48	0.83	1.5
OSS 198 P	22	11-13	7/16 - ½	-	-	2.50	2.01	1.06	1.97	0.57	0.98	0.46	5.57	2.64	1.00	2.2
OSS 199 P	28	14-16	9/16 - 5/8	13	½	2.99	2.48	1.26	2.28	0.71	1.18	0.55	6.73	3.35	1.26	4.0
OSS 100 P	44	18-19	¾	14 - 16	9/16 - 5/8	3.50	2.99	1.57	2.76	0.86	1.38	0.63	8.07	3.74	1.50	7
OSS 104 P	61	20-22	7/8	18 - 19	¾	3.98	3.50	1.77	3.15	0.98	1.61	0.75	9.25	4.33	1.73	10
OSS 108 P	83	23-26	1	20 - 22	7/8	4.49	3.98	2.36	4.09	1.13	2.01	0.87	10.83	5.04	2.01	18
OSS 111 P	99	27-30	1 1/8	23 - 26	1	5.00	4.49	2.56	4.49	1.29	2.24	0.98	12.05	5.59	2.24	24
OSS 115 P	138	31-36	1 1/4 - 1 3/8	27 - 28	1 1/16 - 1 1/8	5.47	5.00	2.83	4.96	1.54	2.48	1.10	13.31	6.10	2.48	34
OSS 118 P	165	37-39	1 1/2	30 - 32	1 3/16 - 1 1/4	5.98	6.38	3.15	5.59	1.67	2.76	1.18	15.51	6.97	2.99	48
OSS 120 P	187	40-42	1 5/8	33 - 35	1 9/16 - 1 3/8	6.50	6.50	3.46	6.14	1.79	2.99	1.30	16.46	7.36	2.99	60
OSS 125 P	248	43-48	1 3/4 - 1 7/8	36 - 40	1 7/16 - 1 5/8	7.52	7.01	3.94	6.93	2.06	3.50	1.54	18.46	8.46	3.50	90
OSS 128 P	309	49-54	2 - 2 1/8	42 - 45	1 5/8 - 1 3/4	8.50	8.98	4.25	7.64	2.32	3.74	1.77	21.73	9.61	3.98	132
OSS 130 P	397	55-60	2 1/4 - 2 3/8	46 - 48	1 13/16 - 1 7/8	9.02	10.00	4.72	8.27	2.54	4.25	2.09	23.74	10.83	4.45	194
OSS 132 P	468	61-68	2 1/2 - 2 5/8	50 - 54	2 - 2 1/8	9.76	10.75	5.24	9.29	2.96	4.76	2.36	25.75	11.81	5.00	261
OSS 135 P	507	69-75	2 3/4 - 2 7/8	56 - 62	2 1/4 - 2 1/2	10.98	10.98	5.43	9.45	3.20	5.00	2.87	27.40	13.19	5.24	342
OSS 138 P	617	76-80	3 - 3 1/8	64 - 67	2 1/2 - 2 5/8	12.01	11.26	5.75	9.92	3.47	5.24	2.99	29.02	13.98	5.75	410
OSS 140 P	689	81-86	3 1/4 - 3 3/8	69 - 76	2 3/4 - 3	12.99	11.73	6.30	11.42	3.63	5.51	3.11	31.02	14.76	6.26	499
OSS 142 P	794	87-93	3 1/2 - 3 5/8	78 - 86	3 1/16 - 3 3/8	14.02	12.52	6.99	12.60	3.91	5.98	3.27	33.52	15.75	6.73	624
OSS 144 P	965	94-102	3 3/4 - 4	88 - 96	3 7/16 - 3 3/4	15.00	13.50	7.48	13.78	4.24	7.01	3.50	35.98	17.13	7.52	825
OSS 146 P	1323	108-115	4 1/4 - 4 1/2	98 - 110	3 7/8 - 4 5/16	17.72	18.90	8.46	15.75	5.09	7.68	3.94	45.08	18.31	8.07	1188
OSS 150 P	1543	120-130	4 3/4 - 5	112 - 124	4 7/16 - 4 7/8	19.69	19.69	9.84	17.72	5.78	8.66	4.33	49.21	20.67	8.86	1678
OSS 155 P	1764	135-140	5 1/4 - 5 1/2	125 - 132	4 15/16 - 5 3/16	21.26	19.57	10.35	18.90	6.06	9.45	5.51	51.18	23.23	9.06	2352
OSS 160 P	2205	142-153	5 3/4 - 6	133 - 143	5 1/4 - 5 5/8	23.03	19.88	10.83	19.69	6.73	10.04	5.51	53.74	24.02	9.84	2584
OSS 165 P	2447	154-165	6 1/4 - 6 1/2	144 - 154	5 11/16 - 6 1/4	24.80	20.87	11.81	21.65	7.28	10.83	5.91	57.48	25.20	10.24	3177
OSS 170 P	2756	166-178	6 3/4 - 7	155 - 166	6 1/4 - 6 3/4	26.77	22.44	12.20	22.44	7.83	11.61	5.91	61.42	25.98	11.02	3560
OSS 175 P	3086	180-191	7 1/4 - 7 1/2	167 - 179	6 9/16 - 7 1/16	28.54	23.62	12.80	23.62	8.39	12.20	6.10	64.96	27.13	11.81	4204
OSS 180 P	3527	192-204	7 3/4 - 8	180 - 191	7 1/4 - 7 1/2	30.51	24.41	13.58	25.20	9.02	12.99	6.30	68.50	28.35	12.60	4936

MBL = Minimum Breaking Load

- The standard finish of the sockets is blue primer coating and hot dipped galvanized (OSS 196 until OSS 100 only galvanized)
- All sockets are provided with an EN 10204-2.1 declaration of conformity and EN 10204-3.1 material certificate.
- Dimensional tolerances are ±5% for the jaw opening (W) and pin diameter (øP).
- For other dimensional tolerances please contact Ropeblock.
- Surface finish e.g. hot dip galvanizing or paint may add to the overall thickness and fork distance.



OPEN SPELTER SOCKETS WITH BOLT AND NUT

**QUENCHED AND
TEMPERED CAST STEEL**

SOCKETS

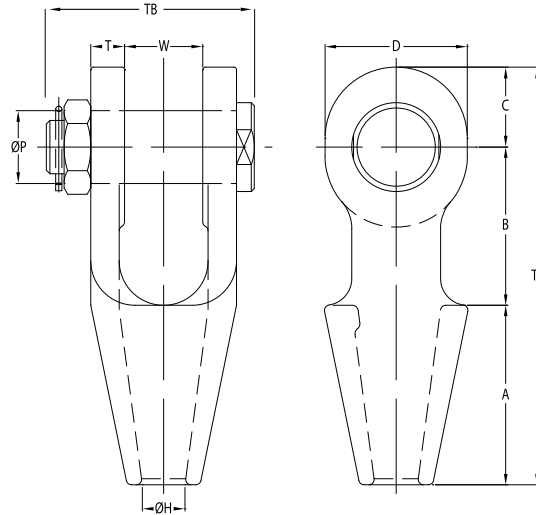

Model No.	MBL (UStons)	for wire ø		Strand ø		Dimensions (inch)										Weight (lbs)
		(mm)	(inch)	(mm)	(inch)	A	B	C	D	øH	øP	T	TL	TB	W	
OSS 196 B	9	6-7	¼	-	-	1.97	1.57	0.75	1.34	0.36	0.63	0.35	4.29	2.44	0.75	1.1
OSS 197 B	13	8-10	⅜	-	-	2.24	1.77	0.87	1.65	0.49	0.79	0.43	4.88	2.95	0.83	1.7
OSS 198 B	22	11-13	7/16 - ½	-	-	2.50	2.01	1.06	1.97	0.57	0.98	0.46	5.57	3.15	1.00	2.4
OSS 199 B	28	14-16	9/16 - 5/8	13	½	2.99	2.48	1.26	2.28	0.71	1.18	0.55	6.73	3.78	1.26	4.2
OSS 100 B	44	18-19	¾	14 - 16	9/16 - 5/8	3.50	2.99	1.57	2.76	0.86	1.38	0.63	8.07	4.21	1.50	7
OSS 104 B	61	20-22	7/8	18 - 19	¾	3.98	3.50	1.77	3.15	0.98	1.61	0.75	9.25	4.84	1.73	10
OSS 108 B	83	23-26	1	20 - 22	7/8	4.49	3.98	2.36	4.09	1.13	2.01	0.87	10.83	5.43	2.01	18
OSS 111 B	99	27-30	1 1/8	23 - 26	1	5.00	4.49	2.56	4.49	1.29	2.24	0.98	12.05	6.30	2.24	26
OSS 115 B	138	31-36	1 1/4 - 1 3/8	27 - 28	1 1/16 - 1 1/8	5.47	5.00	2.83	4.96	1.54	2.48	1.10	13.31	6.50	2.48	35
OSS 118 B	165	37-39	1 1/2	30 - 32	1 3/16 - 1 1/4	5.98	6.38	3.15	5.59	1.67	2.76	1.18	15.51	7.83	2.99	50
OSS 120 B	187	40-42	1 5/8	33 - 35	1 3/8 - 1 3/4	6.50	6.50	3.46	6.14	1.79	2.99	1.30	16.46	8.23	2.99	62
OSS 125 B	248	43-48	1 3/4 - 1 7/8	36 - 40	1 7/16 - 1 5/8	7.52	7.01	3.94	6.93	2.06	3.50	1.54	18.46	9.33	3.50	95
OSS 128 B	309	49-54	2 - 2 1/8	42 - 45	1 5/8 - 1 3/4	8.50	8.98	4.25	7.64	2.32	3.74	1.77	21.73	10.35	3.98	136
OSS 130 B	397	55-60	2 1/4 - 2 3/8	46 - 48	1 13/16 - 1 7/8	9.02	10.00	4.72	8.27	2.54	4.25	2.09	23.74	11.73	4.45	199
OSS 132 B	468	61-68	2 1/2 - 2 5/8	50 - 54	2 - 2 1/8	9.76	10.75	5.24	9.29	2.96	4.76	2.36	25.75	12.99	5.00	270
OSS 135 B	507	69-75	2 3/4 - 2 7/8	56 - 62	2 1/4 - 2 1/2	10.98	10.98	5.43	9.45	3.20	5.00	2.87	27.40	14.13	5.24	350
OSS 138 B	617	76-80	3 - 3 1/8	64 - 67	2 1/2 - 2 5/8	12.01	11.26	5.75	9.92	3.47	5.24	2.99	29.02	14.96	5.75	419
OSS 140 B	689	81-86	3 1/4 - 3 3/8	69 - 76	2 3/4 - 3	12.99	11.73	6.30	11.42	3.63	5.51	3.11	31.02	15.63	6.26	507
OSS 142 B	794	87-93	3 1/2 - 3 5/8	78 - 86	3 1/8 - 3 3/8	14.02	12.52	6.99	12.60	3.91	5.98	3.27	33.52	16.50	6.73	632
OSS 144 B	965	94-102	3 3/4 - 4	88 - 96	3 7/16 - 3 3/4	15.00	13.50	7.48	13.78	4.24	7.01	3.50	35.98	17.76	7.52	831
OSS 146 B	1323	108-115	4 1/4 - 4 1/2	98 - 110	3 7/8 - 4 5/16	17.72	18.90	8.46	15.75	5.09	7.68	3.94	45.08	19.92	8.07	1207
OSS 150 B	1543	120-130	4 3/4 - 5	112 - 124	4 7/16 - 4 7/8	19.69	19.69	9.84	17.72	5.78	8.66	4.33	49.21	21.50	8.86	1688
OSS 155 B	1764	135-140	5 1/4 - 5 1/2	125 - 132	4 15/16 - 5 3/16	21.26	19.57	10.35	18.90	6.06	9.45	5.51	51.18	24.53	9.06	2383
OSS 160 B	2205	142-153	5 3/4 - 6	133 - 143	5 1/4 - 5 5/8	23.03	19.88	10.83	19.69	6.73	10.04	5.51	53.74	25.79	9.84	2646
OSS 165 B	2447	154-165	6 1/4 - 6 1/2	144 - 154	5 11/16 - 6 1/4	24.80	20.87	11.81	21.65	7.28	10.83	5.91	57.48	26.97	10.24	3250
OSS 170 B	2756	166-178	6 3/4 - 7	155 - 166	6 1/4 - 6 3/4	26.77	22.44	12.20	22.44	7.83	11.61	5.91	61.42	28.15	11.02	3649
OSS 175 B	3086	180-191	7 1/4 - 7 1/2	167 - 179	6 9/16 - 7 1/16	28.54	23.62	12.80	23.62	8.39	12.20	6.10	64.96	29.53	11.81	4312
OSS 180 B	3527	192-204	7 3/4 - 8	180 - 191	7 1/4 - 7 1/2	30.51	24.41	13.58	25.20	9.02	12.99	6.30	68.50	31.10	12.60	5077

MBL = Minimum Breaking Load

- The standard finish of the sockets is blue primer coating and hot dipped galvanized (OSS 196 until OSS 100 only galvanized)
- All sockets are provided with an EN 10204-2.1 declaration of conformity and EN 10204-3.1 material certificate.
- Dimensional tolerances are ±5% for the jaw opening (W) and pin diameter (øP).
- For other dimensional tolerances please contact Ropeblock.
- Surface finish e.g. hot dip galvanizing or paint may add to the overall thickness and fork distance.



SEE OUR WARNING AND SAFETY INFORMATION ON PAGE 136



CLOSED SPELTER SOCKETS

QUENCHED AND TEMPERED CAST STEEL

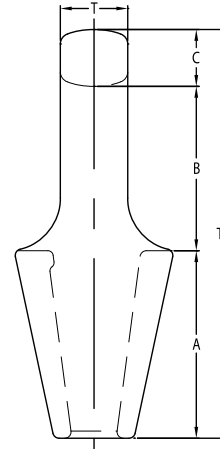
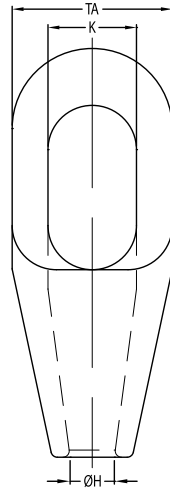

Model No.	MBL (UStons)	for wire ø		Strand ø		Dimensions (inch)								Weight (lbs)
		(mm)	(inch)	(mm)	(inch)	A	B	C	øH	K	T	TA	TL	
CSS 296	9	6-7	¼	-	-	1.97	1.57	0.43	0.36	0.87	0.51	1.46	3.98	1
CSS 297	13	8-10	⅜	-	-	2.24	1.89	0.55	0.50	0.98	0.69	1.69	4.69	1
CSS 298	22	11-13	7/16 - ½	-	-	2.50	2.32	0.69	0.57	1.18	0.89	2.01	5.51	2
CSS 299	28	14-16	9/16 - 5/8	13	½	2.99	2.56	0.83	0.71	1.42	1.02	2.64	6.38	3
CSS 200	44	18-19	¾	14 - 16	9/16 - 5/8	3.50	3.07	1.06	0.86	1.65	1.26	2.99	7.64	5
CSS 201	61	20-22	7/8	18 - 19	¾	3.98	3.54	1.30	0.98	1.85	1.50	3.62	8.82	8
CSS 204	83	23-26	1	20 - 22	7/8	4.49	4.06	1.42	1.13	2.24	1.73	4.09	9.96	12
CSS 207	99	27-30	1 ⅛	23 - 26	1	5.00	4.57	1.54	1.30	2.56	2.01	4.49	11.10	16
CSS 212	138	31-36	1 ¼ - 1 ⅜	27 - 28	1 1/16 - 1 1/8	5.47	5.12	1.69	1.54	2.80	2.24	4.96	12.28	22
CSS 215	165	37-39	1 ½	30 - 32	1 3/16 - 1 ¼	5.98	6.10	2.01	1.67	3.19	2.48	5.35	14.09	29
CSS 217	187	40-42	1 ⅝	33 - 35	1 5/16 - 1 3/8	6.50	6.73	2.13	1.79	3.27	2.76	5.75	15.35	37
CSS 219	248	43-48	1 ¾ - 1 7/8	36 - 40	1 7/16 - 1 5/8	7.48	7.80	2.17	2.07	3.66	2.99	6.73	17.44	56
CSS 222	309	49-54	2 - 2 1/8	42 - 45	1 5/8 - 1 3/4	8.50	8.82	2.44	2.33	3.94	3.23	7.60	19.76	81
CSS 224	397	55-60	2 ¼ - 2 3/8	46 - 48	1 13/16 - 1 7/8	8.98	9.72	2.87	2.56	4.41	3.62	8.50	21.57	111
CSS 226	468	61-68	2 ½ - 2 5/8	50 - 54	2 - 2 1/8	9.76	10.63	3.11	2.95	5.51	4.02	9.49	23.50	144
CSS 227	507	69-75	2 3/4 - 2 7/8	56 - 62	2 ¼ - 2 ½	10.98	11.26	3.11	3.13	6.26	4.88	10.75	25.35	201
CSS 228	617	76-80	3 - 3 1/8	64 - 67	2 ½ - 2 5/8	12.40	11.73	3.27	3.47	6.73	5.24	11.50	27.40	257
CSS 229	689	81-86	3 ¼ - 3 3/8	69 - 76	2 3/4 - 3	12.99	12.24	4.02	3.64	7.24	5.75	12.24	29.25	274
CSS 230	794	87-93	3 ½ - 3 5/8	78 - 86	3 1/16 - 3 3/8	14.02	12.99	4.02	3.89	7.76	6.26	12.99	31.02	388
CSS 231	965	94-102	3 ¾ - 4	88 - 96	3 7/16 - 3 ¾	15.00	14.02	4.25	4.24	8.50	7.01	14.25	33.27	502
CSS 233	1323	108-115	4 ¼ - 4 ½	98 - 110	3 7/8 - 4 5/16	17.72	16.73	4.92	5.10	9.25	7.48	15.94	39.37	712
CSS 240	1543	120-130	4 ¾ - 5	112 - 124	4 7/16 - 4 7/8	19.69	20.67	4.92	5.79	10.24	7.87	17.72	45.28	986
CSS 245	1764	135-140	5 ¼ - 5 ½	125 - 132	4 15/16 - 5 3/16	21.26	19.49	5.91	6.07	11.42	8.66	20.47	46.65	1422
CSS 250	2205	142-153	5 ¾ - 6	133 - 143	5 ¼ - 5 5/8	23.03	20.87	6.69	6.74	12.01	9.45	21.46	50.59	1634
CSS 255	2447	154-165	6 ½ - 6 ¼	144 - 154	5 11/16 - 6 ¼	24.80	22.24	6.89	7.29	12.99	9.84	22.64	53.94	1896
CSS 260	2756	166-178	6 ¾ - 7	155 - 166	6 ¼ - 6 ¾	26.77	23.23	7.09	7.84	12.99	10.63	23.43	57.09	2172
CSS 265	3086	180-191	7 ¼ - 7 ½	167 - 179	6 5/16 - 7 1/16	28.54	24.41	7.48	8.39	13.78	11.42	24.61	60.43	2608
CSS 270	3527	192-204	7 ¾ - 8	180 - 191	7 ¼ - 7 ½	30.51	25.59	8.27	9.00	15.55	12.01	27.17	64.37	3278

MBL = Minimum Breaking Load

- The standard finish of the sockets is blue primer coating and hot dipped galvanized (CSS 296 until CSS 201 only galvanized)
- All sockets are provided with an EN 10204-2.1 declaration of conformity and EN 10204-3.1 material certificate.
- Dimensional tolerances are ±5% for the bow opening (K) and bow thickness (T).
- For other dimensional tolerances please contact Ropeblock.
- Surface finish e.g. hot dip galvanizing or paint may add to the overall thickness and fork distance.

SEE OUR WARNING & SAFETY INFORMATION ON PAGES 136 - 149



SHORT BOW SOCKETS

**QUENCHED AND
TEMPERED CAST STEEL**

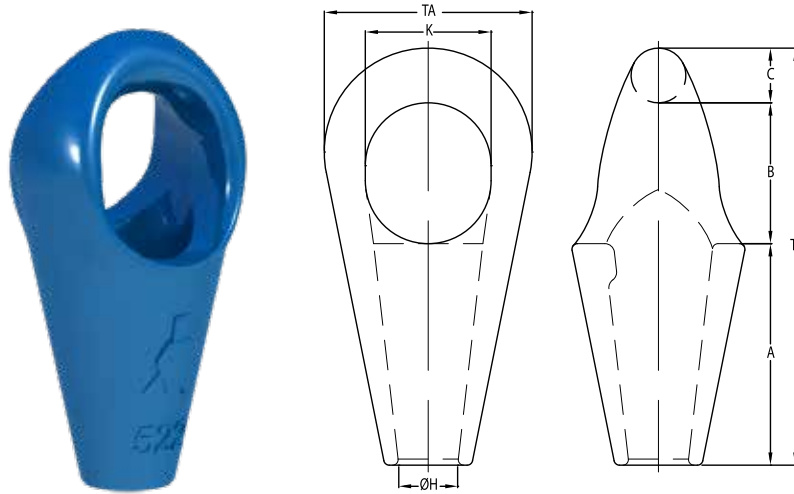

Model No.	MBL (UStons)	for wire ø		Dimensions (inch)							Weight (lbs)
		(mm)	(inch)	A	B	C	øH	K	TA	TL	
SBS 512	154	31-36	1¼ - 1⅜	5.55	3.27	1.50	1.52	2.95	5.20	10.31	15
SBS 517	176	37-42	1½ - 1⅝	6.38	4.06	1.57	1.74	3.62	5.98	12.01	22
SBS 519	220	43-48	1¾ - 1⅞	7.40	4.72	1.89	2.01	4.41	7.01	14.02	34
SBS 522	276	49-54	2 - 2⅛	8.03	5.20	2.13	2.32	4.72	7.87	15.35	46
SBS 524	353	55-60	2¼ - 2⅜	9.06	5.83	2.44	2.52	5.31	8.66	17.32	62
SBS 526	441	61-68	2½ - 2⅝	10.43	6.50	2.68	2.95	5.91	9.84	19.61	96
SBS 527	551	69-75	2¾ - 2⅞	11.30	7.01	2.95	3.11	6.46	10.79	21.26	118
SBS 528	661	76-80	3 - 3⅛	12.36	7.68	2.99	3.50	6.89	11.61	23.03	155
SBS 529	772	81-86	3¼ - 3⅝	12.87	8.50	3.23	3.63	7.64	12.60	24.61	179
SBS 530	882	87-93	3½ - 3⅞	14.09	8.66	3.62	3.90	7.95	13.78	26.38	246
SBS 531	992	94-102	3¾ - 4	14.37	9.25	3.94	4.24	8.46	14.76	27.56	287
SBS 533	1102	108-115	4¼ - 4½	16.54	10.63	4.33	4.72	9.45	16.14	31.50	401

MBL = Minimum Breaking Load

- The standard finish of the sockets is blue primer coating and hot dipped galvanized
- All sockets are provided with an EN 10204-2.1 declaration of conformity and EN 10204-3.1 material certificate.
- Dimensional tolerances are ±5% for the bow opening (K) and bow thickness (C).
- For other dimensional tolerances please contact Ropeblock.
- Surface finish e.g. hot dip galvanizing or paint may add to the overall thickness and fork distance.



**SEE OUR WARNING
& SAFETY INFORMATION
ON PAGES 136 - 149**

FAST CONNECTOR SOCKETS WITH PIN

QUENCHED AND
TEMPERED CAST STEEL

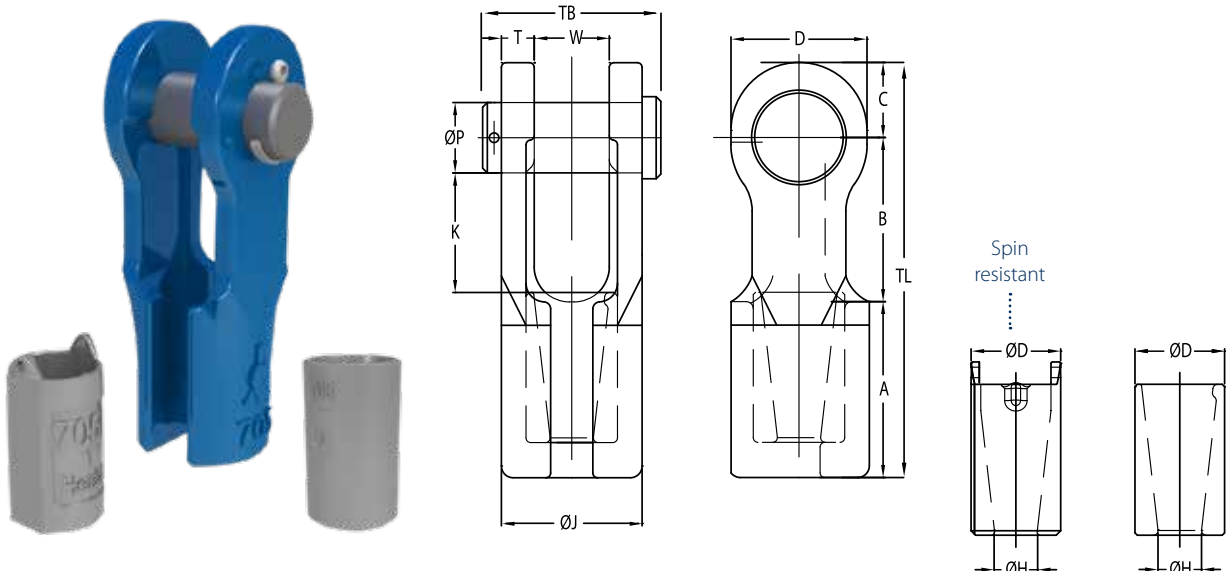

Model No.	Reeving aid	MBL (USTons)	for wire ø		Dimensions (inch)													Weight (lbs)
			(mm)	(inch)	A	B	C	øH	øP	T	W	D	øD	øJ	K	TB	TL	
FCS 701 P	-	22	11-13	7/16 - 1/2	2.44	2.40	1.06	0.59	0.98	0.47	0.98	1.97	1.30	1.93	1.81	2.64	5.91	4
FCS 702 P	-	28	13-16	1/2 - 5/8	2.83	3.07	1.26	0.71	1.18	0.55	1.26	2.28	1.50	2.36	2.32	3.35	7.17	6
FCS 703 P	-	44	16-19	5/8 - 3/4	3.35	3.66	1.57	0.83	1.38	0.63	1.50	2.76	1.77	2.76	2.72	3.74	8.58	10
FCS 704 P	-	61	20-22	7/8	4.02	4.17	1.77	0.94	1.61	0.75	1.73	3.15	1.97	3.23	3.19	4.33	9.96	14
FCS 705 P	-	83	23-26	1	4.53	4.84	2.36	1.10	2.01	0.87	2.01	4.09	2.36	3.74	3.54	5.04	11.73	24
FCS 706 P	-	99	27-29	1 1/8	5.51	5.98	2.56	1.26	2.24	0.98	2.24	4.49	2.76	4.21	4.57	5.59	14.06	35
FCS 705 P.SR	T 705	83	23-26	1	4.53	4.84	2.36	1.10	2.01	0.87	2.01	4.09	2.36	3.74	3.54	5.04	11.73	24
FCS 706 P.SR	T 706	99	27-29	1 1/8	5.51	5.98	2.56	1.26	2.24	0.98	2.24	4.49	2.76	4.21	4.57	5.59	14.06	35
FCS 707 P.SR	T 706	138	30-32	1 1/4	5.91	6.26	2.87	1.42	2.48	1.10	2.48	4.96	3.15	4.69	4.72	6.10	15.04	40
FCS 708 P.SR	T 706	138	33-36	1 3/8	6.30	6.73	2.87	1.54	2.52	1.10	2.72	4.96	3.35	4.92	5.12	6.30	15.91	51
FCS 709 P.SR	T 709	165	37-39	1 1/2	6.93	7.36	3.15	1.65	2.76	1.18	2.99	5.59	3.54	5.35	5.59	6.97	17.44	64
FCS 710 P.SR	T 709	187	40-42	1 5/8	7.40	7.80	3.46	1.77	2.99	1.30	2.99	6.14	3.74	5.59	5.91	7.36	18.66	79
FCS 711 P.SR	T 711	248	43-48	1 3/4 - 1 7/8	8.27	9.13	3.94	2.05	3.50	1.54	3.50	6.93	4.33	6.57	6.89	8.46	21.34	128

MBL = Minimum Breaking Load

- The standard finish of the sockets is blue primer coating and hot dipped galvanized.
- All sockets are provided with an EN 10204-2.1 declaration of conformity and EN 10204-3.1 material certificate.
- Dimensional tolerances are ±5% for the jaw opening (W) and pin diameter (øP).
- For other dimensional tolerances please contact Ropeblock.
- Surface finish e.g. hot dip galvanizing or paint may add to the overall thickness and fork distance.

 SEE OUR WARNING & SAFETY INFORMATION ON PAGES 136 - 149



Available with
Reeving tool
(optional)



FAST CONNECTOR SOCKETS WITH BOLT AND NUT

**QUENCHED AND
TEMPERED CAST STEEL**

SOCKETS

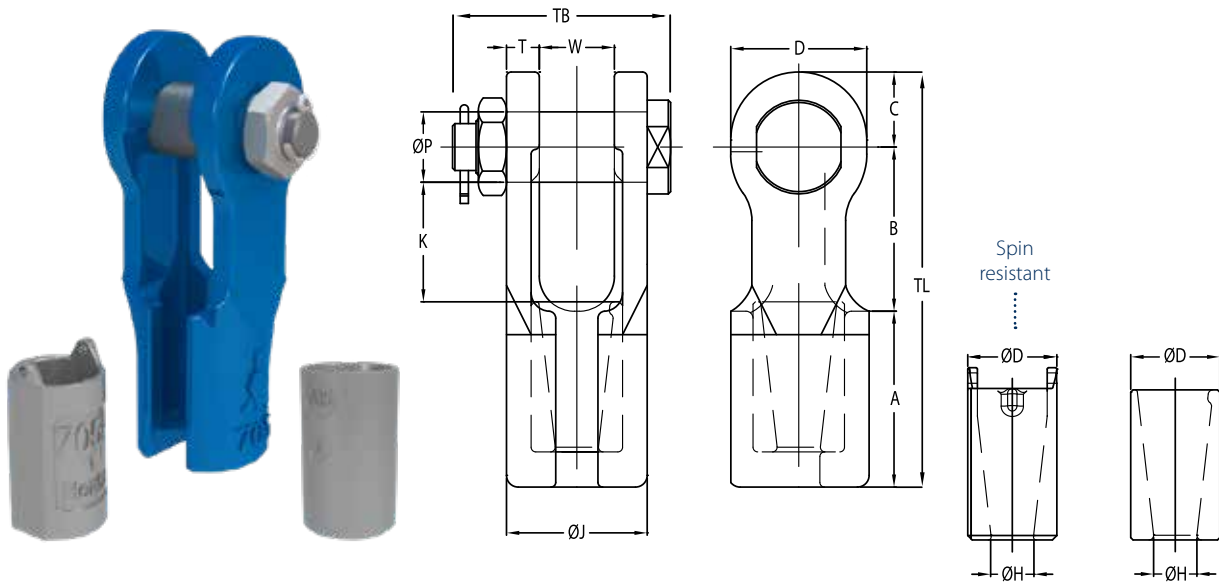

Model No.	Reeving aid	MBL (UStons)	for wire ø		Dimensions (inch)													Weight (lbs)
			(mm)	(inch)	A	B	C	øH	øP	T	W	D	øD	øJ	K	TB	TL	
FCS 701 B	-	22	11-13	7/16 - 1/2	2.44	2.40	1.06	0.59	0.98	0.47	0.98	1.97	1.30	1.93	1.81	3.15	5.91	4
FCS 702 B	-	28	13-16	1/2 - 5/8	2.83	3.07	1.26	0.71	1.18	0.55	1.26	2.28	1.50	2.36	2.32	3.78	7.17	6
FCS 703 B	-	44	16-19	5/8 - 3/4	3.35	3.66	1.57	0.83	1.38	0.63	1.50	2.76	1.77	2.76	2.72	4.21	8.58	10
FCS 704 B	-	61	20-22	7/8	4.02	4.17	1.77	0.94	1.61	0.75	1.73	3.15	1.97	3.23	3.19	4.84	9.96	14
FCS 705 B	-	83	23-26	1	4.53	4.84	2.36	1.10	2.01	0.87	2.01	4.09	2.36	3.74	3.54	5.43	11.73	24
FCS 706 B	-	99	27-29	1 1/8	5.51	5.98	2.56	1.26	2.24	0.98	2.24	4.49	2.76	4.21	4.57	6.30	14.06	35
FCS 705 B.SR	T 705	83	23-26	1	4.53	4.84	2.36	1.10	2.01	0.87	2.01	4.09	2.36	3.74	3.54	5.43	11.73	24
FCS 706 B.SR	T 706	99	27-29	1 1/8	5.51	5.98	2.56	1.26	2.24	0.98	2.24	4.49	2.76	4.21	4.57	6.30	14.06	35
FCS 707 B.SR	T 706	138	30-32	1 1/4	5.91	6.26	2.87	1.42	2.48	1.10	2.48	4.96	3.15	4.69	4.72	6.50	15.04	40
FCS 708 B.SR	T 706	138	33-36	1 3/8	6.30	6.73	2.87	1.54	2.52	1.10	2.72	4.96	3.35	4.92	5.12	7.28	15.91	51
FCS 709 B.SR	T 709	165	37-39	1 1/2	6.93	7.36	3.15	1.65	2.76	1.18	2.99	5.59	3.54	5.35	5.59	7.91	17.44	64
FCS 710 B.SR	T 709	187	40-42	1 5/8	7.40	7.80	3.46	1.77	2.99	1.30	2.99	6.14	3.74	5.59	5.91	8.23	18.66	79
FCS 711 B.SR	T 711	248	43-48	1 3/4 - 1 7/8	8.27	9.13	3.94	2.05	3.50	1.54	3.50	6.93	4.33	6.57	6.89	9.33	21.34	128

MBL = Minimum Breaking Load

- The standard finish of the sockets is blue primer coating and hot dipped galvanized.
- All sockets are provided with an EN 10204-2.1 declaration of conformity and EN 10204-3.1 material certificate.
- Dimensional tolerances are ±5% for the jaw opening (W) and pin diameter (øP).
- For other dimensional tolerances please contact Ropeblock.
- Surface finish e.g. hot dip galvanizing or paint may add to the overall thickness and fork distance.

SEE OUR WARNING & SAFETY INFORMATION ON PAGES 136 - 149



Available with
Reeving tool
(optional)

SEE OUR WARNING AND SAFETY INFORMATION ON PAGE 136



SUPER REEVE CONNECTOR SOCKETS WITH PIN

QUENCHED AND TEMPERED CAST STEEL

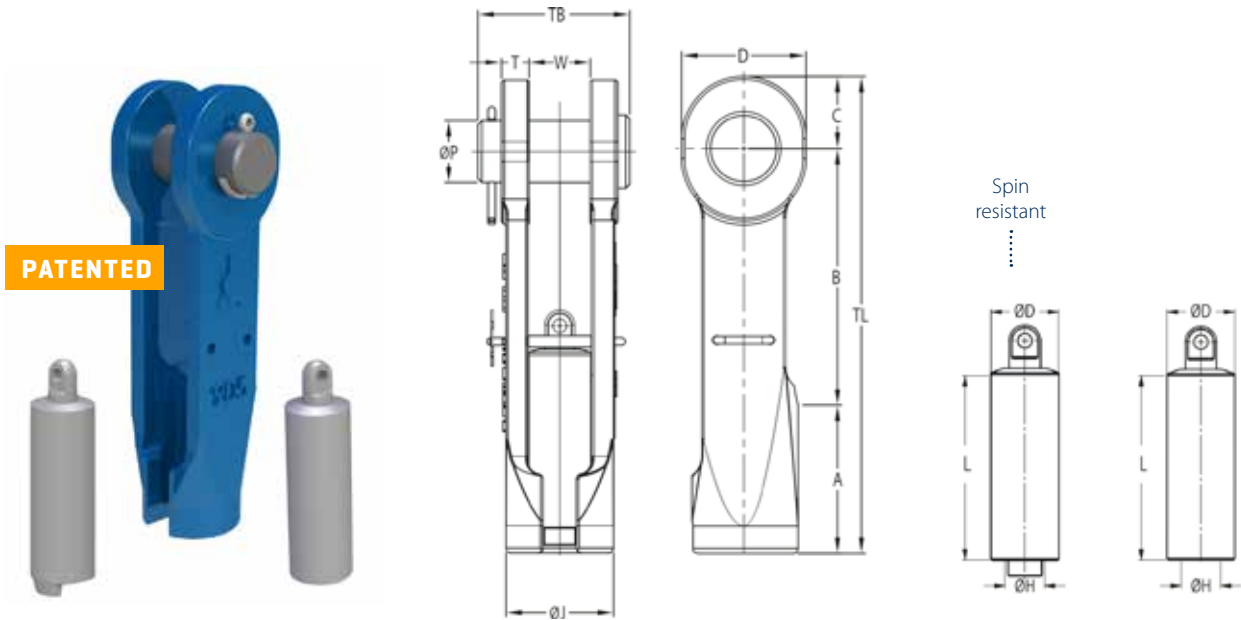

Model No.	MBL (UStons)	for wire ø		Dimensions (inch)													Weight (lbs)	
		(mm)	(inch)	A	B	C	øH	øP	T	W	D	øD	øJ	L	TB	TL		
SCS 901 P	22	11-13	7/16 - 1/2	-	-	-	-	-	-	-	-	-	-	-	-	-	-	-
SCS 902 P	28	13-16	1/2 - 5/8	3.35	5.24	1.26	0.75	1.18	0.55	1.26	2.28	1.26	2.20	3.86	3.35	9.84	7	
SCS 903 P	44	16-19	5/8 - 3/4	3.54	6.30	1.57	0.87	1.38	0.63	1.50	2.76	1.57	2.56	4.49	3.74	11.42	11	
SCS 904 P	61	20-22	7/8	4.21	7.24	1.77	1.00	1.61	0.75	1.73	3.15	1.73	3.03	5.12	4.33	13.23	17	
SCS 905 P	83	23-26	1	4.53	8.31	2.36	1.20	1.97	0.87	2.01	4.09	2.05	3.46	5.59	5.04	15.20	26	
SCS 906 P	99	27-29	1 1/8	5.51	8.46	2.56	1.34	2.24	0.98	2.24	4.49	2.28	3.78	6.26	5.59	16.54	35	
SCS 907 P	138	30-32	1 1/4	5.91	10.24	2.87	1.43	2.48	1.10	2.48	4.96	2.52	4.33	6.97	6.10	19.02	51	
SCS 908 P	138	33-36	1 3/8	6.69	10.24	2.87	1.56	2.52	1.10	2.72	4.96	2.68	4.49	7.76	6.30	19.80	55	
SCS 902 P.SR	28	13-16	1/2 - 5/8	3.35	5.24	1.26	0.75	1.18	0.55	1.26	2.28	1.26	2.20	3.86	3.35	9.84	7	
SCS 903 P.SR	44	16-19	5/8 - 3/4	3.54	6.30	1.57	0.87	1.38	0.63	1.50	2.76	1.57	2.56	4.49	3.74	11.42	11	
SCS 904 P.SR	61	20-22	7/8	4.21	7.24	1.77	1.00	1.61	0.75	1.73	3.15	1.73	3.03	5.12	4.33	13.23	17	
SCS 905 P.SR	83	23-26	1	4.53	8.31	2.36	1.20	1.97	0.87	2.01	4.09	2.05	3.46	5.59	5.04	15.20	26	
SCS 906 P.SR	99	27-29	1 1/8	5.51	8.46	2.56	1.34	2.24	0.98	2.24	4.49	2.28	3.78	6.26	5.59	16.54	35	
SCS 907 P.SR	138	30-32	1 1/4	5.91	10.24	2.87	1.43	2.48	1.10	2.48	4.96	2.52	4.33	6.97	6.10	19.02	51	
SCS 908 P.SR	138	33-36	1 3/8	6.69	10.24	2.87	1.56	2.52	1.10	2.72	4.96	2.68	4.49	7.76	6.30	19.80	55	
SCS 909 P.SR	165	37-39	1 1/2	-	-	-	-	-	-	-	-	-	-	-	-	-	-	
SCS 910 P.SR	187	40-42	1 5/8	-	-	-	-	-	-	-	-	-	-	-	-	-	-	
SCS 911 P.SR	248	43-48	1 3/4 - 1 7/8	-	-	-	-	-	-	-	-	-	-	-	-	-	-	
SCS 912 P.SR	309	49-54	2 - 2 1/2	8.86	14.69	4.25	2.36	3.74	1.77	3.98	7.64	4.13	7.28	11.02	9.61	27.80	205	

MBL = Minimum Breaking Load

- The standard finish of the sockets is blue primer coating and hot dipped galvanized.
- All sockets are provided with an EN 10204-2.1 declaration of conformity and EN 10204-3.1 material certificate.
- Dimensional tolerances are ±5% for the jaw opening (W) and pin diameter (øP).
- For other dimensional tolerances please contact Ropeblock.
- Surface finish e.g. hot dip galvanizing or paint may add to the overall thickness and fork distance.

SEE OUR WARNING & SAFETY INFORMATION ON PAGES 136 - 149



SUPER REEVE CONNECTOR SOCKET WITH BOLT AND NUT

**QUENCHED AND
TEMPERED CAST STEEL**

SOCKETS

PATENTED

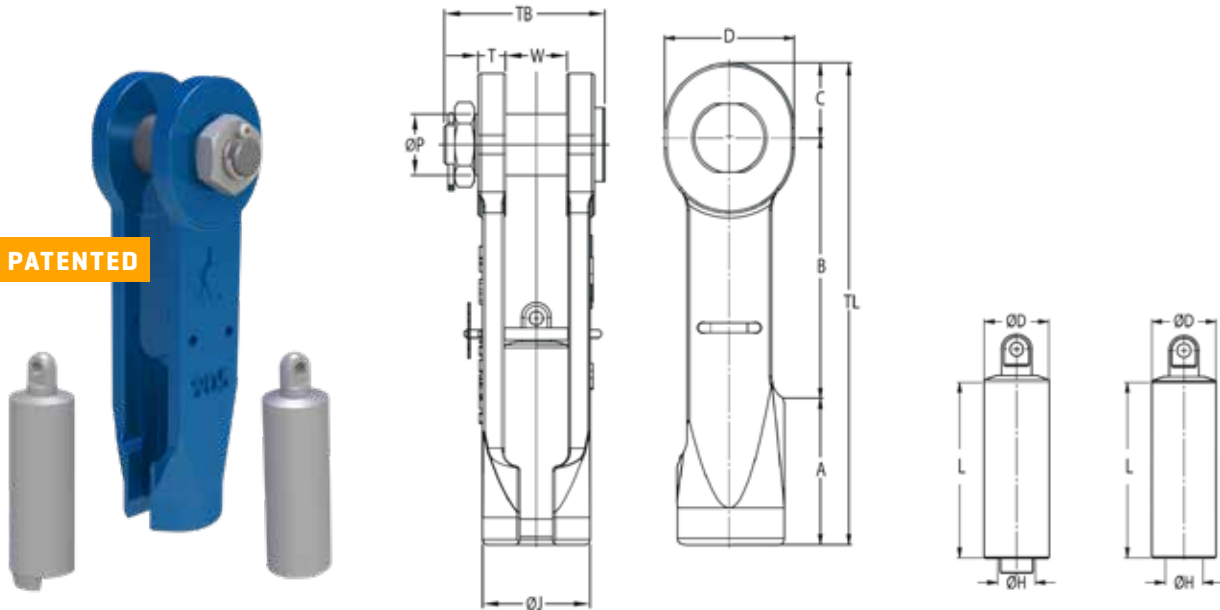

Model No.	MBL (UStons)	for wire ø		Dimensions (inch)													Weight (lbs)
		(mm)	(inch)	A	B	C	øH	øP	T	W	D	øD	øJ	L	TB	TL	
SCS 901 B	22	11-13	7/16 - 1/2	-	-	-	-	-	-	-	-	-	-	-	-	-	-
SCS 902 B	28	13-16	1/2 - 5/8	3.35	5.24	1.26	0.75	1.18	0.55	1.26	2.28	1.26	2.20	3.86	3.78	9.84	7
SCS 903 B	44	16-19	5/8 - 3/4	3.54	6.30	1.57	0.87	1.38	0.63	1.50	2.76	1.57	2.56	4.49	4.21	11.42	11
SCS 904 B	61	20-22	7/8	4.21	7.24	1.77	1.00	1.61	0.75	1.73	3.15	1.73	3.03	5.12	4.84	13.23	17
SCS 905 B	83	23-26	1	4.53	8.31	2.36	1.20	1.97	0.87	2.01	4.09	2.05	3.46	5.59	5.43	15.20	26
SCS 906 B	99	27-29	1 1/8	5.51	8.46	2.56	1.34	2.24	0.98	2.24	4.49	2.28	3.78	6.26	6.30	16.54	35
SCS 907 B	138	30-32	1 1/4	5.91	10.24	2.87	1.43	2.48	1.10	2.48	4.96	2.52	4.33	6.97	6.50	19.02	51
SCS 908 B	138	33-36	1 3/8	6.69	10.24	2.87	1.56	2.52	1.10	2.72	4.96	2.68	4.49	7.76	7.28	19.80	55
SCS 902 B.SR	28	13-16	1/2 - 5/8	3.35	5.24	1.26	0.75	1.18	0.55	1.26	2.28	1.26	2.20	3.86	3.78	9.84	7
SCS 903 B.SR	44	16-19	5/8 - 3/4	3.54	6.30	1.57	0.87	1.38	0.63	1.50	2.76	1.57	2.56	4.49	4.21	11.42	11
SCS 904 B.SR	61	20-22	7/8	4.21	7.24	1.77	1.00	1.61	0.75	1.73	3.15	1.73	3.03	5.12	4.84	13.23	17
SCS 905 B.SR	83	23-26	1	4.53	8.31	2.36	1.20	1.97	0.87	2.01	4.09	2.05	3.46	5.59	5.43	15.20	26
SCS 906 B.SR	99	27-29	1 1/8	5.51	8.46	2.56	1.34	2.24	0.98	2.24	4.49	2.28	3.78	6.26	6.30	16.54	35
SCS 907 B.SR	138	30-32	1 1/4	5.91	10.24	2.87	1.43	2.48	1.10	2.48	4.96	2.52	4.33	6.97	6.50	19.02	51
SCS 908 B.SR	138	33-36	1 3/8	6.69	10.24	2.87	1.56	2.52	1.10	2.72	4.96	2.68	4.49	7.76	7.28	19.80	55
SCS 909 B.SR	165	37-39	1 1/2	-	-	-	-	-	-	-	-	-	-	-	-	-	-
SCS 910 B.SR	187	40-42	1 5/8	-	-	-	-	-	-	-	-	-	-	-	-	-	-
SCS 911 B.SR	248	43-48	1 3/4 - 1 7/8	-	-	-	-	-	-	-	-	-	-	-	-	-	-
SCS 912 B.SR	309	49-54	2 - 2 1/8	8.86	14.69	4.25	2.36	3.74	1.77	3.98	7.64	4.13	7.28	11.02	10.35	27.80	205

MBL = Minimum Breaking Load

- The standard finish of the sockets is blue primer coating and hot dipped galvanized.
- All sockets are provided with an EN 10204-2.1 declaration of conformity and EN 10204-3.1 material certificate.
- Dimensional tolerances are ±5% for the jaw opening (W) and pin diameter (øP).
- For other dimensional tolerances please contact Ropeblock.
- Surface finish e.g. hot dip galvanizing or paint may add to the overall thickness and fork distance.



SEE OUR WARNING AND SAFETY INFORMATION ON PAGE 136



SUPER REEVE CONNECTOR SWIVEL SOCKETS WITH PIN

QUENCHED AND TEMPERED CAST STEEL

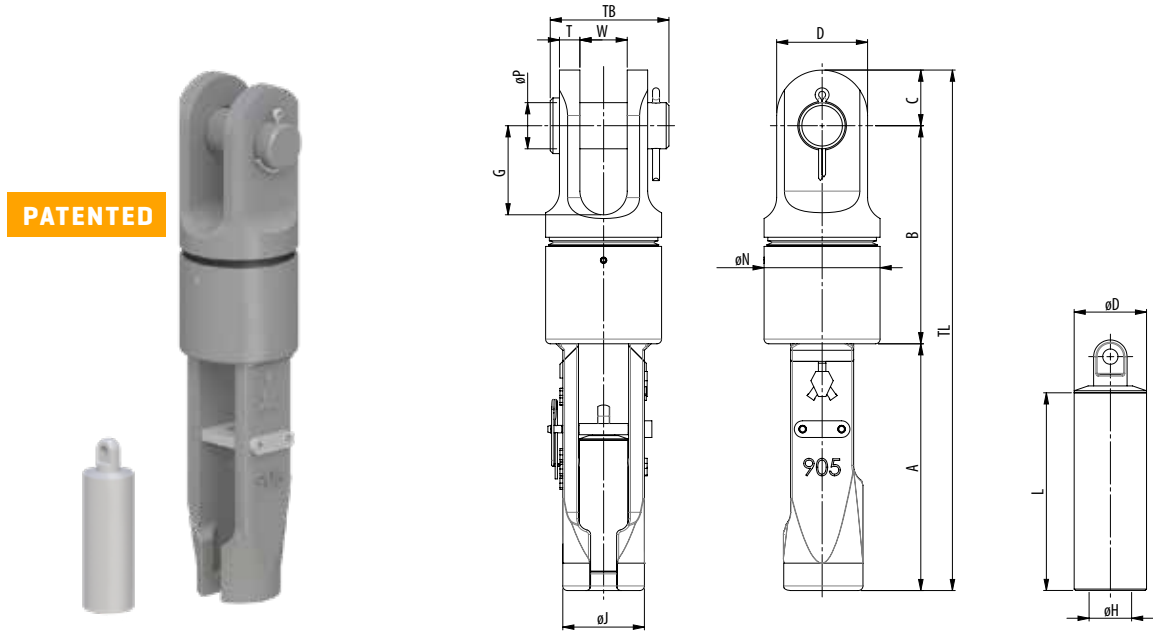

Model No.	MBL (UStons)	for wire ø		Dimensions (inch)															Weight (lbs)
		(mm)	(inch)	A	B	C	øH	øP	T	W	G	D	øD	øJ	øN	L	TB	TL	
SCS-SW 902 P	28	13-16	½ - ⅝	7.17	6.18	1.26	0.75	1.18	0.55	1.26	2.36	2.28	1.26	2.20	2.99	3.86	3.35	14.61	15
SCS-SW 903 P	44	16-19	⅝ - ¾	8.19	7.32	1.57	0.87	1.38	0.63	1.50	2.76	2.76	1.57	2.56	3.66	4.49	3.74	17.09	24
SCS-SW 904 P	61	20-22	⅞	9.37	8.19	1.77	1.00	1.61	0.75	1.73	3.15	3.15	1.73	3.03	4.13	5.12	4.33	19.33	37
SCS-SW 905 P	83	23-26	1	10.47	9.25	2.36	1.20	1.97	0.87	2.01	3.78	3.86	2.05	3.46	4.92	5.59	5.04	22.09	57
SCS-SW 906 P	99	27-29	1⅛	11.42	10.31	2.56	1.34	2.24	0.98	2.24	4.21	4.25	2.28	3.78	5.31	6.26	5.59	24.29	75
SCS-SW 907 P	138	30-32	1¼	12.87	11.50	2.87	1.43	2.48	1.10	2.48	4.65	4.72	2.52	4.33	5.91	6.97	6.10	27.24	108

MBL = Minimum Breaking Load

- The standard finish of the sockets is blue primer coating and hot dipped galvanized.
- All sockets are provided with an EN 10204-2.1 declaration of conformity and EN 10204-3.1 material certificate.
- Dimensional tolerances are ±5% for the jaw opening (W) and pin diameter (øP).
- For other dimensional tolerances please contact Ropeblock.
- Surface finish e.g. hot dip galvanizing or paint may add to the overall thickness and fork distance.

SEE OUR WARNING & SAFETY INFORMATION ON PAGES 136 - 149



SUPER REEVE CONNECTOR SWIVEL SOCKETS WITH BOLT AND NUT

**QUENCHED AND
TEMPERED CAST STEEL**

SOCKETS

PATENTED

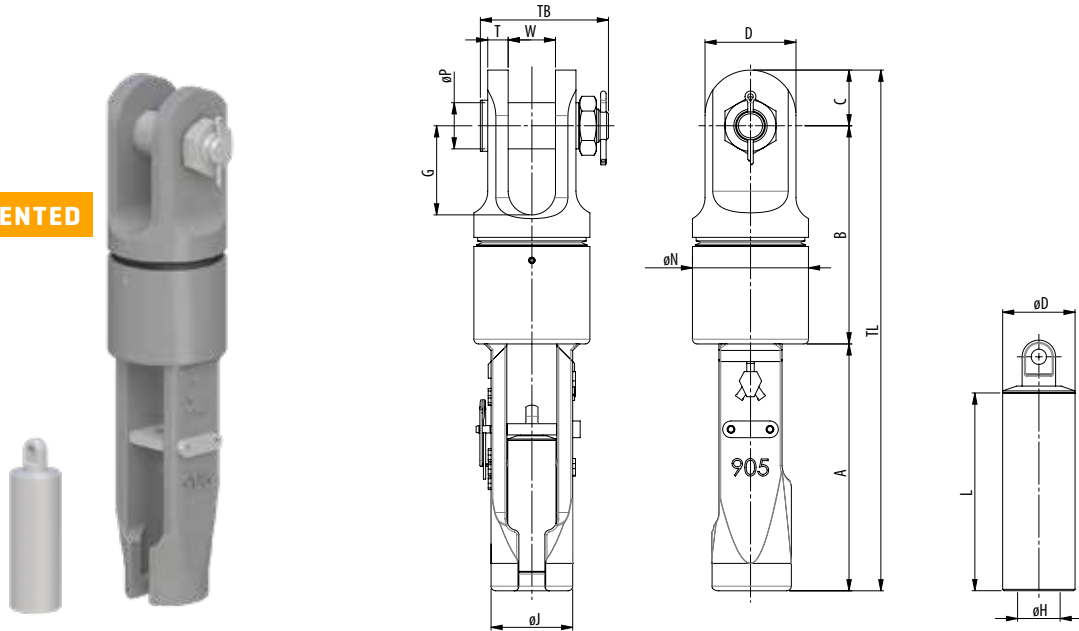

Model No.	MBL (UStons)	for wire ø		Dimensions (inch)															Weight (lbs)
		(mm)	(inch)	A	B	C	øH	øP	T	W	G	D	øD	øJ	øN	L	TB	TL	
SCS-SW 902 B	28	13-16	½ - ⅝	7.17	6.18	1.26	0.75	1.18	0.55	1.26	2.36	2.28	1.26	2.20	2.99	3.86	3.78	14.61	15
SCS-SW 903 B	44	16-19	⅝ - ¾	8.19	7.32	1.57	0.87	1.38	0.63	1.50	2.76	2.76	1.57	2.56	3.66	4.49	4.21	17.09	24
SCS-SW 904 B	61	20-22	⅞	9.37	8.19	1.77	1.00	1.61	0.75	1.73	3.15	3.15	1.73	3.03	4.13	5.12	4.84	19.33	37
SCS-SW 905 B	83	23-26	1	10.47	9.25	2.36	1.20	1.97	0.87	2.01	3.78	3.86	2.05	3.46	4.92	5.59	5.43	22.09	57
SCS-SW 906 B	99	27-29	1⅛	11.42	10.31	2.56	1.34	2.24	0.98	2.24	4.21	4.25	2.28	3.78	5.31	6.26	6.30	24.29	75
SCS-SW 907 B	138	30-32	1¼	12.87	11.50	2.87	1.43	2.48	1.10	2.48	4.65	4.72	2.52	4.33	5.91	6.97	6.50	27.24	108

MBL = Minimum Breaking Load

- The standard finish of the sockets is blue primer coating and hot dipped galvanized.
- All sockets are provided with an EN 10204-2.1 declaration of conformity and EN 10204-3.1 material certificate.
- Dimensional tolerances are ±5% for the jaw opening (W) and pin diameter (øP).
- For other dimensional tolerances please contact Ropeblock.
- Surface finish e.g. hot dip galvanizing or paint may add to the overall thickness and fork distance.



**SEE OUR WARNING
& SAFETY INFORMATION
ON PAGES 136 - 148**



OPEN WEDGE SOCKETS WITH PIN

QUENCHED AND TEMPERED CAST STEEL

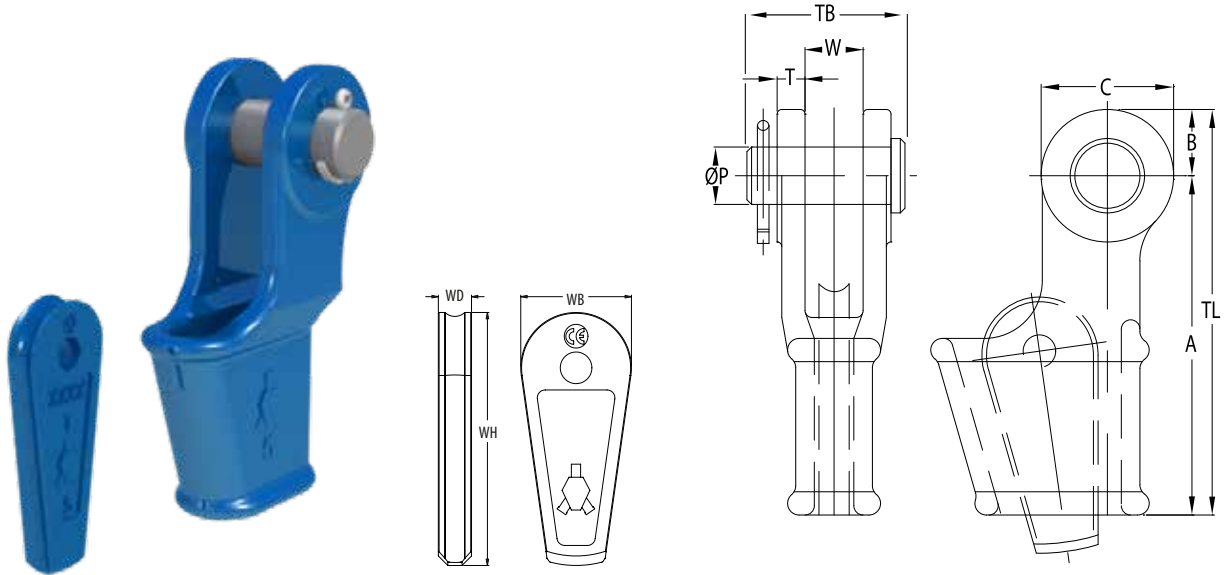

Model No.	MBL (UStons)	for wire ø		Dimensions (inch)											Weight (lbs)
		(mm)	(inch)	A	B	C	øP	T	TL	TB	W	WH	WB	WD	
OWS 0.25 P	9	7-8	5/16	4.33	0.71	1.42	0.63	0.35	5.04	2.01	0.71	2.74	1.38	0.33	2
OWS 0.5 P	13	9-10	3/8	5.71	0.91	1.81	0.81	0.43	6.61	2.48	0.81	2.91	1.42	0.47	4
OWS 1 P	22	11-13	1/2	5.75	1.12	2.24	0.98	0.47	6.87	2.64	0.98	4.53	1.89	0.55	5
OWS 2 P	28	14-16	5/8	6.93	1.38	2.76	1.18	0.59	8.31	3.35	1.22	5.30	2.24	0.71	9
OWS 3 P	44	18-19	3/4	8.27	1.57	3.15	1.38	0.63	9.84	3.74	1.50	6.30	2.76	0.83	15
OWS 4 P	61	20-22	7/8	9.35	1.87	3.74	1.61	0.71	11.22	4.33	1.73	7.34	3.03	0.94	22
OWS 5 P	83	23-26	1	10.83	2.17	4.33	2.01	0.87	12.99	5.04	2.01	8.33	3.27	1.08	33
OWS 6 P	99	27-29	1 1/8	12.20	2.56	5.12	2.24	0.98	14.76	5.59	2.24	9.11	3.58	1.18	46
OWS 7 P	121	30-32	1 1/4	13.78	2.87	5.75	2.48	1.10	16.65	6.10	2.48	10.47	4.25	1.30	68
OWS 8 P	138	34-36	1 3/8	15.75	2.91	5.83	2.52	1.10	18.66	6.30	2.76	11.73	4.57	1.38	82
OWS 9 P	165	37-39	1 1/2	17.72	3.15	5.59	2.76	1.18	20.87	6.97	3.03	13.31	5.12	1.50	112
OWS 10 P	187	40-42	1 5/8	19.69	3.43	6.30	2.99	1.30	23.11	7.36	2.99	14.67	5.51	1.61	141
OWS 11 P	248	43-48	1 3/4 - 1 7/8	21.65	3.94	7.32	3.50	1.54	25.59	8.46	3.50	16.06	5.75	1.89	212
OWS 12 P	309	49-52	2	25.20	4.13	8.07	3.74	1.81	29.33	9.61	3.98	17.72	6.30	2.09	287
OWS 13 P	397	54-58	2 1/4	25.98	4.92	9.84	4.25	2.13	30.91	10.83	4.49	18.50	6.61	2.28	397
OWS 14 P	468	60-68	2 1/2	32.87	5.31	10.63	4.76	2.36	38.19	11.81	5.00	19.69	6.93	2.56	606
OWS 15 P	507	72-76	3	39.37	5.91	11.81	5.24	2.99	45.28	13.98	5.75	21.65	9.61	2.76	970
OWS 16 P	689	81-86	3 1/4 - 3 5/8	43.31	5.91	11.81	5.51	3.11	49.21	14.76	6.26	26.38	10.24	3.15	1124

MBL = Minimum Breaking Load

- The standard finish of the sockets is blue primer coating and hot dipped galvanized (OWS 0,25 and OWS 0,5 only galvanized)
- All sockets are provided with an EN 10204-2.1 declaration of conformity and EN 10204-3.1 material certificate.
- Dimensional tolerances are ±5% for the jaw opening (W) and pin diameter (øP).
- For other dimensional tolerances please contact Ropeblock.
- Surface finish e.g. hot dip galvanizing or paint may add to the overall thickness and fork distance.

SEE OUR WARNING & SAFETY INFORMATION ON PAGES 136 - 149



OPEN WEDGE SOCKETS WITH BOLT AND NUT

QUENCHED AND TEMPERED CAST STEEL

SOCKETS

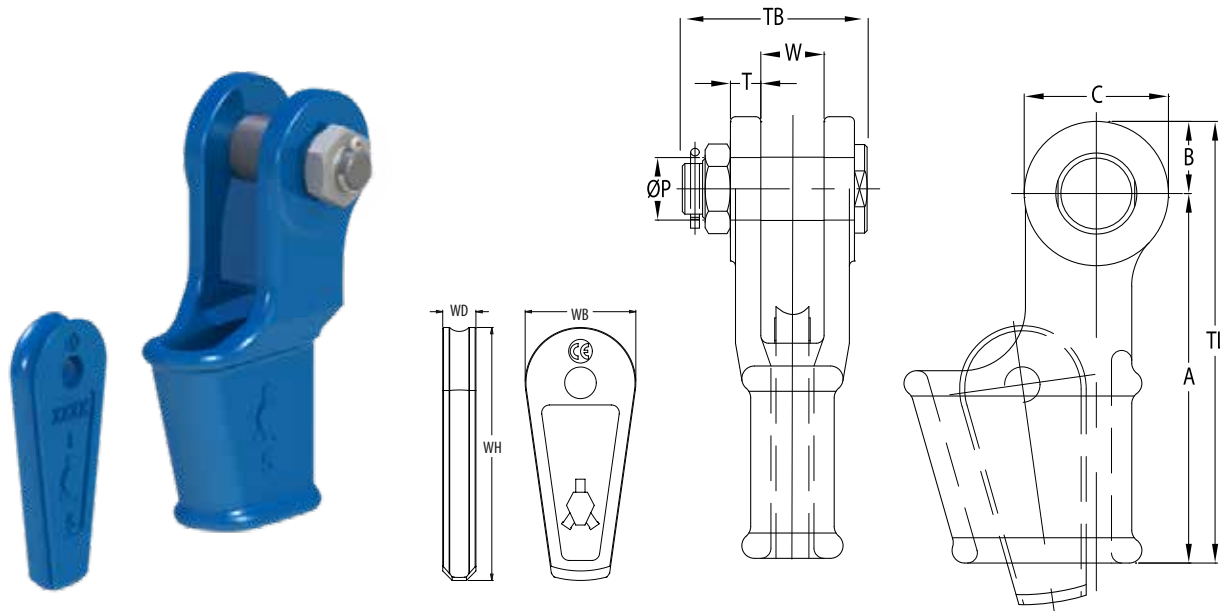

Model No.	MBL (UStons)	for wire ø		Dimensions (inch)										Weight (lbs)	
		(mm)	(inch)	A	B	C	øP	T	TL	TB	W	WH	WB		WD
OWS 0.25 B	9	7-8	5/16	4.33	0.71	1.42	0.63	0.35	5.04	2.44	0.71	2.74	1.38	0.33	2
OWS 0.5 B	13	9-10	3/8	5.71	0.91	1.81	0.81	0.43	6.61	2.95	0.81	2.91	1.42	0.47	4
OWS 1 B	22	11-13	1/2	5.75	1.12	2.24	0.98	0.47	6.87	3.15	0.98	4.53	1.89	0.55	5
OWS 2 B	28	14-16	5/8	6.93	1.38	2.76	1.18	0.59	8.31	3.78	1.22	5.30	2.24	0.71	9
OWS 3 B	44	18-19	3/4	8.27	1.57	3.15	1.38	0.63	9.84	4.21	1.50	6.30	2.76	0.83	15
OWS 4 B	61	20-22	7/8	9.35	1.87	3.74	1.61	0.71	11.22	4.84	1.73	7.34	3.03	0.94	22
OWS 5 B	83	23-26	1	10.83	2.17	4.33	2.01	0.87	12.99	5.43	2.01	8.33	3.27	1.08	33
OWS 6 B	99	27-29	1 1/8	12.20	2.56	5.12	2.24	0.98	14.76	6.30	2.24	9.11	3.58	1.18	46
OWS 7 B	121	30-32	1 1/4	13.78	2.87	5.75	2.48	1.10	16.65	6.50	2.48	10.47	4.25	1.30	68
OWS 8 B	138	34-36	1 3/8	15.75	2.91	5.83	2.52	1.10	18.66	7.28	2.76	11.73	4.57	1.38	82
OWS 9 B	165	37-39	1 1/2	17.72	3.15	5.59	2.76	1.18	20.87	7.91	3.03	13.31	5.12	1.50	112
OWS 10 B	187	40-42	1 5/8	19.69	3.43	6.30	2.99	1.30	23.11	8.23	2.99	14.67	5.51	1.61	141
OWS 11 B	248	43-48	1 3/4 - 1	21.65	3.94	7.32	3.50	1.54	25.59	9.33	3.50	16.06	5.75	1.89	212
OWS 12 B	309	49-52	2	25.20	4.13	8.07	3.74	1.81	29.33	10.35	3.98	17.72	6.30	2.09	287
OWS 13 B	397	54-58	2 1/4	25.98	4.92	9.84	4.25	2.13	30.91	11.73	4.49	18.50	6.61	2.28	397
OWS 14 B	468	60-68	2 1/2	32.87	5.31	10.63	4.76	2.36	38.19	12.99	5.00	19.69	6.93	2.56	606
OWS 15 B	507	72-76	3	39.37	5.91	11.81	5.24	2.99	45.28	14.96	5.75	21.65	9.61	2.76	970
OWS 16 B	689	81-86	3 1/4 - 3	43.31	5.91	11.81	5.51	3.11	49.21	15.63	6.26	26.38	10.24	3.15	1124

MBL = Minimum Breaking Load

- The standard finish of the sockets is blue primer coating and hot dipped galvanized (OWS 0,25 and OWS 0,5 only galvanized)
- All sockets are provided with an EN 10204-2.1 declaration of conformity and EN 10204-3.1 material certificate.
- Dimensional tolerances are ±5% for the jaw opening (W) and pin diameter (øP).
- For other dimensional tolerances please contact Ropeblock.
- Surface finish e.g. hot dip galvanizing or paint may add to the overall thickness and fork distance.



SEE OUR WARNING AND SAFETY INFORMATION ON PAGE 136



TAILGRIP OPEN WEDGE SOCKETS WITH PIN

QUENCHED AND TEMPERED CAST STEEL

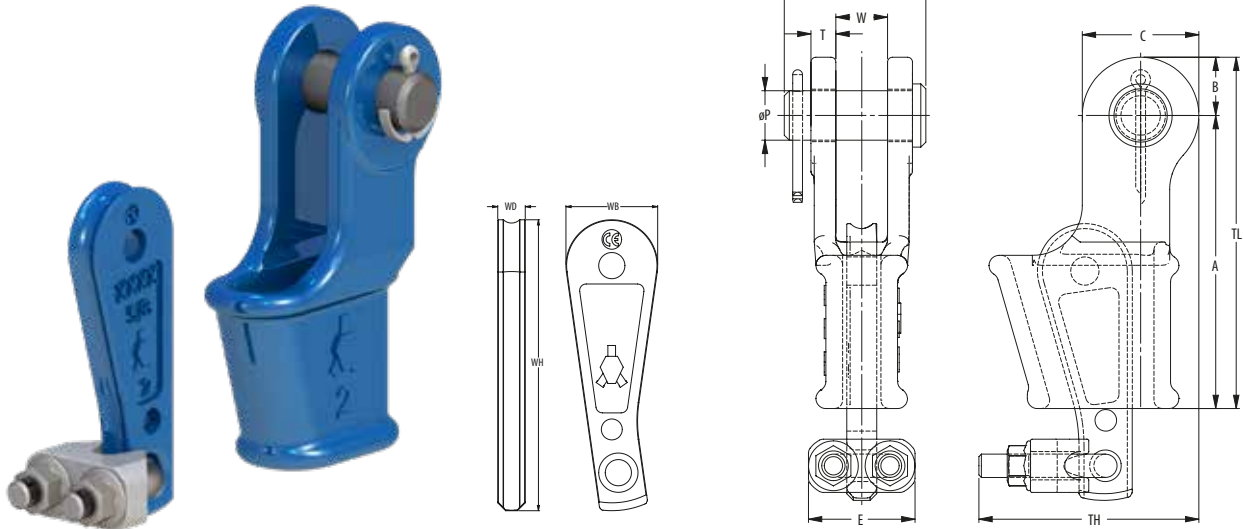

Model No.	MBL (UStons)	for wire ø		Dimensions (inch)													Weight (lbs)
		(mm)	(inch)	A	B	C	E	øP	T	TH	TL	TB	W	WH	WB	WD	
OWS-TG 0.5 P	13	9-10	3/8	5.71	0.91	1.81	1.57	0.81	0.43	2.99	6.61	2.48	0.81	5.12	1.42	0.47	4
OWS-TG 1 P	22	11-13	1/2	5.75	1.12	2.24	2.17	0.98	0.47	3.94	6.87	2.64	0.98	6.69	1.89	0.55	5
OWS-TG 2 P	28	14-16	5/8	6.93	1.38	2.76	2.52	1.18	0.59	4.92	8.31	3.35	1.22	7.66	2.24	0.71	9
OWS-TG 3 P	44	18-19	3/4	8.27	1.57	3.15	2.68	1.38	0.63	5.59	9.84	3.74	1.50	8.74	2.76	0.83	15
OWS-TG 4 P	61	20-22	7/8	9.35	1.87	3.74	2.91	1.61	0.71	6.46	11.22	4.33	1.73	9.86	3.03	0.94	22
OWS-TG 5 P	83	23-26	1	10.83	2.17	4.33	3.31	2.01	0.87	7.44	12.99	5.04	2.01	10.79	3.27	1.08	33
OWS-TG 6 P	99	27-29	1 1/8	12.20	2.56	5.12	3.74	2.24	0.98	8.54	14.76	5.59	2.24	11.48	3.58	1.18	46
OWS-TG 7 P	121	30-32	1 1/4	13.78	2.87	5.75	4.13	2.48	1.10	9.37	16.65	6.10	2.48	13.74	4.25	1.30	68

MBL = Minimum Breaking Load

- The standard finish of the sockets is blue primer coating and hot dipped galvanized (OWS 0,5 only galvanized)
- All sockets are provided with an EN 10204-2.1 declaration of conformity and EN 10204-3.1 material certificate.
- Dimensional tolerances are ±5% for the jaw opening (W) and pin diameter (øP).
- For other dimensional tolerances please contact Ropeblock.
- Surface finish e.g. hot dip galvanizing or paint may add to the overall thickness and fork distance.



SEE OUR WARNING & SAFETY INFORMATION ON PAGES 136 - 149



TAILGRIP OPEN WEDGE SOCKETS WITH BOLT AND NUT

**QUENCHED AND
TEMPERED CAST STEEL**

SOCKETS

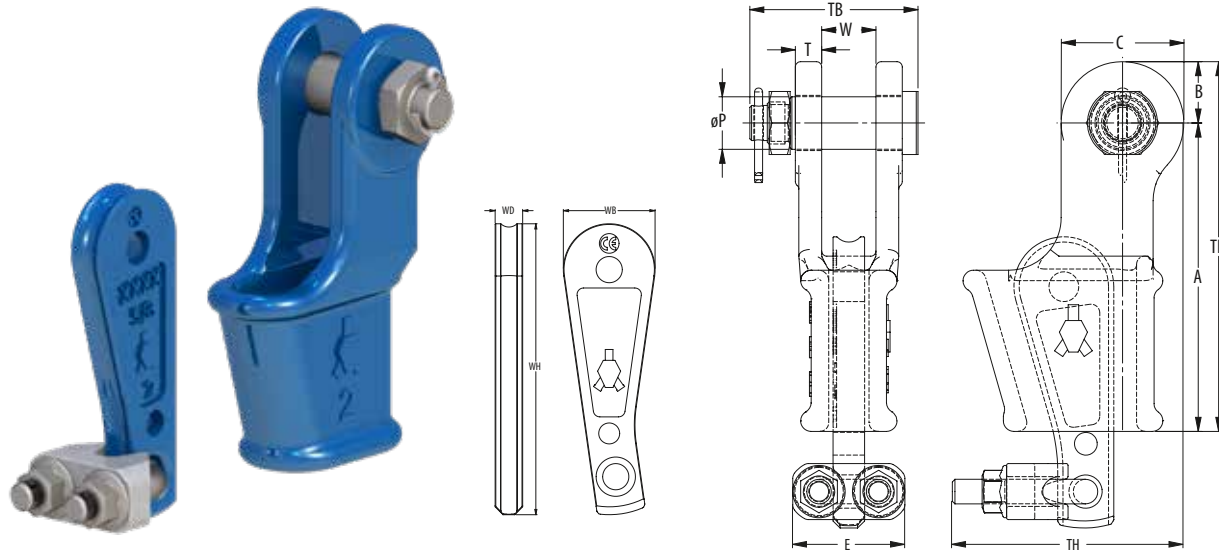

Model No.	MBL (UStons)	for wire ø		Dimensions (inch)													Weight (lbs)
		(mm)	(inch)	A	B	C	E	øP	T	TH	TL	TB	W	WH	WB	WD	
OWS-TG 0.5 B	13	9-10	3/8	5.71	0.91	1.81	1.57	0.81	0.43	2.99	6.61	2.48	0.81	5.12	1.42	0.47	4
OWS-TG 1 B	22	11-13	1/2	5.75	1.12	2.24	2.17	0.98	0.47	3.94	6.87	2.64	0.98	6.69	1.89	0.55	5
OWS-TG 2 B	28	14-16	5/8	6.93	1.38	2.76	2.52	1.18	0.59	4.92	8.31	3.35	1.22	7.66	2.24	0.71	9
OWS-TG 3 B	44	18-19	3/4	8.27	1.57	3.15	2.68	1.38	0.63	5.59	9.84	3.74	1.50	8.74	2.76	0.83	15
OWS-TG 4 B	61	20-22	7/8	9.35	1.87	3.74	2.91	1.61	0.71	6.46	11.22	4.33	1.73	9.86	3.03	0.94	22
OWS-TG 5 B	83	23-26	1	10.83	2.17	4.33	3.31	2.01	0.87	7.44	12.99	5.04	2.01	10.79	3.27	1.08	33
OWS-TG 6 B	99	27-29	1 1/8	12.20	2.56	5.12	3.74	2.24	0.98	8.54	14.76	5.59	2.24	11.48	3.58	1.18	46
OWS-TG 7 B	121	30-32	1 1/4	13.78	2.87	5.75	4.13	2.48	1.10	9.37	16.65	6.10	2.48	13.74	4.25	1.30	68

MBL = Minimum Breaking Load

- The standard finish of the sockets is blue primer coating and hot dipped galvanized (OWS 0,5 only galvanized)
- All sockets are provided with an EN 10204-2.1 declaration of conformity and EN 10204-3.1 material certificate.
- Dimensional tolerances are ±5% for the jaw opening (W) and pin diameter (øP).
- For other dimensional tolerances please contact Ropeblock.
- Surface finish e.g. hot dip galvanizing or paint may add to the overall thickness and fork distance.



**SEE OUR WARNING
& SAFETY INFORMATION
ON PAGES 136 - 149**

SEE OUR WARNING AND SAFETY INFORMATION ON PAGE 136

TAILGRIP OPEN WEDGE UTILITY SOCKET WITH PIN

NEW

QUENCHED AND TEMPERED CAST STEEL

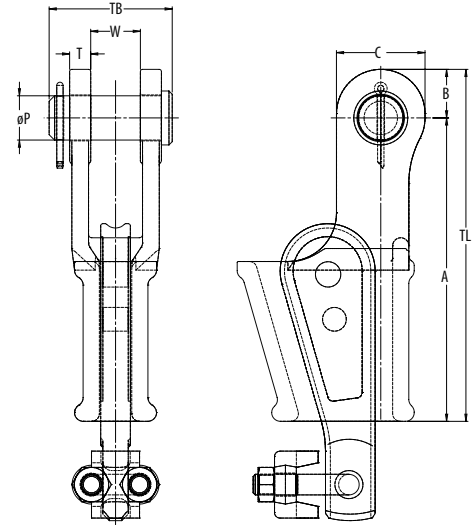
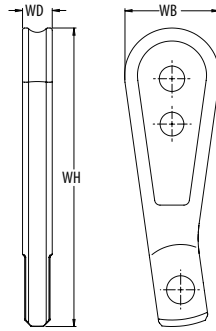

Model No.	MBL (USTons)	for wire ø		Dimensions (inch)											Weight (lbs)	
		(mm)	(inch)	A	B	C	øP	T	TL	TB	W	WH	WB	WD		
OWS-U 4.10 P	■	13	10	3/8	5.75	1.06	1.94	1.00	0.50	6.81	2.93	1.00	5.99	1.91	0.44	5
OWS-U 4.11 P	■	13	11	7/16	5.75	1.06	1.94	1.00	0.50	6.81	5.93	1.00	6.59	1.76	0.53	5
OWS-U 4.13 P	■	13	13	1/2	5.75	1.06	1.94	1.00	0.50	6.81	2.93	1.00	6.65	1.76	0.53	5
OWS-U 5.13 P	■	22	13	1/2	7.69	1.50	3.00	1.25	0.63	9.19	3.65	1.41	7.85	1.92	0.75	9
OWS-U 5.14 P	■	22	14	5/16	7.69	1.50	3.00	1.25	0.63	9.19	3.65	1.41	7.57	2.00	0.69	9
OWS-U 5.16 P	■	22	16	3/8	7.69	1.50	3.00	1.25	0.63	9.19	3.65	1.41	7.63	2.00	0.69	9
OWS-U 6.16 P*	■	38	16	5/8	8.46	1.50	3.00	1.25	0.57	9.96	3.74	1.50	7.68	2.36	0.83	13
OWS-U 6.19 P*	■	38	19	3/4	8.46	1.50	3.00	1.25	0.57	9.96	3.74	1.50	7.68	2.36	0.83	13
OWS-U 7-22 P	■	38	22	7/8	9.63	1.63	3.26	1.25	0.66	11.26	3.25	1.31	10.59	2.12	1.06	17
OWS-U 7-26 P	■	66	26	1	9.63	1.63	3.26	1.25	0.66	11.26	3.25	1.31	10.59	1.88	1.06	17
OWS-U 8A.16 P	■	38	16	5/8	8.98	1.54	2.87	1.63	0.77	10.51	4.53	1.81	8.84	2.95	0.83	19
OWS-U 8A.19 P	■	38	19	3/4	8.98	1.54	2.87	1.63	0.77	10.51	4.53	1.81	8.84	2.95	0.83	18
OWS-U 8.22 P*	■	66	22	7/8	11.06	1.77	3.23	1.63	0.77	12.83	4.49	1.81	10.89	3.46	1.08	28
OWS-U 8.26 P*	■	66	26	1	11.06	1.77	3.23	1.63	0.77	12.83	4.49	1.81	10.79	3.27	1.08	28
OWS-U 10.28 P*	■	99	28	1 1/8	13.74	2.20	4.33	1.63	0.89	15.94	4.72	1.81	13.82	4.41	1.30	53
OWS-U 10.32 P*	■	99	32	1 1/4	13.74	2.20	4.33	1.63	0.89	15.94	4.72	1.81	13.74	4.25	1.30	53
OWS-U 11.28 P	■	99	28	1 1/8	14.00	2.34	4.50	2.50	1.06	16.34	6.53	2.62	14.26	4.76	1.09	61
OWS-U 11.32 P	■	99	32	1 1/4	14.00	2.34	4.50	2.50	1.06	16.34	6.53	2.62	15.20	4.62	1.19	65

* AVAILABLE FROM STOCK

MBL = Minimum Breaking Load

- The standard finish of our sockets is ISO 12944 C3M RAL 1023.
- All sockets are provided with an EN 10204-2.1 declaration of conformity, EN 10204-3.1 material certificate.
- Dimensional tolerances are ±5% for the jaw opening (W) and pin diameter (øP).
For other dimensional tolerances please contact Ropeblock.
- Surface finish e.g. hot dip galvanizing or paint may add to the overall thickness and fork distance.
- Only use Ropeblock Utility wedges in combination with Ropeblock Utility wedge sockets.
- The wedges are colored for easy rope size identification.
 - : Smallest wire rope size
 - : Intermediate wire rope size
 - : Largest wire rope size



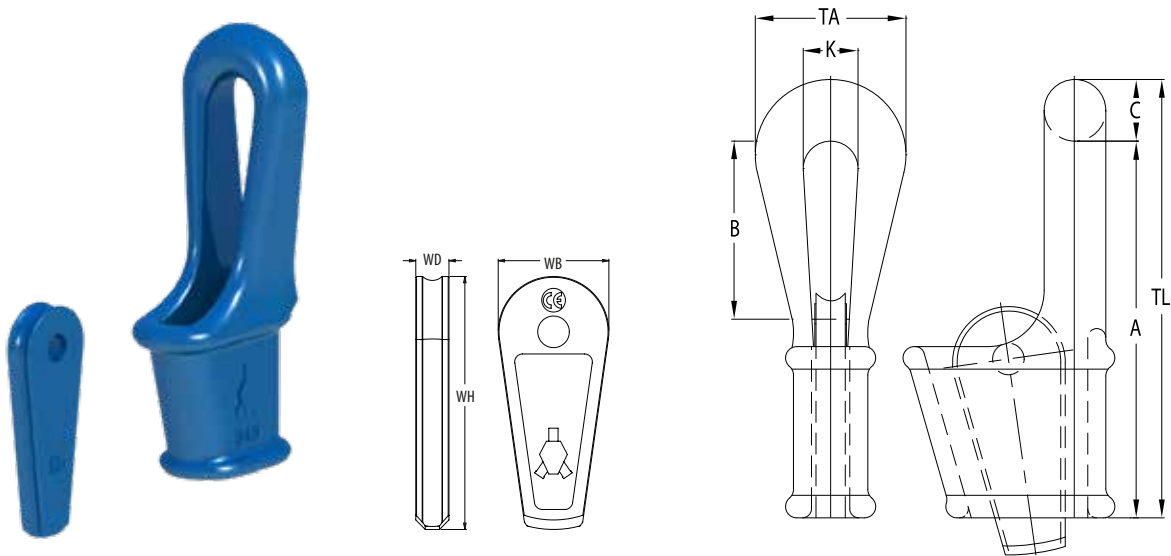

Model No.	MBL (UStons)	for wire ø		Dimensions (inch)									Weight (lbs)
		(mm)	(inch)	A	B	C	K	TA	TL	WH	WB	WD	
CWS 303	44	18-19	¾	8.66	3.94	1.34	1.57	3.54	10.00	6.30	2.76	0.83	15
CWS 304	61	20-22	7/8	8.86	4.92	1.65	1.85	4.33	10.51	7.34	3.03	0.94	20
CWS 305	83	24-26	1	11.42	5.12	1.97	2.17	4.92	13.39	8.33	3.27	1.08	31
CWS 306	99	27-29	1 1/8	12.80	5.71	2.36	2.76	5.98	15.16	9.11	3.58	1.18	49
CWS 307	121	30-32	1 1/4	14.17	6.30	2.68	2.95	6.50	16.85	10.47	4.25	1.30	66
CWS 308	138	34-36	1 3/8	15.75	7.09	2.68	2.95	6.50	18.43	11.73	4.57	1.38	84
CWS 309	165	37-39	1 1/2	19.69	9.45	2.83	3.15	7.28	22.52	13.31	5.12	1.50	108
CWS 310	187	40-42	1 5/8	23.62	12.20	3.15	3.54	8.27	26.77	14.67	5.51	1.61	143
CWS 311	248	43-48	1 3/4 - 1 7/8	25.20	12.80	3.54	3.94	8.86	28.74	16.06	5.75	1.89	220
CWS 312	309	49-52	2	28.35	14.76	3.94	4.33	9.65	32.28	17.72	6.30	2.09	331
CWS 313	397	54-58	2 1/4	30.51	15.75	4.33	4.72	10.43	34.84	18.50	6.61	2.28	353
CWS 314	468	61-64	2 1/2	35.43	18.50	4.92	5.12	11.81	40.35	19.69	6.93	2.56	507
CWS 315	507	72-76	3	39.37	16.73	5.12	5.91	12.99	44.49	21.65	9.61	2.76	794
CWS 316	689	81-86	3 1/4 - 3 3/8	44.29	21.65	5.31	6.50	14.17	49.61	26.38	10.24	3.15	937

MBL = Minimum Breaking Load

- The standard finish of the sockets is blue primer coating and hot dipped galvanized
- All sockets are provided with an EN 10204-2.1 declaration of conformity and EN 10204-3.1 material certificate.
- Dimensional tolerances are ±5% for the bow opening (K) and bow thickness (C).
- For other dimensional tolerances please contact Ropeblock.
- Surface finish e.g. hot dip galvanizing or paint may add to the overall thickness and fork distance.



SEE OUR WARNING & SAFETY INFORMATION ON PAGES 136 - 149



PORT INDUSTRY SOCKETS WITH BOLT AND NUT

NEW

QUENCHED AND TEMPERED CAST STEEL

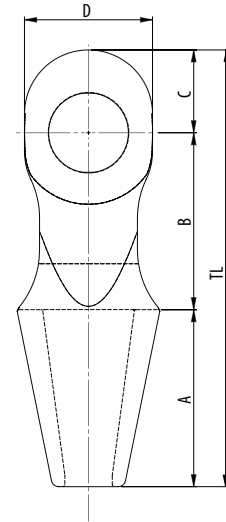
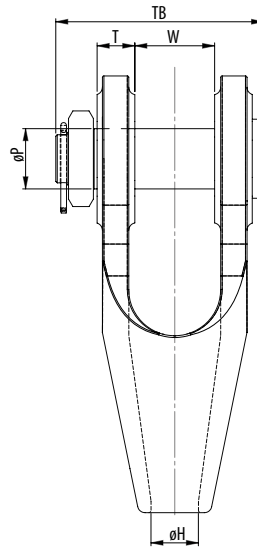

Model No.	MBL (UStons)	for wire ø		Dimensions (inch)										Weight (lbs)
		(mm)	(inch)	A	B	C	D	øH	øP	T	TL	TB	W	
OSS G5 B	132	28-30	1 1/8	5,39	5,31	2,17	1,97	1,42	1,99	1,30	12,87	6,77	2,48	24
OSS G6 B *	165	31-34	1 1/4 - 1 3/8	6,10	5,91	2,36	4,33	1,65	2,17	1,46	365	7,76	2,76	35
OSS G7 B	187	35-38	1 3/8 - 1 1/2	6,93	6,69	2,76	4,72	1,85	2,38	1,61	16,38	8,46	3,15	49
OSS G8 B	248	39-43	1 1/2 - 1 3/4	7,80	7,48	3,15	5,31	2,05	2,78	1,81	18,43	9,53	3,54	62
OSS G9 B *	309	44-54	1 3/4 - 2 1/8	9,25	9,25	4,33	6,69	2,48	3,15	1,97	22,83	10,87	4,17	130
OSS G10 B	397	50-60	2 1/4 - 2 1/2	10,43	9,65	4,72	7,48	2,83	3,58	2,17	24,80	9,29	4,96	143

* AVAILABLE FROM STOCK

MBL = Minimum Breaking Load

- The standard finish of the sockets is blue primer coating and hot dipped galvanized.
- All sockets are provided with an EN 10204-2.1 declaration of conformity and EN 10204-3.1 material certificate.
- Dimensional tolerances are ±5% for the jaw opening (W) and pin diameter (øP).
- For other dimensional tolerances please contact Ropeblock.
- Surface finish e.g. hot dip galvanizing or paint may add to the overall thickness and fork distance.



SEE OUR WARNING & SAFETY INFORMATION ON PAGES 136 - 149

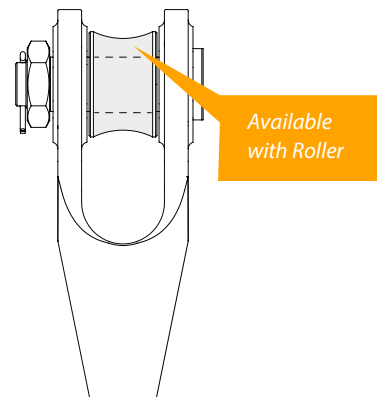

PORT INDUSTRY SOCKETS WITH PIN

NEW

QUENCHED AND TEMPERED CAST STEEL

SOCKETS

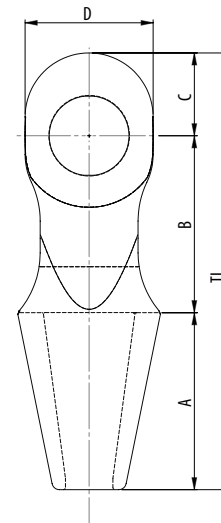
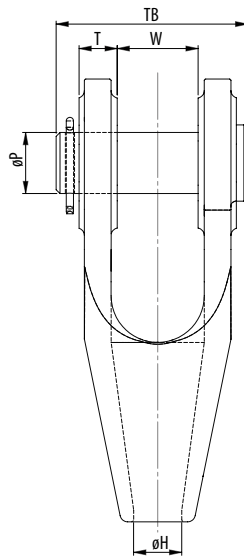

Model No.	MBL (UStons)	for wire ø		Dimensions (inch)										Weight (lbs)
		(mm)	(inch)	A	B	C	D	øH	øP	T	TL	TB	W	
OSS G5 P	132	28-30	1 1/8	5,39	5,31	2,17	1,97	1,42	1,99	1,30	12,87	6,77	2,48	24
OSS G6 P *	165	31-34	1 1/4 - 1 3/8	6,10	5,91	2,36	4,33	1,65	2,17	1,46	365	7,76	2,76	35
OSS G7 P	187	35-38	1 3/8 - 1 1/2	6,93	6,69	2,76	4,72	1,85	2,38	1,61	16,38	8,46	3,15	49
OSS G8 P	248	39-43	1 1/2 - 1 3/4	7,80	7,48	3,15	5,31	2,05	2,78	1,81	18,43	9,53	3,54	62
OSS G9 P *	309	44-54	1 3/4 - 2 1/8	9,25	9,25	4,33	6,69	2,48	3,15	1,97	22,83	10,87	4,17	130
OSS G10 P	397	50-60	2 1/4 - 2 1/2	10,43	9,65	4,72	7,48	2,83	3,58	2,17	24,80	9,29	4,96	143

* AVAILABLE FROM STOCK

MBL = Minimum Breaking Load

- The standard finish of the sockets is blue primer coating and hot dipped galvanized.
- All sockets are provided with an EN 10204-2.1 declaration of conformity and EN 10204-3.1 material certificate.
- Dimensional tolerances are ±5% for the jaw opening (W) and pin diameter (øP).
- For other dimensional tolerances please contact Ropeblock.
- Surface finish e.g. hot dip galvanizing or paint may add to the overall thickness and fork distance.



SEE OUR WARNING & SAFETY INFORMATION ON PAGES 136 - 149

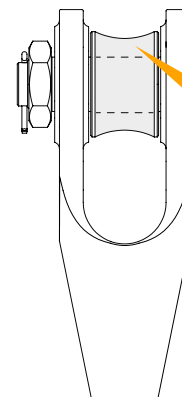

Available with Roller

SEE OUR WARNING AND SAFETY INFORMATION ON PAGE 136



OPEN SPELTER SOCKETS JIS WITH BOLT

QUENCHED AND
TEMPERED CAST STEEL

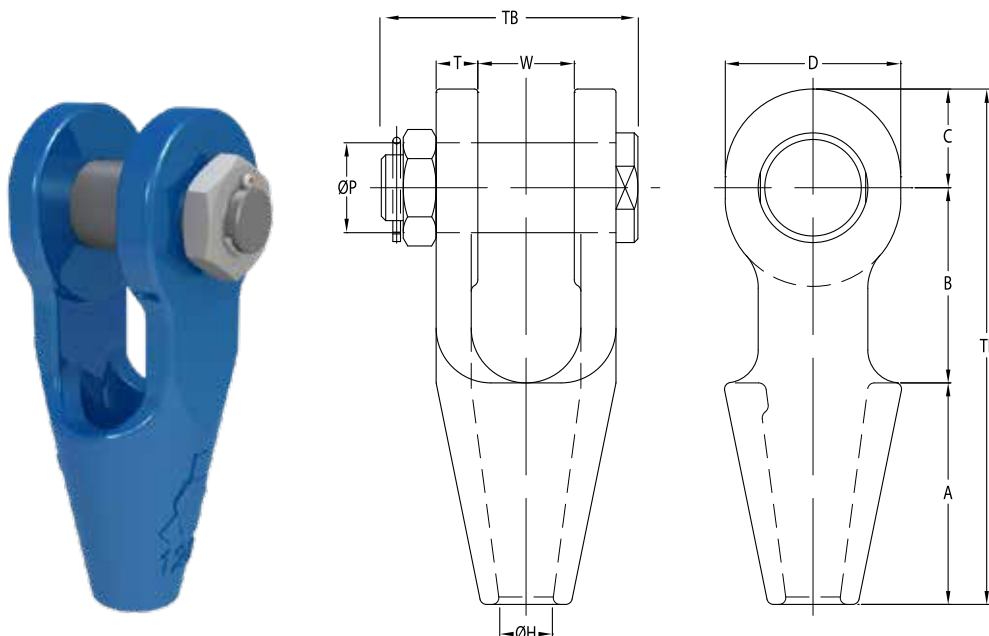

Model No.	MBL (UStons)	for wire ø		Dimensions (inch)										Weight (lbs)
		(mm)	(inch)	A	B	C	D	øH	øP	T	TL	TB	W	
OSS 100-J20-B30	31	18-19	¾	3.50	2.99	1.57	2.76	0.83	1.18	0.63	8.07	4.21	1.50	6.6
OSS 104-J22-B34	39	20-22,4	7/8	3.98	3.50	1.77	3.15	0.94	1.34	0.75	9.25	4.84	1.73	9.7
OSS 108-J24-B37	45	23-26	1	4.49	3.98	2.36	4.09	1.10	1.46	0.87	10.83	5.43	2.01	18
OSS 108-J25-B40	57	23-26	1	4.49	3.98	2.36	4.09	1.10	1.57	0.87	10.83	5.43	2.01	18
OSS 111-J28-B43	62	27-30	1 1/8	5.00	4.49	2.56	4.49	1.26	1.69	0.98	12.05	6.30	2.24	25
OSS 111-J30-B46	76	27-30	1 1/8	5.00	4.49	2.56	4.49	1.26	1.81	0.98	12.05	6.30	2.24	25.6
OSS 115-J32-B48	76	31-36	1 1/4 - 1 3/8	5.47	5.00	2.83	4.96	1.50	1.89	1.10	13.31	6.85	2.48	33
OSS 115-J34-B52	97	31-36	1 1/4 - 1 3/8	5.47	5.00	2.83	4.96	1.50	2.05	1.10	13.31	6.85	2.48	33.5
OSS 118-J36-B56	104	35,5-39	1 1/2	5.98	6.38	3.15	5.59	1.61	2.20	1.18	15.51	7.91	2.99	48.5

MBL = Minimum Breaking Load

- The standard finish of the sockets is blue primer coating and hot dipped galvanized.
- All sockets are provided with an EN 10204-2.1 declaration of conformity and EN 10204-3.1 material certificate.
- Dimensional tolerances are ±5% for the jaw opening (W) and pin diameter (øP).
- For other dimensional tolerances please contact Ropeblock.
- Surface finish e.g. hot dip galvanizing or paint may add to the overall thickness and fork distance.

 **SEE OUR WARNING & SAFETY INFORMATION ON PAGES 136 - 148**





CUSTOMIZED SOCKET SOLUTIONS

The standard range of Ropeblock sockets covers the majority of customer needs for terminating a wire rope. However, in some cases the standard will not do.

This is where our engineered solutions can come into place. The possibilities are virtually unlimited and therefore this is merely a snapshot of what can be done:

- Customization in material properties: Stainless steel, polished chrome finish and alternative materials.
- Additional features: integrated thrust bearing for swivelling, special interfaces, aesthetic features.
- Specific applications: bridge spelter sockets, in pin integrated load cell, increased MBL requirements, etcetera.

**CONTACT US TO EXPLORE
THE ENDLESS POSSIBILITIES**



*Subsea swivel socket,
MBL 600 Mtons.*

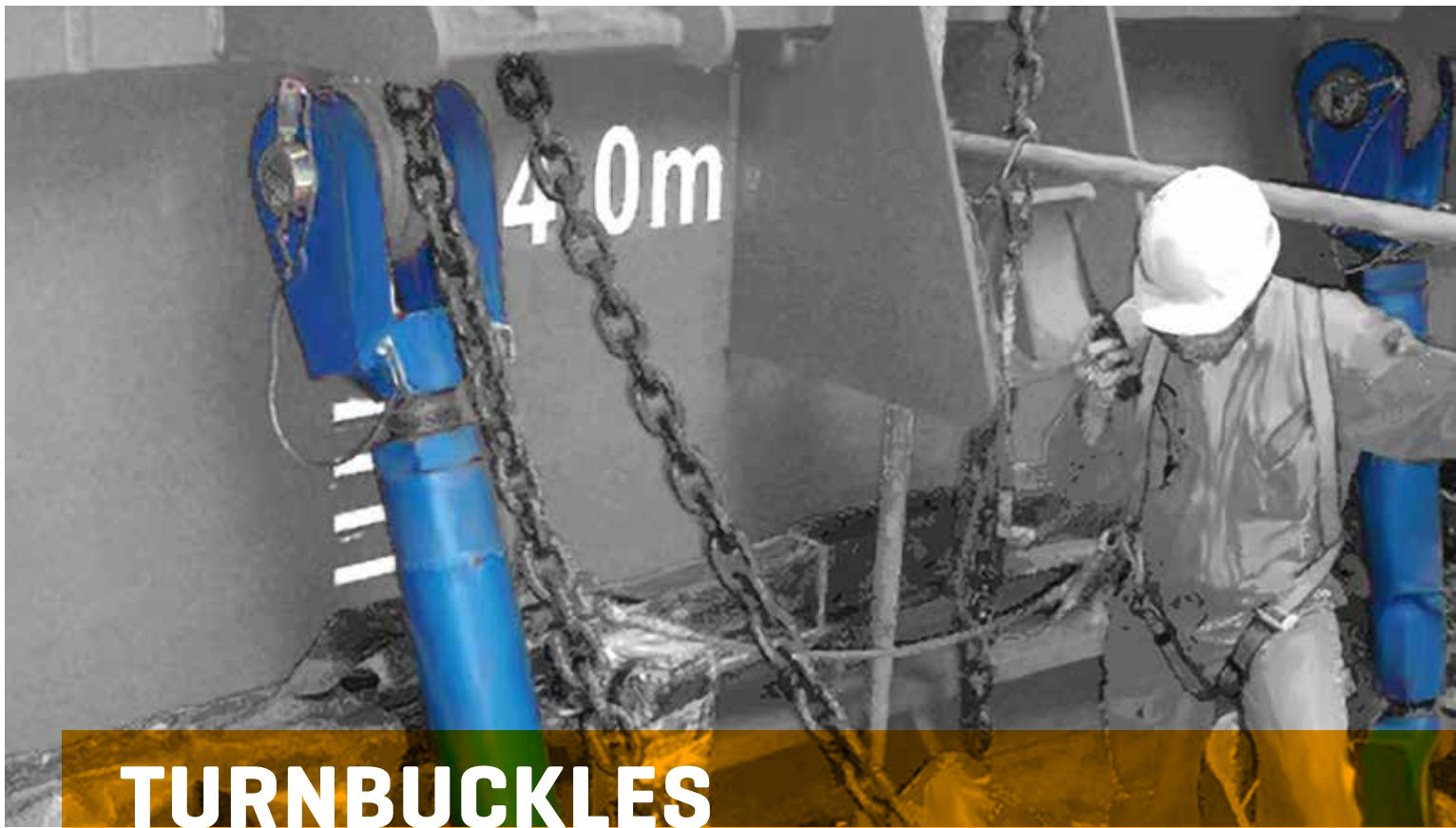

TURNBUCKLES WITH TRAPEZOID THREAD

Ropeblock's standard turnbuckles allow for working loads ranging from 1 to 160 tons. They are available in all possible combinations of jaws, round eyes and oval eyes (no stub ends!). In standard design, the dimensions of the trapezoid thread turnbuckles generally are in accordance with NEN 3305.

Standard features include:

- Standard finish: primer coating blue RAL 5017. Other finishes, including coatings in accordance with ISO 12944 specifications, are available on request.
- Standard with locking nuts. Locking plates, locking bolts and other locking devices are available on request.
- Turnbuckles can be supplied with turning wheel or ratchet on request.
- Sizes other than standard are possible on request.

WE WELCOME ALL ENQUIRIES FOR CUSTOM DESIGNED SOLUTIONS. PLEASE CONTACT YOUR SALES REPRESENTATIVE FOR FURTHER INFORMATION.



TURNBUCKLES WITH TRAPEZOID THREAD; JAW - JAW

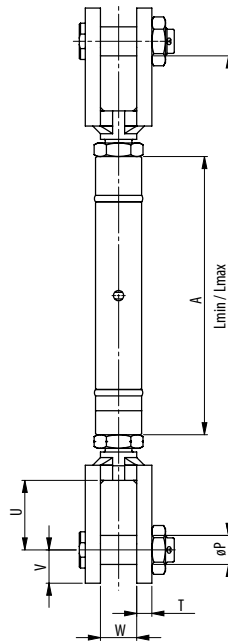

Model No.	WLL (UStons)	L min (inch)	L max (inch)	Take-up (inch)	Thread (trap.)	Dimensions (inch)						Weight (lbs)
						A	øP	U	V	W	T	
SPS TR.22.188.1,6J-J	1.7	15.67	22.24	6.57	22 x 5	9.45	0.79	2.17	0.89	0.91	0.43	7
SPS TR.24.200.2J-J	2.2	16.61	23.74	7.13	24 x 5	10.24	0.87	2.28	0.98	1.02	0.47	9
SPS TR.28.206.2,5J-J	2.7	20.16	28.62	8.46	28 x 5	11.02	0.94	2.87	1.08	1.18	0.47	13
SPS TR.30.228.3,1J-J	3.4	21.38	30.24	8.86	30 x 6	11.81	1.06	3.15	1.18	1.26	0.59	20
SPS TR.32.241.4J-J	4.4	22.99	32.13	9.13	32 x 6	12.60	1.18	3.39	1.28	1.38	0.59	22
SPS TR.36.240.5J-J	5.5	24.09	33.62	9.53	36 x 6	13.39	1.42	3.66	1.48	1.57	0.79	33
SPS TR.44.263.6,3J-J	6.9	27.60	38.23	10.63	44 x 7	14.96	1.54	4.25	1.67	1.77	0.79	44
SPS TR.48.297.8J-J	8.8	29.72	41.38	11.65	48 x 8	16.54	1.77	4.41	1.87	1.97	0.98	62
SPS TR.52.309.10J-J	11.0	31.42	43.46	12.05	52 x 8	18.11	1.89	4.53	2.17	2.36	0.98	77
SPS TR.55.340.12,6J-J	13.8	33.94	47.80	13.86	55 x 9	19.69	2.05	4.80	2.36	2.56	1.18	104
SPS TR.65.354.16J-J	17.6	37.17	51.57	14.41	65 x 10	21.26	2.36	5.12	2.56	2.76	1.18	137
SPS TR.70.382.20J-J	22.0	41.02	55.98	14.96	70 x 10	22.83	2.68	5.71	2.76	2.95	1.38	187
SPS TR.75.404.25J-J	27.5	44.33	60.16	15.83	75 x 10	24.41	2.83	6.30	2.95	3.15	1.38	220
SPS TR.80.430.31,5J-J	34.7	46.93	64.17	17.24	80 x 10	25.98	3.15	6.69	3.35	3.54	1.57	287
SPS TR.90.495.40J-J	44.0	50.39	68.66	18.27	90 x 10	27.36	3.54	7.48	3.62	3.94	1.77	386
SPS TR.100.550.50J-J	55.1	54.72	75.20	20.47	100 x 10	30.31	3.94	8.07	4.13	4.33	1.97	520
SPS TR.110.605.63J-J	69.4	60.08	82.28	22.20	110 x 10	33.66	4.33	8.66	4.41	4.72	2.36	717
SPS TR.120.660.80J-J	88.1	65.08	89.88	24.80	120 x 10	36.22	4.92	9.25	5.00	5.51	2.76	996
SPS TR.130.715.100J-J	110.2	68.82	97.17	28.35	130 x 10	39.17	5.51	9.84	5.59	6.14	2.76	1272
SPS TR.140.770.125J-J	137.7	74.80	104.41	29.61	140 x 10	42.13	6.30	10.63	6.38	6.93	3.15	1788
SPS TR.160.880.160J-J	176.3	82.28	116.93	34.65	160 x 10	48.03	7.09	11.42	7.17	7.87	3.54	2469

Minimum Ultimate Strength = 5 x WLL

- Standard painted blue, but can be supplied in any color or galvanized.
- Available in all combinations of eyes, stud eyes and welding ends.
- Factory supplied with lock nuts.
- Lock plates or special locking devices possible.
- Can be supplied with turning wheel or ratchet.
- Other sizes possible.
- Straight or in-line pull only.



TURNBUCKLES WITH TRAPEZOID THREAD; STUD EYE - STUD EYE

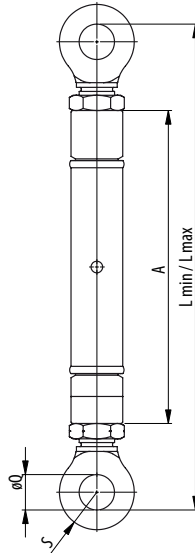

Model No.	WLL (UStons)	L min (inch)	L max (inch)	Take-up (inch)	Thread (trap.)	Dimensions (inch)				Weight (lbs)
						A	øQ	S	T	
SPS TR.22.188.1,6.E-E	1.7	13.74	20.31	6.57	22 x 5	9.45	0.91	0.89	0.79	4
SPS TR.24.200.2.E-E	2.2	14.84	21.97	7.13	24 x 5	10.24	0.98	0.98	0.87	7
SPS TR.28.206.2,5.E-E	2.7	16.18	24.65	8.46	28 x 5	11.02	1.06	1.08	0.98	11
SPS TR.30.228.3,1.E-E	3.4	17.91	26.77	8.86	30 x 6	11.81	1.18	1.18	1.10	11
SPS TR.32.241.4.E-E	4.4	18.66	27.80	9.13	32 x 6	12.60	1.30	1.28	1.18	13
SPS TR.36.240.5.E-E	5.5	21.10	30.63	9.53	36 x 6	13.39	1.54	1.48	1.38	24
SPS TR.44.263.6,3.E-E	6.9	22.80	33.43	10.63	44 x 7	14.96	1.65	1.67	1.57	26
SPS TR.48.297.8.E-E	8.8	25.87	37.52	11.65	48 x 8	16.54	1.89	1.87	1.77	35
SPS TR.52.309.10.E-E	11.0	28.11	40.16	12.05	52 x 8	18.11	2.05	2.17	1.97	51
SPS TR.55.340.12,6.E-E	13.8	30.00	43.86	13.86	55 x 9	19.69	2.20	2.36	2.17	88
SPS TR.65.354.16.E-E	17.6	33.86	48.27	14.41	65 x 10	21.26	2.56	2.56	2.36	121
SPS TR.70.382.20.E-E	22.0	35.59	50.55	14.96	70 x 10	22.83	2.91	2.76	2.56	152
SPS TR.75.404.25.E-E	27.5	38.27	54.09	15.83	75 x 10	24.41	3.07	2.95	2.76	137
SPS TR.80.430.31,5.E-E	34.7	40.87	58.11	17.24	80 x 10	25.98	3.39	3.35	3.15	172
SPS TR.90.495.40.E-E	44.0	46.69	64.96	18.27	90 x 10	27.36	3.78	3.74	3.54	300
SPS TR.100.550.50.E-E	55.1	50.63	71.10	20.47	100 x 10	30.31	4.17	4.13	3.94	353
SPS TR.110.605.63.E-E	69.4	55.35	77.56	22.20	110 x 10	33.27	4.57	4.53	4.33	485
SPS TR.120.660.80.E-E	88.1	60.67	85.47	24.80	120 x 10	36.22	5.16	5.31	4.92	617
SPS TR.130.715.100.E-E	110.2	65.43	93.78	28.35	130 x 10	39.17	5.75	5.83	5.51	816
SPS TR.140.770.125.E-E	137.7	71.02	100.63	29.61	140 x 10	42.13	6.61	6.61	6.30	1102
SPS TR.160.880.160.E-E	176.3	79.84	114.49	34.65	160 x 10	48.03	7.40	7.48	7.09	1598

Minimum Ultimate Strength = 5 x WLL

- Standard painted blue, but can be supplied in any color or galvanized.
- Available in all combinations of eyes, stud eyes and welding ends.
- Factory supplied with lock nuts.
- Lock plates or special locking devices possible.
- Can be supplied with turning wheel or ratchet.
- Other sizes possible.
- Straight or in-line pull only.



SEE OUR WARNING
& SAFETY INFORMATION
ON PAGES 136 - 149



TURNBUCKLES WITH TRAPEZOID THREAD; JAW - STUD EYE

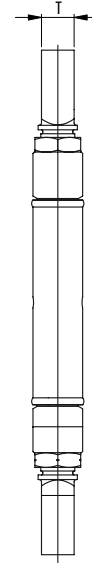
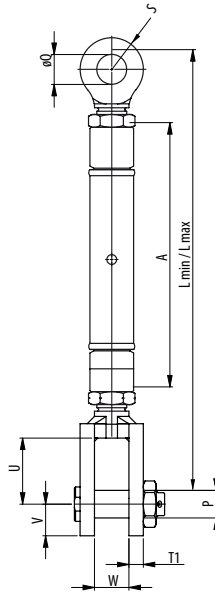

Model No.	WLL (UStons)	L min (inch)	L max (inch)	Take-up (inch)	Thread (trap.)	Dimensions (inch)								Weight (lbs)	
						A	øP	øQ	S	T	T1	U	V		W
SPS TR.22.188.1,6J-E	1.7	14.45	21.02	6.57	22 x 5	9.45	0.79	0.91	0.89	0.79	2.17	0.87	0.91	23	4
SPS TR.24.200.2J-E	2.2	15.55	22.68	7.13	24 x 5	10.24	0.87	0.98	0.98	0.87	2.28	0.98	1.02	26	7
SPS TR.28.206.2,5J-E	2.7	18.07	26.54	8.46	28 x 5	11.02	0.94	1.06	1.08	0.98	2.87	1.06	1.18	30	11
SPS TR.30.228.3,1J-E	3.4	19.65	28.50	8.86	30 x 6	11.81	1.06	1.18	1.18	1.10	3.15	1.18	1.26	32	15
SPS TR.32.241.4J-E	4.4	20.83	29.96	9.13	32 x 6	12.60	1.18	1.30	1.28	1.18	3.39	1.26	1.38	35	18
SPS TR.36.240.5J-E	5.5	22.60	32.13	9.53	36 x 6	13.39	1.42	1.54	1.48	1.38	3.66	1.46	1.57	40	26
SPS TR.44.263.6,3J-E	6.9	25.20	35.83	10.63	44 x 7	14.96	1.54	1.65	1.67	1.57	4.25	1.65	1.77	45	35
SPS TR.48.297.8J-E	8.8	27.80	39.45	11.65	48 x 8	16.54	1.77	1.89	1.87	1.77	4.41	1.85	1.97	50	49
SPS TR.52.309.10J-E	11.0	29.76	41.81	12.05	52 x 8	18.11	1.89	2.05	2.17	1.97	4.53	2.17	2.36	60	64
SPS TR.55.340.12,6J-E	13.8	31.97	45.83	13.86	55 x 9	19.69	2.05	2.20	2.36	2.17	4.80	2.36	2.56	65	97
SPS TR.65.354.16J-E	17.6	35.51	49.92	14.41	65 x 10	21.26	2.36	2.56	2.56	2.36	5.12	2.56	2.76	70	112
SPS TR.70.382.20J-E	22.0	37.68	52.64	14.96	70 x 10	22.83	2.68	2.91	2.76	2.56	5.71	2.76	2.95	75	163
SPS TR.75.404.25J-E	27.5	41.30	57.13	15.83	75 x 10	24.41	2.83	3.07	2.95	2.76	6.30	2.95	3.15	80	179
SPS TR.80.430.31,5J-E	34.7	43.90	61.14	17.24	80 x 10	25.98	3.15	3.39	3.35	3.15	6.69	3.35	3.54	90	229
SPS TR.90.495.40J-E	44.0	48.43	66.69	18.27	90 x 10	27.36	3.54	3.78	3.74	3.54	7.48	3.62	3.94	100	344
SPS TR.100.550.50J-E	55.1	52.56	73.03	20.47	100 x 10	30.31	3.94	4.17	4.13	3.94	8.07	4.13	4.33	110	441
SPS TR.110.605.63J-E	69.4	57.60	79.80	22.20	110 x 10	33.66	4.33	4.57	4.53	4.33	8.66	4.41	4.72	120	639
SPS TR.120.660.80J-E	88.1	62.76	87.56	24.80	120 x 10	36.22	4.92	5.16	5.31	4.92	9.25	5.00	5.51	140	772
SPS TR.130.715.100J-E	110.2	67.01	95.35	28.35	130 x 10	39.17	5.51	5.75	5.83	5.51	9.84	5.59	6.14	156	970
SPS TR.140.770.125J-E	137.7	72.36	101.97	29.61	140 x 10	42.13	6.30	6.61	6.61	6.30	10.63	6.38	6.93	176	1455
SPS TR.160.880.160J-E	176.3	80.94	115.59	34.65	160 x 10	48.03	7.09	7.40	7.48	7.09	11.42	7.17	7.87	200	2039

Minimum Ultimate Strength = 5 x WLL

- Standard painted blue, but can be supplied in any color or galvanized.
- Available in all combinations of eyes, stud eyes and welding ends.
- Factory supplied with lock nuts.
- Lock plates or special locking devices possible.
- Can be supplied with turning wheel or ratchet.
- Other sizes possible.
- Straight or in-line pull only.



TURNBUCKLES WITH TRAPEZOID THREAD; OBLONG EYE - OBLONG EYE

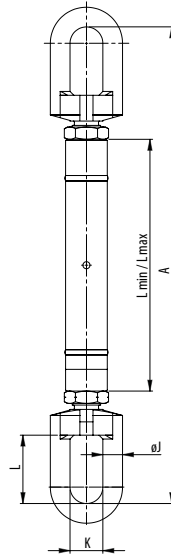

Model No.	WLL (UStons)	L min (inch)	L max (inch)	Take-up (inch)	Thread (trap.)	Dimensions (inch)				Weight (lbs)
						A	øJ	K	L	
SPS TR.22.188.1,6,O-O	1.7	17.72	24.29	6.57	22 x 5	9.45	0.63	1.02	2.28	4
SPS TR.24.200.2,O-O	2.2	18.50	25.63	7.13	24 x 5	10.24	0.63	1.02	2.28	7
SPS TR.28.206.2,5,O-O	2.7	21.02	29.49	8.46	28 x 5	11.02	0.79	1.26	2.83	11
SPS TR.30.228.3,1,O-O	3.4	21.81	30.67	8.86	30 x 6	11.81	0.79	1.26	2.83	13
SPS TR.32.241.4,O-O	4.4	24.80	33.94	9.13	32 x 6	12.60	0.98	1.57	3.70	18
SPS TR.36.240.5,O-O	5.5	25.91	35.43	9.53	36 x 6	13.39	0.98	1.57	3.70	29
SPS TR.44.263.6,3,O-O	6.9	29.65	40.28	10.63	44 x 7	14.96	1.18	1.77	4.25	42
SPS TR.48.297.8,O-O	8.8	32.01	43.66	11.65	48 x 8	16.54	1.26	1.97	4.53	60
SPS TR.52.309.10,O-O	11.0	34.09	46.14	12.05	52 x 8	18.11	1.42	2.36	4.92	55
SPS TR.55.340.12,6,O-O	13.8	38.90	52.76	13.86	55 x 9	19.69	1.57	2.56	5.67	101
SPS TR.65.354.16,O-O	17.6	42.13	56.54	14.41	65 x 10	21.26	1.77	2.76	6.42	106
SPS TR.70.382.20,O-O	22.0	45.51	60.47	14.96	70 x 10	22.83	2.17	2.95	6.61	143
SPS TR.75.404.25,O-O	27.5	50.00	65.83	15.83	75 x 10	24.41	2.36	3.15	7.56	198
SPS TR.80.430.31,5,O-O	34.7	53.46	70.71	17.24	80 x 10	25.98	2.36	3.54	8.50	207

Minimum Ultimate Strength = 5 x WLL

- Standard painted blue, but can be supplied in any color or galvanized.
- Available in all combinations of eyes, stud eyes and welding ends.
- Factory supplied with lock nuts.
- Lock plates or special locking devices possible.
- Can be supplied with turning wheel or ratchet.
- Other sizes possible.
- Straight or in-line pull only.



TURNBUCKLES WITH TRAPEZOID THREAD; JAW - OBLONG EYE

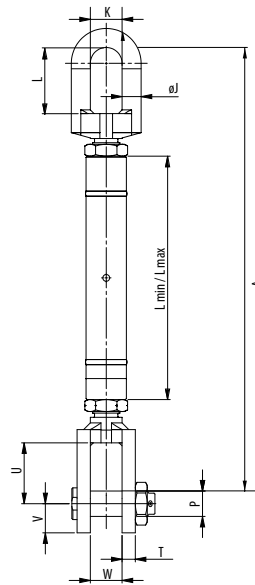

Model No.	WLL (UStons)	L min (inch)	L max (inch)	Take-up (inch)	Thread (trap.)	Dimensions (inch)								Weight (lbs)	
						A	J	K	L	øP	T	U	V		W
SPS TR.22.188.1,6J-O	1.7	16.42	22.99	6.57	22 x 5	9.45	0.63	1.02	2.28	0.79	2.17	0.89	0.91	23	7
SPS TR.24.200.2J-O	2.2	17.36	24.49	7.13	24 x 5	10.24	0.63	1.02	2.28	0.87	2.28	0.98	1.02	26	9
SPS TR.28.206.2,5J-O	2.7	20.59	29.06	8.46	28 x 5	11.02	0.79	1.26	2.83	0.94	2.87	1.08	1.18	30	13
SPS TR.30.228.3,1J-O	3.4	21.61	30.47	8.86	30 x 6	11.81	0.79	1.26	2.83	1.06	3.15	1.18	1.26	32	15
SPS TR.32.241.4J-O	4.4	23.90	33.03	9.13	32 x 6	12.60	0.98	1.57	3.70	1.18	3.39	1.28	1.38	35	20
SPS TR.36.240.5J-O	5.5	24.96	34.49	9.53	36 x 6	13.39	0.98	1.57	3.70	1.42	3.66	1.48	1.57	40	31
SPS TR.44.263.6,3J-O	6.9	28.50	39.13	10.63	44 x 7	14.96	1.18	1.77	4.25	1.54	4.25	1.67	1.77	45	44
SPS TR.48.297.8J-O	8.8	30.63	42.28	11.65	48 x 8	16.54	1.26	1.97	4.53	1.77	4.41	1.87	1.97	50	64
SPS TR.52.309.10J-O	11.0	32.76	44.80	12.05	52 x 8	18.11	1.42	2.36	4.92	1.89	4.53	2.17	2.36	60	66
SPS TR.55.340.12,6J-O	13.8	36.42	50.28	13.86	55 x 9	19.69	1.57	2.56	5.67	2.05	4.80	2.36	2.56	65	106
SPS TR.65.354.16J-O	17.6	39.65	54.06	14.41	65 x 10	21.26	1.77	2.76	6.42	2.36	5.12	2.56	2.76	70	121
SPS TR.70.382.20J-O	22.0	43.27	58.23	14.96	70 x 10	22.83	2.17	2.95	6.61	2.68	5.71	2.76	2.95	75	165
SPS TR.75.404.25J-O	27.5	46.34	62.17	15.83	75 x 10	24.41	2.36	3.15	7.56	2.83	6.30	2.95	3.15	80	207
SPS TR.80.430.31,5J-O	34.7	50.20	67.44	17.24	80 x 10	25.98	2.36	3.54	8.50	3.15	6.69	3.35	3.54	90	247

Minimum Ultimate Strength = 5 x WLL

- Standard painted blue, but can be supplied in any color or galvanized.
- Available in all combinations of eyes, stud eyes and welding ends.
- Factory supplied with lock nuts.
- Lock plates or special locking devices possible.
- Can be supplied with turning wheel or ratchet.
- Other sizes possible.
- Straight or in-line pull only.



SEE OUR WARNING
& SAFETY INFORMATION
ON PAGES 136 - 149

TURNBUCKLES WITH TRAPEZOID THREAD; OBLONG EYE - STUD EYE

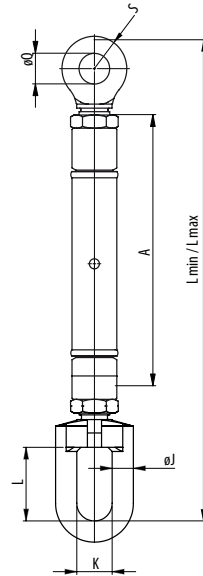

Model No.	WLL (USTons)	L min (inch)	L max (inch)	Take-up (inch)	Thread (trap.)	Dimensions (inch)							Weight (lbs)
						A	øJ	K	L	øQ	S	T	
SPS TR.22.188.1,6.O-E	1.7	15.75	22.32	6.57	22 x 5	9.45	0.63	1.02	2.28	0.91	0.89	0.79	4
SPS TR.24.200.2.O-E	2.2	16.69	23.82	7.13	24 x 5	10.24	0.63	1.02	2.28	0.98	0.98	0.87	7
SPS TR.28.206.2,5.O-E	2.7	18.70	27.17	8.46	28 x 5	11.02	0.79	1.26	2.83	1.06	1.08	0.98	11
SPS TR.30.228.3,1.O-E	3.4	19.88	28.74	8.86	30 x 6	11.81	0.79	1.26	2.83	1.18	1.18	1.10	13
SPS TR.32.241.4.O-E	4.4	21.73	30.87	9.13	32 x 6	12.60	0.98	1.57	3.70	1.30	1.28	1.18	15
SPS TR.36.240.5.O-E	5.5	23.03	32.56	9.53	36 x 6	13.39	0.98	1.57	3.70	1.54	1.48	1.38	26
SPS TR.44.263.6,3.O-E	6.9	26.18	36.81	10.63	44 x 7	14.96	1.18	1.77	4.25	1.65	1.67	1.57	37
SPS TR.48.297.8.O-E	8.8	28.50	40.16	11.65	48 x 8	16.54	1.26	1.97	4.53	1.89	1.87	1.77	55
SPS TR.52.309.10.O-E	11.0	31.10	43.15	12.05	52 x 8	18.11	1.42	2.36	4.92	2.05	2.17	1.97	53
SPS TR.55.340.12,6.O-E	13.8	34.45	48.31	13.86	55 x 9	19.69	1.57	2.56	5.67	2.20	2.36	2.17	93
SPS TR.65.354.16.O-E	17.6	37.99	52.40	14.41	65 x 10	21.26	1.77	2.76	6.42	2.56	2.56	2.36	97
SPS TR.70.382.20.O-E	22.0	41.10	56.06	14.96	70 x 10	22.83	2.17	2.95	6.61	2.91	2.76	2.56	157
SPS TR.75.404.25.O-E	27.5	44.06	59.88	15.83	75 x 10	24.41	2.36	3.15	7.56	3.07	2.95	2.76	181
SPS TR.80.430.31,5.O-E	34.7	47.17	64.41	17.24	80 x 10	25.98	2.36	3.54	8.50	3.39	3.35	3.15	190

Minimum Ultimate Strength = 5 x WLL

- Standard painted blue, but can be supplied in any color or galvanized.
- Available in all combinations of eyes, stud eyes and welding ends.
- Factory supplied with lock nuts.
- Lock plates or special locking devices possible.
- Can be supplied with turning wheel or ratchet.
- Other sizes possible.
- Straight or in-line pull only.



SEE OUR WARNING & SAFETY INFORMATION ON PAGES 136 - 149





COMPONENTS

The Ropeblock portfolio includes a wide choice of proven quality components for various lifting & rigging purposes, such as split overhaul balls, triangle plates and pad eyes. These components come in all current sizes and weight categories and are mostly available from stock.

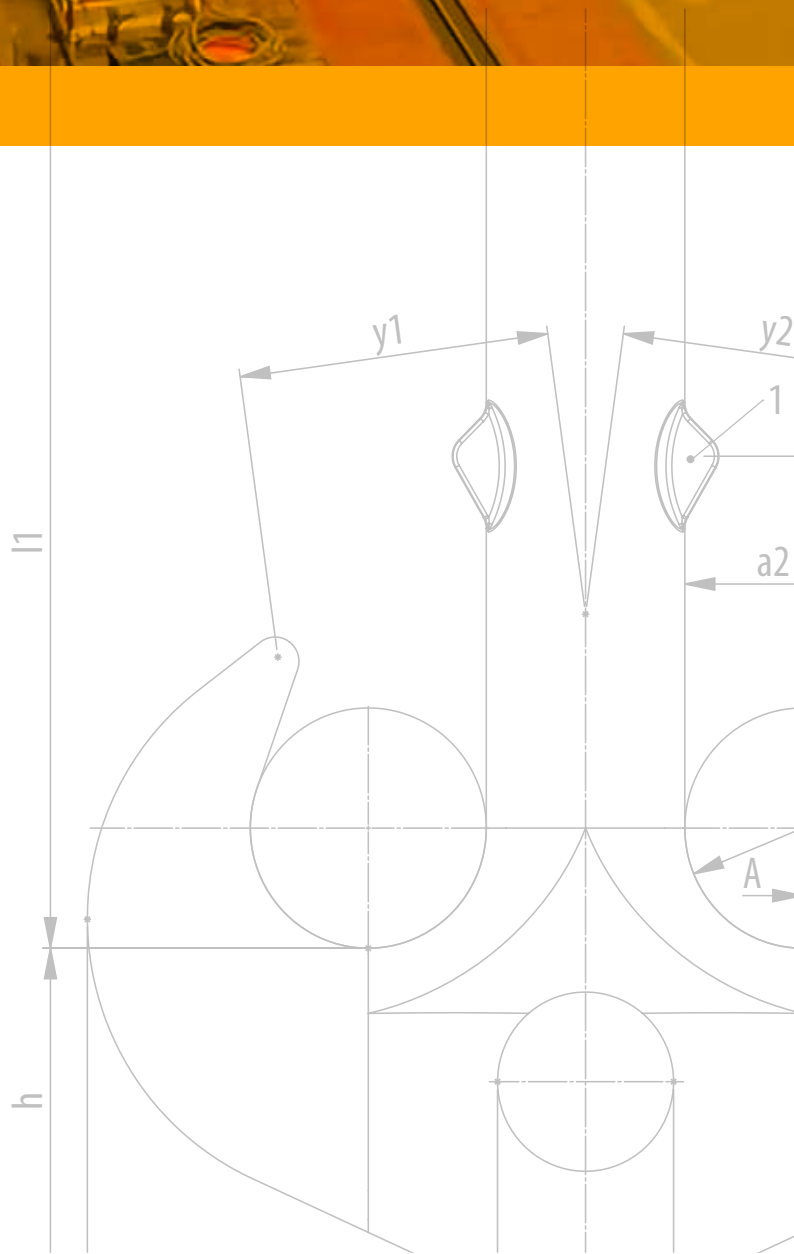

SINGLE HOOK

ACCORDING TO EN 13001-3-5 ANNEX A1 & A2
[PREVIOUSLY DIN 15401]

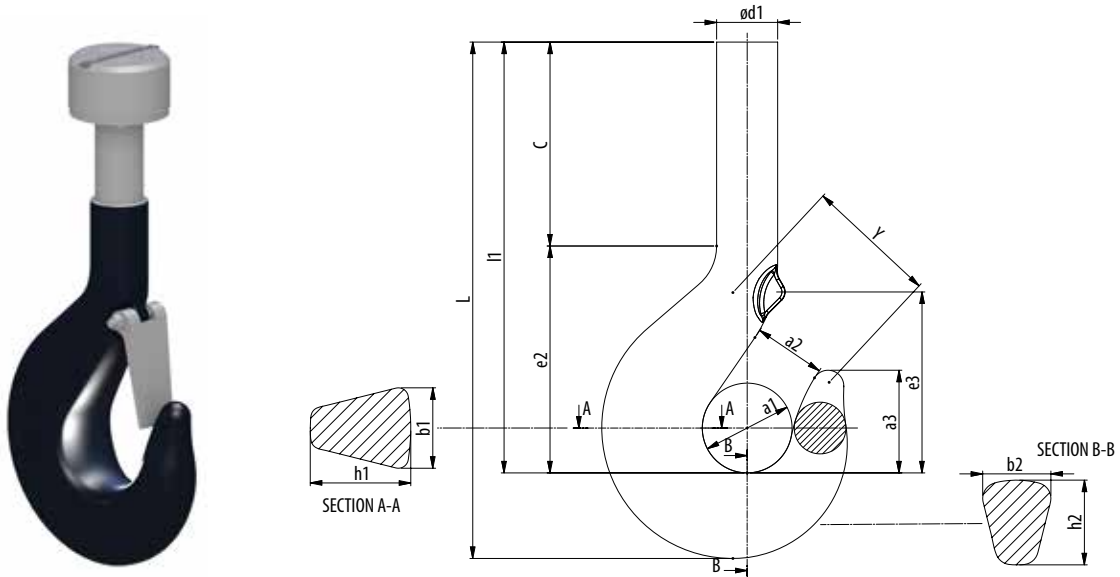

Hook No.	Lifting capacity (UStons)			Dimensions (inch)															Weight (lbs)
	V-Class	T-class	P-class	a1	a2	a3	b1	b2	c	ød1	e2	e3	h1	h2	L	l1	Y		
1.6	8	6,3	4	2.20	1.77	2.52	1.77	1.50	2.52	1.42	5.75	4.65	2.20	1.89	10.47	8.27	2.95	9.9	
2.5	12,5	10	6,3	2.48	1.97	2.83	2.09	1.77	3.46	1.65	6.57	5.20	2.64	2.28	12.68	10.04	3.15	13.7	
4	20	16	10	2.80	2.20	3.15	2.48	2.09	5.51	1.89	7.48	5.83	3.15	2.64	16.14	12.99	5.12	21.8	
5	25	20	12,5	3.15	2.48	3.54	2.80	2.36	7.28	2.09	8.46	6.50	3.54	2.95	19.29	15.75	5.12	33.3	
6	32	25	16	3.54	2.80	3.98	3.15	2.64	7.28	2.36	9.45	7.28	3.94	3.35	20.67	16.73	5.12	47	
8	40	32	20	3.94	3.15	4.45	3.54	2.95	7.95	2.64	10.55	8.27	4.41	3.74	22.91	18.50	5.71	66.1	
10	50	40	25	4.41	3.54	5.00	3.94	3.35	10.59	2.95	11.26	8.70	4.92	4.17	26.77	21.85	6.30	92.6	
12	63	50	32	4.92	3.94	5.63	4.41	3.74	11.18	3.35	12.44	9.92	5.51	4.65	29.13	23.62	7.09	129	
16	80	63	40	5.51	4.41	6.30	4.92	4.17	11.93	3.74	14.06	11.02	6.30	5.20	32.28	25.98	7.87	179.9	
20	100	80	50	6.30	4.92	7.09	5.51	4.65	16.34	4.17	15.94	12.99	7.09	5.91	39.37	32.28	8.86	270.1	
25	125	100	63	7.09	5.51	7.95	6.30	5.20	17.52	4.65	17.91	14.17	7.87	6.69	43.31	35.43	10.04	381.6	
32	160	125	80	7.87	6.30	8.86	7.09	5.91	19.29	5.20	20.08	15.75	8.82	7.48	48.19	39.37	11.42	524	
40	200	160	100	8.82	7.09	9.92	7.87	6.69	19.02	5.91	22.32	17.60	9.84	8.35	51.18	41.34	12.60	719.1	
50	250	200	125	9.84	7.87	11.22	8.82	7.48	19.88	6.69	25.00	19.09	11.02	9.29	55.91	44.88	13.98	1002.7	
63	320	250	160	11.02	8.82	12.60	9.84	8.35	23.23	7.48	27.95	21.65	12.40	10.43	63.58	51.18	15.75	1418	
80	400	320	200	12.40	9.84	14.09	11.02	9.29	17.64	8.35	31.57	23.54	13.98	11.81	63.19	49.21	17.72	1675.5	
100	500	400	250	13.98	11.02	15.83	12.40	10.43	20.20	9.29	35.51	27.09	15.75	13.19	71.46	55.71	19.88	2689.6	
125	630	500	320	15.75	12.40	17.72	13.98	11.81	23.62	10.43	40.16	29.53	17.72	14.76	81.50	63.78	22.44	3858.1	
160	800	630	400	17.72	13.98	19.88	15.75	13.19	25.39	11.81	45.08	32.48	19.69	16.73	90.16	70.47	25.20	5467.5	
200	1000	800	500	19.69	15.75	22.24	17.72	14.76	30.43	13.19	50.20	35.43	22.05	18.70	102.68	80.63	28.35	7539.8	
250	1250	1000	630	22.05	17.72	25.00	19.69	16.73	34.45	14.76	56.30	38.58	24.80	20.87	115.55	90.75	31.89	10582.2	

- Hooks shown here are standard models; inquiries for custom versions are welcome.
- Lifting capacity determined according to crane group 1Bm as specified in DIN 15400.



RAMSHORN HOOK

**ACCORDING TO EN 13001-3-5 ANNEX B
[PREVIOUSLY DIN 15402]**

Find more details about the optimized bending radius on pages 10 & 11

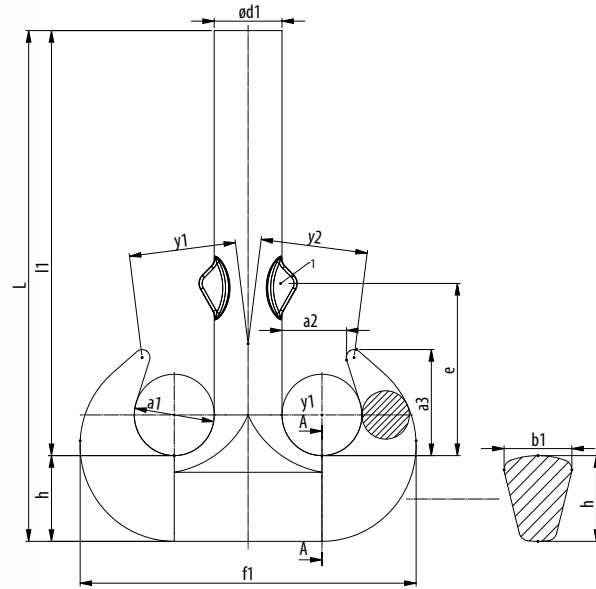

Hook No.	Lifting capacity (UStons)			Dimensions (inch)											Weight (lbs)
	V-Class	T-class	P-class	a1	a2	a3	b1	ød1	e	f1	h	L	l1	y1=y2	
1.6	8.8	6.93	4.4	1.77	1.42	2.32	1.34	1.42	3.94	7.20	1.69	10.43	8.74	2.36	11.7
2.5	13.75	11	6.93	1.97	1.57	2.56	1.57	1.65	4.41	8.19	1.97	11.81	9.84	2.56	15.2
4	22	17.6	11	2.20	1.77	2.87	1.89	1.89	4.88	9.37	2.36	15.35	12.99	3.66	22
5	27.5	22	13.75	2.48	1.97	3.23	2.09	2.09	5.63	10.47	2.64	14.65	12.01	3.66	27.6
6	35.2	27.5	17.6	2.80	2.20	3.62	2.36	2.36	6.30	11.85	2.95	19.88	16.93	3.66	38.6
8	44	35.2	22	3.15	2.48	4.06	2.64	2.64	7.17	13.27	3.35	21.06	17.72	4.11	58
10	55	44	27.5	3.54	2.80	4.57	2.95	2.95	7.56	14.84	3.74	23.03	19.29	4.63	77.2
12	69.3	55	35.2	3.94	3.15	5.12	3.35	3.35	8.27	16.57	4.17	24.25	20.08	5.22	108
16	88	69.3	44	4.41	3.54	5.75	3.74	3.74	9.33	18.54	4.65	28.27	23.62	5.85	132.3
20	110	88	55	4.92	3.94	6.42	4.17	4.17	10.43	20.91	5.20	33.54	28.35	6.52	213.8
25	137.5	110	69.3	5.51	4.41	7.17	4.65	4.65	12.40	23.54	5.91	39.37	33.46	7.28	297.6
32	176	137.5	88	6.30	4.92	8.07	5.20	5.20	13.19	26.46	6.69	40.16	33.46	8.15	425.5
40	220	176	110	7.09	5.51	9.06	5.91	5.91	14.76	29.69	7.48	47.83	40.35	9.17	617.3
50	275	220	137.5	7.87	6.30	10.24	6.69	6.69	16.54	33.15	8.35	51.65	43.31	10.43	745.2
63	352	275	176	8.82	7.09	11.50	7.48	7.48	18.11	37.17	9.29	56.54	47.24	11.69	1188.3
80	440	352	220	9.84	7.87	12.80	8.35	8.35	20.28	41.81	10.43	59.65	49.21	13.03	1675.5
100	550	440	275	11.02	8.82	14.33	9.29	9.29	22.64	46.69	11.81	67.91	56.10	14.57	2425.1
125	693	550	352	12.40	9.84	16.06	10.43	10.43	25.39	52.36	13.19	74.21	61.02	16.32	3287.1
160	880	693	440	13.98	11.02	18.03	11.81	11.81	28.54	59.25	14.76	83.46	68.70	18.35	4662.8
200	1100	880	550	15.75	12.40	20.28	13.19	13.19	31.50	66.34	16.73	95.39	78.66	20.57	6646.9
250	1375	1100	693	17.72	13.98	22.83	14.76	14.76	34.45	74.21	18.70	107.28	88.58	23.13	9409.3

- Hooks shown here are standard models; inquiries for custom versions are welcome.
- Lifting capacity determined according to crane group 18m as specified in DIN 15400.

 **SEE OUR WARNING & SAFETY INFORMATION ON PAGES 136 - 149**



RAMSHORN HOOK FORM B

ACCORDING TO EN 13001-3-5 ANNEX B
(PREVIOUSLY DIN 15402)

Find more details about the optimized bending radius on pages 10 & 11

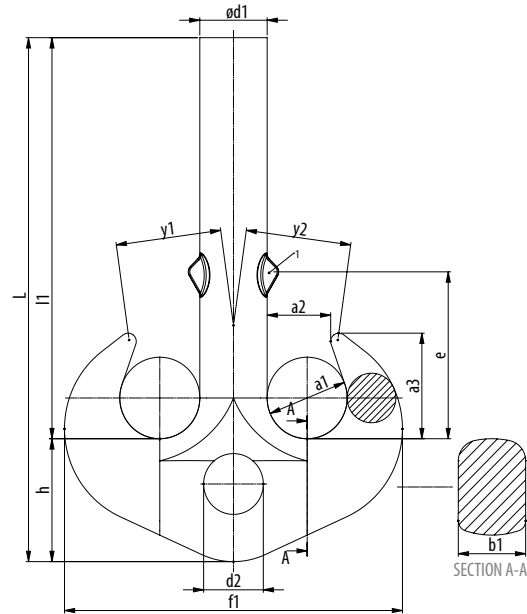

Hook No.	Lifting capacity (UStons)			Dimensions (inch)													Weight (lbs)
	V-Class	T-class	P-class	a1	a2	a3	b1	ød1	d2 (H15)	e	f1	h	L	l1	y1=y2		
8	44	35.2	22	3.15	2.48	4.06	2.64	2.64	2.91	7.17	13.27	4.72	21.06	16.34	4.11	66.1	
10	55	44	27.5	3.54	2.80	4.57	2.95	2.95	2.91	7.56	14.84	5.12	22.83	17.72	4.63	90.4	
12	69.3	55	35.2	3.94	3.15	5.12	3.35	3.35	3.07	8.27	16.57	5.91	25.98	20.08	5.22	125.7	
16	88	69.3	44	4.41	3.54	5.75	3.74	3.74	3.39	9.33	18.54	6.69	29.53	22.83	5.85	180.8	
20	110	88	55	4.92	3.94	6.42	4.17	4.17	3.78	10.43	20.91	7.48	33.07	25.59	6.52	253.5	
25	137.5	110	69.3	5.51	4.41	7.17	4.65	4.65	4.17	12.40	23.54	8.35	36.50	28.15	7.28	352.7	
32	176	137.5	88	6.30	4.92	8.07	5.20	5.20	4.57	13.19	26.46	9.29	40.39	31.10	8.15	504.9	
40	220	176	110	7.09	5.51	9.06	5.91	5.91	5.16	14.76	29.69	10.43	45.28	34.84	9.17	727.5	
50	275	220	137.5	7.87	6.30	10.24	6.69	6.69	5.75	16.54	33.15	11.81	49.80	37.99	10.43	1009.7	
63	352	275	176	8.82	7.09	11.50	7.48	7.48	6.61	18.11	37.17	13.19	56.10	42.91	11.69	1406.5	
80	440	352	220	9.84	7.87	12.80	8.35	8.35	7.40	20.28	41.81	14.76	63.39	48.62	13.03	1966.5	
100	550	440	275	11.02	8.82	14.33	9.29	9.29	8.19	22.64	46.69	16.73	70.87	54.13	14.57	2751.4	
125	693	550	352	12.40	9.84	16.06	10.43	10.43	9.25	25.39	52.36	18.70	79.72	61.02	16.32	3873.5	
160	880	693	440	13.98	11.02	18.03	11.81	11.81	10.24	28.54	59.25	20.87	89.57	68.70	18.35	5511.6	
200	1100	880	550	15.75	12.40	20.28	13.19	13.19	11.10	31.50	66.34	23.62	100.79	77.17	20.57	7848.5	
250	1375	1100	693	17.72	13.98	22.83	14.76	14.76	12.28	34.45	74.21	26.38	113.39	87.01	23.13	11095.9	

- Hooks shown here are standard models; inquiries for custom versions are welcome.
- Lifting capacity determined according to crane group 1Bm as specified in DIN 15400.



SEE OUR WARNING & SAFETY INFORMATION ON PAGES 136 - 149



LATCHES

Single Hook	Ropeblock Standard Safety Latch	Ropeblock Standard Safety Latch incl. locking bracket	Ropeblock Heavy Duty Safety Latch	Dimensions (inch) O
1,6	64.1,6.E	on request	on request	1.57
2,5	64.2,5.E	on request	64.2,5.E.B	1.61
4	64.4.E	on request	64.4.E.B	1.93
5	64.5.E	64.5.E.F	64.5.E.B	2.17
6	64.6.E	64.6.E.F	64.6.E.B	2.32
8	64.8.E	64.8.E.F	64.8.E.B	2.72
10	64.10.E	64.10.E.F	64.10.E.B	2.99
12	64.12.E	64.12.E.F	64.12.E.B	3.31
16	64.16.E	64.16.E.F	64.16.E.B	3.82
20	64.20.E	64.20.E.F	64.20.E.B	4.33
25	64.25.E	64.25.E.F	64.25.E.B	5.20
32	64.32.E	64.32.E.F	64.32.E.B	5.39
40	64.40.E	64.40.E.F	64.40.E.B	6.57
50	64.50.E	64.50.E.F	64.50.E.B	7.40
63	64.63.E	64.63.E.F	64.63.E.B	8.07
80	64.80.E	on request	64.80.E.B	8.98
100	64.100.E	on request	64.100.E.B	11.42
125	64.125.E	on request	on request	290
160	on request	on request	on request	on request
200	on request	on request	on request	on request
250	on request	on request	on request	on request

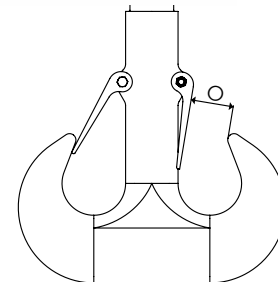

Rams-horn Hook (form b)	Ropeblock Standard Safety Latch	Ropeblock Standard Safety Latch incl. locking bracket	Ropeblock Heavy Duty Safety Latch	Dimensions (inch) O
2,5	64.1,6.E	on request	on request	1.18
4	64.2,5.E	on request	64.2,5.E.B	1.22
5	64.4.E	64.5.D.F	64.4.E.B	1.50
6	64.5.E	64.6.D.F	64.5.E.B	1.89
8	64.6.E	64.8.D.F	64.6.E.B	1.85
10	64.8.E	64.10.D.F	64.8.E.B	2.24
12	64.10.E	64.12.D.F	64.10.E.B	2.36
16	64.12.E	64.16.D.F	64.12.E.B	2.48
20	64.16.E	64.20.D.F	64.16.E.B	2.87
25	64.20.E	64.25.D.F	64.20.E.B	3.43
32	64.25.E	64.32.D.F	64.25.E.B	4.25
40	64.32.E	64.40.D.F	64.32.E.B	4.41
50	64.40.E	64.50.D.F	64.40.E.B	5.12
63	64.50.E	64.63.D.F	64.50.E.B	5.75
80	64.63.E	64.80.D.F	64.63.E.B	6.54
100	64.80.E	64.100.D.F	64.80.E.B	7.48
125	64.100.E	on request	64.100.E.B	8.46
160	64.125.E	on request	on request	9.65
200	on request	on request	on request	on request
250	on request	on request	on request	on request

SEE OUR WARNING AND SAFETY INFORMATION ON PAGE 136



 SEE OUR WARNING & SAFETY INFORMATION ON PAGES 136 - 149

Ropeblock latches are zinc plated and are also available in stainless steel.



SWIVELS

Ropeblock swivels may be used in applications where wire rope twist needs to be released. Designed for different applications like drilling, subsea, lifting, etcetera.

Some of the key features:

- Closed body design
- Low weight design
- High capacity, low friction thrust bearings
- Wide variety of interfacing connections
- Subsea capabilities optional
- Proofloaded and serialized
- Finish depending on specific requirements

**PLEASE CONTACT US
FOR MORE DETAILS**



SPLIT OVERHAUL BALLS

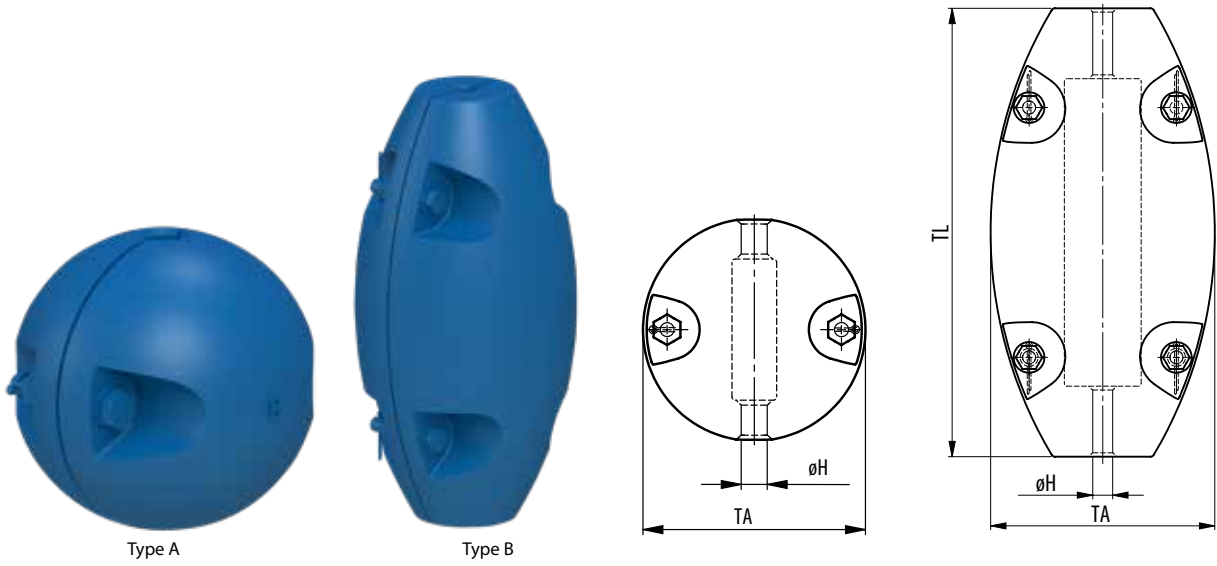

Model No.	Type	Wire ø (inch)	Dimensions (inch)			Weight (lbs)
			øH	TA	TL	
SOBA 5.6	A	¼	0.24	4.33	-	11.0
SOBA 5.12	A	½	0.47	4.33	-	11.0
SOBA 8.16	A	⅝	0.63	5.28	-	17.6
SOBA 10.12	A	½	0.47	5.91	-	22.0
SOBA 15.16	B	⅝	0.63	5.31	8.27	33.1
SOBA 25.16	B	⅝	0.63	5.91	10.24	55.1
SOBA 35.16	B	⅝	0.63	6.69	13.78	77.2
SOBA 50.20	B	1⅜	0.79	7.87	14.17	110.2
SOBA 75.20	B	1⅜	0.79	10.63	14.57	165.3
SOBA 100.28	B	1⅞	1.10	11.02	15.75	220.5

- Weights can be made suitable for larger wire diameters (optional).
- Painted blue (RAL 5017).

 SEE OUR WARNING & SAFETY INFORMATION ON PAGES 136 - 149



TRIANGLE PLATES

NEN 3561 / DIN 82015

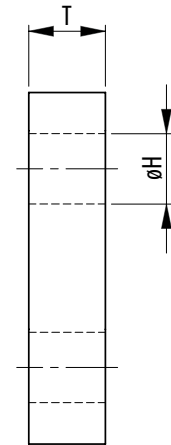
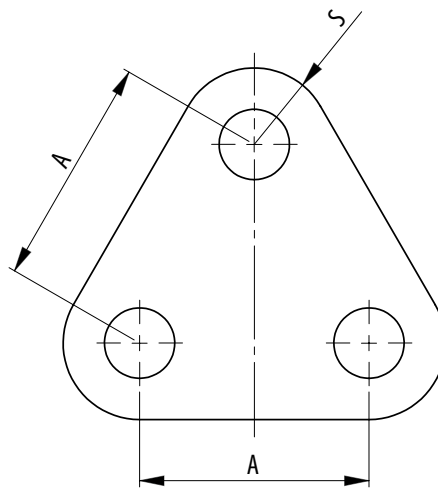

Model No.	WLL (UStons)	MBL (UStons)	Dimensions (inch)				Weight (lbs)
			A	ØH	T	S	
TP 25.23.2	2.2	11	2.95	0.91	0.98	0.98	3.7
TP 30.30.3	3.3	16.5	3.54	1.18	1.18	1.18	6.4
TP 35.39.5	5.5	27.6	4.53	1.54	1.38	1.57	13
TP 45.48.8	8.8	44.1	5.51	1.89	1.77	1.97	24
TP 50.52.10	11	55.1	5.71	2.05	1.97	2.17	31

Minimum Ultimate Strength = 5 x WLL

- Other sizes possible.
- Painted blue (RAL 5017).
- Material certificate according EN 10204 3.1 included.

**SEE OUR WARNING
& SAFETY INFORMATION
ON PAGES 136 - 149**



TRIANGLE PLATES; HIGH TENSILE PLATES

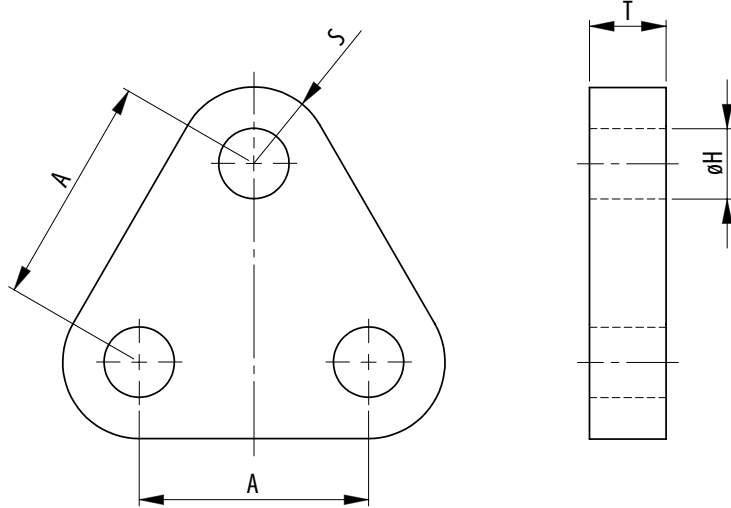

Model No.	WLL (UStons)	MBL (UStons)	Dimensions (inch)				Weight (lbs)
			A	øH	T	S	
TP 40.35.9,5	10.5	52.4	3.94	1.38	1.57	1.38	11
TP 40.40.12	13.2	66.1	4.33	1.57	1.57	1.57	14
TP 45.42.13,5	14.9	74.4	4.72	1.65	1.77	1.67	18
TP 45.45.17	18.7	93.7	5.12	1.77	1.77	1.97	24
TP 50.55.25	27.6	137.8	5.51	2.17	1.97	2.56	37
TP 60.60.35	38.6	192.9	5.91	2.36	2.36	2.76	51
TP 80.75.55	60	303.1	7.09	2.95	3.15	3.35	97
TP 90.90.85	93	468.5	8.66	3.54	3.54	4.33	175
TP 110.105.120	132	661.4	9.45	4.13	4.33	5.12	280
TP 130.115.150	165	826.7	10.24	4.53	5.12	5.31	360
TP 140.115.175	192	964.5	11.42	4.53	5.51	5.71	480
TP 150.140.200	220	1102.3	14.96	5.51	5.91	6.30	725
TP 170.150.250	275	1377.9	17.72	5.91	6.69	6.89	1080
TP 170.160.300	330	1653.5	15.75	6.30	6.69	9.06	1325
TP 200.180.400	440	2204.6	18.90	7.09	7.87	10.24	2125
TP 200.200.500	550	2755.8	19.69	7.87	7.87	12.20	2720
TP 250.220.600	660	3306.9	21.65	8.66	9.84	12.20	3615
TP 250.230.700	770	3858.1	22.83	9.06	9.84	13.39	4250
TP 250.235.800	880	4409.2	23.23	9.25	9.84	14.96	4965
TP 280.245.900	990	4960.4	24.41	9.65	11.02	16.14	6415
TP 300.255.1000	1100	5511.6	25.59	10.04	11.81	16.93	7570
TP 320.285.1250	1375	6889.4	28.74	11.22	12.60	19.29	10400
TP 320.305.1500	1650	8267.3	30.71	12.01	12.60	22.44	13370

Minimum Ultimate Strength = 5 x WLL

- Other sizes possible.
- Painted blue (RAL 5017).
- Material certificate according EN 10204 3.1 included.

 SEE OUR WARNING & SAFETY INFORMATION ON PAGES 136 - 148



PAD EYES TYPE S

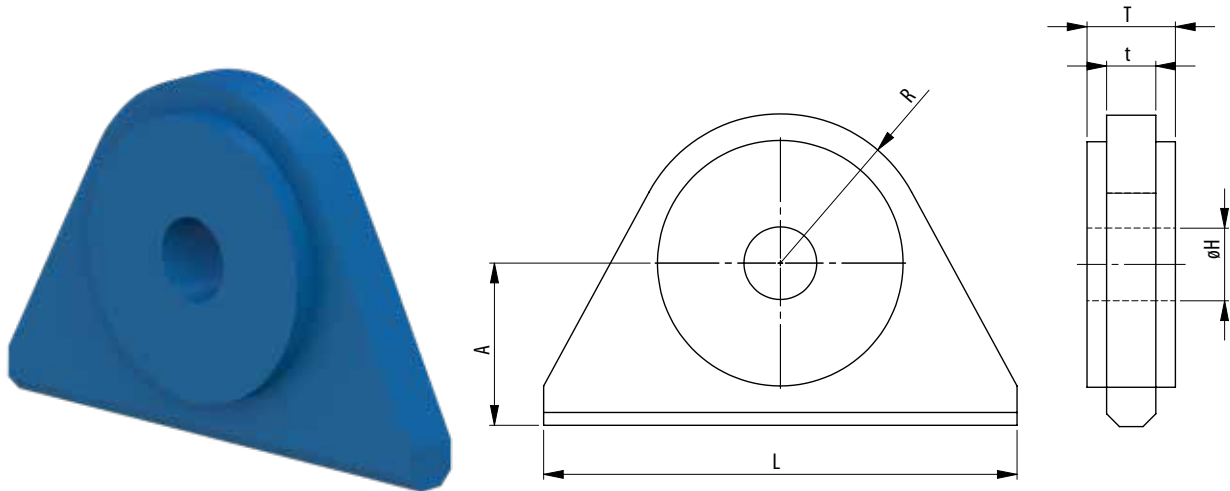

Model No.	Shackle size	WLL (UStons)	Dimensions (inch)						Weight (lbs)
			L	A	øH	R	t	T	
PE 14.11,5.1	3/8	1.1	2.99	1.26	0.45	1.02	0.55	0.55	0.7
PE 15.13,5.1,5	7/16	1.7	3.54	1.26	0.53	1.26	0.59	0.59	1.1
PE 18.17.2	1/2	2.2	3.94	1.50	0.67	1.38	0.71	0.71	1.5
PE 22.20.3,25	5/8	3.6	4.53	1.77	0.79	1.50	0.87	0.87	3.3
PE 25.23.4,75	3/4	5.2	5.51	2.01	0.91	1.77	0.98	0.98	4.4
PE 30.26.6,5	7/8	7.2	5.91	2.24	1.02	2.01	1.18	1.18	6.6
PE 35.29,5,8,5	1	9.4	7.09	2.52	1.16	2.52	1.38	1.38	11
PE 40.33,5,9,5	1 1/8	10.5	7.99	2.99	1.32	2.99	1.57	1.57	17
PE 45.37.12	1 1/4	13.2	8.50	3.27	1.46	3.27	1.77	1.77	22
PE 50.40.13,5	1 3/8	14.9	8.98	3.50	1.57	3.50	1.18	1.97	22
PE 50.44.17	1 1/2	18.7	11.02	5.51	1.73	4.02	1.57	1.97	40
PE 60.53.25	1 3/4	27.6	12.01	5.51	2.09	4.76	1.57	2.36	51
PE 70.60.35	2	38.6	14.02	6.02	2.36	5.24	1.97	2.76	77
PE 90.74.55	2 1/2	60.6	18.98	6.50	2.91	5.98	1.97	3.54	121
PE 110.87.85	3	93.7	22.01	7.99	3.43	7.01	2.36	4.33	198
PE 120.100.120	3 1/2	132.3	27.99	10.00	3.94	9.02	2.76	4.72	375
PE 150.114.150	4	165.3	32.01	11.02	4.49	10.00	3.15	5.91	551

Minimum Ultimate Strength = 6 x WLL

- Pad eyes will be supplied including material certificates (S355J2G3, EN 10204 3.1)
- $T \geq 75\%$ of inside width of shackle.
- $H \leq 106\%$ of diameter of pin.
- Well primer applied



UNDERSTANDING MARKETS

Smart Engineering is about more than developing and optimising products. It's also about knowing where and how they will be implemented. It's only by understanding industry specific circumstances, needs and priorities that you can come up with the answers your customers actually require. This market oriented philosophy has always been the driving force behind everything we do at Ropeblock. As a result, we are very much at home in the market segments most relevant to our business.





Cargo handling / maritime



Rigging



Infrastructure



Heavy lifting



Dredging



Industry



Offshore



CONSTRUCTION

Leading crane OEMs with a focus on the construction industry as well as end users in construction prefer Ropeblock for proven quality blocks, sheaves, sockets and other crane components. Our portfolio covers the entire spectrum of applications, from rough terrain cranes, mobile cranes and crawler cranes to tower cranes in all shapes and sizes. All products are Smart Engineered for safety, quality, and efficiency.

Besides standard components instantly available from stock we can supply customer specific engineered solutions. By largely basing these solutions on standard components, we minimize engineering costs. With advanced supply chain services and top-notch manufacturing processes we ensure forecast based, just-in-time delivery and constant quality.



For OEMs of cranes used on cargo vessels, in cargo handling equipment and at bulk & container terminals, Ropeblock is the supplier of choice when it comes to reliable crane hardware. Our portfolio features premium quality sheaves (larger sizes included), hoisting blocks, turnbuckles, sockets and other components.

All Ropeblock products are engineered in accordance with relevant design rules such as those stipulated by DNV. We can provide any applicable certification, ranging from basic ILO-3 certificates to third-party design approvals and witnessed proof loading certificates. Most standard components are available from stock. Should standard products fail to match your exact specifications, our Smart Engineers will waste no time making the necessary adaptations and providing the required solutions.

CARGO HANDLING/ MARITIME





OFFSHORE

Knuckle boom and mast cranes and other systems used for subsea operations. Active heave compensations, pipe-laying systems and heavy lift cranes. Riser and mooring line pull-in systems. Man-riding cranes and drilling rigs. All of the above are offshore applications in which Ropeblock sheaves, swivels, sockets, blocks and other components often play key parts.

As working conditions in the offshore industry keep getting more taxing in terms of cold, depth, and load, system fatigue is a primary concern. This is why manufacturers as well as end users worldwide rely on the proven quality of Ropeblock components. Whether standard or customized, our products are Smart Engineered to meet the strictest rules and regulations rules (such as ABS, DNV, API). No compromises are made, especially where safety is at stake.



In the dredging industry, increasingly large and extreme equipment requires increasing investments. Add the fact that dredging often takes place in harsh environments devoid of infrastructure, and reliable performance becomes an even more dire necessity. That's why dredging companies have been embracing Ropeblock as a trusted partner for decades. Sharing the same hands-on mentality and proud to be part of this typically Dutch industry, we combine Ropeblock experience and customer input to create safe solutions with maximum uptime and minimum maintenance.

Ropeblock offers Smart Engineered products such as wire rope sheaves, sockets, hoisting and anchor boom blocks and turnbuckles that are ideally suited for use in on-board systems. Applications may include heave compensations and gantry cranes as well as hoisting systems for spuds, anchors, cutter ladders and suction tubes. Our solutions are complemented by superb spares availability and meticulous after-sales services.

DREDGING





INDUSTRY

Ropeblock is the market leading designer and manufacturer of overhead cranes for industrial purposes. Our motorized hoisting blocks, sheaves and hooks are applied to great effect in specific hoisting equipment used worldwide in, e.g., steel mills, forging plants, power plants, ship yards and the automotive and aviation industries. In these and many other industrial environments Ropeblock equals optimum performance and reliability, hence maximum uptime.

Practical applications include heavy duty workshop cranes, maintenance cranes for use in hard-to-reach places, emergency cranes that will keep working in even the most extreme conditions (including nuclear), and onshore cranes. Standing out by compact design, Ropeblock's overhead crane blocks for industrial applications are fitted with double sealed roller bearings for maximum efficiency. Cast sheaves with graphite lubricated grooves ensure smooth operation and wire rope longevity. The extensive Ropeblock portfolio includes customer specific connections, hooks, eyes, etcetera.



Manufacturers as well as end users of heavy lifting equipment worldwide turn to Ropeblock for components designed to take on extreme loads (up to 5.000 metric tonnes) and heavy haulage. We can supply hardware for - and co-engineer - main, auxiliary, jib and boom hoisting systems, derricks, luffing systems and the like.

Top sheaves and other specific Ropeblock components are used in many heavy lifting applications, such as shipyard gantry cranes and systems for the offshore, wind energy and decommissioning industries. Besides standard components we have ample knowledge and experience when it comes to meeting unusual customer requests by Smart Engineering dedicated one-offs.

HEAVY LIFTING



All over the world, Ropeblock sockets, sheaves, turnbuckles and other components are used in bridges, locks, funiculars, slipways and other civil engineering works with moving parts. Our excellent reputation in this industry comes as no surprise, as, rooted in the Netherlands, we have extensive knowledge of (water) infrastructures. We like to join forces with governments, civil engineers and contractors to create Smart Engineered solutions that ensure both safety and efficiency

In infrastructure as in other industries, Ropeblock products have amply proven to be low-maintenance and safe. In addition, we often include practical features such as easy personnel access. Another essential Ropeblock benefit is reliability, which is all the more important in view of the high cost usually associated with replacements.

INFRA- STRUCTURE





RIGGING

Manufacturers as well as end users of heavy lifting equipment worldwide turn to Ropeblock for components designed to take on extreme loads (up to 5,000 metric tonnes) and heavy haulage. We can supply hardware for - and co-engineer - main, auxiliary, jib and boom hoisting systems, derricks, luffing systems and the like.

Top sheaves and other specific Ropeblock components are used in many heavy lifting applications, such as shipyard gantry cranes and systems for the offshore, wind energy and decommissioning industries. Besides standard components we have ample knowledge and experience when it comes to meeting unusual customer requests by Smart Engineering dedicated one-offs.



WARNING & SAFETY INFORMATION

2023

**GENERAL WARNING, USE, INSPECTION,
MAINTENANCE AND SAFETY INFORMATION FOR
LIFTING AND RIGGING COMPONENTS.**

**WARNING: THIS DOCUMENT CONTAINS IMPORTANT
INFORMATION FOR THE SAFE AND PROPER INSTALLATION
AND USE OF YOUR ROPEBLOCK COMPONENTS.**

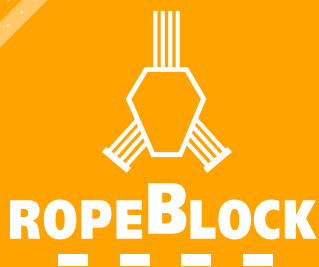

CONTENTS



GENERAL	138
Disclaimer	
Manufacturer contact details	
Contract information	
DEFINITIONS	138
HEALTH AND SAFETY WARNING	139
LIMITATIONS OF USE	140
General	
Design	
Service life	
Material	
WARNINGS AND INFORMATION ON USE	141
Transport	
Installation and reeving	
Operation	
Attaching the load	
Tugging	
Sockets	
Turnbuckles	
Rigging accessories	
CERTIFICATION	148
General	
INSPECTION AND MAINTENANCE	148
Spare parts list	





THIS W&S DOCUMENT PROVIDES IMPORTANT INFORMATION CONCERNING THE TRANSPORT, INSTALLATION, USE, INSPECTION, MAINTENANCE AND SAFE USE OF YOUR ROPEBLOCK PRODUCT.

BE SURE TO CONSULT THE MOST RECENT VERSION OF OUR W&S INFORMATION. THIS IS REPLACED EVERY CALENDAR YEAR.

GENERAL

This information is restricted to components used in lifting, rigging, tensioning or lashing intended to be used in lifting-systems or (quasi) static applications. Components typically comprise a head fitting (hook, stud-eye, clevis) and possibly sheaves and are used for lifting, lowering or pulling by applying tension to a wire rope or rope. Or comprise a product helping to connect the wire rope or other components to a structure, other components, or the wire rope itself. Possibly they are then used for lifting, lowering or pulling by applying tension to a wire rope or rope and as such holding and transferring the load. Please examine your Ropeblock product, carefully read and understand the information presented and apply this information in practice. If you do not fully understand the information, **DO NOT PUT YOUR PRODUCT INTO SERVICE**. Please call your sales representative or Ropeblock B.V. directly.

DISCLAIMER

Your Ropeblock product is by default considered a tool or essential part of the intended application and therefore defined by the application or system designer or application owner. In accordance with Machine Directive 2006/42/EC, it is therefore supplied as standard without EC declaration. Where applicable, the product will become part of a CE-marked assembly. The product must then not be put into service until the full assembly has been declared to conform to the provisions of 2006/42/EC. Where the product is considered a lifting accessory, requiring an individual conformity declaration (IIA) or declaration of incorporation (IIB), it should be mentioned in the contract.

The party installing Ropeblock products shall be competent and qualified in the design, construction or maintenance of the relevant application and have the knowledge of the relevant regulations and standards concerning the application/equipment required for proper installation, or be

declared competent by their employer.

The party using Ropeblock products shall be competent and qualified in the operation of the relevant application and have the knowledge of the relevant regulations and standards concerning the application/equipment required for proper operation, or be declared competent by their employer.

Ropeblock is not responsible for any misuse of the products or misinterpretation of this document. Printing and typing errors reserved.

MANUFACTURER CONTACT DETAILS

Ropeblock B.V.	Ropeblock B.V.
PO Box 391	Kampenstraat 1
7570 AJ Oldenzaal	7575 ER Oldenzaal
The Netherlands	The Netherlands
Phone: +31 88 532 32 00	
Email: sales@ropeblock.com	

CONTRACT INFORMATION

Order confirmation is subject to Ropeblock's General Terms and Conditions of Sale and Delivery. These conditions are filed with the Chamber of Commerce under number 060.78.445. Acceptance of our products implies acceptance of the Terms and Conditions in the contract.

DEFINITIONS

SAFE WORKING LOAD (SWL)

The maximum load on the head fitting, as determined by a **competent person**, which an item of Lifting Equipment may raise, lower or suspend **under particular (operational/dynamic) service conditions**.

ALLOWABLE LINE PULL (ALP)

The operational maximum line pull, as determined by a **competent person**, which an item of Lifting Equipment can be subjected to. For a single sheave block, this could also be referred to as SWL (as such, then not on the head fitting).

WORKING LOAD LIMIT (WLL)

The maximum load on the head fitting, as determined by the **manufacturer**, which an item of Lifting Equipment is designed to raise, lower or suspend **under ideal (static) service conditions** with a given safety factor calculated against the MBL.



MINIMUM BREAKING LOAD (MBL)

The load, checked by the **manufacturer** against the minimum theoretical failure strength of the material, at which an item of Lifting Equipment is designed to fail or break. (Or determined empirically in a laboratory breaking load test.) Also referred to as Minimum Breaking Force (MBF).

FACTOR OF SAFETY (FOS)

Factor determined as the ratio between MBL and WLL. Also referred to as the Safety Factor (SF) or Design (Safety) Factor (D(S)F).*

DESIGN DYNAMIC FACTOR (DDF)

The factor specified by the designer of the lifting appliance (e.g. crane). DDF is not the same as DAF, which is defined separately and applicable to a specific operation. $DDF = \text{Design load} / \text{SWL}$.

DESIGN LOAD

Load used for the purposes of design, derived by combining relevant characteristic load(s) (both static and dynamic) with appropriate load factor(s). The design load represents all foreseeable loads and combinations thereof (including all directions) that the lifting appliance will be subject to. Design load shall not be confused with SWL.

PROOF LOAD (PL)

The predetermined test load, greater than the SWL or WLL to which an item of lifting equipment is subjected before acceptance for use.

DESIGN TEMPERATURE

Reference temperature, specified by the designer of the lifting appliance, used as a criterion for the selection of material grades and properties.

MINIMUM OPERATING TEMPERATURE

Lowest temperature, determined by a **competent person**, the item of Lifting Equipment can be operated at without compromising safety.

COMPETENT PERSON

A **competent person** as defined in ISO 9927-1. To determine 'fit-for-use' the level 'Expert Engineer'** is required. Alternatively, a qualified person nominated as such by their employer.

*Note:

The Factor of Safety is the actual MBL/WLL ratio the item itself has. The Design Factor is the MBL/WLL ratio required

for the job the item is engineered to do. The FoS shall therefore be $\geq DF$ and is in most cases the same.

**Note:

An expert engineer is an engineer with experience in the design, construction or maintenance of cranes, sufficient knowledge of the relevant regulations and standards and the equipment necessary for carrying out the inspection. Furthermore, an expert engineer is an engineer who is in a position to judge the safe condition of the crane and to decide which measures shall be taken in order to ensure continued safe operation.

Particular service conditions are defined in combination with the applicable design standards or rules.

With regard to WLL, the client shall act as the competent person to establish fit-for-use under the given particular service conditions against the factor of safety of the item of lifting equipment.

With regard to MBL, the client shall act as the competent person to establish the SWL in conjunction with the given particular service conditions.

HEALTH AND SAFETY WARNING

The party installing Ropeblock products shall be competent in the design, construction or maintenance of the relevant application and have the knowledge of the relevant regulations and standards concerning the application/equipment required for proper installation, or be declared competent by their employer.

The party using Ropeblock products shall be competent in the operation of the relevant application and have the knowledge of the relevant regulations and standards concerning the application/equipment required for proper operation, or be declared competent by their employer.

NEVER USE THE PRODUCTS IF THE CONDITIONS STATED IN THIS DOCUMENT ARE NOT FULFILLED OR IF YOU DO NOT UNDERSTAND THE INFORMATION PRESENTED.

During transportation and handling, a crushing, shearing or dropping hazard exists.

Care shall be taken when installing, working with or repairing lifting or rigging equipment. If installed or



used incorrectly or if a repair is executed incorrectly, loss of stability, falling objects, insufficient mechanical strength or failure of parts could occur and inflict injury or death.

Where your Ropeblock product has swiveling and moving parts, there are potential crushing, shearing or entanglement hazards.

When the product is in use do not put hands:

1. Between sheaves, side plates, guards, wire rope or other moving parts.
2. In the area of becket, hook, hook nut or cross head.

Workers must be made alert and wear proper safety gear at all times. Take great care to avoid clothing becoming trapped or snagged. Pay attention to sharp edges.

Repairs shall be carried out by competent and trained personnel only. Power shall be switched off and stored energy eliminated, before repair activities are carried out. Work shall only take place with the product on a firm surface with the product secured. Always follow local rules and regulations.

LIMITATIONS OF USE

GENERAL

NEVER STAND UNDER THE LOAD.

The Safe Working Load (SWL), Allowable Line Pull (ALP) and Working Load Limit (WLL) shall never be exceeded.

Unless otherwise stated, only fully reeved crane blocks may be loaded up to the rated SWL or WLL. For partial reeving, the load shall always be symmetrically distributed to eliminate tilt, fleet angles and consequent side loading. Reeving shall be carried out by competent personnel only.

Always understand the weight you are lifting and the SWL or WLL of your system and components. The SWL or WLL shall exceed the weight of the intended load you plan to lift, including its rigging.

Swivels and overhaul balls may be loaded up to the rated SWL or WLL and should only be used with rotation-resistant wire ropes. If in doubt, contact your wire rope sales representative for further guidance.

Capacity ratings apply to new products or products

considered to be in an 'as new' condition by a competent and qualified person. Capacity may be affected by wear, misuse, corrosion, impact deformation or modification.

Hook blocks, overhaul balls and swivels shall be used only in vertical lift as they are only designed for this purpose. Side loading may create unacceptable stresses in the component.

Swivels may be used in any orientation when specifically designed for this.

Rigging blocks shall be used in accordance with design specifications and are generally intended for tension and pulling. Blocks shall not be used for towing unless specifically designed and marked for that purpose.

Horizontal and vertical lead sheaves shall be used as indicated in the product description or drawings.

Side loading is prohibited as it may create unacceptable stresses in the component. Shock or side loading shall not be applied unless the product is designed for this purpose.

Skew loading shall be kept to a minimum for undetermined loads. The center of gravity of the load shall be aligned with the hook shank centerline. (See the section on lashing of the load.) The load shall always be placed in the seat or bowl of the hook or eye. **NEVER AT THE POINT.** The latch shall never be allowed to carry the load.

DESIGN

Your Ropeblock product was designed in accordance with the standards and design rules as stated in the contract and/or drawings and/or with knowledge of industry standards (in part or whole) where applicable and can as such be considered state-of-the-art.

Design parameters such as SWL or WLL, load group or factor of safety, wire rope size, weight and design or operating temperature must be visible on the product tag plate, or be engraved, or be traceable back from the certificate or contract by its serial number. **DO NOT USE YOUR PRODUCT WITHOUT THIS INFORMATION.**

WLL equipment is by default designed with a FoS of 4:1 unless specified otherwise on the tag plate.

Appropriate overhaul weight, if required, may vary



due to crane design, geometrical design, materials, wire rope selection, and environmental circumstances such as temperature.

Sheave bearings should have separate lubrication channels if your Ropeblock product is to be used in a maritime, offshore, or otherwise significantly corrosion aggressive environment.

SERVICE LIFE

Generically designed products (WLL products) should meet their normal service life when used in their intended application. Check with your sales representative for information.

Specifically designed products (SWL products) should meet their intended service life according to the prescribed design standard or 3rd party rules from the application or system designer. The service life of Ropeblock products will significantly depend on the actual intensity of use, or possible misuse. Monitoring for wear and reduced capacity is essential for continued safe operation (see the section on inspection and maintenance).

Special consideration is required for vibration work or pile driving work as this may significantly increase load cycles and promote early fatigue and/or even premature failure in relevant components depending WLL of the equipment and the actual workload. Vibrational impact or resonance of Round Overhaul Balls beyond levels in normal lift crane applications shall be eliminated. Vibration work and pile driving work are not considered normal lift crane applications. Optional features like detachable,- or interchangeable cheek weights shall be removed prior to operation with vibration equipment or pile driving equipment unless specifically designed and confirmed by Ropeblock B.V. in writing to work with it.

MATERIAL

For generically designed products (WLL products), the operating temperature limits are -40°C / $+80^{\circ}\text{C}$ with steel or iron sheaves*. The structural materials in these blocks provide suitable ductility for use at the stated temperatures with 100% capacity and at normal speed of operation.

* Note: -30°C / $+50^{\circ}\text{C}$ applies for equipment with nylon (Pa6G) sheaves.

For use in applications or environments other than

those originally intended, please contact your sales representative or Ropeblock B.V.

Products specifically designed in accordance with prescribed design standards or 3rd party rules (SWL products) will possess adequate ductility in their materials as specified at the reference design temperature in those standards or rules.

Components from grade 8 upwards must not be used in highly alkaline ($>\text{pH}10$) or acidic conditions ($<\text{pH}6$). Comprehensive and regular examination shall be carried out when they are used in severe or corrosion inducing environments to prevent hydrogen embrittlement and consequent severe loss of ductility and/or premature failure.

All Ropeblock products are asbestos-free.

If in doubt, please contact your Ropeblock sales representative for the relevant drawings and information.

WARNINGS AND INFORMATION ON USE

TRANSPORT

The products shall be handled with care. Depending on the surface it is placed on, the product may tilt and tip over, roll or slide. A potential crushing hazard exists.

Lifting or lashing points shall be used for their intended purpose only. **NEVER USE IN OR WITH THE APPLICATION.** Use other lifting equipment to handle the product if required.

INSTALLATION AND REEVING

Always verify that the product is in its proper and intended condition suitable for your application. Reeving shall be performed on a firm surface to prevent the block from tipping over.

Only fully-reeved crane blocks may be loaded up to the rated SWL or WLL. For partial reeving, the loads shall always be symmetrically distributed to eliminate tilt, fleet angles and consequent side loading. Reeving shall be carried out by competent personnel only.

Typical efficiency losses for sheaves with roller bearings and wire rope are 2% per wire rope bend. Actual efficiency losses may vary due to crane design, load, block weight, geometrical design, material, wire rope selection and environmental conditions.



Admissible fleet angles shall be monitored according to the relevant standards. They are typically 4° for non-rotation resistant wire rope and 2° for rotation resistant wire rope.

The wire rope selected for your application shall be suitable for the Ropeblock product and the dimensional factors in your system. Reeving shall be in accordance with the crane or system designer's diagram.

The sheave groove geometry shall not hinder proper function with the prescribed wire rope. According to EN 13135, for a new build the radius should be within half the nominal wire rope size + min. 5% / + max. 12%. Check your actual sheave radius with the nominal wire rope size before installation.

Avoid wire rope from becoming damaged during installation. The wire rope shall be seated in the groove of the sheave before closing the reeve guides. Make sure all reeve guards are closed and secured.

Poor wire rope installation may affect the proper functioning of your Ropeblock product resulting in cabling (rotation of the block until the wire ropes are entangled).

Overhaul balls and swivels should only be used with rotation-resistant wire ropes. If in doubt, contact your wire rope sales representative for further guidance.

Ensure your end-of-line switch is functioning properly or other means have been implemented to prevent two-blocking. The lower block shall not come into contact with the upper block or sheave arrangement of the crane unless a receiver on the crane, the crane and the block itself were designed for this purpose.

Make sure all optional features (additional weights, sheaves, pins, etc.) are properly secured. If in doubt, contact your sales representative or Ropeblock.

Lifting points on optional features are designed for ONE unit only. NEVER PICK STACKED UNITS WITH ONE LIFTING POINT. Do not add components or mass to the product unless it has been designed by Ropeblock and intended for this purpose.

OPERATION

Always follow the prescribed inspection protocols and ensure that the product condition complies with the requirements for the job and the product has been properly maintained.

The Safe Working Load (SWL), Allowable Line Pull (ALP) or Working Load Limit (WLL) shall never be exceeded.

To ensure structural integrity of the product, only fully closed and properly fitted products may be put into operation in your system. All locks, pins and retainers shall be properly assembled and/or tightened prior to any operation to eliminate potential falling objects or loads that may inflict injury or death.

Always understand the weight you are lifting and the SWL or WLL of your system and components. The SWL or WLL shall exceed the weight of the intended load you plan to lift, including its rigging. Crane blocks shall be used in vertical lift. Shock or side loading shall not be applied. Prevent your product from coming into contact with any structure or object during a lift since this could result in a loss of load.

Optional features like detachable,- or interchangeable cheek weights shall be removed prior to operation with vibration equipment.

Skew loading the hook shall be kept to a minimum for undetermined loads. The center of gravity of the load shall be aligned with the hook shank centerline.

Ensure that the hook rotates freely under load, and that your reeving is able to generate the required counter momentum for the thrust bearing to prevent cabling.

Do not rotate hooks, eyes or other suspensions with only a washer (i.e. without a bearing) under load. Ensure you are following the applicable local and national regulations.

ATTACHING THE LOAD

The lashing or rigging arrangement of the load shall be limited to a 90° included angle between two slings and the maximum single sling angle (from vertical) shall be less than 45° for single hooks and less than 60° for ramshorn hooks.

Forces in slings shall be limited to the following:



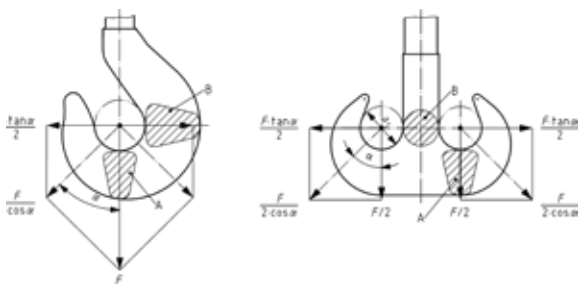

Skew loading shall be avoided by adjusting the rigging arrangement below the hook to allow the center of gravity of the load to line up with the centerline of the hook shank. The hook shall receive symmetrical vertical loads to minimize additional stress due to the bending of the hook shank.

If there is foreseeable misuse of skew loading, this shall be limited to the maximum permitted fleet angles of the wire rope in your system. The skew load factor shall at all times be less than 1.25. (50/40 load distribution in a ramshorn hook.) Skew loading may induce poor hook swivelling performance.

When considered applicable to your application, detailed lashing limits analysis should be undertaken in accordance with EN 13001-3.5 and be communicated to the operators.

The lashing or rigging arrangement shall at all times be in accordance with acceptable practice and be appropriate to the application and intended lift.

The wire rope slings shall be selected to be appropriate to the hook and its seat-bending radius. This D/d ratio shall be in accordance with acceptable practice. Depending on the wire rope, a $D/d \geq 1$ typically applies for 6x19 or 6x37 Flemish eye slings (loop) and greater than this for basket hitches.

Check the D/d ratio and the effect on sling capacity with your wire rope or sling manufacturer.

Alternatively, use master links or other hardware to ensure your slings maintain the required strength for the lift. See e.g. ISO 8792 for further guidance.

We recommend using hardware that matches the shape of the hook/counterpart to prevent damage to the hook seat or bowl/counterpart.

The use of fibre slings should be verified with the manufacturer of the sling.

Latches shall be closed during the lift. NEVER LOAD A LATCH.

TUGGING

If tugging is a mode of operation, this shall be such that the rigging, and consequently the Ropeblock product, is free from significant forces perpendicular to the vertical hoisting forces from the load.

Perpendicular forces are a side load and create a bending moment. Unless specifically indicated, your product is not designed for this. Tugging lines are intended only to hold the product in position.

SOCKETS

GENERAL

Safety measures should be taken into account when using our sockets. Carefully follow all installation instructions. Important information can be found below.

Ropeblock sockets provide adequate ductility and should be considered fit for purpose until minimum operating temperatures of -40°C in general service application. Check your application specific criteria with the set design temperature against the specifications set forth in the applicable design standards or rules. Ropeblock sockets meet or exceed 42J/ -20°C , alt. 34J/ -40°C Charpy "V" impact values.

Excluding limitations set forth by the wire rope and/or resin or spelter material as described in the EN and ISO standards (typ. 80°C for fibre core ropes and 110°C for resin), sockets will be affected by higher temperatures too, but continue to serve with below approximate limited work load capacity rating at these elevated temperatures.

110°C with 100% capacity rating
150°C with 92% capacity rating
200°C with 83% capacity rating
250°C with 75% capacity rating
300°C with 67% capacity rating

Your application requires compensation for this. For intermittent use at elevated temperatures the temperature the socket body will reach should be determined. Use above 300°C is not recommended, contact Ropeblock for further guidance.

Dimensional tolerances depend on the manufacturing techniques applied and are different between machined components (pins) and cast components (socket bodies and wedges). Also surface finish e.g. hot dip galvanizing or even paint may add to the overall thickness and fork distance.



Please contact Ropeblock for further guidance and a detailed dimensional tolerance sheet.

All spelter sockets and wedge sockets receive the vigorous Ropeblock Non Destructive Testing (NDT) regime. This working program is covering both surface inspections (MT and visual) as well as volumetric inspections (UT). Volumetric RT inspections can be done on request. Certificates are available when so ordered.

Socket(pin)s may be used as an orientating hinge-point. To prevent excessive wear and additional rope bending they should not be used as a friction hinge point under load. Further design evaluation and creating a proper functional hinge point is advised. Check for potential pin rolling with axial movement that may develop depending operation.

- ❑ **ALWAYS CARRY OUT A VISUAL INSPECTION BEFORE USING A SOCKET AND PIN.**
- ❑ **NEVER USE A PART SHOWING CRACKS OR DAMAGES.**
- ❑ **DO NOT SIDE-LOAD A SOCKET.**
- ❑ **REPAIRS ARE NOT ALLOWED; FOR CONSULTATION CONTACT ROPEBLOCK.**
- ❑ **NEVER SHOCK-LOAD A SOCKET.**

PROOF TESTING INDIVIDUAL SOCKETS

Sockets can be individually proof tested on request. The default proof load value is 40% of the catalogue MBL for spelter sockets and 30% for wedge sockets. Higher values until 50% will require special consideration and is strongly advised against.

PROOF TESTING SOCKETED ASSEMBLIES

Per EN 13411-4:2011 type testing may be required. Please see the standard and annex C and F for further guidance. (Alternatively ISO 17558:2006.) Depending the application, end-user requirement and / or local regulations, socketed assemblies may require to be proof tested individually with a proof load relative to the Work Load Limit or Safe Working Load assigned to the socketed assembly.

SPELTER SOCKETS

- Proper spelter socket terminations have an efficiency equal to the breaking load of the wire. This can be limited by the minimum breaking load of the socket (MBL), as mentioned in the tables.
- For further performance specifications, see our type approvals.
- Please read the instructions of the resin manufacturer carefully before use. Incorrect use of

the resin or spelter material can result in an unsafe termination. Look for the expiration date of the resin. More information can also be obtained from your wire rope supplier.

- Always remove any dirt and grease from the wire rope broom and socket basket.
- Ensure that the broomed wires are evenly spaced in the basket and that the wire and basket are aligned with each other.
- When using white metal or zinc, the socket may be preheated up-to 350°C (660°F).
- Make sure the base of the socket is properly sealed. This to prevent resin leakage, which may cause voids.
- It is recommended to pour on one side as this will help eliminate air bubbles being formed.
- Check for proper penetration of the resin to the bottom. Recommendation to use a 1mm probe wire between the strands to validate resin penetration if possible.
- Re-grease the wire rope at the neck.
- Never use an assembly before the resin is fully hardened.
- Procedures in EN 13411-4 or ISO 17558 or equivalent should be followed.
- Socketing should always be executed by qualified and competent personnel only.

ADDITIONAL FOR FAST CONNECTOR SOCKETS

- The FCS Spin Resistant connector shall be used with non-rotation resistant wire rope and may be used with rotation resistant wire rope.
- The FCS standard (rotating) connector shall be used with non-rotating or cat 1. rotation resistant wire rope only.
- Normal socketing procedures for spelter sockets shall be followed.
- Remove seizing after and up to the bottom of the basket when the seizing is in contact with the housing.
- The lugs are not a lifting device; they are designed to fit a tool used to pull the connector through the reeving system with a standard shackle. One may leave the tool once assembled if clearance in the application allows for it.

ADDITIONAL FOR SUPER REEVE CONNECTOR SOCKETS

- The SCS Spin Resistant connector shall be used with non-rotation resistant wire rope and may be used with rotation resistant wire rope.
- The SCS standard (rotating) connector shall be



used with non-rotating or cat 1. rotation resistant wire rope only.

- The basket length differs from normal. Measure appropriately for required broom height. Seizing should match your working method.
- The broom should come up just below the threaded section. (About maximum 1/8d or 5mm which ever smaller).
- Use a cover to protect the thread.
- Resin penetration may be more difficult in the tight SCS buttons, esp. with large fill factor ropes with a large number of wires (e.g. high performance ropes like 35x7). Normal socketing procedures for spelter sockets shall be followed with the addition of the following recommendations for resin:
 - Do NOT use booster packages to speed up curing.
 - Reduce mixing time when possible, but keep resin mfg instructions.
 - At higher ambient temperatures we recommend to refrigerator cool the resin to delay curing / increase gel time. And if possible to cool the pre-assembly too to the same temperature as the resin. Follow resin manufacturers limitations.
- It is recommend to stay out of direct sunlight on hotter days.
- Suggest to use low viscous resin. (typ. found in smaller cans.)
- Suggest wire 'poking' around in the socket basket, as you pour, which should release air bubbles more easy and promote resin penetration to the bottom.
- To prevent air becoming trapped, consider pouring without putty at the bottom and placing the putty once the resin comes out at the bottom. (Two pair of hands needed.)
- Remove seizing after and up to the bottom of the basket when the seizing is in contact with the housing.
- The connector cap shall be secured after socketing by means of a high strength thread locking adhesive. (E.g. Loctite 270, etc.)
- The connector cap is not a lifting device; it is used to pull the connector through the reeving system with a standard shackle.
- The connector shall always be installed in the socket housing and used with the retainer properly mounted and secured.
- The SCS connector is not recommended for re-use.

APPROXIMATE RESIN VOLUMES

For wire rope Ø		Approximate resin volume
mm	inch	cc
6 - 7	¼	9
8 - 10	⅜	15
11 - 13	½	35
14 - 16	⅝	50
18 - 19	¾	80
20 - 22	⅞	120
23 - 26	1	160
27 - 30	1⅛	220
31 - 36	1½ - 1⅜	350
37 - 39	1½	425
40 - 42	1⅝	500
43 - 48	1¾ - 1⅞	700
49 - 54	2 - 2⅛	1200
55 - 60	2¼ - 2⅜	1450
61 - 68	2½ - 2⅝	1850
69 - 75	2¾ - 2⅞	2250
76 - 80	3 - 3⅛	3500
81 - 86	3¼ - 3⅜	4000
87 - 93	3½ - 3⅝	5000
94 - 102	3¾ - 4	7500
108 - 115	4¼ - 4½	10500
120 - 130	4¾ - 5	14000
135 - 140	5½	16000
141 - 153	5¾ - 6	20000
154 - 165	6¼ - 6½	26000
166 - 178	6¾ - 7	33000
179 - 191	7¼ - 7½	39000
192 - 204	7¾ - 8	48000

WARNINGS

- **ALWAYS CARRY OUT A VISUAL INSPECTION BEFORE USING A SOCKET AND PIN.**
- **NEVER USE A PART SHOWING CRACKS.**
- **DO NOT SIDE-LOAD A SOCKET.**
- **REPAIRS ARE NOT ALLOWED, FOR ANY REPAIRS CONTACT YOUR SUPPLIER.**
- **NEVER SHOCK-LOAD A SOCKET.**

WEDGE SOCKETS

- Always mount the loaded part of the wire in the centre line of the pin (see figures below).

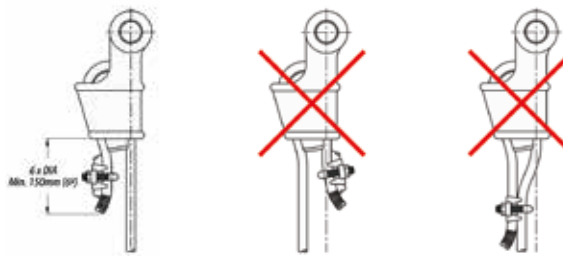

correct

incorrect

incorrect

Make sure you are using the correct house, rope and wedge size combination.



- Make sure you are using the correct house, rope and wedge size combination.
- Nominal intermediate rope sizes should be used with the biggest socket within the range.
- Secure properly the dead end with a wire rope clip.
- Do not attach the dead end to the live wire.
- The dead end should have a length of 6 times the diameter of the rope. Ensure that the wire rope and wedge are fully seated after the first load.
- A load may slip if the connection is not properly installed.
- Inspect the connection regularly.
- The efficiency of a 6 or 8 strand wire rope and most high performance ropes with a Ropeblock wedge socket connection is 80% of the MBL of the wire rope, but limited to the MBL of the socket.
- Check your wire rope supplier for efficiency rating details when used with high performance ropes or test the assembly type to determine efficiency.
- Follow recommendations for safe use in EN 13411-6.
- Suggest attaching the clip minimum about 2d distance from the body.

TAILGRIP WEDGE SOCKETS

- Follow recommendations for safe use in EN 13411-6.
- Check that the wire rope is suitable for the socket application.
- Check that socket, wedge and wire rope clip match to fit the wire rope size. The correct wire rope size can be checked with the Go - No Go feature, implemented in the wedge.
 - The wire rope MUST pass thru the 'Go' hole in the wedge.
 - The wire rope shall NOT pass thru the 'No-Go' hole in the wedge.

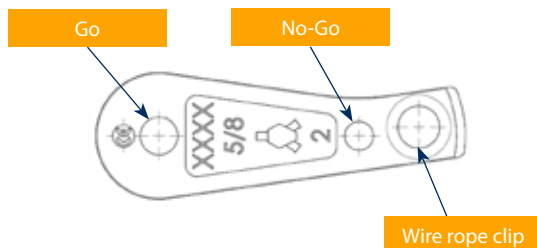

- After mounting the wire rope in a loop through the OWS socket, place the wedge correctly in the socket.

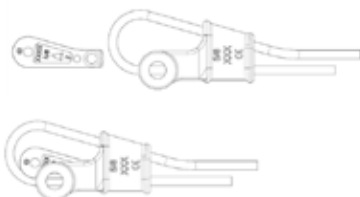

- Pre-tension the wire rope, so that wedge is fixed inside the socket housing.
- Mount the wire rope clip on the dead end section, gripping the tail of the wire rope.

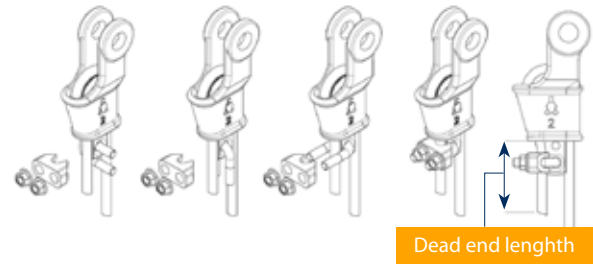

- The dead end length or tail length should be a minimum of:
 - **Standard 6-8 Strand Wire Rope**
Minimum of 6 rope diameters, but not less than 150mm.
 - **Rotation resistant Wire Rope**
Minimum of 18 rope diameters, but not less than 150mm.
- Tighten nuts on clip to recommended torque.

OWS Type	0,5	1	2	3	4	5	6	7
Wire rope clips Type*	10	13	16	19	22	26	30	34
Torque [Nm]	9	33	49	68	107	147	212	296

* Clips per EN 13411-5

SWAGE SOCKETS AND SLEEVES (FLEMISH EYE FERRULE)

- Swage Sockets and Sleeves are recommended for use on 6 x 19 or 6 x 37 IPS or XIP (EIP), XXIP (EEIP), RRL, FC, or IWRC wire ropes. They are also approved for use on galvanized bridge rope. They are not recommended for use on fibre core ropes without further measures.
- Properly applied Swage Sockets may reach an efficiency rating of 100% and shall have a minimum efficiency of 90% per EN 13411-8. This rating is based on the catalogue strength of wire rope. This can be limited by the minimum breaking load of the socket (MBL).
- Swaged sleeves should generate an efficiency of at least 90% per EN 13411-3.
- For further performance specifications, please contact Ropeblock.
- Swage sockets and sleeves are forged from special steel quality and heat treated for cold swaging.
- Proper swaging methods must be followed for all Swage Sockets and Sleeves.
- Always use the matching dies to the socket or sleeve.
- Ensure the dies are aligned and within the limits



for admissible wear.

- The position of the rope end should be verified prior to swaging and after swaging.
- Multiple progressive pressings are required to prevent flash, which could develop into a permanent mark or possibly a crack in the sleeve. A color change will not indicate proper swaging.
- A light oil lubricant should be applied to each die and wiped clean after swaging.
- For swaging practice details contact the die manufacturer.
- Always verify after swaging dimensional limits.
- Each swaged termination shall be free of any flaws and surface defects and shall not exhibit any sharp edges or rough surfaces.
- The outline of EN 13411-3 / EN 13411-8 or equivalent should be followed.
- Caution: Proper swaging practices are the responsibility of the sling manufacturer.
- Before using Swage Sockets or Sleeves with other type lay, construction or grade of wire rope, it is recommended that the termination be type tested to prove the adequacy of the assembly.
- For Flemish eye constructions we recommend to follow internationally prescribed construction, safety criteria and inspection procedures. (e.g. EN 13414, ISO 8792 and ASME B30.9).

TURNBUCKLES

GENERAL

Safety measures should be taken into account when using turnbuckles. Carefully follow all instructions.

Important information can be found below.

Turnbuckles are primarily used as adjustable hardware to tension two points and/or possibly adjust the distance between two points.

All turnbuckles have a Factor of Safety (FoS) of 5:1.

Ropeblock closed body trapezium thread turnbuckles (TR series) may be used for lifting, general rigging and lashing.

Open body UNC thread and closed body metric thread turnbuckles should be used for general rigging and lashing only.

Ropeblock turnbuckles provide adequate toughness and ductility and should be considered fit for purpose until minimum operating temperatures of -40°C in general service application. Check your application specific criteria with the set design temperature against the specifications set forth in de applicable design standards or rules.

Ropeblock turnbuckles can be used with below approximate limited work load capacity rating for continuous service at these elevated temperatures:

- ≤110°C with 100% capacity rating
- ≤150°C with 92% capacity rating
- ≤200°C with 83% capacity rating
- ≤250°C with 75% capacity rating
- ≤300°C with 67% capacity rating

For intermittent use at elevated temperatures the temperature the turnbuckle will reach should be determined. Use above 300°C is not recommended; Contact Ropeblock for further guidance. Please note that the grease on the thread will lose effectiveness above ±80°C.

Dimensional tolerances depend on the manufacturing techniques applied and are different between machined components (pins) and forged components (bodies and end fitting). Also surface finish e.g. hot dip galvanizing or even paint may add to the overall thickness and fork distance. Please contact Ropeblock for further guidance and a dimensional tolerance sheet. Turnbuckles should be tensioned in line only (straight pull), unless designed specific for that purpose. Turnbuckle connection points may be used as an orientating hinge-point.

To prevent excessive wear and additional bending they should not be used as a friction hinge point under load. Further design evaluation and creating a proper functional hinge point is advised.

Check for potential pin rolling with axial movement that may develop depending operation.

Check your application for the required take-up length and used connecting points (jaw, stud-eye, oblong-eye, rod or stud ends, hook, etc.).

Depending your application select proper the retaining option (contra nuts or locking/retainer bolts). Consider the rotational characteristics of wire rope where applicable. After assembly, make sure locking nuts or locking/retainer bolts are properly tightened. Use proper inspection routines when used on vibrating equipment. A yearly inspection as a minimum is advised.

The absolute minimum thread engagement is 1xd (with d being the thread size). This must be measured on both sides of the turnbuckle and based on the actual dimensions.



Protect the turnbuckle against corrosion and maintain proper grease levels on the bare metal threads.

- ❑ **ALWAYS CARRY OUT A VISUAL INSPECTION BEFORE USING A TURNBUCKLE.**
- ❑ **NEVER USE A PART SHOWING CRACKS OR DAMAGES.**
- ❑ **DO NOT SIDE-LOAD A TURNBUCKLE.**
- ❑ **REPAIRS ARE NOT ALLOWED; FOR CONSULTATION CONTACT ROPEBLOCK.**
- ❑ **NEVER SHOCK-LOAD A TURNBUCKLE.**

PROOF TESTING

Turnbuckles can be individually proof tested on request. The default proof load value is twice the catalogue WLL of the turnbuckle and $1,22 \times WLL + 20$ for WLL above 25t for the trapezium turnbuckles. Higher or different values and/or individual testing for UNC or metric turnbuckles upon request.

RIGGING ACCESSORIES

To other rigging accessories such as tri-plates, split overhaul balls, pad-eyes, devils claws, etc. the limitations of use and further relevant sections of this warning and safety document apply and are to be used in a straight pull only. Contact Ropeblock for guidance if so required.

CERTIFICATION

GENERAL

The following certificates or other documents, where applicable or so ordered, have been provided with the product:

- Declaration of compliance with the order EN 10204 2.1.
- Test report EN 10204 2.2 (Batch (proof load) test (according to ILO 152).
- Inspection certificate finished product EN10204 3.1 (Individual product (proof load) test (according to ILO 152).
- Inspection certificate finished product EN10204 3.2 (Individual product (proof load) test (according to ILO 152), including conformity survey by a 3rd party).
- Hook material certificate EN 10204 3.1.
- Material certificate EN10204 3.1 for main load bearing part.
- Material certificates EN10204 3.1 for all load bearing parts.
- Documents per contract / etc.

INSPECTION AND MAINTENANCE

Inspections should be carried out daily or weekly or, if your Ropeblock product is used infrequently, each time it is used by the operator. Examination of the product by a competent and trained person should be carried out monthly to check for damage, corrosion and the free movement of sheave and safety latch. Thorough examination of the product by a competent and trained person should be carried out annually or periodically depending on usage intensity as seen fit by the application designer or owner.

DEPENDING ON LOCAL REGULATIONS, PRODUCTS (E.G. HOOK AND HOOK-NUT) ARE TO BE DISMANTLED, INSPECTED AND RE-TESTED (PROOF LOADED) AT LEAST EVERY 4 OR 5 YEARS.

WITH THE MANDATORY DISMANTLING INSPECTION OF THE HOOK, THE OVERALL BLOCK AND COMPONENTS WITH SHEAVE AND BEARINGS SHOULD BE INSPECTED FOR PROPER FUNCTIONING AND CONDITION.

Particular attention shall at least be paid to the following:

- Wear in the hook, center pin, becket or threads of hook and nut.
- Play in the bearings.
- Spacer bolts, nuts and lynch pins.
- Cracks in welds.
- The condition of retainers, safety latch and grease nipples.
- Wear in holes in side plates and becket. / Wear of holes and play in the bearing supports.
- Worn sheaves.
- Contamination (dust, dirt, humidity) or corrosion of the roller bearings.
- Deformed or missing items or the presence of secondary retention.
- Register of previous relevant maintenance and repairs.

If cracks or heavy gouges are apparent, the crane block shall not be used and competent opinion sought. Repairs should be undertaken by grinding smooth in the surrounding area only. If it is grooved and its section reduced by more than 5% from its nominal dimension, the item shall be replaced. NDT of hooks shall follow surface inspection in accordance with EN 10228-1 class 3. The hook shall be replaced if its throat opening is enlarged by more



than 10% from its certified dimension (Y-measurement).

By default and as a general rule for all sheaves, wear of sheaves should be evaluated both against 10% wear of nominal section thickness and 0.15xd in accordance with the DIN 15063 standard. For further detailed guidance on your particular sheave and application, contact your sales representative. Repair or modification by welding, flame torch, or other significant heat inducing method is strictly prohibited unless prior consent in writing has been obtained from Ropeblock.

Comprehensive and more intense regular examination must be carried out when your product is used in severe or corrosion inducing environments. High-grade steels may be susceptible to hydrogen embrittlement and loss of ductility. Check for cracks. Where stainless steel bolting is used, check for cathodic corrosion. If your block was fitted with retaining or securing wires, check that these are present, intact and correctly fitted.

If the holes in the cross head, side plates, becket or eyes are enlarged by more than 5% from nominal, the part shall be replaced. Items that are out of original tolerance, bent, deformed or misaligned shall be replaced. Employ sound engineering practice to evaluate and decide. Contact your sales representative for advice.

Any replacement parts shall be purchased from Ropeblock B.V. All repairs shall be carried out by trained and competent personnel and great care shall be taken in the re-assembly of the equipment and fastening or securing parts such as grub screws, lynch pins, etc. Check and refit only correct sizes and threads. Nyloc nuts, should be replaced.

When properly maintained and kept at adequate grease levels, cylindrical roller bearings are designed to run one million cycles under their full dynamic catalogue rating and were selected to suit the perceived application. The thrust bearing is statically rated. Depending on the actual intensity of use and cumulative load throughout the product's life, fleet angles and environmental influences, the number of cycles could be higher or lower. With it, the effective life of the product itself compared to its original design life can be affected. Under severe (environmental, usage) conditions, more intense

inspection and maintenance should be implemented.

As a general rule, sheaves, cross heads, bearings and bodies should be greased through nipples at these positions at least once a month or every 250 hours of service. Lubricate until new grease is visible. Heavy duty or high performance equipment should receive relubrication weekly. For sub-sea equipment, always remove the air-vent plug before the greasing operation to prevent jamming.

Bronze bearings should be greased every two weeks, or after 8 hours of continuous service. Check your product specifications or drawings for the location on your Ropeblock product.

Plain journal sheave bearings for submersible use must be greased less than one week prior to their first use. This is to reactivate the proper functioning of the bushing and combat potentially ageing and solidified grease.

Unless stated otherwise, re-lubrication, as well as maintenance, should be done with lithium or lithium/calcium based EP2 grease with a strong adherence to metallic surfaces, excellent protection against corrosion and resistance to wear and should be suitable for the required operating temperatures. Retesting shall be done according to the requirements in the original test certificate and will only apply to a fully reeved component.

FOR SPARE PARTS OR INFORMATION, OR IN THE EVENT OF ANY PROBLEMS OR DOUBT, ALWAYS CONTACT YOUR SALES REPRESENTATIVE OR ROPEBLOCK B.V.

SPARE PARTS LIST

The recommended spare parts list indicates when the parts of the crane block should be replaced, or at least inspected and cleaned. If you do not have this, it is available on request.

HIGH QUALITY AND SAFE COMPONENTS FOR THE GLOBAL LIFTING AND WIRE ROPE INDUSTRY.

ROPEBLOCK.COM





EXPERIENCE THE BENEFIT OF SMART ENGINEERING



ROPEBLOCK

ROPEBLOCK.COM

Copyright © 2023
Published by Ropeblock B.V. All rights reserved.
No part of this publication may be reproduced,
stored in a retrieval system or transmitted in any
form or by any means electronic, mechanical,
photocopying, recording or otherwise without
the prior written permission of the publisher.

Printing and typing errors reserved.
Notice: No responsibility is assumed by the
publisher for any injury and/or damage to
persons or property as a matter of products
liability, negligence, or otherwise, or from any
use or operation of any methods, products
or ideas obtained in the information herein.



8125 Saran Drive, Playa del Rey, CA 90293

T: 310.448.5444

E: sales@awrinc.com

associatedwirerope.com