



WATERMAN
SUPPLY COMPANY
MARINE & INDUSTRIAL EQUIPMENT



2025

**SUPPLIER OF HEAVY MARINE EQUIPMENT
SINCE 1951**

ABOUT WATERMAN SUPPLY

Waterman Supply is extremely proud to have been serving the marine, oil field, construction, and industrial markets for over 65 years. We are a direct distributor of Marine & Industrial Equipment, and stock a tremendous inventory of Anchors, Anchor Chain, Hardware, Fenders & Buoys, Dock Equipment, Deck Fittings, Marine Doors and Hatches, Crane Blocks, Overhaul Balls, Wire Rope Sockets and more. We carry new and used products from both foreign and domestic suppliers.

Our office and main warehouse is in the heart of the ports of Los Angeles and Long Beach. We also maintain a vast inventory of products in the Gulf Coast to further service our customers in the Gulf Area, East Coast and around the world.

Please do not hesitate to get in touch with us for any of your specific requirements or questions regarding our products.



GENERAL CAUTIONS OR WARNINGS

Ratings shown in this literature are applicable only to new products.

Load limit ratings indicate the greatest force or load a product can carry under usual environmental conditions. Shock loading and extraordinary conditions must be taken into account when selecting products for use in a system.

The Working Load Limit or Design Factor of each product may be affected by wear, misuse, overloading, corrosion, deformation, intentional alteration and other use conditions. Regular inspection must be conducted to determine whether use can be continued at the catalog assigned work load limit, or withdrawn from service.

Side loading must be avoided, as it exerts additional force or loading which the product is not designed to accommodate.

Hook latches are made to retain loose slings or devices under slack conditions. they are not intended to be anti-fouling devices; therefore, the latch must be prevented from supporting and load. Regular latch inspection is recommended to ensure proper operation. The information in this catalog was obtained from sources which we believe are reliable. The information, however, is provided without any representation or warranty, expressed or implied, regarding its accuracy or correctness.

Waterman Supply, Co. assumes no responsibility for the use or misapplication of any products sold by this firm. Our products are sold with the express understanding that the purchaser and/or user is thoroughly familiar with the correct application and proper use for which it is being purchased.

Note: Consult OSHA - Federal - Military - or State Regulations before using any product in this catalog.

TABLE OF CONTENTS

Anchors	1
Blocks	22
Buoys	100
Chain	117
Chain & Anchor Fittings	129
Cordage	156
Deck Fittings	166
Dock Fittings	190
Doors/Hatches	223
Fenders	253
Hardware	280
Lanterns	298
Sockets	317
Spillboom	339
Towing	343

ANCHORS

**GIGANTIC INVENTORY
USED AND NEW WITH CERTIFICATES
(A.B.S. - LLOYDS - DNV - ETC.)**

DOMESTIC - IMPORTED

RENT OR SALE

ANCHORS

L.W.T

WORKBOAT

STOCKLESS TYPE - HALL TYPE

MUSHROOM TYPE - EELLS

KEDGE TYPE

NAVY PATTERN ANCHORS

AC-14 - SPEK TYPE

HIGH HOLDING POWER

**STOCKS IN THE
WEST COAST
EAST COAST
GULF COAST**

GIVE US A CALL

310.522.9698

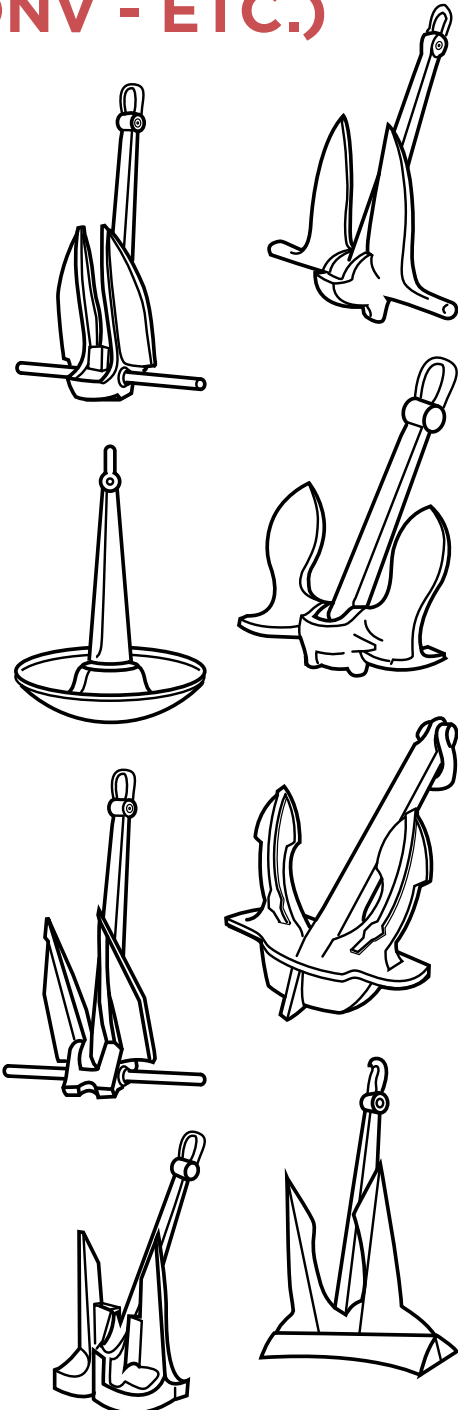

SELECTION

Because the anchor is the key to effective mooring or anchoring it is essential to know what to expect from various types. Any anchor's performance is dependent first upon its ability to bite into the bottom through the ploughing effect of its flukes and secondly upon its ability to maintain a continuous resistance to drag once it is implanted in the bottom.

Therefore, the optimum design of an anchor is influenced primarily by the specific composition of the ocean floor, which is generally categorized into three groups: mud, sand, and rock or marl. Mud varies the most in consistency and offers little resistance to dragging forces. Sand is almost ideally consistent and anchors specifically designed for sand bottoms reach excellent holding efficiency. On the other hand rock or marl is very poor holding ground, where an anchor's dead weight is its only asset.

An anchor's efficiency is expressed in holding-power ratio, that is the holding force per anchor weight. The proof test

involves applying a static load to the assembled anchor to test its structural design and material properties as related to the holding force.

The holding power of an anchor is affected greatly by the angle of its flukes. In order for the flukes to enter the bottom of an angle that will allow the crown or head to penetrate to a depth producing maximum efficiency, the angle of the fluke to the shaft should approximate 50 degrees in the mud bottoms and 30 degrees in sand.

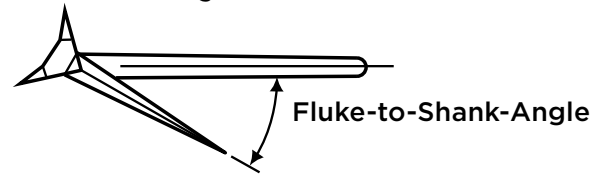

Anchor holding-power is also dependent upon other bottom conditions, the duration of drag and the ratio between the length of the mooring line and the water depth.

Recommended Applications ¹	Stockless	Snug-Stowing®	Lightweight	LWT® Danforth	Stato®	Moorfast®	Boss
Offshore Rig Mooring		X	X	X	X	X	
Supply/Support Vessels		X	X				
Pipelay Barges	X					X	
Fixed Mooring			X	X	X	X	X
Commercial Ships	X	X					
Tugboats	X	X	X				
Supertankers	X						
Minimum Performance Characteristics							

MUD	Holding Power Ratio ²	3:1	5:1	9:1	9:1	9:1	9:1	32:1
	Depth of Penetration (ft)	9-10	17-20	17-20	17-20	17-20	17-20	35-40
	Breakout Force Ratio	2:1	3:1	5:1	5:1	5:1	5:1	6:1
	Fluke-to-Shank Angle (degrees)	45°	43°	30°	30°	23°	34°	34°
SAND	Holding Power Ratio ²	7:1	14:1	20:1	20:1	20:1	20:1	25:1
	Depth of Penetration (ft)	3	6-8	6-8	6-8	6-8	6-8	10-15
	Breakout Force Ratio	2:5:1	6:1	8:1	8:1	8:1	8:1	12:1
	Fluke-to-Shank Angle (degrees)	45°	43°	30°	30°	34°	34°	34°
Optional Swivel Shackle ³				X	X	X	X	
Padeye for Pendant Buoy Line				X	X	X	X	X

¹ These recommendations are based upon usage practice. Deviations are acceptable.

² These are minimum values only; actual bottom conditions could increase holding power considerably.

³ Swivel shackles can be used to replace anchor shackle, anchor connecting link, and swivel.

WE ARE DIRECT IMPORTERS AND
FACTORY DISTRIBUTORS

WE HAVE ONE OF THE LARGEST SELECTIONS OF NEW AND USED ANCHORS IN THE COUNTRY FOR IMMEDIATE DELIVERY. DIRECT FACTORY SHIPMENTS ALSO AVAILABLE AT NO EXTRA COST. WE KEEP OUR STOCKS OF PRODUCTS IN THE WEST COAST, GULF COAST AND EAST COAST TO EXPEDITE DELIVERIES. **GIVE US A CALL AT 310.522.9698.**

SELECTION

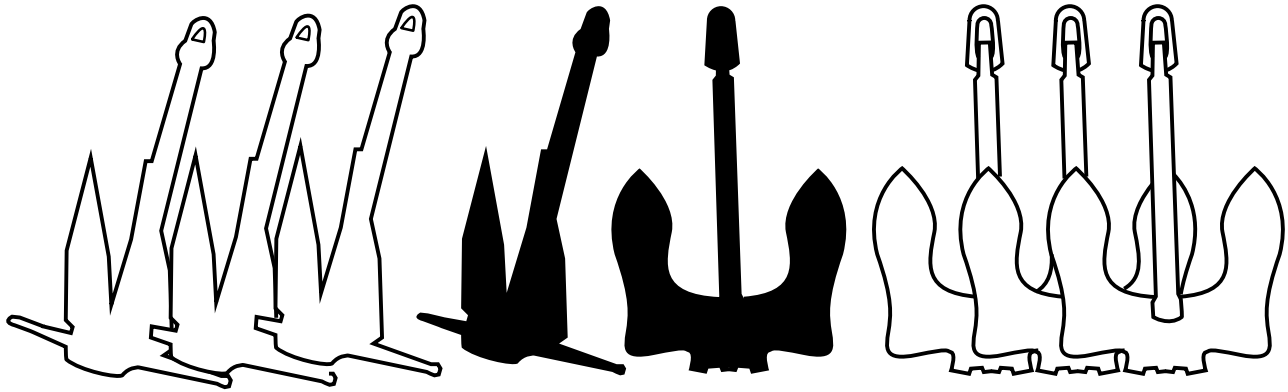

Optimum design of anchor is influenced by the specific composition of the ocean floor. Basically, we categorize the ocean bottoms into three groups:

1. Mud, or silt, which varies the most in consistency and offers little resistance to forces.
2. Sand, ideally the most consistent, and where anchors specifically designed, reach excellent holding efficiency.
3. Rock, or Marl, poor holding ground where an anchor's dead weight is its only asset.

The efficiency of an anchor in a given test is expressed in terms of "Holding power" per pound of its own weight, not in "Proof test" which indicates physical properties of the material.

The fluke angle of an anchor has a definite effect upon the "Holding Power". The flukes should enter the bottom at an angle that will allow the crown, or head, to penetrate to a depth which can produce maximum efficiency. Additionally, we have determined the following:

1. The angle of fluke penetration in mud bottom should be approximately 50°.
2. In sand the penetration angle should be in the area of 30°.
3. For anchoring in various bottoms a compromise approximating 43° is desirable.

Other considerations in selecting an anchor should include:

1. Convenience for handling and stowing.
2. Aptitude for taking hold.
3. Physical strength.
4. Freedom from fouling, which all anchors do, but some in lesser degrees.
5. Influence developed by the chain's catenary, which absorbs shock loads, and lowers the angle of pull at the anchor by its weight.

The anchor is the key to effective anchoring or mooring. It is essential to know what to expect from various anchors. The resistance of an anchor being dragged through a soil has been considered as occurring in two stages: first, biting into the bottom due to the ploughing effect of the flukes, and secondly, maintaining a continuous resistance to drag after it is planted into the bottom.

Holding power is directly proportional to projected fluke area, and shear strength of the bottom material, and inversely proportional to penetration-area resistance. In many cases, a smaller anchor with favorable fluke area to weight ratio is more dependable than a heavier anchor.

Holding power for the two most widely used anchors are as follows:

1. Stockless Type anchors in sand develop a holding power to weight ratio of seven to one. In mud it develops three to one. The angle of penetration in both cases is 45°.
2. Lightweight Type anchors in sand develop a holding power to weight ratio of twenty to one, with the angle of penetration being 30°. In mud it develops nine to one with the angle of penetration being 50°.

The depth of penetration in all preceding cases is compiled from three to seven feet in sand, and from seventeen to twenty feet in mud. All calculations incorporate a 0° scope angle.

TYPES OF ANCHORS

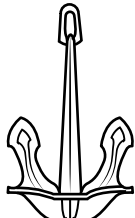

Hall

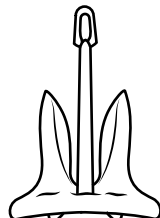

AC14

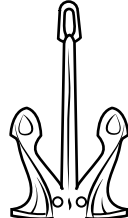

Spek

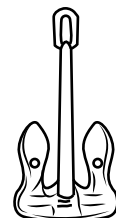

Byers

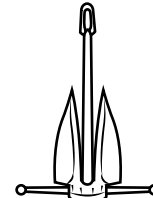

Danforth

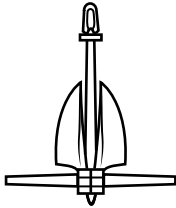

LWT

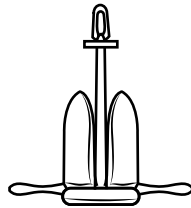

Moorfast

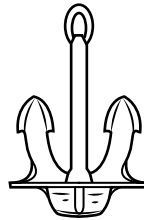

Union

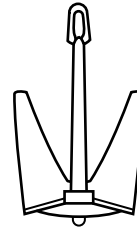

Pool

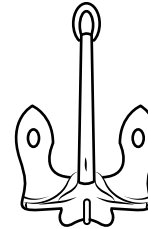

Navy

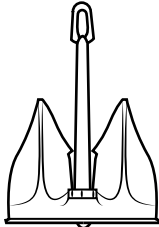

Norshore I

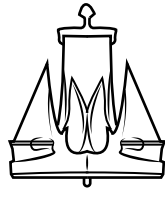

Norshore II

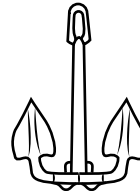

KLIP



FOB

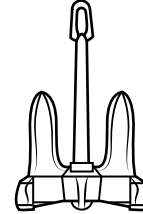

ZY-6

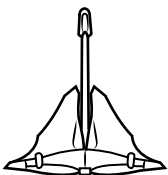

Deepsy

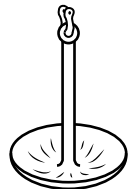

Mushroom



Bruce

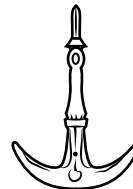

Kedge

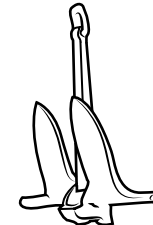

Snug Stow

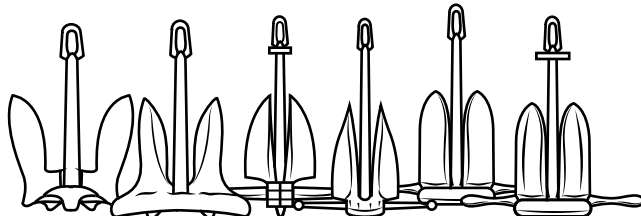

8 tons Stockless 4.5 ton AC 14 4.5 ton LWT 4 ton Danforth 4 ton Moorfast 3 ton Stato

Anchors with identical holding power drawn at the same scale thus showing the difference in weight.

Various anchor types with equal weight and scale.

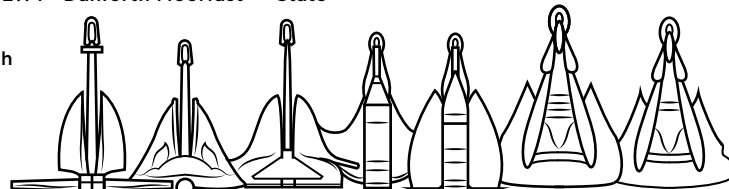

Danforth Delta Anchor Stevin MK3 Bruce TS Bruce FF Stevpris Stevshark

TYPES OF ANCHORS FROM AROUND THE WORLD

- | | | |
|----------------|-----------------------------|--|
| No. 1 | WORKBOAT OR DANFORTH TYPE | |
| No. 2 | L.W.T. OR LIGHTWEIGHT TYPE | |
| No. 3 | BYERS TYPE STOCKLESS ANCHOR | |
| No. 4 | SPEK TYPE ANCHOR | |
| No. 5 | NAVY TYPE STOCKLESS | |
| No. 6 | STANDARD STOCKLESS ANCHOR | |
| No. 7-8 | MUSHROOM TYPE | |
| No. 9 | BRUCE TYPE | |
| No. 10 | KEDGE OR ADMIRALTY | |
| No. 11 | AC-14 TYPE | |
| No. 12 | STATO TYPE | |
| No. 13 | DELTA TYPE ANCHOR | |
| No. 14 | POOL TYPE ANCHOR | |
| No. 15 | SNUG STOWING | |
| No. 16 | HALL TYPE STOCKLESS ANCHOR | |
| No. 17 | SINGLE FLUKE / KEDGE TYPE | |

WORKBOAT ANCHOR

ANCHOR WEIGHT	A	B	C	D	E	F	PROOF TEST
25	31-3/4	27-3/8	19-3/8	3-7/16	3/8	11-5/8	1600
50	40	34-3/8	24-3/8	4-3/8	7/16	14-5/8	2900
75	45-3/4	39-1/2	27-7/8	5	1/2	16-13/16	5000
100	47-1/2	41-1/8	28-5/16	5-1/4	3/4	17-1/2	5972
150	49	42-1/2	29-7/8	5-5/8	3/4	18-7/8	8300
200	52-1/2	45-1/2	33	6-1/8	7/8	20-1/2	10100
300	56	48-1/2	35-1/4	13-1/2	1-1/8	23-1/4	13000
400	58	50	39-9/16	13-7/8	1-1/8	24-1/8	15600
500	63	54-1/2	39-3/4	15-1/8	1-1/2	26-1/4	18100
750	67-1/2	58-1/2	42-1/2	16-1/2	1-1/2	28-1/4	24100
1000	72	62	45-3/8	18-3/4	2	30	30000
1500	77	70-7/8	48-1/2	19-3/8	2	32	41400
2000	83	71-3/4	52	22-5/8	2-1/2	35-3/4	52300
2500	89	84-1/2	56	13-7/8	2-1/2	36-1/2	62270
3000	94	89	59	14-3/8	3	38-7/8	72500
3500	99	94	62-1/2	15-1/8	3	45-3/8	81800
4000	104	98-3/4	65-1/2	15-3/8	3	41-1/4	90700
5000	112	106-1/2	70-1/2	18	3-3/8	45-1/4	107000
6000	118	112	74	18-5/8	3-3/4	47-1/2	121300
8000	129	122-1/2	77-3/8	20-1/4	4-1/8	52-1/16	145600
10000	138	131	87	21-7/8	4-1/2	55-7/8	165600
12000	145	145	91	23	4-3/4	58-3/4	184700
14000	152	152	95-3/4	24	5	61-5/8	205000
16000	160	160	101	25-1/4	5-1/4	64-7/8	222700
20000	172	163	108-3/8	27-1/4	5-5/8	69-1/2	249400
30000	197	187	112	31-1/4	6-1/2	80-1/2	319400

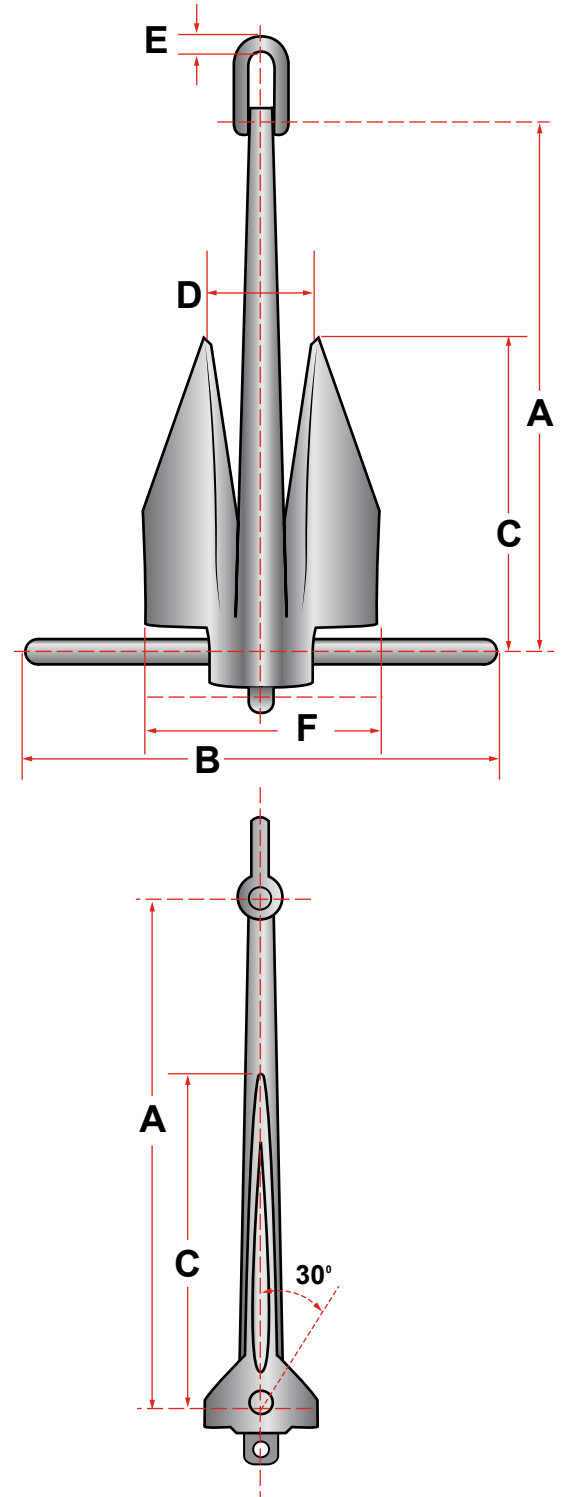

All specifications in pounds and inches.
Intermediate sizes may be furnished on request.

LIGHTWEIGHT (LWT) ANCHOR

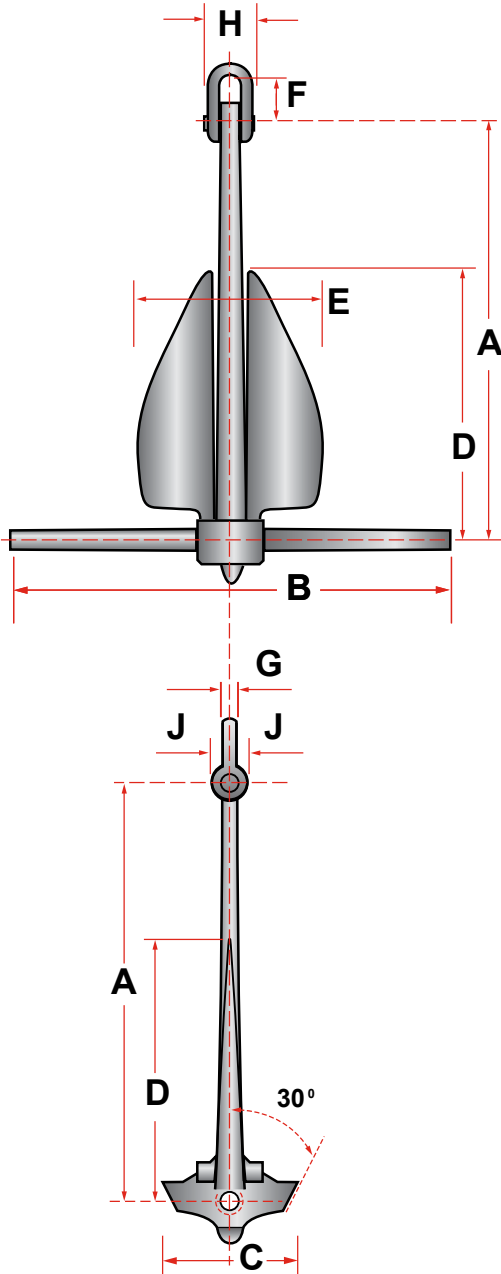

ANCHOR WT	A	B	C	D	E	F	G	H	J	PROOF TEST
100	41-1/2	39-1/2	12-3/46	24	15-5/8	3-3/4	7/8	3-3/8	2-1/4	5500
150	46-3/4	44-1/2	13-11/16	27	17-3/8	5-1/2	1	4	2-3/8	6800
200	47-1/2	45	14-3/16	29	18-7/8	5-1/2	1	4	3-1/8	10100
250	47-1/2	45	14-9/16	29	18-7/8	5-1/2	1	4	3-1/8	11600
300	53	50	16-5/16	32-1/2	21-1/4	7	1-1/4	5	3-1/4	13000
350	53	50	16-11/16	32-1/2	21-1/4	7	1-1/4	5	3-1/4	14300
400	57-1/2	54-1/4	17-3/4	35-1/4	23	7	1-1/4	5	3-1/2	15600
450	60	56-1/2	18-3/8	36-3/4	24	7	1-1/4	5	3-3/4	16900
500	61-1/2	58-1/2	19	37-1/2	24	7-1/2	1-1/2	6	4-1/4	18100
750	69	64-1/2	21-1/8	42	28-7/16	7-1/2	1-1/2	6	4-7/8	24100
1000	75	71	24-1/2	46	29-1/4	9-3/4	2	8	5-1/4	30000
1500	86-1/2	58-1/2	27-5/8	53	31-7/8	12	2-1/2	9-1/2	6	41400
2000	92-1/2	85	30	56-1/2	37-1/4	12	2-1/2	9-1/2	7	52300
3000	108-1/2	104	34-3/4	66	40-3/8	15	3	11	7-3/4	72500
4000	116	110	37-1/2	71	44	15	3	11	9	90700
5000	118	112	38-3/4	72	44-3/4	17	3-1/2	12-1/4	9-1/2	110700
6000	124	118	41	76	47-1/4	19	4	13-3/4	10-1/4	121300
7000	124	118	41	76	47-1/4	19	4	13-3/4	10-1/4	134300
8000	128	121	43-1/2	78	50-1/4	19	4	13-3/4	12	145600
9000	133	126	45-1/4	81-1/8	52-1/4	19	4	13-3/4	12-1/2	155800
10000	144	137	49	88	55-1/4	22	4-1/2	15-3/4	13	165800
11000	144	137	49	88	55-1/4	22	4-1/2	15-3/4	13	174600
12000	146	138-1/2	49-3/4	89-1/8	57-3/8	22	4-1/2	15-3/4	13-3/4	184700
13000	154	146	52-1/2	94	60-1/2	24	5	17-1/2	14-1/2	194300
14000	154	146	52-1/2	94	60-1/2	24	5	17-1/2	14-1/2	203000
15000	157	149-1/4	53-5/8	96	61-7/8	24	5	17-1/2	14-7/8	213700
16000	161	152-1/2	54-7/8	98-1/4	63-1/4	24	5	17-1/2	14-1/8	222700
17000	164	155-1/2	56	100	64-1/2	24	5	17-1/2	15-1/2	230000
18000	167	158-1/2	57	102	65-5/8	24	5	17-1/2	15-3/4	238600
19000	170-1/2	161-3/8	58	104	66-3/4	25	5-1/2	20	16	244100
20000	173	164	59	106	68	25	5-1/2	20	16-3/8	249400
25000	191	178	67-1/4	116	75	26-1/2	5-1/2	20	16	282500
30000	198	189	67-1/2	121	78	29	5-1/2	20	17	319400
35000	208	199	71	127	82	30 1/2	6	21	18	353750
40000	218	240	75	131	86	32	6	24	20-1/2	386400
45000	227	250	78	136	89	33	6-1/4	26	22	413825
50000	235	260	81	141	92	34	6-1/2	27	23	448300
60000	250	278	86	150	97	36	6-1/2	29	24	506200
70000	264	290	91	157	103	38	7	30	26	561400
80000	275	304	95	165	107	40	7-1/2	31	27	613400
90000	287	317	99	172	112	41	8	33	28	690000
100000	296	328	102	178	116	43	8	34	29	767000

All specifications in pounds and inches.
Intermediate sizes may be furnished on request.

STANDARD STOCKLESS ANCHOR

ANCHOR WT	A	B	C	D	E	F	G	H	J	PROOF TEST
200	27	18	9-1/2	15-1/8	5-1/8	5-1/2	1	5	4	8300
300	32	23-1/4	11-11/16	17-1/4	6-11/16	5-1/2	1	5	4-1/2	10900
400	32	25-3/4	13	19	7	5-1/2	1	5	4-1/2	13000
500	35	26-1/2	14	20	7	7	1-1/4	6	5-1/2	15000
700	38	29-1/2	15-5/8	23-1/2	8-1/8	7	1-1/4	6	5-3/4	19600
775	38	32	16-7/8	24-3/4	8-5/8	7	1-1/4	6	5-3/4	20050
900	42	32	17	24	9	7-1/2	1-1/2	6-1/2	6-1/2	22300
1000	42	33-5/8	18	25-1/8	9-3/4	7-1/2	1-1/2	6-1/2	6-1/2	24100
1260	46	36-3/8	18-3/4	28-3/8	9-7/8	8-1/2	1-3/4	7-1/2	6-3/4	28800
1430	49	39	20	29-7/8	10-3/4	9-3/4	2	8-1/2	7	31700
1540	49	40	20-1/2	30-1/2	11	9-3/4	2	8-1/2	7	33600
1600	49	40	20-1/2	30-1/2	11	9-3/4	2	8-1/2	7	34600
1750	52	41-1/2	21	33-1/4	11-3/8	9-3/4	2	8-1/2	7-1/4	37200
1875	52	43	22	34-3/4	12	9-3/4	2	8-1/2	7-1/4	39300
1950	52	43	22	34-3/4	12	9-3/4	2	8-1/2	7-1/4	40600
2000	58	44-3/4	23	33-3/8	12-1/8	9-3/4	2	8-1/2	7-1/2	43100
2500	58	44-3/4	23-1/4	33-3/8	12-1/8	9-3/4	2	8-1/2	7-1/2	49700
2800	58	48	25	35-7/8	13	9-3/4	2	8-1/2	7-1/2	54500
3000	64	47	25-1/2	36	12-3/4	12	2-1/2	10	8-3/4	57700
3500	64	52-3/4	27-1/2	39-1/2	14-1/4	12	2-1/2	10	8-3/4	65200
4000	70-5/8	53-1/4	27-1/2	39-1/4	14-1/2	12	2-1/2	10	9-1/2	72600
4500	70-5/8	56-3/4	29	42	15	12	2-1/2	10	9-1/2	79700
5000	76	57-1/2	30	42	15-5/8	15	3	12	10-1/4	86500
6000	76	63-1/2	33-1/4	47	17-1/4	15	3	12	10-1/4	99100
6300	76	63-1/2	33-1/4	47	17-1/4	15	3	12	10-1/4	102500
6500	82	63-1/2	33	47-5/8	17-1/4	15	3	12	10-3/4	105000
6750	82	65	33-3/4	48-3/4	17-5/8	15	3	12	10-3/4	108000
7000	82	66-5/8	34-3/4	49-3/4	18	15	3	12	10-3/4	110500
7600	82	67-1/2	34-3/4	49-3/4	18-3/8	15	3	12	10-3/4	117000
8100	93-1/2	66-1/4	34-1/4	48-7/8	18-1/4	17	3-1/2	13-1/4	11-1/2	122500
8600	93-1/2	68-1/2	35-3/4	50-1/2	18-1/2	17	3-1/2	13-1/4	11-1/2	127500
9000	96	70-1/4	36-3/8	51-3/4	19-1/8	17	3-1/2	13-1/4	11-1/2	131500
10000	96	75-1/2	39	58	21	19	4	14-3/4	12	140500
11000	96	75-1/2	39	58	21	19	4	14-3/4	12	148500
12000	96	76-3/4	40	58	20-3/4	19	4	14-3/4	12	156000
13000	98	76-3/4	40	58	20-3/4	19	4	14-3/4	12	163500
14000	103	80-1/2	44	60	22-1/4	19	4	14-3/4	13	170500
15000	103	86	46	65	24	19	4	14-3/4	13	177000
16000	108	86	46	65	24	19	4	14-3/4	13	185000
18000	112	88-1/4	48-1/4	65-5/8	24-3/4	22	4-1/2	16-3/4	13	200000
18900	112	88-1/4	48-1/4	65-5/8	24-3/4	22	4-1/2	16-3/4	13	207200
20000	112	96	50	72	26	22	4-1/2	16-3/4	14	214000
25000	120	103	53-3/4	77-1/2	28	22	4-1/2	16-3/4	15	243000
30000	128	110	57-1/4	82-1/2	29-7/8	24	5	18-3/4	16	266000
35000	135	116	60	87	31-1/2	25	5	19	17	292000
40000	140	121	63	91	32	26	5-1/2	20	17-1/2	320000
45000	147	126	65	94	34	27	5-1/2	21	18	345500
50000	152	131	68	99	35	28	6	21-1/2	19	371000

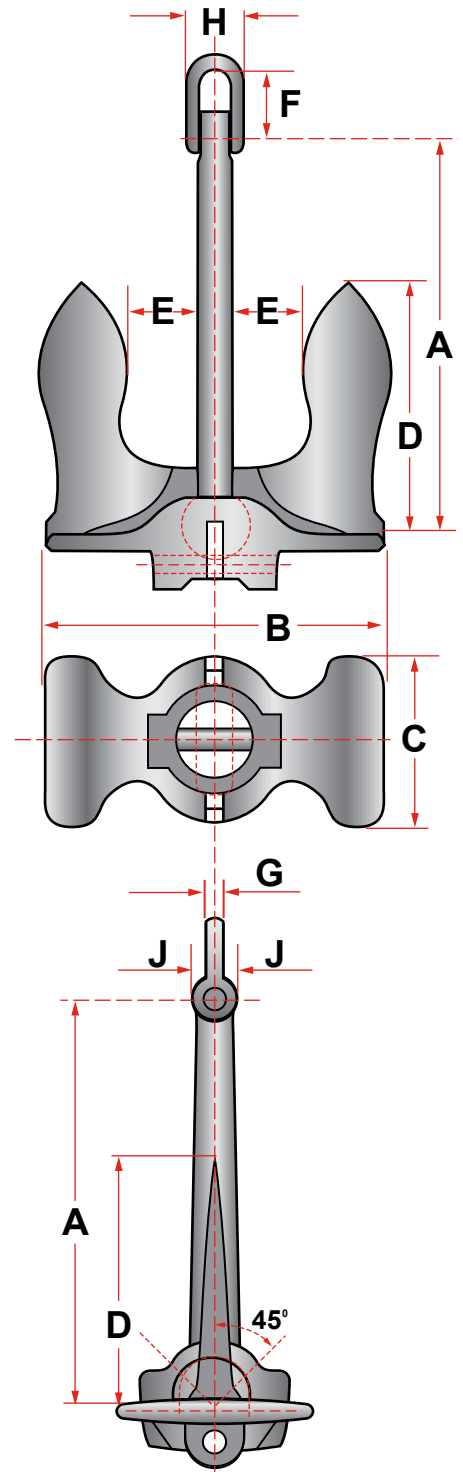

All specifications in pounds and inches.
Intermediate sizes may be furnished on request.

U.S. NAVY STOCKLESS ANCHOR

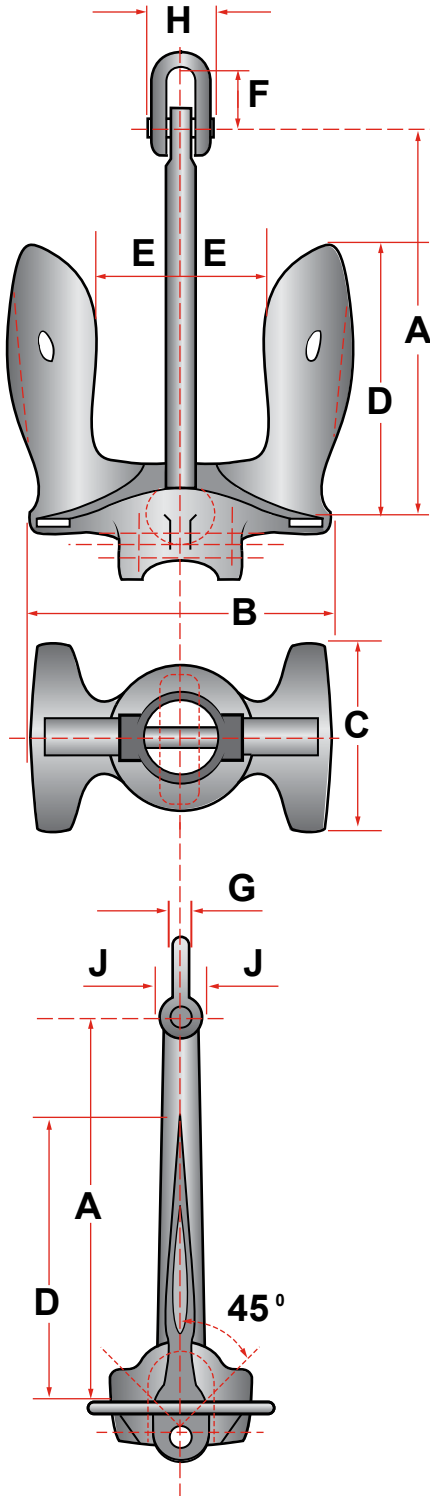

ANCHOR WT	A	B	C	D	E	F	G	H	J	PROOF TEST
300	28-5/8	22-1/8	13-3/4	20-5/16	6-7/16	6	1-1/8	4	3-1/2	11560
400	31-1/2	24-5/8	15-1/8	22-3/8	6-15/16	6-13/16	1-1/4	4-3/8	3-7/8	13520
500	34	26-1/4	16-1/4	24-3/32	7-1/2	6-5/16	1-5/16	4-11/16	4-1/8	15420
600	36	27-29/32	17-9/32	25-5/8	7-13/16	6-5/8	1-7/16	5	4-3/8	17270
800	39-11/16	30-11/16	19	28-3/16	8-3/4	7-5/16	1-9/16	5-9/16	4-7/8	20970
1000	42-3/16	33-1/8	20-1/2	30-3/8	9-13/32	7-15/16	1-11/16	6	5-1/4	24700
1200	45-3/8	35-1/8	21-3/4	32-1/4	10	8-3/16	1-7/8	6-3/8	5-1/2	28360
1300	46-5/8	36	22-3/8	33-1/8	10-9/32	8-11/16	1-3/4	6-3/8	5-11/16	30210
1500	49	37-7/8	23-1/2	34-3/4	10-3/4	9	2	6-7/8	6	33810
1800	52	40-1/4	24-15/16	36-15/16	11-7/16	9-9/16	2-1/16	7-5/16	6-3/8	39000
2000	54	41-11/16	25-13/16	38-1/4	11-7/8	9-15/16	2-1/8	7-9/16	6-1/2	42450
2200	54-5/8	43	26-5/8	39-1/2	12-1/4	10-1/4	2-3/16	7-13/16	6-3/4	45730
2500	58	44-7/8	27-13/16	41-1/4	12-3/4	10-3/4	2-1/4	8-3/16	7-3/16	50660
3000	63-1/2	50	30-1/2	44-1/2	13-7/8	11-1/4	2-3/8	8-1/2	7-1/2	58720
3500	64-7/8	50-1/8	31-1/16	46-3/32	14-9/32	12	2-1/2	8-15/16	7-7/8	66220
4000	67-7/8	52-1/2	32-9/16	48-7/32	14-15/16	12-1/2	2-11/16	9-9/16	8-13/16	73720
5000	73	56-9/16	35	51-15/16	16-1/16	13-1/2	2-7/8	10-1/4	9-1/8	87360
6000	77-3/4	60-3/16	37-5/16	55-1/4	17-1/8	14-5/16	3-1/16	10-15/16	9-5/8	99760
7000	82	63-1/4	39-1/4	58-1/16	18-1/32	15-1/8	3-3/16	11-1/2	9-15/16	111440
8000	85-1/2	66-1/4	41	60-3/4	18-7/8	15-3/4	3-3/8	12	10-3/8	121830
9000	88-7/8	68-3/4	42-5/8	63-1/8	19-5/8	16-3/8	3-1/2	12-1/2	10-13/16	131480
10000	92	71-1/4	44-1/8	65-3/8	20-5/16	17	3-5/8	12-15/16	13-3/16	140830
11000	95	73-9/16	45-5/8	67-1/2	20-29/32	17-1/2	3-3/4	13-3/8	11-3/4	149100
12000	97-7/8	75-3/4	47	69-1/2	21-19/32	18	3-7/8	13-3/4	11-7/8	156600
13000	100	77-3/8	46-5/8	71-1/16	22	18-3/8	3-15/16	14-1/8	12-5/16	164100
14500	104	80-5/8	50	74	22-9/16	19-3/16	4-1/8	14-5/8	12-7/8	174100
15000	105-1/2	82-1/4	51	73-1/4	23-1/8	19-5/8	4-1/4	15	13	177220
16000	107-11/16	83-11/32	51-5/8	76-1/2	23-23/32	19-7/8	4-1/4	15-1/8	13-1/4	183500
18000	112	86-5/8	53-3/4	79-9/16	24-5/8	20-5/8	4-3/8	15-3/4	13-13/16	194720
20000	116	89-3/4	55-5/8	82-7/16	25-1/2	21-7/16	4-1/2	16-1/4	14-5/16	204720
22500	120-1/2	93-5/16	57-13/16	85-11/16	26-17/32	22-1/4	4-3/4	17	14-7/8	217000
25000	125	96-11/16	59-15/16	88-13/16	27-1/2	22-15/16	5	17-9/16	15-7/16	232100
30000	132-3/4	102-11/16	63-5/8	94-1/4	29-7/32	24-7/16	5-1/4	18-11/16	16-3/8	252800
35000	139-3/4	108	67-1/16	99-5/16	30-3/4	25-3/4	5-1/2	19-11/16	17-1/4	269900
40000	146	113-1/6	70	103-1/8	32-1/4	27-1/8	5-5/8	20-1/2	17-3/4	284300
45000	152	117-5/8	72-7/8	108	33-7/16	28	6	21-3/8	18-3/4	296400
60000	188	125-3/4	87-5/16	132-7/8	38-11/16	29	7-1/2	24-1/2	20-1/2	372700

Intermediate sizes available upon request.
 Dimensions above are in inches, anchor weight in pounds.
 Certified drawings of anchors, listed above, and of intermediate and larger sizes may be furnished on request.

AC-14 HIGH HOLDING POWER

APPROX. WEIGHTS AND DIMENSIONS

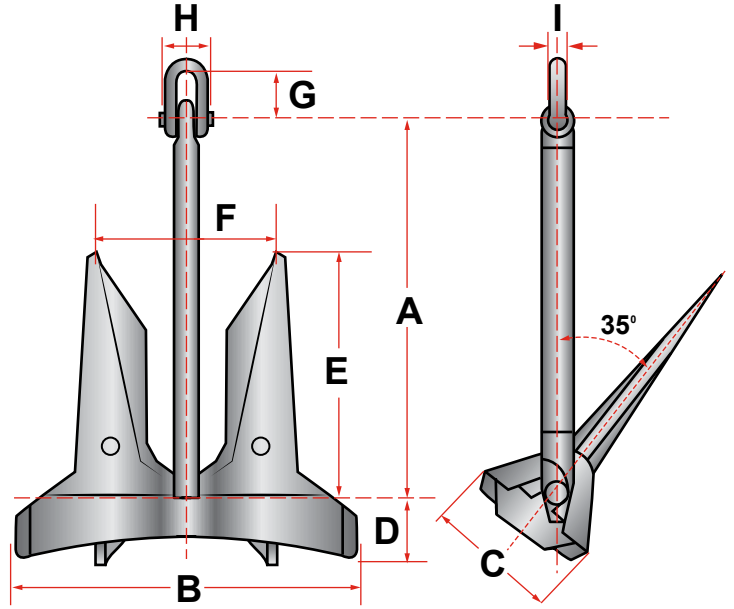

WEIGHT KG	DIMENSIONS IN MM								
	A	B	C	D	E	F	G	H	I
180	904	811	251	157	550	434	138	135	36
225	974	874	270	169	593	468	149	145	39
340	1109	995	307	192	675	533	169	165	45
460	1227	1101	340	212	747	590	187	182	49
675	1398	1254	389	242	851	672	213	207	56
910	1540	1382	427	267	938	740	235	229	62
1140	1660	1490	460	287	1011	798	253	246	67
1360	1761	1580	488	305	1072	846	269	261	71
1590	1855	1665	514	321	1130	892	283	275	75
1820	1940	1741	538	336	1182	933	296	288	78
2440	2016	1809	559	349	1227	969	308	299	81
2270	2089	1874	579	362	1272	1004	319	310	84
2720	2218	1991	615	384	1351	1066	339	329	90
3040	2302	2066	638	399	1402	1107	351	342	93
3240	2352	2110	652	407	1432	1130	359	349	95
3445	2400	2154	665	415	1462	1154	366	356	97
3670	2451	2200	680	424	1493	1178	374	364	99
3940	2510	2252	696	434	1529	1207	383	373	101
4210	2566	2303	711	444	1563	1234	392	381	104
4500	2624	2355	727	454	1598	1261	401	389	106
4840	2688	2412	745	465	1637	1292	410	399	108
5175	2749	2467	762	476	1674	1321	420	408	111
5515	2808	2520	778	486	1710	1350	429	417	113
5850	2864	2570	794	496	1744	1376	437	425	116
6225	2923	2623	810	506	1780	1405	446	434	118
6525	2970	2665	823	514	1808	1428	453	441	120
6600	2981	2675	826	516	1815	1433	455	443	120
7015	3042	2730	843	527	1853	1462	464	452	123

WEIGHT KG	DIMENSIONS IN MM								
	A	B	C	D	E	F	G	H	I
7425	3100	2782	859	537	1888	1490	473	460	125
7875	3162	2837	876	547	1925	1520	483	469	128
8325	3221	2890	893	558	1961	1548	492	478	130
8775	3278	2942	909	567	1996	1576	500	487	132
9225	3333	2991	924	577	2030	1602	509	495	134
9675	3386	3039	939	586	2062	1628	517	503	137
10125	3438	3085	953	595	2094	1653	525	511	139
10575	3488	3130	967	604	2124	1677	533	518	141
10690	3501	3141	970	606	2132	1683	535	519	141
11025	3537	3174	981	612	2154	1700	540	525	143
11250	3561	3196	987	616	2169	1712	544	529	144
11550	3592	3224	996	622	2188	1727	548	533	145
11850	3623	3251	1004	627	2206	1742	553	537	146
12075	3646	3272	1011	631	2220	1753	557	541	147
12525	3691	3312	1023	639	2248	1774	563	548	149
12675	3705	3325	1027	641	2256	1781	566	550	150
13200	3756	3370	1041	650	2287	1805	573	558	152
13350	3770	3383	1045	653	2296	1812	576	560	152
13875	3819	3426	1059	661	2326	1836	583	567	154
14100	3839	3445	1064	665	2338	1846	586	570	155
15000	3919	3517	1086	678	2387	1884	599	582	158
16125	4015	3603	1113	695	2445	1930	613	596	162
17250	4106	3685	1138	711	2501	1974	627	610	166
18375	4194	3763	1163	726	2554	2016	640	623	169
19500	4278	3839	1186	740	2605	2056	653	635	173
20625	4358	3811	1208	754	2654	2095	665	647	176
21750	4436	3980	1230	768	2701	2132	677	659	179

DELTA TYPE ANCHOR

SUPERIOR HOLDING POWER

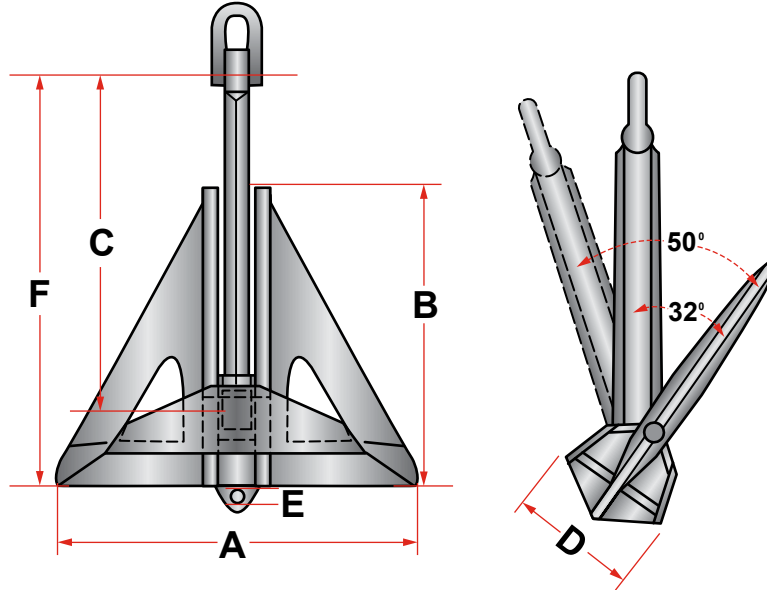

APPROXIMATE WEIGHTS AND DIMENSIONS

ANCHOR WT IN KG	DIMENSIONS IN MM							
	A	B	C	D	E	F	SHACKLE DIA.	EYE
1000	1960	1560	1755	740	45	2605	52	50
1500	2250	1800	2025	840	45	2660	60	50
2000	2470	2000	2250	930	50	2960	70	60
2500	2660	2130	2395	1005	52	3150	70	60
3000	2830	2285	2565	1070	55	3380	80	60
3500	3000	2400	2700	1120	55	3550	80	70
4000	3180	2560	2880	1190	65	3790	90	60
5000	3300	2660	2995	1260	75	3945	100	70
6000	3560	2870	3230	1345	75	4250	100	80
7000	3750	2995	3365	1405	78	4440	110	90
7500	3850	3080	3465	1435	85	4565	110	90
9000	4130	3320	3735	1550	85	4925	125	100
10000	4270	3400	3825	1600	85	5040	125	100
12000	4530	3600	4050	1705	90	5335	130	110
13500	4670	3730	4195	1765	90	5535	140	110
15000	4845	3875	4355	1830	90	5735	140	120
18000	5265	4120	4635	1935	105	6110	150	120
20000	5410	4320	4860	2010	105	6405	160	130
22500	5490	4360	4905	2060	105	6470	170	140
27500	5980	4785	5385	2245	120	7095	180	140
32500	6200	4930	5540	2310	120	7320	165GP	150
40000	6650	5290	5945	2480	120	7850	175GP	150
50000	7150	5690	6390	2670	130	8440	195GP	180
60000	7600	6040	6800	2830	140	9000	210GP	190
75000	8200	6560	7380	3100	150	9430	220GP	220

MOORFAST ANCHOR

ANCHOR WT	A	B	C	D	E	F	PROOF TEST
1000	61	75	37	25	19	2	30000
3000	88	109	54	37	27	3	72500
6000	101	143	61	42	31	3-1/2	121300
8000	122	153	75	51	38	3-1/2	145000
10000	131	157	80	55	41	4	165600
12000	139	167	85	58	43	4	184700
14000	147	177	90	61	45	4	205000
16000	153	187	94	64	48	4-1/2	222700
20000	164	196	102	69	51	4-1/2	249400
30000	189	217	118	79	59	5	319400
40000	215	248	127	86	63	5-1/2	386000
50000	222	257	132	89	66	6	448300
60000	232	271	140	95	70	6	506200
70000	244	274	147	100	73	6	561400
80000	255	298	154	105	77	6-1/2	613300
90000	266	310	160	109	80	6-1/2	661200
100000	275	320	166	113	83	7	706400

All specifications in pounds and inches.
Intermediate sizes may be furnished on request.

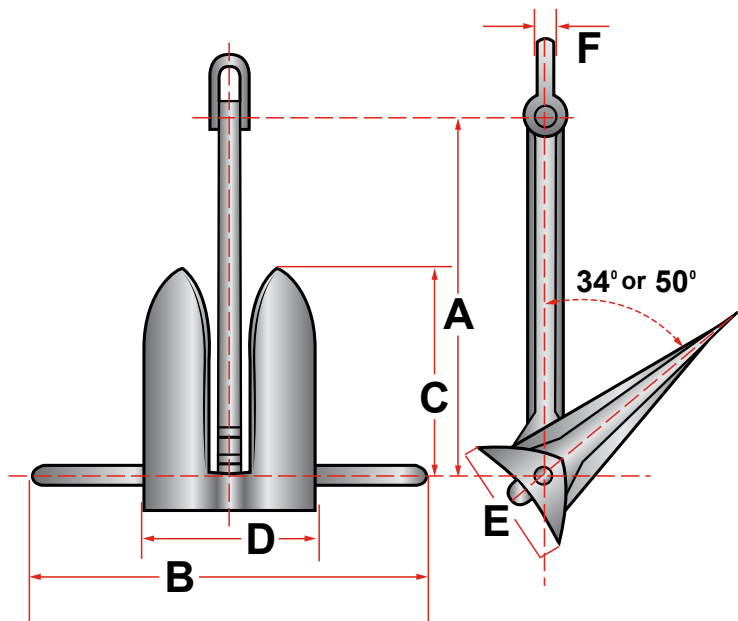

SNUG STOWING ANCHOR

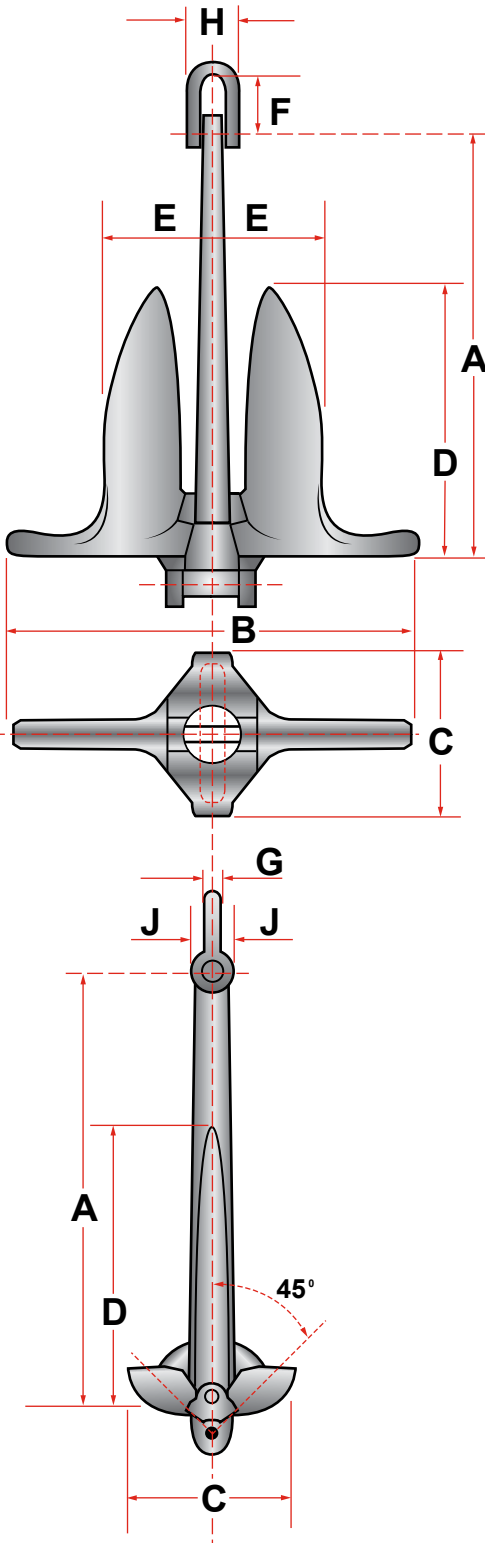

ANCHOR WT	A	B	C	D	E	F	G	H	J	PROOF TEST
200	30-7/8	29-11/16	12-1/16	20-1/8	16-3/16	3-3/4	1	3-11/16	2-3/4	10100
250	33-5/16	32	13	21-11/16	17-7/16	3-3/4	1	3-11/16	3	11600
300	35-3/16	34	13-3/4	23	18-1/2	3-3/4	1	3-11/16	3-1/8	13000
350	37-3/16	35-3/4	14-1/2	24-1/4	19-1/2	3-3/4	1	3-11/16	3-3/8	14300
400	38-7/8	37-3/8	15-1/4	25-3/8	20-3/8	3-3/4	1	3-11/16	3-1/2	15600
450	40-3/8	38-7/8	15-3/4	26-3/8	21-1/8	3-3/4	1	3-11/16	3-5/8	16900
500	41-3/4	40-1/4	16-3/8	27-1/4	21-7/8	4-5/8	1-1/4	4-17/32	3-3/4	18100
750	48	46	18-3/4	31-1/4	25-1/8	4-5/8	1-1/4	5-3/8	4-3/8	24100
1000	52-3/4	50-3/4	20-5/8	34-3/8	27-5/8	5-11/16	1-1/2	5-3/8	4-3/4	30000
2000	66-1/2	64	26	43-1/4	34-7/8	7-7/8	2	7-1/4	6	52300
3000	76	73	29-5/8	49-1/2	39-3/4	9-3/8	2-1/2	9-1/8	6-7/8	72500
4000	83-3/4	80-1/2	32-3/4	54-1/2	43-7/8	9-3/8	2-1/2	9-1/8	7-1/2	90700
5000	90-3/8	86-3/4	35-1/4	58-3/4	47-1/4	10-1/8	3	11	8-1/8	107000
6000	96	92-1/8	37-1/2	62-1/2	50-1/4	10-1/8	3	11	8-3/8	121300
7000	101	97	39-1/2	65-3/4	52-7/8	10-1/8	3	11	9-1/8	134300
8000	105-3/4	101-1/2	41-1/4	68	55-3/8	10-1/8	3	11	9-1/2	145600
9000	110	105-1/2	43	71-1/2	57-1/2	12-3/8	3-1/2	12-1/4	10	155600
10000	113-3/4	109-1/4	44-1/2	74	59-1/2	12-3/8	3-1/2	12-1/4	10-1/4	165600
11000	117-1/2	112-7/8	45-3/4	76-1/2	61-1/2	19	4	13-3/4	10-1/2	174600
12000	120-3/4	116	47-1/8	78-5/8	63-1/4	19	4	13-3/4	10-1/8	184700
13000	124	119-1/8	48-3/8	80-3/4	64-7/8	19	4	13-3/4	11-1/8	194300
14000	127-1/4	122-1/4	49-5/8	82-3/4	66-5/8	19	4	13-3/4	11-1/2	205000
15000	130	125	50-3/4	84-5/8	68	19	4	13-3/4	11-3/4	213700
16000	133-1/4	128	52	86-3/4	69-3/4	19	4	13-3/4	12	222700
17000	136	130-1/2	53-1/8	88-1/2	71-1/8	19	4-1/2	13-3/4	12-1/4	230000
18000	138-3/4	133-1/8	54-1/8	90-1/4	72-1/2	22	4-1/2	15-3/4	12-1/2	238000
19000	141	135-1/2	55	91-7/8	73-7/8	22	4-1/2	15-3/4	12-3/4	244100
20000	143-1/4	137-5/8	56	93-1/4	75	22	4-1/2	15-3/4	12-7/8	249400
25000	154	148	60-1/4	100-1/2	80-3/4	22	4-1/2	15-3/4	13-7/8	282500
30000	164	157-1/2	64-1/8	106-3/4	86	24	5	17-3/4	14-3/4	319400
40000	180	173	70	117	94	26	5-1/2	19	16	386400
50000	195	187	76	126	102	28	6	20	18	448300
60000	206	197	80	134	108	30	6	22	19	506200
70000	218	208	85	140	113	32	6-1/2	23	20	561400
80000	227	218	89	146	120	33	6-1/2	24	21	613400
90000	236	226	92	153	126	35	7	26	22	690000
100000	244	234	95	158	130	36	7	27	23	767000

All specifications in pounds and inches.
Intermediate sizes may be furnished on request.

STATO MOORING ANCHOR

ANCHOR WT	A	B	C	D
200	42	59	26	3/4
3000	129	109	72	1-3/4
6000	144	143	92	2-1/4
9000	160	170	100	2-3/4
12000	186	197	113	3
15000	204	224	126	3-1/2
20000	210	230	129	3-3/4
25000	226	246	137	4
30000	235	257	145	5
35000	248	271	153	5-1/4
40000	258	283	160	5-1/2
45000	269	295	166	5-3/4
50000	277	303	171	6

All specifications in pounds and inches.
Intermediate sizes may be furnished on request.

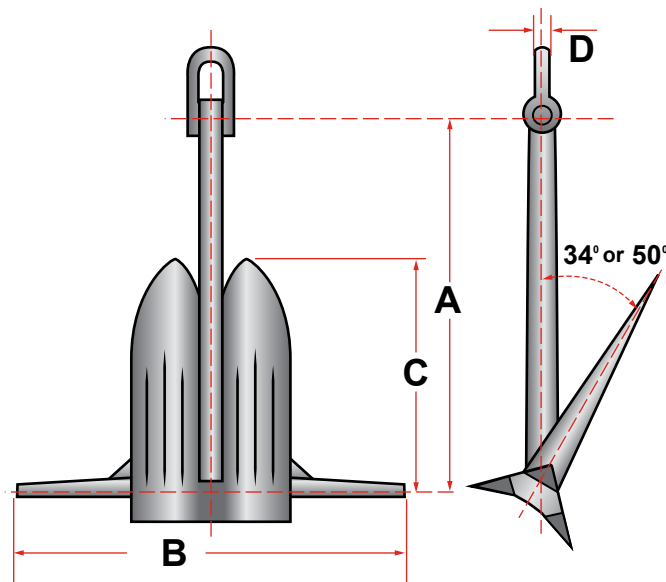

OFFDRILL ANCHOR

HIGH HOLDING POWER

APPROX. WEIGHTS AND DIMENSIONS

ANCHOR WEIGHT KG	DIMENSIONS IN MM					
	A	B	C	D	E	G
454	1545	1900	920	1095	480	645
1360	2230	2770	1330	1580	690	930
2721	2570	3630	1530	1820	795	1071
3628	3095	3890	1840	2190	960	1290
4535	3335	4000	1985	2360	1032	1390
5443	3540	4250	2110	2505	1095	1475
6350	3730	4500	2220	2640	1155	1555
7256	3900	4750	2320	2760	1205	1625
9080	4200	5000	2500	2975	1300	1750
13606	4810	5335	2860	3405	1490	2005

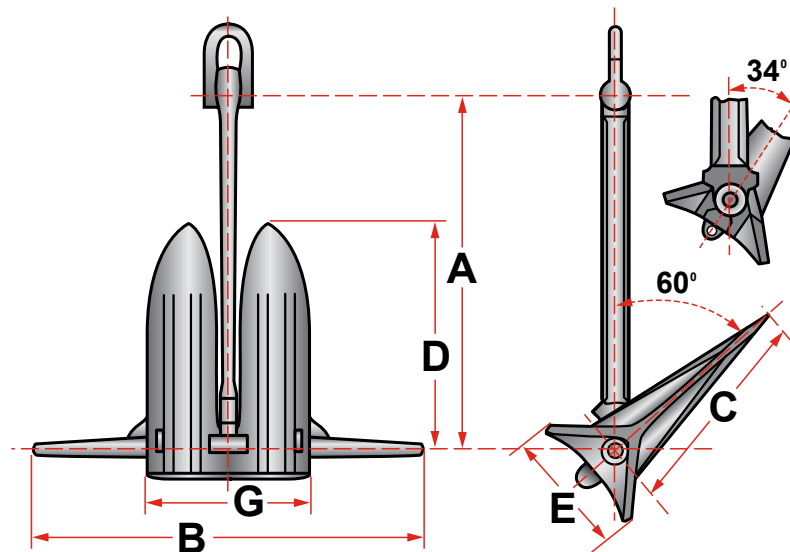

HALL ANCHOR

WEIGHT KG	A MM	B MM	C MM	D MM
50	575	410	184	300
75	660	480	210	340
100	723	510	230	375
125	780	550	245	405
150	835	580	264	430
180	888	625	281	454
200	915	645	290	470
225	950	670	300	493
240	985	694	312	510
275	1020	710	322	527
300	1050	738	330	543
325	1075	758	338	557
360	1190	778	346	570
400	1150	810	360	595
420	1175	826	368	607
450	1200	845	373	620
480	1220	860	380	630
500	1240	875	386	640
570	1280	904	400	660
600	1320	930	410	680
660	1360	955	420	700
700	1390	980	430	715
750	1425	1000	440	730
780	1450	1030	450	750
850	1480	1050	460	765
900	1490	1053	480	772
950	1520	1072	484	787
1020	1545	1090	496	800
1140	1600	1126	512	825
1200	1650	1165	530	855
1290	1670	1180	535	865
1350	1700	1205	550	890
1440	1800	1245	555	895
1590	1890	1260	565	900
1740	1910	1290	582	945
1920	1930	1362	616	999
2100	2020	1407	623	1020
2280	2040	1446	640	1033
2460	2120	1483	667	1076
2640	2170	1519	672	1085
2850	2200	1540	700	1140

WEIGHT KG	A MM	B MM	C MM	D MM
3060	2261	1596	720	1172
3300	2330	1636	734	1180
3540	2336	1650	674	1210
3780	2679	1844	733	1295
4050	2466	1740	712	1278
4320	2667	1790	763	1290
4590	2784	1889	780	1384
4890	2923	2011	804	1413
5250	2728	1910	846	1364
5510	2788	1952	864	1394
6000	3270	2033	829	1525
6450	2920	2048	906	1461
6900	2930	2064	932	1512
7350	3072	2150	950	1536
7800	3113	2179	965	1556
8300	3208	2246	995	1604
8700	3253	2270	1005	1626
8900	3268	2275	1012	1634
9300	3301	2311	1023	1650
9900	3330	2360	1045	1686
10200	3338	2372	1070	1694
10500	3438	2407	1075	1719
11100	3502	2452	1086	1751
11700	3565	2495	1105	1780
12300	3600	2520	1140	1800
12900	3681	2577	1141	1840
13500	3738	2616	1159	1869
14100	3793	2655	1176	1896
14700	3845	2690	1190	1925
15400	3880	2716	1210	1940
16100	3964	2775	1229	1982
16900	4030	2820	1250	2015
17800	4099	2869	1270	2049
18800	4175	2920	1295	2085
20000	4262	2985	1320	2130
21500	4365	3055	1355	2180
23000	4465	3125	1385	2230
24500	4560	3190	1415	2280
26000	4651	3255	1442	2325
27500	4720	3315	1470	2370
29000	4825	3375	1495	2410

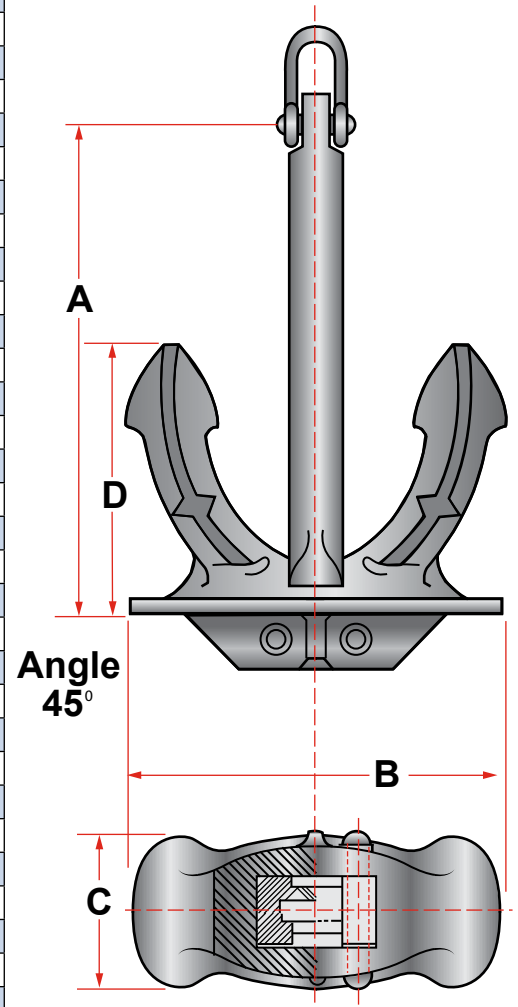

POOL "N" TYPE ANCHOR

HIGH HOLDING POWER

TABLE OF MAIN DIMENSIONS IN MM

WEIGHT KG	A	B	C	D	E	F	G
4	224	190	198	106	265	41	23
8	282	239	250	133	334	62	37
12	323	274	286	153	382	80	50
16	355	302	315	168	421	80	50
20	383	325	339	181	453	90	60
24	407	346	361	193	482	90	60
32	448	380	397	212	530	100	80
40	482	410	427	228	571	100	80
48	512	435	454	243	607	120	90
60	560	475	490	262	654	120	90
75	595	505	526	282	704	120	90
90	632	537	559	299	748	120	90
105	665	565	588	315	788	142	105
125	703	597	622	333	833	142	105
135	723	615	640	343	857	142	105
180	796	676	706	377	942	157	115
225	858	728	760	406	1016	170	125
270	911	774	807	432	1079	186	135
315	960	815	850	455	1136	201	150
360	1002	852	888	475	1188	201	150
430	1062	902	940	503	1258	236	175
495	1115	948	988	528	1320	236	175
585	1180	1002	1045	558	1396	284	185
675	1236	1050	1096	586	1465	284	185
765	1290	1096	1144	610	1527	284	185
855	1338	1138	1185	634	1585	306	225
970	1395	1185	1236	660	1652	306	225
1080	1446	1230	1282	685	1714	306	225
1195	1495	1270	1323	708	1771	306	225
1305	1541	1309	1364	730	1825	306	225
1440	1592	1352	1412	754	1886	306	225
1575	1640	1386	1454	777	1942	361	255
1710	1686	1433	1492	799	1997	361	255
1845	1729	1469	1530	819	2048	361	255
1980	1770	1504	1570	838	2098	361	255
2140	1816	1543	1608	860	2151	361	255
2295	1860	1580	1650	880	2202	361	255
2475	1910	1620	1690	904	2260	400	290
2655	1954	1664	1730	925	2312	400	290
2835	1996	1700	1770	945	2364	400	290
3040	2042	1735	1810	968	2418	400	290
3240	2086	1773	1850	988	2471	400	290
3445	2129	1809	1887	1009	2522	400	290
3670	2174	1847	1928	1030	2575	450	325
3940	2226	1892	1970	1055	2637	450	325
4210	2276	1934	2018	1078	2696	450	325
4500	2328	1978	2064	1103	2757	450	325
4840	2385	2026	2114	1130	2824	500	360
5175	2439	2072	2162	1155	2889	500	360
5515	2491	2116	2208	1180	2950	500	360
5850	2541	2159	2252	1204	3009	550	400
6225	2594	2204	2299	1229	3072	550	400
6525	2635	2239	2336	1248	3121	550	400

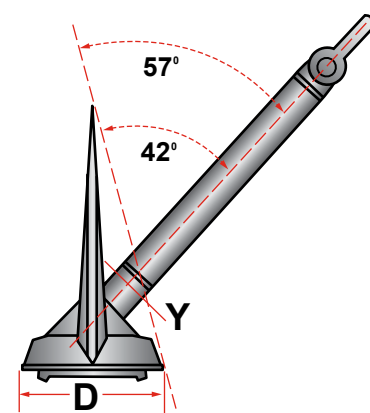
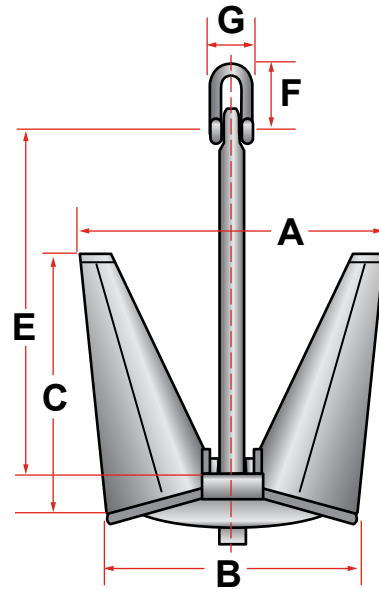

WEIGHT KG	A	B	C	D	E	F	G
6975	2695	2290	2390	1276	3190	550	400
7425	2750	2338	2439	1303	3258	600	435
7875	2805	2384	2487	1329	3323	600	435
8325	2858	2428	2533	1354	3385	650	470
8775	2908	2471	2578	1378	3445	650	470
9225	2958	2512	2622	1401	3502	650	470
9675	3004	2553	2664	1423	3558	700	500
10125	3050	2592	2704	1445	3613	700	500
10575	3095	2630	2747	1466	3666	700	500
12075	3235	2748	2868	1533	3831	750	540
14100	3406	2894	3020	1614	4034	800	570
17250	3643	3095	3230	1726	4315	870	625
20625	3867	3285	3428	1832	4580	930	665
24750	4109	3491	3643	1947	4867	930	665
28875	4324	3675	3838	2049	5123	980	695
34500	4590	3890	4070	2175	5437	1000	715

POOL "T.W." TYPE ANCHOR

HIGH HOLDING POWER

TABLE OF MAIN DIMENSIONS

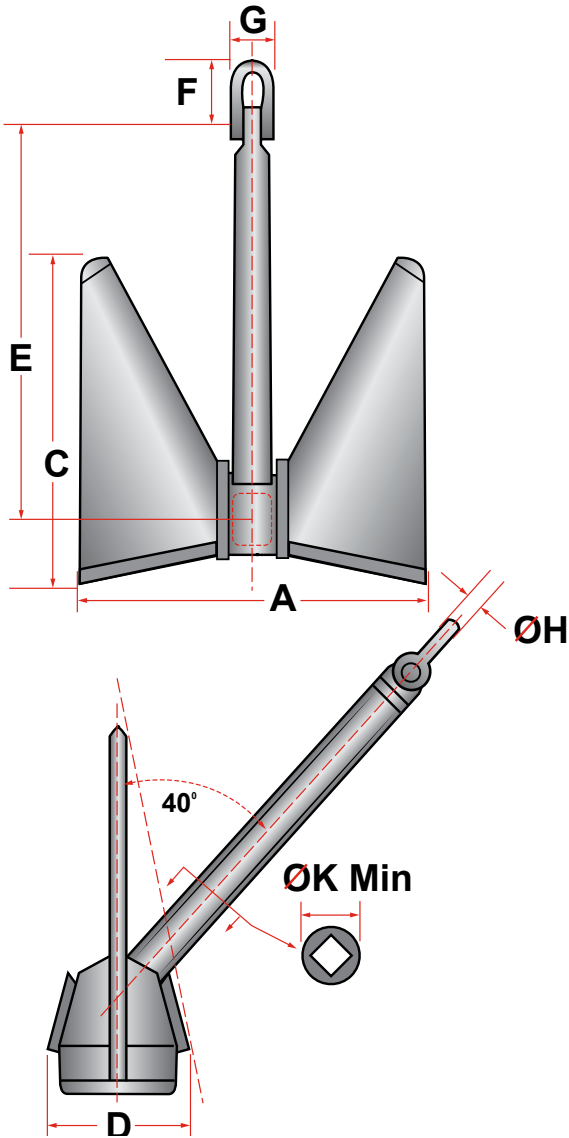

WEIGHT KG	MAIN DIMENSIONS IN MM							
	A	C	D	E	F	G	ØH	ØK
90	616	627	223	744	120	90	22	100
105	648	660	235	781	142	105	26	110
125	687	700	249	830	142	105	26	110
135	705	718	255	852	142	105	26	110
180	776	790	281	937	157	115	29	125
225	836	852	303	1010	170	125	32	135
270	888	905	322	1073	186	135	35	140
315	935	953	339	1129	201	150	38	155
360	977	996	354	1181	201	150	38	155
430	1037	1056	376	1253	236	175	45	180
495	1087	1107	394	1313	236	175	45	180
585	1149	1171	417	1318	284	185	47	190
675	1205	1228	437	1456	284	185	47	190
765	1257	1280	455	1518	284	185	47	195
855	1304	1329	473	1576	306	225	60	230
970	1360	1386	493	1643	306	225	60	230
1080	1409	1436	511	1703	306	225	60	230
1195	1458	1486	528	1762	306	225	60	235
1305	1501	1500	544	1814	306	225	60	235
1440	1552	1581	562	1875	306	225	60	245
1575	1599	1629	579	1931	361	255	70	260
1710	1643	1674	596	1985	361	255	70	260
1845	1685	1717	611	2036	361	255	70	260
1980	1725	1758	625	2084	361	255	70	275
2140	1771	1805	642	2139	361	255	70	280
2295	1812	1847	657	2190	361	255	70	290
2475	1858	1894	674	2245	400	290	80	295
2655	1903	1939	690	2299	400	290	80	305
2835	1945	1981	705	2349	400	290	80	305
3040	1990	2028	721	2405	400	290	80	315
3240	2033	2072	737	2456	400	290	80	315
3445	2075	2114	752	2507	400	290	80	325
3670	2119	2159	769	2560	450	325	90	330
3948	2170	2211	787	2622	450	325	90	340
4210	2219	2261	804	2680	450	325	90	345

SPEK ANCHOR

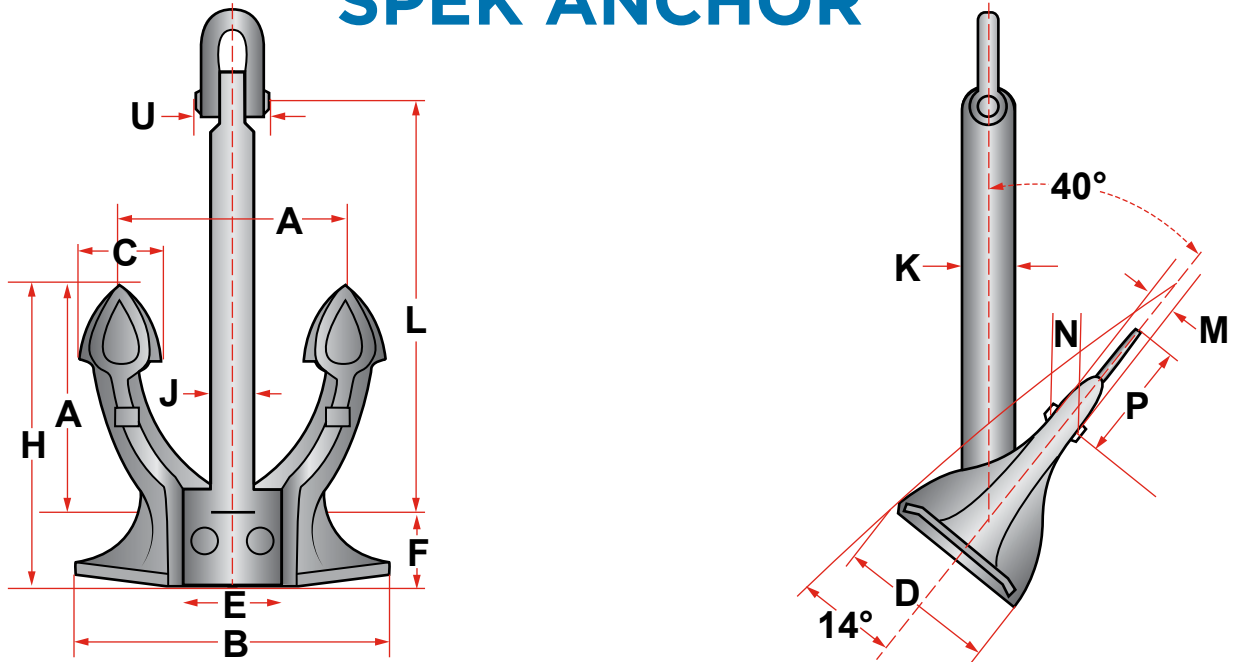

TABLE OF MAIN DIMENSIONS

WEIGHT	A	B	C	D	E	F	H	J	K	L	M	N	P
240 - 310	500	690	160	342	220	150	650	100	120	900	26	54	270
310 - 380	550	760	175	390	228	166	716	110	130	990	28	63	300
380 - 480	600	827	190	412	258	180	780	120	135	1080	23	69	320
480 - 610	650	908	205	442	280	196	846	130	160	1170	31	74	350
610 - 735	700	960	221	472	302	210	910	140	170	1260	33	86	375
735 - 880	750	1030	235	502	320	225	975	150	185	1350	34	77	400
880 - 1030	800	1100	251	542	340	240	1040	160	195	1440	38	80	430
1030 - 1150	850	1170	270	568	362	252	1102	170	200	1530	31	76	460
1150 - 1400	900	1240	286	587	328	268	1168	180	210	1620	38	87	485
1400 - 1750	950	1299	295	644	420	279	1229	190	220	1710	44	99	510
1750 - 2020	1000	1378	316	671	442	300	1300	200	235	1800	52	107	540
2020 - 2360	1050	1454	330	706	460	312	1362	210	240	1890	52	123	565
2360 - 2750	1100	1514	343	744	480	324	1424	220	265	1980	52	133	590
2750 - 3000	1150	1584	362	788	492	352	1502	230	285	2070	68	141	620
3000 - 3700	1200	1650	380	801	520	360	1560	245	300	2160	58	138	645
3700 - 4000	1350	1850	418	890	580	393	1743	265	330	2430	58	138	720
4000 - 5100	1400	1927	438	910	610	413	1813	280	340	2520	68	142	750
5100 - 5800	1450	2000	451	954	626	414	1864	290	345	2610	65	161	780
5800 - 6600	1500	2060	467	998	642	446	1946	300	355	2700	65	160	810
6600 - 8000	1550	2138	490	1030	660	456	2006	310	370	2790	64	169	835
8000 - 9600	1700	2333	533	1118	734	510	2210	330	410	3060	67	175	920
9600 - 11700	1770	2440	559	1178	782	531	2301	350	435	3186	83	180	955
11700 - 14100	1910	2632	603	1270	844	573	2483	380	470	3438	87	192	1030
14100 - 17000	2050	2825	648	1360	876	615	2665	410	500	3690	91	204	1105

All specifications in kilograms and millimeters. Intermediate sizes may be furnished on request.

MUSHROOM ANCHOR MOORING SIZES

WEIGHT LBS.	DIMENSIONS IN INCHES				
	BELL THICKNESS	BELL DIAM.	SHANK DIAM.	EYE DIAM.	OVERALL LENGTH
50	1/4	20	1-1/4	7/8	34
100	1/2	25-1/2	1-1/4	1	48
150 S.	1	26	1-1/2	1	24
150 L.	1/2	29-1/2	1-1/2	1	52
200	5/8	32	1-1/2	1-1/8	56
250	3/4	34-1/2	2-1/4	1-1/4	64
300	3/4	34-1/2	2-1/4	1-1/4	64
350	3/4	37	2-1/4	1-1/4	70

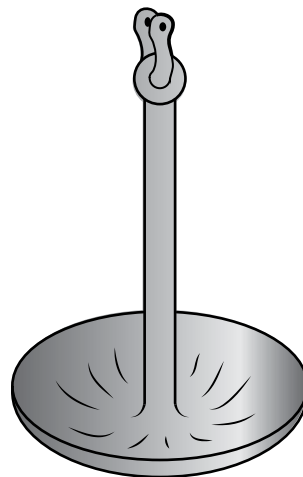

ADMIRALTY STYLE (KEDGE) ANCHOR

ANCHOR WT	WEIGHT N-STOCK	A	B	C	D	F	H	G	PROOF TEST
100	81	36	27	9	6	5	5	1	6850
150	119	41	31	11	8	5	5	1	7686
200	156	45	34	12	8	5	5	1	8500
250	199	49	38	13	9	7	6	1	9334
300	236	51	40	14	10	7	6	1	10090
350	274	54	42	15	10	7	6	1	10834
400	316	56	43	15	11	7	6	1	11560
450	354	58	45	16	11	7	6	1	12305
500	391	60	56	17	11	7	6	1	13030
550	429	63	49	17	12	7	6	1	13767
600	466	64	50	17	12	7	6	1	14500
650	504	66	52	18	13	7	6	1	15192
700	554	68	53	18	13	8	7	1	15885
750	592	71	54	19	13	8	7	1	16585
800	629	71	55	19	13	8	7	1	17270
850	667	73	57	20	14	8	7	1	17973
900	704	74	58	20	14	8	7	1	18660
950	742	76	59	21	14	8	7	1	19360
1000	779	77	60	21	15	8	7	1	20050
1050	831	78	61	21	15	8	8	2	20748
1100	868	79	61	21	15	9	8	2	21430
1150	906	80	62	22	15	9	8	2	22135
1200	943	81	63	22	15	9	8	2	22820
1250	981	83	64	23	16	9	8	2	23523
1300	1018	84	65	23	16	9	8	2	24205
1350	1056	85	66	23	16	9	8	2	24910
1400	1093	85	66	23	16	9	8	2	25590
1500	1168	88	68	24	17	9	8	2	26980
1600	1259	89	69	24	17	11	9	2	28360
1700	1334	91	71	25	17	11	9	2	29750
1800	1409	93	72	25	18	11	9	2	31140
1900	1484	94	73	26	18	11	9	2	32500
2000	1559	97	75	26	18	11	9	2	33810
2100	1634	98	76	27	19	11	9	2	35125
2200	1728	99	77	27	19	12	10	2	36440
2300	1803	101	78	27	19	12	10	2	37750
2400	1878	102	79	28	20	12	10	2	39080
2500	1953	103	81	28	20	12	10	2	40375
2600	2028	103	81	29	20	12	10	2	41630
2700	2103	106	83	29	20	12	10	2	42860
2800	2178	107	84	29	21	12	10	2	44090
2900	2253	109	85	30	21	12	10	2	45320
3000	2386	110	86	30	21	15	12	2	46550
3250	2374	113	88	31	22	15	12	2	49643
3500	2761	116	90	32	22	15	12	3	52710
3750	2949	119	93	33	23	15	12	3	55793
4000	3136	122	95	33	23	15	12	3	58720
4250	3324	124	96	34	24	15	12	3	61540
4500	3516	127	99	35	24	15	12	3	64420

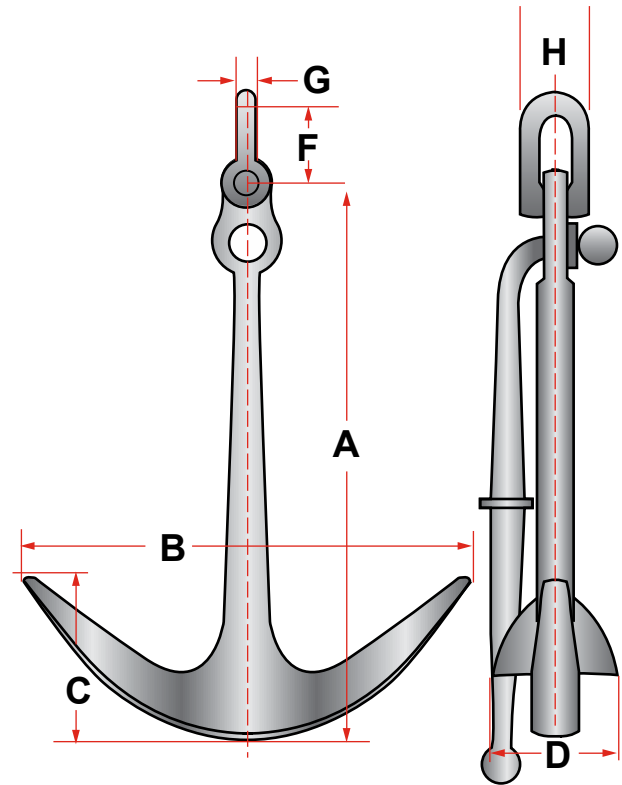

ANCHOR WT	WEIGHT N-STOCK	A	B	C	D	F	H	G	PROOF TEST
4750	3699	129	101	35	25	15	12	3	67165
5000	3886	131	102	36	25	15	12	3	69970
5250	4145	133	103	36	26	17	13	3	72790
5500	4332	135	105	37	26	17	13	3	75511
5750	4520	137	107	38	26	17	13	3	78028
6000	4707	139	109	38	27	17	13	3	80600
6250	4895	141	110	39	27	17	13	3	83164
6500	5082	143	111	39	27	17	13	3	85824
6750	5270	144	112	40	28	17	13	3	86154
7000	5457	146	114	40	28	17	13	3	90510
7250	5645	148	115	40	28	17	13	3	92879
7500	5832	150	117	41	29	17	13	3	95283
7750	6020	151	118	41	29	17	13	3	97497
8000	6207	153	119	42	29	17	13	3	99760
8250	6327	154	120	42	30	19	14	4	102033
8500	6714	156	122	43	30	19	14	4	104310
8750	6902	157	123	43	30	19	14	4	106413
9000	7089	159	124	43	31	19	14	4	108563
9250	7277	160	125	44	31	19	14	4	110727
9500	7464	162	126	44	31	19	14	4	112831
9750	7652	163	127	45	31	19	14	4	114789
10000	7839	164	128	45	32	19	14	4	116730

Intermediate sizes may be furnished on request.
Dimensions above are in inches, anchor weight in pounds.

BLOCKS



SEALINK BLOCKS

- WOOD SHELL BLOCKS FOR MANILA ROPE
- STEEL SHELL BLOCKS FOR MANILA ROPE
- WOOD SHELL SNATCH BLOCKS FOR MANILA ROPE
- STEEL SHELL SNATCH BLOCKS FOR MANILA ROPE
- STEEL SHELL SNATCH BLOCKS FOR WIRE ROPE
- CARGO HOISTING BLOCKS
- CONSTRUCTION BLOCKS
- STEEL BLOCKS FOR WIRE ROPE
- INDUSTRIAL MARINE BLOCKS



SEA-LINK®

Quality Rigging Products

TOP FITTINGS AVAILABLE ON MOST BLOCK MODELS



**FIXED HOOK WITH
SAFETY LATCH
CONNECTION - H**



**SWIVEL HOOK
WITH SAFETY LATCH
CONNECTION - SH**



**JAW SWIVEL HOOK
WITH SAFETY LATCH
CONNECTION - JSH**



**DRILLED SWIVEL EYE
CONNECTION - JSE**



**DRILLED SWIVEL
EYE AND SHACKLE
CONNECTION - JDS**



**OBLONG SWIVEL EYE
CONNECTION - JOS**



**OBLONG SWIVEL
EYE AND SHACKLE
CONNECTION - JOSS**



**JAW AND EYE SWIVEL
CONNECTION - JE**



**UPSET SCREW PIN
ANCHOR SHACKLE
CONNECTION - USPA**



**CHAIN SHACKLE
CONNECTION - SPC**



**UPSET SHACKLE
IN SHACKLE
CONNECTION - SPA-USPA**



**DRILLED SWIVEL EYE
CONNECTION - SE**



**DRILLED SWIVEL
EYE WITH SHACKLE
CONNECTION - DS**



**OBLONG SWIVEL
EYE WITH SHACKLE
CONNECTION - OSS**



**OBLONG SWIVEL EYE
CONNECTION - OS**

BLOCK REEVING

WIRE ROPE EFFICIENCY OVER SHEAVES (TACKLE BLOCK SYSTEM)

Some portion of a wire ropes strength—when operating over sheaves—is expended in turning the sheaves and in flexing. This lost strength is not available to lift the load, and in a multi-part tackle block system this loss factor can be significant.

This load on the lead line (fast line) under static (no-movement) conditions can be readily calculated if the load is divided by the number of parts of line as expressed in the following formula.

$$\text{Fast line load} = \frac{\text{Total load (incl. slings, containers, etc.)}}{\text{No. of parts of line}}$$

For example, in a four-part system to lift 6000 lb. the lead line will equal: $6000 \text{ or } \frac{1500 \text{ lb.}}{4}$

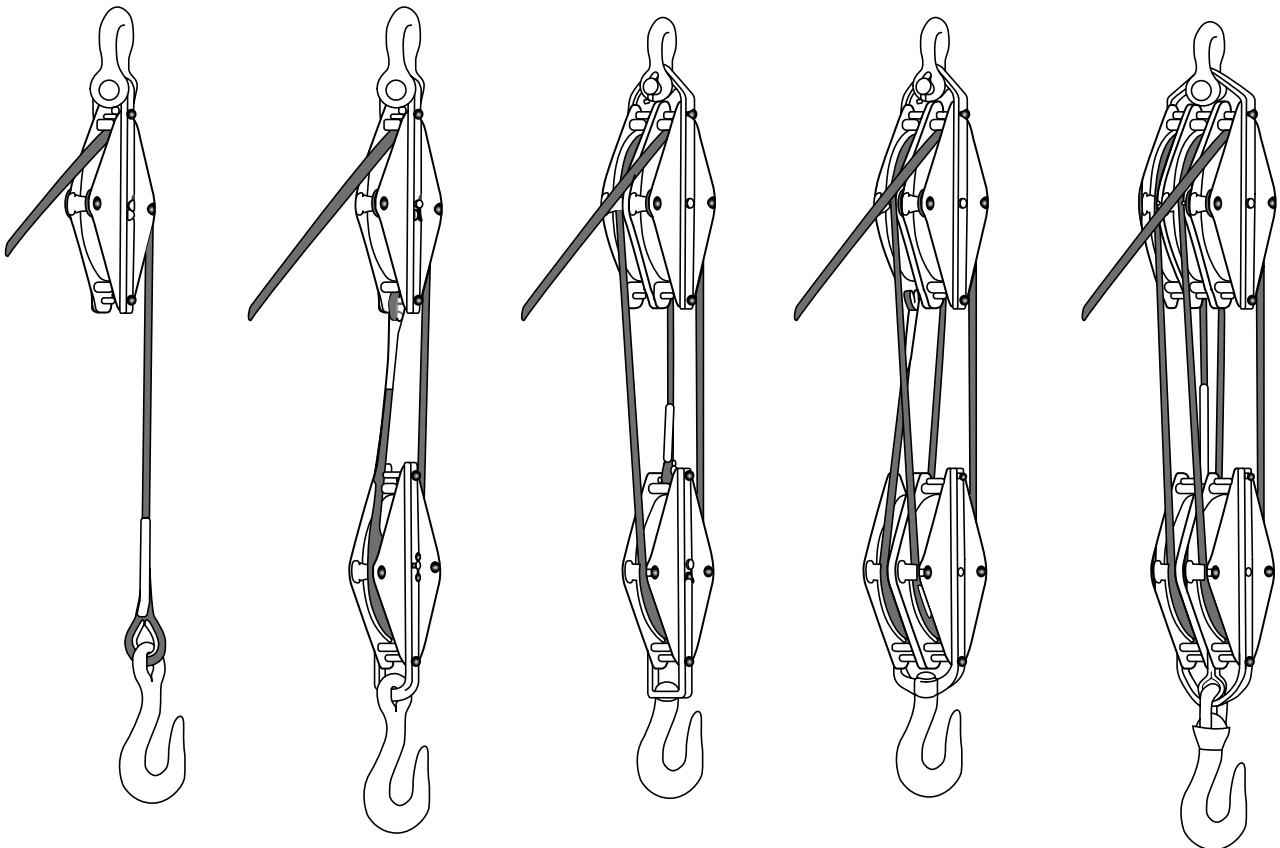

A. ONE-PART LINE

B. TWO-PART LINE

C. THREE-PART LINE

D. FOUR-PART LINE

E. FIVE-PART LINE

METHOD OF REEVING MANILA & WIRE ROPE BLOCKS

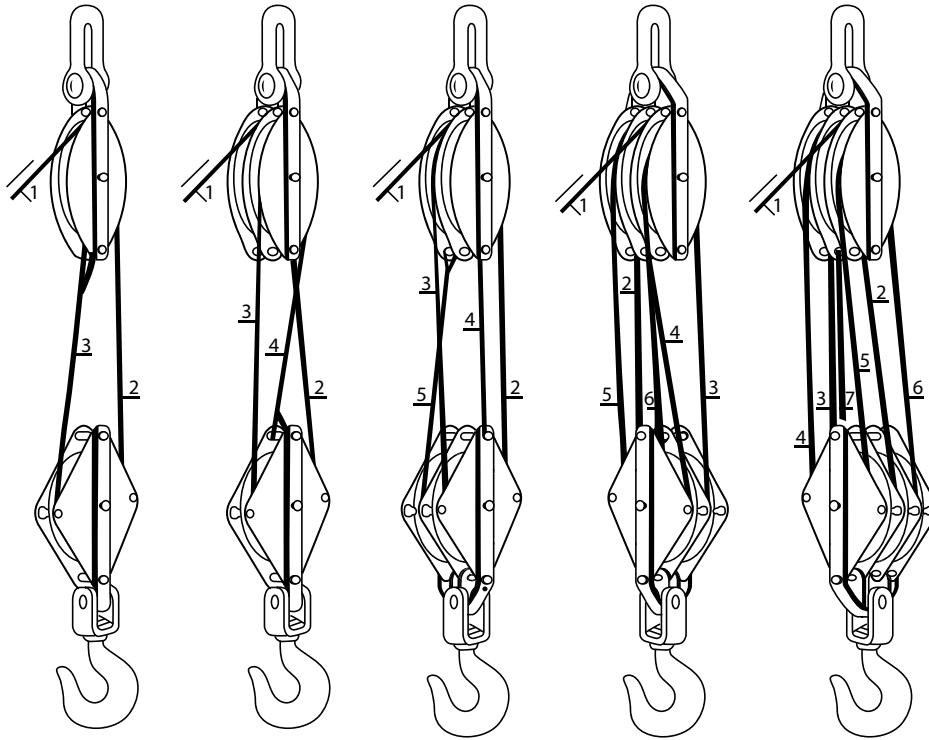

Methods of REEVING TACKLE BLOCKS vary with the application and purpose for which they are to be employed, especially on Heavy Lift Cargo Booms, Cranes, etc. where Block with 4 Sheaves or more are required, in which case a number of Lead Blocks have to be considered. We will be glad to consult with you on this matter.

PARTS OF LINE	"E" FACTORS BRONZE BUSHED	"E" FACTORS ROLLER BEARING
1	0.96	0.98
2	1.85	1.9
3	2.8	2.9
4	3.6	3.8
5	4.4	4.7
6	5.2	5.6
7	5.9	6.5
8	6.6	7.3
9	7.3	8.2
10	7.9	9.0
11	8.5	9.8
12	9.1	10.6

METHOD OF FIGURING "PARTS OF LINE"

$$\frac{L}{P} = E$$

L = Load Lifted in Lbs.
P = Line Pull in Lbs.
E = Efficiency Factor

For Example: To figure "Parts of Line" required when Load Lifted "L," and Line Pull "P" are known.

$$\frac{32,000 \text{ lbs (Load Lifted "L")}}{6,000 \text{ lbs (Line Pull "P")}} = 5.3 \text{ ("E")}$$

"E" factor 5.3 in table indicated 6 "Parts of Line" required.

REGULAR WOOD SINGLE SHEAVE BLOCK



NO FITTING (NF)

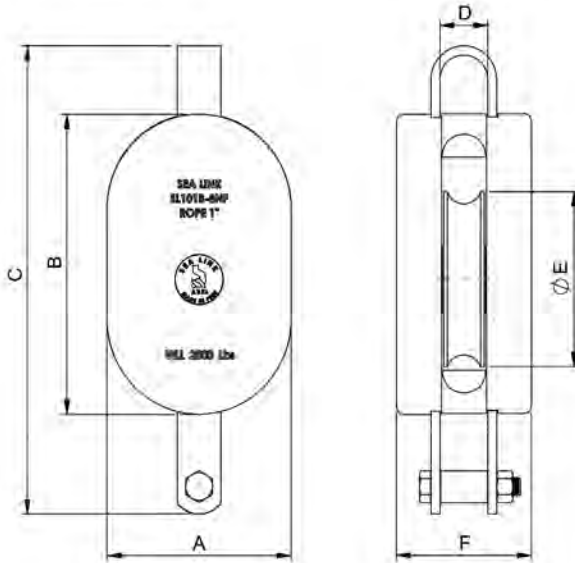

SHACKLE (S)



SWIVEL HOOK (SH)



FIXED HOOK (H)

MODEL NO.	WLL LBS	ROPE ØR	DIMENSIONS (MM)						WEIGHT (LBS)			
									S	SH	H	NF
			A	B	C	D	ØE	F	SHACKLE	SWIVEL HOOK	FIXED HOOK	NO FITTING
SL101B-3	500	3/8	2.3	3.7	6.1	0.6	1.75	1.9	1.2	1.2	1.2	1
SL101B-4	1000	1/2	2.8	4.6	7.5	0.7	2.25	2.2	2.3	2.3	2.3	1.5
SL101B-5	1200	5/8	3.5	5.7	9.2	1.0	3.0	3.1	4	4	4	3
SL101B-6	1800	3/4	4.1	6.9	10.5	1.1	3.5	3.1	5	5	5	4
SL101B-8	2800	7/8 - 1	5.2	8.1	12.7	1.3	4.75	3.8	13	13	13	11
SL101B-10	4000	1 1/8	6.6	10.8	16.0	1.5	6.0	4.0	18	18	18	12
SL101B-12	5000	1 1/4	8.5	12.8	19.3	1.7	8.0	4.7	30	30	30	23

- Blocks built to 4:1 Design Factor
 - Blocks made with Sheave Bronze bushings to SAE40 specifications
 - All accessories are forged
 - Blocks made with Santa Maria Hardwood, which has properties that are favorable for use in wood shell blocks
 - Dimensions shown represent current models and are subject to change
 - Blocks shown are standard models
 - Custom models available upon request
- See our warnings & application instructions

REGULAR WOOD DOUBLE SHEAVE BLOCK



NO FITTING (NF)

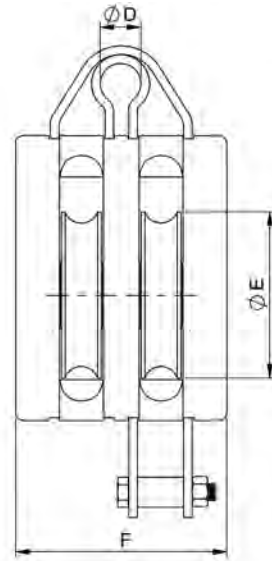

SHACKLE (S)



SWIVEL HOOK (SH)



FIXED HOOK (H)

MODEL NO.	WLL LBS	ROPE	DIMENSIONS (MM)						WEIGHT (LBS)			
									S	SH	H	NF
			ØR	A	B	C	ØD	ØE	F	SHACKLE	SWIVEL HOOK	FIXED HOOK
SL102B-3	800	3/8	2.3	3.7	6.1	0.7	1.75	3.0	1.9	1.9	1.9	1.6
SL102B-4	1400	1/2	2.8	4.6	7.4	0.8	2.25	3.6	3.5	3.5	3.5	2.8
SL102B-5	1800	5/8	3.5	5.7	9.4	1.0	3.0	4.8	6.5	6.5	6.5	5
SL102B-6	2500	3/4	4.1	6.9	10.6	1.0	3.5	5.0	8	8	8	7
SL102B-8	3800	7/8 - 1	5.2	8.1	13.5	1.2	4.75	6.1	16	16	16	14
SL102B-10	6000	1 1/8	6.6	10.8	16.4	1.7	6.0	6.6	27	27	27	22
SL102B-12	8000	1 1/4	8.5	12.8	20.4	2.0	8.0	7.9	49	49	49	42

- Blocks built to 4:1 Design Factor
 - Blocks made with Sheave bronze bushings to SAE40 specifications
 - All accessories are forged
 - Blocks made with Santa Maria Hardwood, which has properties that are favorable for use in wood shell blocks
 - Dimensions shown represent current models and are subject to change
 - Blocks shown are standard models
 - Custom models available upon request
- See our warnings & application instructions

REGULAR WOOD TRIPLE SHEAVE BLOCK



NO FITTING (NF)

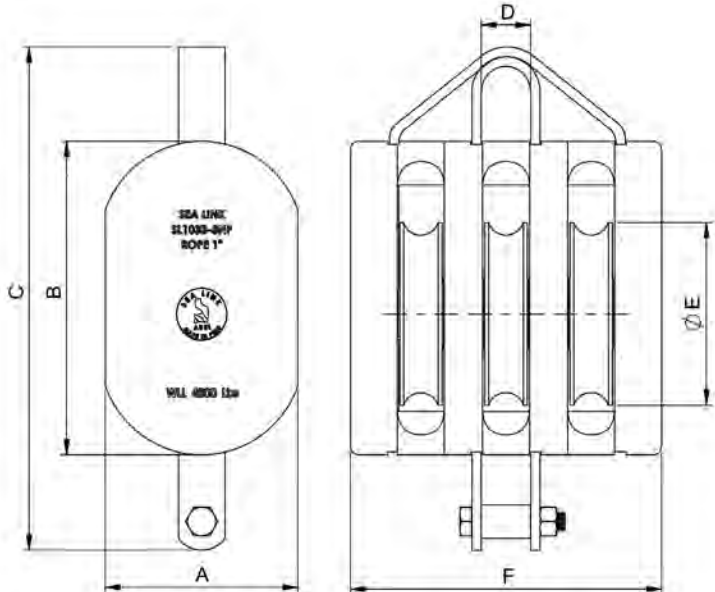

SHACKLE (S)



SWIVEL HOOK (SH)



FIXED HOOK (H)

MODEL NO.	WLL LBS	ROPE ØR	DIMENSIONS (MM)						WEIGHT (LBS)			
									S	SH	H	NF
			SHACKLE	SWIVEL HOOK	FIXED HOOK	NO FITTING						
SL103B-3	1200	3/8	2.3	3.7	6.1	0.7	1.75	4.2	2.3	2.3	2.3	2.0
SL103B-4	1800	1/2	2.8	4.6	7.6	0.8	2.25	5.0	4	4	4	3.4
SL103B-5	2400	5/8	3.5	5.7	9.4	1.0	3.0	6.6	8	8	8	6.6
SL103B-6	3200	3/4	4.1	6.9	11.0	1.3	3.5	7.0	10	10	10	9
SL103B-8	4800	7/8 - 1	5.2	8.1	13.0	1.4	4.75	8.3	20	20	20	18
SL103B-10	8000	1 1/8	6.6	10.8	16.3	1.6	6.0	9.1	34	34	34	29
SL103B-12	10000	1 1/4	8.5	12.8	20.2	1.9	8.0	11.7	63	63	63	56

- Blocks built to 4:1 Design Factor
 - Blocks made with Sheave bronze bushings to SAE40 specifications
 - All accessories are forged
 - Blocks made with Santa Maria Hardwood, which has properties that are favorable for use in wood shell blocks
 - Dimensions shown represent current models and are subject to change
 - Blocks shown are standard models
 - Custom models available upon request
- See our warnings & application instructions

EXTRA HEAVY WOOD SHELL SINGLE BLOCK



NO FITTING (NF)

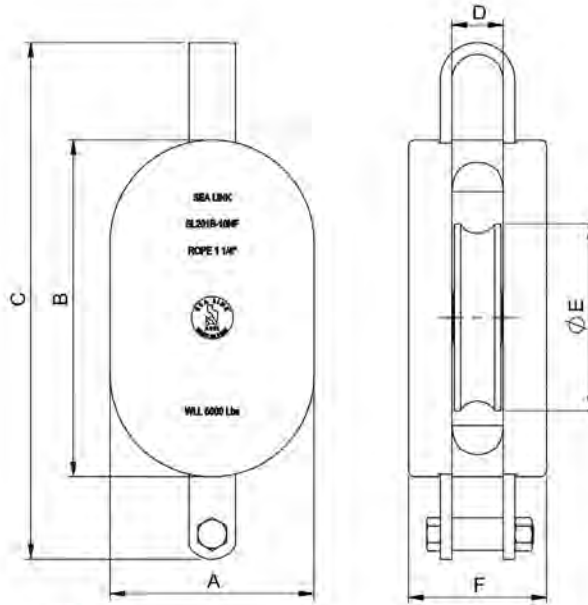

SHACKLE (S)



SWIVEL HOOK (SH)



FIXED HOOK (H)

MODEL NO.	WLL LBS	ROPE	DIMENSIONS (MM)						WEIGHT (LBS)			
									S	SH	H	NF
			ØR	A	B	C	D	ØE	F	SHACKLE	SWIVEL HOOK	FIXED HOOK
SL201B-6	2000	3/4	4.1	6.9	10.4	1.3	3.5	3.7	5.5	5.5	5.5	4
SL201B-8	3300	1 1/8	5.3	8.7	13.8	1.5	4.75	4.2	13	13	13	10
SL201B-10	5000	1 1/4	6.6	10.8	16.6	1.7	6.0	4.4	22	22	22	17
SL201B-12	6800	1 1/2	8.5	12.8	21.0	1.9	8.0	5.2	37	37	37	28
SL201B-14	9600	1 3/4	10.2	16.3	25.6	2.2	9.5	5.8	59	59	59	46
SL201B-16	12000	2	11.7	18.7	29.6	2.7	11.0	6.7	82	82	82	65

- Blocks built to 4:1 Design Factor.
 - Blocks made with Bronze Bushed sheaves to SAE40 specifications.
 - Available with self-lubricating graphite bronze sheave bushing per ASTM B438.
 - All accessories are forged.
 - Blocks made with Santa Maria Hardwood, which has properties that are favorable for use in wood shell blocks.
 - Dimensions shown represent current models and are subject to change.
 - Blocks shown here are standard models.
 - Custom models available upon request.
- See our warnings & application instructions

EXTRA HEAVY WOOD SHELL DOUBLE BLOCK



NO FITTING (NF)

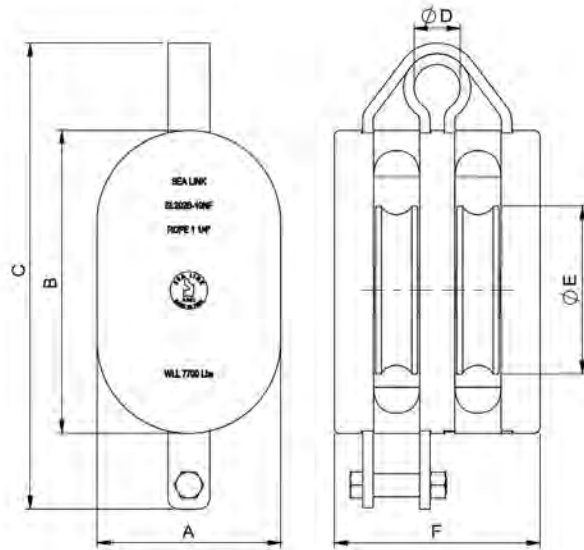

SHACKLE (S)



SWIVEL HOOK (SH)



FIXED HOOK (H)

MODEL NO.	WLL LBS	ROPE ØR	DIMENSIONS (MM)						WEIGHT (LBS)			
									S	SH	H	NF
			A	B	C	ØD	ØE	F	SHACKLE	SWIVEL HOOK	FIXED HOOK	NO FITTING
SL202B-6	3300	3/4	4.1	6.9	10.7	1.0	3.5	5.8	8	8	8	7
SL202B-8	5100	1 1/8	5.3	8.7	14.8	1.5	4.75	6.8	20	20	20	17
SL202B-10	7700	1 1/4	6.6	10.8	16.6	1.7	6.0	7.4	34	34	34	29
SL202B-12	10600	1 1/2	8.5	12.8	21.0	2.0	8.0	8.4	59	59	59	49
SL202B-14	15000	1 3/4	10.2	16.3	25.6	2.2	9.5	9.4	96	96	96	84
SL202B-16	19000	2	11.7	18.7	30.1	2.2	11.0	11.2	132	132	132	114

- Blocks built to 4:1 Design Factor.
 - Blocks made with Bronze Bushed sheaves to SAE40 specifications.
 - Available with self-lubricating graphite bronze sheave bushing per ASTM B438.
 - All accessories are forged.
 - Blocks made with Santa Maria Hardwood, which has properties that are favorable for use in wood shell blocks.
 - Dimensions shown represent current models and are subject to change.
 - Blocks shown here are standard models.
 - Custom models available upon request.
- See our warnings & application instructions

EXTRA HEAVY WOOD SHELL TRIPLE BLOCK



NO FITTING (NF)

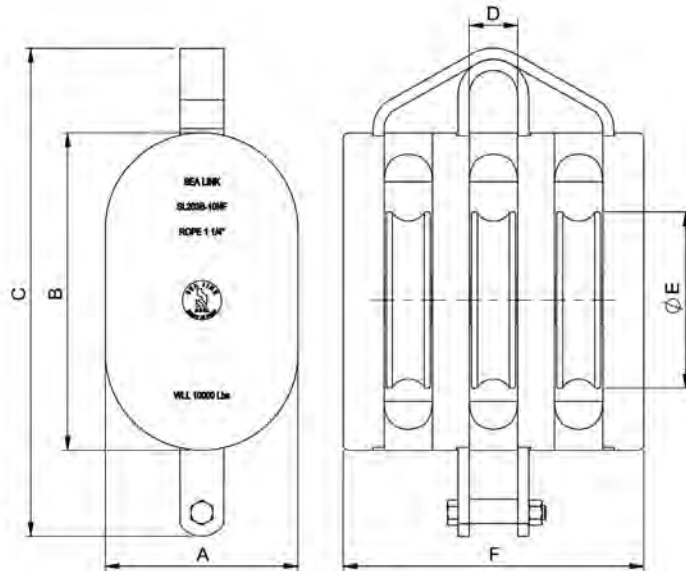

SHACKLE (S)



SWIVEL HOOK (SH)



FIXED HOOK (H)

MODEL NO.	WLL LBS	ROPE ØR	DIMENSIONS (MM)						WEIGHT (LBS)			
			A	B	C	D	ØE	F	S SHACKLE	SH SWIVEL HOOK	H FIXED HOOK	NF NO FITTING
SL203B-6	4000	3/4	4.1	6.9	10.7	1.3	3.5	8.0	11	11	11	9
SL203B-8	7000	1 1/8	5.3	8.7	14.8	1.3	4.75	9.3	25	25	25	22
SL203B-10	10000	1 1/4	6.6	10.8	16.6	1.7	6.0	10.3	43	43	43	37
SL203B-12	14000	1 1/2	8.5	12.8	20.7	2.0	8.0	11.7	73	73	73	63
SL203B-14	20000	1 3/4	10.2	16.3	25.6	2.2	9.5	13.1	114	114	114	102
SL203B-16	24000	2	11.7	18.7	30.1	2.7	11.0	15.7	166	166	166	149

- Blocks built to 4:1 Design Factor.
 - Blocks made with Bronze Bushed sheaves to SAE40 specifications.
 - Available with self-lubricating graphite bronze sheave bushing per ASTM B438.
 - All accessories are forged.
 - Blocks made with Santa Maria Hardwood, which has properties that are favorable for use in wood shell blocks.
 - Dimensions shown represent current models and are subject to change.
 - Blocks shown here are standard models.
 - Custom models available upon request.
- See our warnings & application instructions

EXTRA HEAVY NON-TOPPLING WOOD SHELL BLOCK SINGLE



NO FITTING (NF)
NO BECKET (NB)

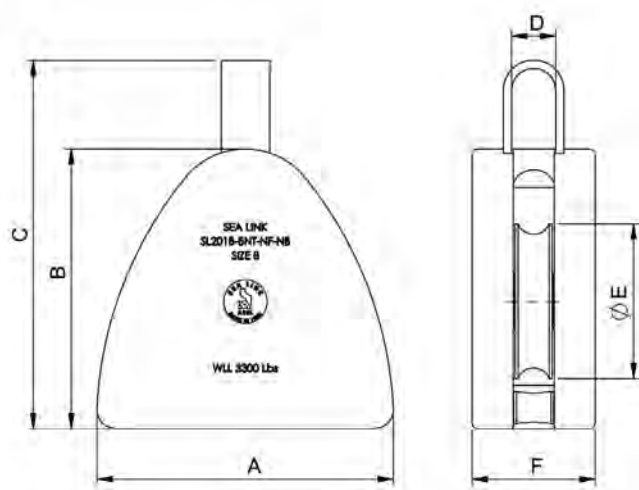

SHACKLE (S)
NO BECKET (NB)



SHACKLE (S)

MODEL NO.	WLL LBS	ROPE ØR	DIMENSIONS (MM)							WEIGHT (LBS)	
			A	B	C	D	ØE	F	SHACKLE	NF	S
										NO FITTING	SHACKLE
SL201B-8 NT	3300	1 1/8	9.1	8.6	11.3	1.3	4.8	3.8	7/8	10	13
SL201B-10 NT	5000	1 1/4	11.8	8.7	14.8	1.3	4.75	9.3	1	18	23
SL201B-12 NT	6800	1 1/2	6.6	10.8	16.6	1.7	6.0	10.3	1 1/8	36	44

- Blocks built to 4:1 Design Factor.
 - Blocks made with Bronze Bushed sheaves to SAE40 specifications.
 - Available with self-lubricating graphite bronze sheave bushing per ASTM B438.
 - All accessories are forged.
 - Blocks made with Santa Maria Hardwood, which has properties that are favorable for use in wood shell blocks.
 - Dimensions shown represent current models and are subject to change.
 - Blocks shown here are standard models.
 - Custom models available upon request.
- See our warnings & application instructions

EXTRA HEAVY NON-TOPPLING WOOD SHELL BLOCK DOUBLE



NO FITTING (NF)
NO BECKET (NB)

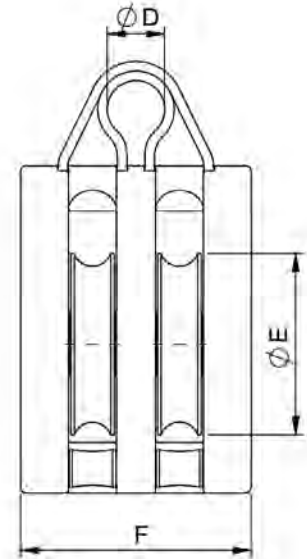
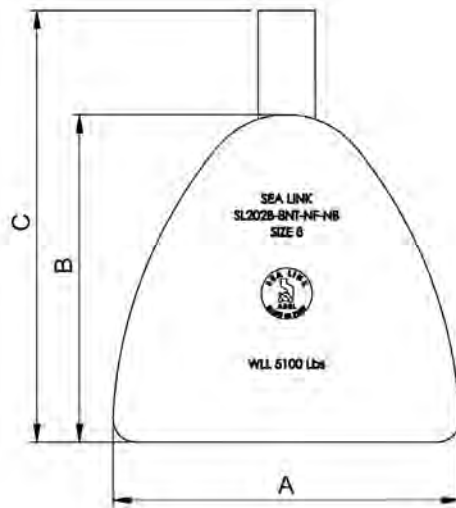

SHACKLE (S)
NO BECKET (NB)

SHACKLE (S)

MODEL NO.	WLL LBS	ROPE ØR	DIMENSIONS (MM)							WEIGHT (LBS)	
			A	B	C	ØD	ØE	F	SHACKLE	NF	S
										NO FITTING	SHACKLE
SL202B-8 NT	5100	1 1/8	9.1	8.6	11.6	1.5	4.8	6.1	7/8	17	21
SL202B-10 NT	7700	1 1/4	11.8	11.2	15.2	1.6	6.3	7.2	1	33	39
SL202B-12 NT	10600	1 1/2	15.4	14.4	19.5	1.7	8.0	8.4	1 1/8	64	70

- Blocks built to 4:1 Design Factor.
- Blocks made with Bronze Bushed sheaves to SAE40 specifications.
- Available with self-lubricating graphite bronze sheave bushing per ASTM B438.
- All accessories are forged.
- Blocks made with Santa Maria Hardwood, which has properties that are favorable for use in wood shell blocks.
- Dimensions shown represent current models and are subject to change.
- Blocks shown here are standard models.
- Custom models available upon request.

See our warnings & application instructions

SEA-LINK
Quality Rigging Products

EXTRA HEAVY NON-TOPPLING WOOD SHELL BLOCK TRIPLE



NO FITTING (NF)
NO BECKET (NB)

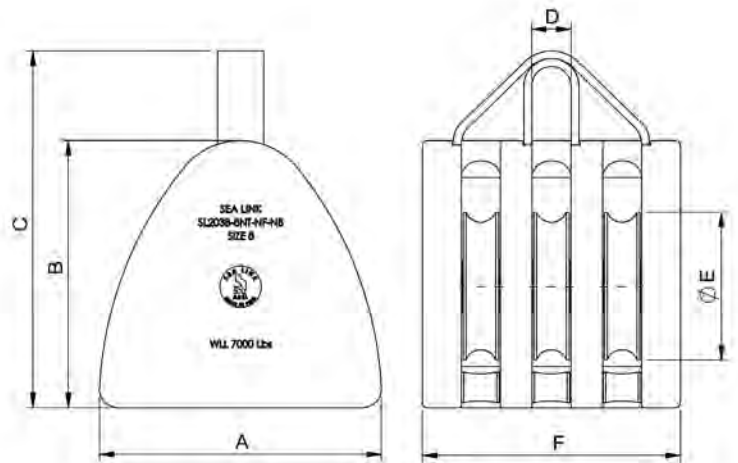

SHACKLE (S)
NO BECKET (NB)



SHACKLE (S)

MODEL NO.	WLL LBS	ROPE ØR	DIMENSIONS (MM)							WEIGHT (LBS)	
			A	B	C	D	ØE	F	SHACKLE	NF	S
										NO FITTING	SHACKLE
SL203B-8 NT	7000	1 1/8	9.1	8.6	11.6	1.5	4.8	8.3	7/8	22	26
SL203B-10 NT	10000	1 1/4	11.8	11.2	15.2	1.7	6.3	10.0	1	44	48
SL203B-12 NT	14000	1 1/2	15.4	14.4	19.5	1.9	8.0	11.7	1 1/8	80	88

- Blocks built to 4:1 Design Factor.
- Blocks made with Bronze Bushed sheaves to SAE40 specifications.
- Available with self-lubricating graphite bronze sheave bushing per ASTM B438.
- All accessories are forged.
- Blocks made with Santa Maria Hardwood, which has properties that are favorable for use in wood shell blocks.
- Dimensions shown represent current models and are subject to change.
- Blocks shown here are standard models.
- Custom models available upon request.

See our warnings & application instructions

STANDARD STEEL SHELL MANILA ROPE SINGLE BLOCK



NO FITTING (NF)

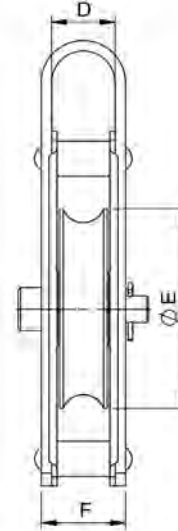
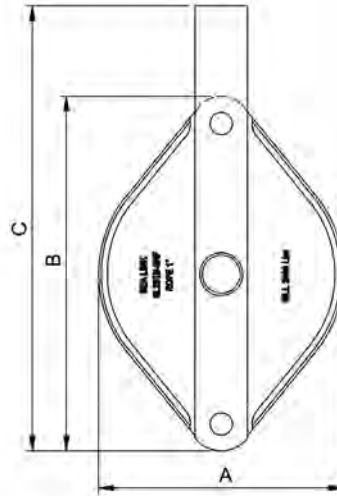

SHACKLE (S)



SWIVEL HOOK (SH)



FIXED HOOK (H)

MODEL NO.	WLL LBS	ROPE ØR	DIMENSIONS (MM)						WEIGHT (LBS)			
									S	SH	H	NF
			A	B	C	D	ØE	F	SHACKLE	SWIVEL HOOK	FIXED HOOK	NO FITTING
SL251B-3	500	3/8	2.2	3.7	4.8	0.9	1.75	1.1	1.5	1.5	1.5	1.2
SL251B-4	1000	3/8 - 1/2	2.9	4.8	5.9	1.0	2.25	1.3	2.4	2.4	2.4	1.7
SL251B-6	1800	5/8 - 3/4	4.3	7.0	8.7	1.4	3.5	1.8	5.3	5.3	5.3	3.8
SL251B-8	2800	7/8 - 1	5.8	8.5	10.6	1.5	4.75	2.	10	10	10	8
SL251B-10	4000	1 - 1 1/4	6.8	11.0	13.7	1.7	6.0	2.2	17	17	17	11
SL251B-12	5000	1 1/4 - 1 1/2	8.6	13.0	16.1	2.0	8.0	2.8	31	31	31	21

- Blocks built to 4:1 Design Factor.
- Blocks made with Bronze Bushed sheaves to SAE40 specifications.
- All accessories are forged.
- Dimensions shown represent current models and are subject to change.
- Blocks shown here are standard models.
- Custom models available upon request.

See our warnings & application instructions

STANDARD STEEL SHELL MANILA ROPE DOUBLE BLOCK



NO FITTING (NF)

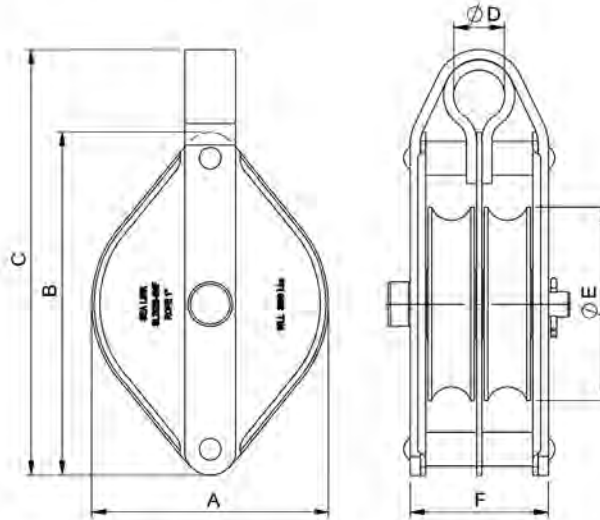

SHACKLE (S)



SWIVEL HOOK (SH)



FIXED HOOK (H)

MODEL NO.	WLL LBS	ROPE ØR	DIMENSIONS (MM)						WEIGHT (LBS)			
									S	SH	H	NF
			A	B	C	ØD	ØE	F	SHACKLE	SWIVEL HOOK	FIXED HOOK	NO FITTING
SL252B-3	800	3/8	2.2	3.7	4.9	0.7	1.75	1.9	2.2	2.2	2.2	1.8
SL252B-4	1400	3/8 - 1/2	2.9	4.8	6.1	1.1	2.25	2.1	3.5	3.5	3.5	2.8
SL252B-6	2500	5/8 - 3/4	4.3	7.0	9.1	1.2	3.5	3.0	7.5	7.5	7.5	6
SL252B-8	3800	7/8 - 1	5.8	8.5	10.5	1.2	4.75	3.4	14	14	14	12
SL252B-10	6000	1 - 1 1/4	6.8	11.0	13.3	1.4	6.0	3.9	24	24	24	19
SL252B-12	8000	1 1/4 - 1 1/2	8.6	13.0	16.2	1.5	8.0	4.8	48	48	48	39

- Blocks built to 4:1 Design Factor.
 - Blocks made with Bronze Bushed sheaves to SAE40 specifications.
 - All accessories are forged.
 - Dimensions shown represent current models and are subject to change.
 - Blocks shown here are standard models.
 - Custom models available upon request.
- See our warnings & application instructions

STEEL SHELL MALLEABLE STYLE MANILA ROPE SINGLE BLOCK



NO FITTING (NF)

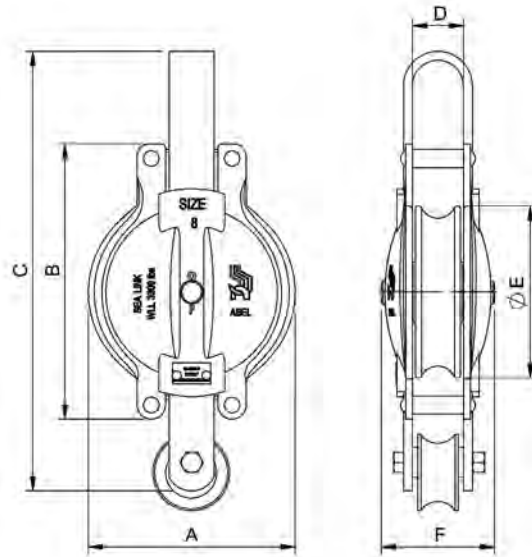

SHACKLE (S)



SWIVEL HOOK (SH)



FIXED HOOK (H)



SPECIAL

MODEL NO.	WLL LBS	ROPE ØR	DIMENSIONS (MM)						WEIGHT (LBS)			
									S	SH	H	NF
			SHACKLE	SWIVEL HOOK	FIXED HOOK	NO FITTING						
SL321B-3	700	3/8	2.4	3.3	5.7	0.7	1.75	1.7	1.7	1.7	1.3	
SL321B-4	1100	3/8 - 1/2	2.9	4.3	7.0	0.75	2.25	1.8	3	3	3	2.2
SL321B-6	2000	5/8 - 3/4	4.3	6.0	9.8	1.3	3.5	2.8	6	6	6	4.4
SL321B-8	3300	7/8 - 1	5.7	7.6	12.2	1.4	4.75	3.3	12	12	12	10
SL321B-10	5000	1 - 1 1/4	6.8	9.0	14.5	1.7	6.0	3.7	20	20	20	17
SL321B-12	8900	1 1/4 - 1 1/2	9.3	12.0	18.6	1.9	8.0	4.1	42	42	42	32

- Blocks built to 4:1 Design Factor.
- Blocks made with Bronze Bushed sheaves to SAE40 specifications.
- Available with self-lubricating graphite bronze sheave bushing per ASTM B438.
- All accessories are forged.
- Dimensions shown represent current models and are subject to change.
- Blocks shown are standard models.
- Custom models available upon request.

See our warnings & application instructions

STEEL SHELL MALLEABLE STYLE MANILA ROPE DOUBLE BLOCK



NO FITTING (NF)

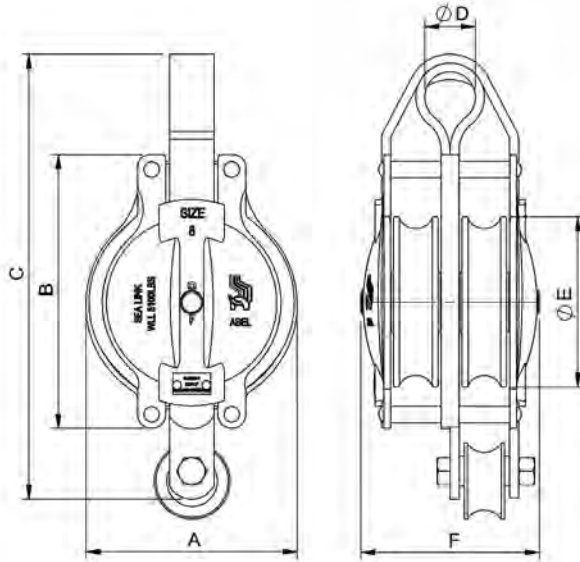

SHACKLE (S)



SWIVEL HOOK (SH)



FIXED HOOK (H)



SPECIAL

MODEL NO.	WLL LBS	ROPE ØR	DIMENSIONS (MM)						WEIGHT (LBS)			
			A	B	C	ØD	ØE	F	S	SH	H	NF
									SHACKLE	SWIVEL HOOK	FIXED HOOK	NO FITTING
SL322B-3	1000	3/8	2.4	3.3	5.9	0.6	1.75	2.6	2.8	2.8	2.8	2.5
SL322B-4	1600	3/8 - 1/2	2.9	4.3	7.2	0.6	2.25	2.8	4.6	4.6	4.6	3.8
SL322B-6	3300	5/8 - 3/4	4.3	6.0	10.0	1.1	3.5	4.3	10	10	10	8
SL322B-8	5100	7/8 - 1	5.7	7.6	12.4	1.4	4.75	4.9	18	18	18	16
SL322B-10	7700	1 - 1 1/4	6.8	9.0	14.8	1.5	6.0	6.0	32	32	32	29
SL322B-12	15600	1 1/4 - 1 1/2	9.3	12.0	18.9	1.9	8.0	7.2	56	56	56	46

- Blocks built to 4:1 Design Factor.
 - Blocks made with Bronze Bushed sheaves to SAE40 specifications.
 - Available with self-lubricating graphite bronze sheave bushing per ASTM B438.
 - All accessories are forged.
 - Dimensions shown represent current models and are subject to change.
 - Blocks shown are standard models.
 - Custom models available upon request.
- See our warnings & application instructions

STEEL SHELL MALLEABLE STYLE MANILA ROPE TRIPLE BLOCK



NO FITTING (NF)

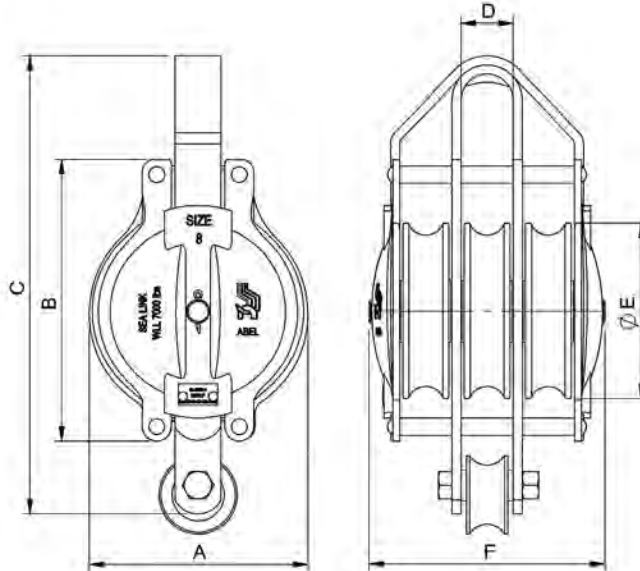

SHACKLE (S)



SWIVEL HOOK (SH)



FIXED HOOK (H)



SPECIAL

MODEL NO.	WLL LBS	ROPE ØR	DIMENSIONS (MM)						WEIGHT (LBS)			
									S	SH	H	NF
			A	B	C	D	ØE	F	SHACKLE	SWIVEL HOOK	FIXED HOOK	NO FITTING
SL323B-3	1400	3/8	2.4	3.3	5.9	0.7	1.75	3.5	4.3	4.3	4.3	4.0
SL323B-4	2200	3/8 - 1/2	2.9	4.3	7.2	0.75	2.25	3.7	5.6	5.6	5.6	4.8
SL323B-6	4000	5/8 - 3/4	4.3	6.0	10.0	1.3	3.5	5.9	13	13	13	12
SL323B-8	7000	7/8 - 1	5.7	7.6	12.4	1.4	4.75	6.3	24	24	24	22
SL323B-10	10000	1 - 1 1/4	6.8	9.0	14.8	1.7	6.0	7.6	39	39	39	35
SL323B-12	17000	1 1/4 - 1 1/2	9.3	12.0	18.9	1.9	8.0	9.3	70	70	70	61

- Blocks built to 4:1 Design Factor.
 - Blocks made with Bronze Bushed sheaves to SAE40 specifications.
 - Available with self-lubricating graphite bronze sheave bushing per ASTM B438.
 - All accessories are forged.
 - Dimensions shown represent current models and are subject to change.
 - Blocks shown are standard models.
 - Custom models available upon request.
- See our warnings & application instructions

WOOD SHELL SNATCH BLOCK FOR MANILA ROPE



DRILLED SWIVEL EYE W/ SHACKLE (DS)

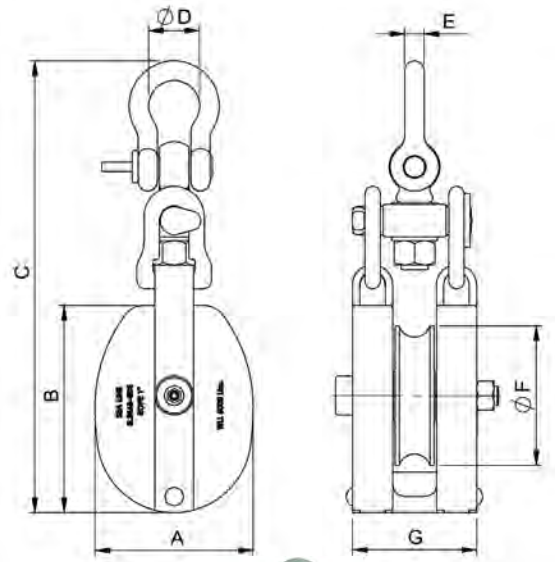

OBLONG SWIVEL EYE (OS)



SWIVEL HOOK (SH)

MODEL NO.	WLL LBS	ROPE ØR	DIMENSIONS (MM)							WEIGHT (LBS)		
			A	B	C	ØD	E	ØF	G	DS	OS	SH
										SWIVEL EYE W/SHACKLE	OBLONG SWIVEL EYE	SWIVEL HOOK
SL386B-4	1200	5/8 - 3/4	3.0	3.9	8.9	1.0	0.37	2.5	2.8	3.4	3.4	3.4
SL386B-6	3000	3/4 - 7/8	3.6	4.6	10.9	1.3	0.5	3.0	3.1	7	7	7
SL386B-8	5000	7/8 - 1	5.1	6.7	14.6	1.7	0.62	4.5	4.0	12	12	12
SL386B-10	8000	1 - 1 1/4	6.6	8.4	17.7	2.0	0.74	5.8	4.9	22	22	22
SL386B-12	10000	1 1/4 - 1 1/2	8.0	9.9	20.7	2.3	0.87	6.8	5.6	35	35	35
SL386B-14	12000	1 1/2 - 1 3/4	8.9	11.3	23.1	2.7	1	8.0	6.5	50	50	50
SL386B-16	16000	1 3/4 - 2	9.9	12.6	26.3	2.9	1.12	9.0	6.7	73	73	73
SL386B-22	22000	3	13.0	17.4	32.1	3.2	1.25	11.8	9.3	139	139	139

- Blocks built to 4:1 Design Factor.
 - Blocks made with Bronze Bushed sheaves to SAE40 specifications.
 - Available with self-lubricating graphite bronze sheave bushing per ASTM B438.
 - All accessories are forged.
 - Blocks made with Santa Maria Hardwood, which has properties that are favorable for use in wood shell blocks.
 - Dimensions shown represent current models and are subject to change.
 - Blocks shown are standard models.
 - Custom models available upon request.
- See our warnings & application instructions

STEEL SHELL SNATCH BLOCK FOR MANILA ROPE



DRILLED SWIVEL EYE W/
SHACKLE (DS)

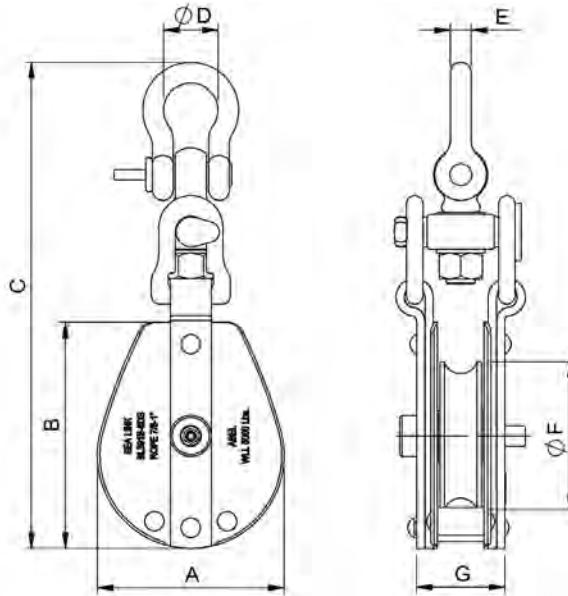

OBLONG SWIVEL EYE (OS)



SWIVEL HOOK (SH)

MODEL NO.	WLL LBS	ROPE ØR	DIMENSIONS (MM)							WEIGHT (LBS)		
			A	B	C	ØD	E	ØF	G	DS	OS	SH
										SWIVEL EYE W/SHACKLE	OBLONG SWIVEL EYE	SWIVEL HOOK
SL391B-4	1200	5/8 - 3/4	3.0	4.0	8.9	1.0	0.37	2.5	1.9	3.8	3.8	3.8
SL391B-6	3000	3/4 - 7/8	4.0	4.9	11.8	1.3	0.5	3.0	2.2	8	8	8
SL391B-8	5000	7/8 - 1	5.6	6.9	15.0	1.7	0.62	4.5	2.7	14	14	14
SL391B-10	8000	1 - 1 1/4	6.8	6.8	18.1	2.0	0.75	5.8	3.1	28	28	28
SL391B-12	10000	1 1/4 - 1 1/2	8.8	10.3	20.9	2.3	0.87	6.8	3.9	35	35	35
SL391B-14	12000	1 1/2 - 1 3/4	9.0	11.9	23.8	2.7	1	8.0	4.3	46	46	46
SL391B-16	16000	1 3/4 - 2	10.2	13.4	26.4	2.9	1.12	9.0	4.6	62	62	62

- Blocks built to 4:1 Design Factor.
 - Blocks made with Bronze Bushed sheaves to SAE40 specifications.
 - Available with self-lubricating graphite bronze sheave bushing per ASTM B438.
 - All accessories are forged.
 - Dimensions shown represent current models and are subject to change.
 - Blocks shown are standard models.
 - Custom models available upon request.
- See our warnings & application instructions

STEEL SHELL SNATCH BLOCK - 2, 4 & 8 TON



SWIVEL SHACKLE (SS)

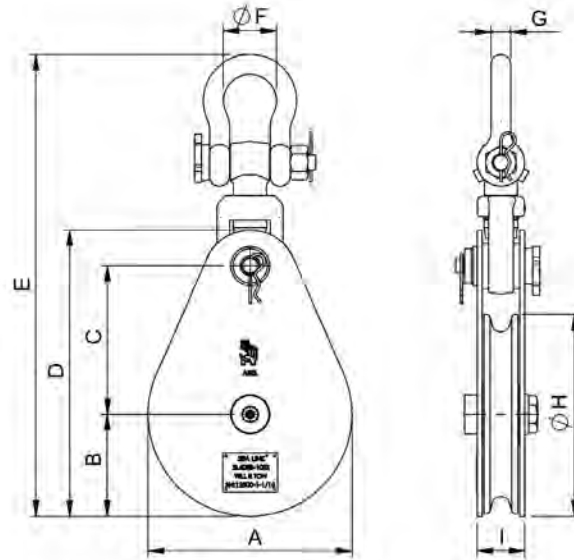

TAILBOARD (TB)



SWIVEL HOOK (SH)



TOP DEAD END (TDE)

MODEL NO.	WLL TN	WIRE ROPE ØR	DIMENSIONS (MM)									WEIGHT (LBS)		
			A	B	C	D	E	ØF	G	ØH	I	SS	SH	TB
												SWIVEL SHACKLE	SWIVEL HOOK	TAILBOARD
SL402B-3	2	5/16 - 3/8	3.0	1.5	2.7	5	9.5	1.3	0.5	3	1.4	5	5	
SL404B-4.5	4	3/8 - 1/2	4.6	2.3	4.2	7.6	13.5	1.9	0.7	4.5	1.9	13	13	
SL408B-6	8	5/8 - 3/4	6	3	5.1	9.9	18.8	2.7	1	6	2.3	30	33	18
SL408B-8	8	5/8 - 3/4	8	4	6.3	12	20.9	2.7	1	8	2.4	39	42	28
SL408B-10	8	5/8 - 3/4	10.2	5.1	7.4	14.4	23.3	2.7	1	10	2.4	46	49	34
SL408B-12	8	5/8 - 3/4	12.0	6	9.2	17	25.9	2.7	1	12	2.4	58	61	47

- Blocks built to 4:1 Design Factor.
 - Available with these top fittings - Swivel Hook (SH), Swivel Shackle (SS), Tailboard (TB).
 - Can be ordered with Top Dead End (TDE).
 - Sheaves have bronze bushings.
 - All accessories are forged.
 - Products are manufactured under the Standard ASME B30.26
 - Dimensions shown represent current models and are subject to change.
 - Blocks shown are standard models.
 - Custom models available upon request.
- See our warnings & application instructions

STEEL SHELL SNATCH BLOCK - 12 TON



SWIVEL SHACKLE (SS)

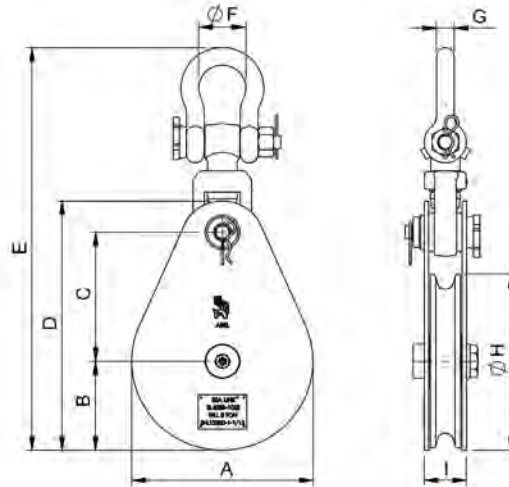

TAILBOARD (TB)



SWIVEL HOOK (SH)



TOP DEAD END (TDE)

MODEL NO.	WLL TN	WIRE ROPE ØR	DIMENSIONS (MM)									WEIGHT (LBS)		
			A	B	C	D	E	ØF	G	ØH	I	SS	SH	TB
												SWIVEL SHACKLE	SWIVEL HOOK	TAILBOARD
SL412B-6	12	3/4 - 7/8	6	3	5.1	9.9	18.8	2.7	1	6	2.3	30	33	19
SL412B-8	12	3/4 - 7/8	8	4	6.3	12	20.9	2.7	1	8	2.4	39	42	28
SL412B-10	12	3/4 - 7/8	10.2	5.1	7.4	14.4	23.3	2.7	1	10	2.4	46	49	34
SL412B-12	12	3/4 - 7/8	12	6	9.2	17	25.9	2.7	1	12	2.4	58	61	47

MODEL NO.	WLL TN	WIRE ROPE ØR	DIMENSIONS (MM)									WEIGHT (LBS)		
			A	B	C	D	E	ØF	G	ØH	I	SS	SH	TB
												SWIVEL SHACKLE	SWIVEL HOOK	TAILBOARD
SL412R-8	12	3/4 - 7/8	8	4	6.3	12	20.9	2.7	1	8	2.4	39	42	28
SL412R-10	12	3/4 - 7/8	10.2	5.1	7.4	14.4	23.3	2.7	1	10	2.4	46	49	34
SL412R-12	12	3/4 - 7/8	12	6	9.2	17	25.9	2.7	1	12	2.4	58	61	47

- Blocks built to 4:1 Design Factor.
 - Available with these top fittings - Swivel Hook (SH), Swivel Shackle (SS), Tailboard (TB).
 - Can be ordered with Top Dead End (TDE).
 - Available with Bronze Bushing (B) or Roller Bearing (R).
 - All accessories are forged.
 - Products are manufactured under the Standard ASME B30.26
 - Dimensions shown represent current models and are subject to change.
 - Blocks shown are standard models.
 - Custom models available upon request.
- See our warnings & application instructions

STEEL SHELL SNATCH BLOCK - 15 TON



SWIVEL SHACKLE (SS)

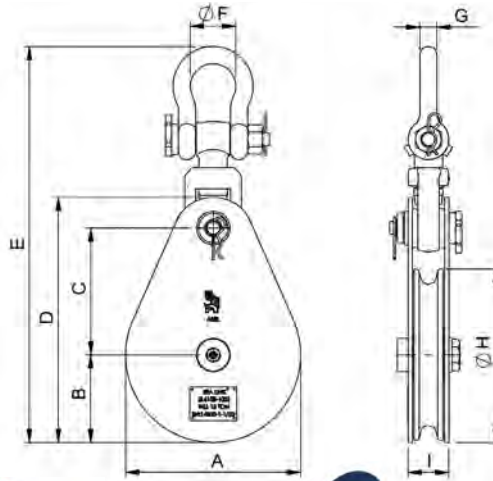

TAILBOARD (TB)



TOP DEAD END (TDE)

MODEL NO.	WLL TN	WIRE ROPE ØR	DIMENSIONS (MM)									WEIGHT (LBS)	
			A	B	C	D	E	ØF	G	ØH	I	SS	TB
			SWIVEL SHACKLE	TAILBOARD									
SL415B-8	15	3/4 - 7/8	8	4	7	12.5	23.2	3	1.1	8	3	59	38
SL415B-10	15	3/4 - 7/8	10.2	5.1	7.9	14.9	25.6	3	1.1	10	3	69	47
SL415B-12	15	3/4 - 7/8	12	6	9.2	17.5	28.2	3	1.1	12	3	80	57
SL415B-16	15	3/4 - 7/8	16.4	8.2	11.5	21.6	32.1	3	1.1	16	3	121	99

MODEL NO.	WLL TN	WIRE ROPE ØR	DIMENSIONS (MM)									WEIGHT (LBS)	
			A	B	C	D	E	ØF	G	ØH	I	SS	TB
			SWIVEL SHACKLE	TAILBOARD									
SL415R-8	15	3/4 - 7/8	8	4	7	12.5	23.2	3	1.1	8	3	59	38
SL415R-10	15	3/4 - 7/8	10.2	5.1	7.9	14.9	25.6	3	1.1	10	3	69	47
SL415R-12	15	3/4 - 7/8	12	6	9.2	17.5	28.2	3	1.1	12	3	80	57
SL415R-16	15	3/4 - 7/8	16.4	8.2	11.5	21.6	32.1	3	1.1	16	3	121	99

- Blocks built to 4:1 Design Factor.
 - Available with these top fittings - Swivel Shackle (SS), Tailboard (TB).
 - Can be ordered with Top Dead End (TDE).
 - Available with Bronze Bushing (B) or Roller Bearing (R).
 - All accessories are forged.
 - Products are manufactured under the Standard ASME B30.26
 - Dimensions shown represent current models and are subject to change.
 - Blocks shown are standard models.
 - Custom models available upon request.
- See our warnings & application instructions

STEEL SHELL SNATCH BLOCK - 20 TON



SWIVEL SHACKLE (SS)

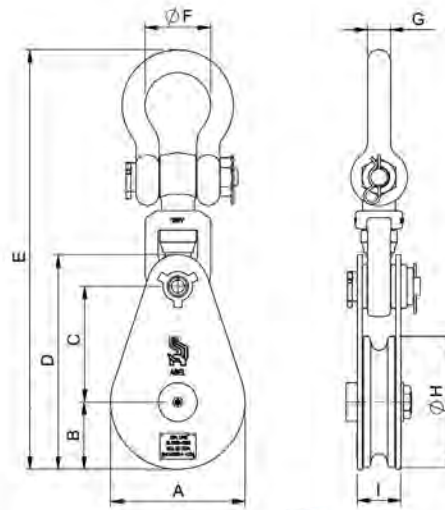

TAILBOARD (TB)



TOP DEAD END (TDE)

MODEL NO.	WLL TN	WIRE ROPE	DIMENSIONS (MM)									WEIGHT (LBS)		
			ØR	A	B	C	D	E	ØF	G	ØH	I	SS	TB
													SWIVEL SHACKLE	TAILBOARD
SL420B-8	20	1 - 1/8	8	4	8	14.4	28.1	3.6	1.4	8	3.3	90	51	
SL420B-10	20	1 - 1/8	10.2	5.1	8.8	16.4	30.1	3.6	1.4	10	3.3	103	64	
SL420B-12	20	1 - 1/8	12	6	10.0	18.4	32.2	3.6	1.4	12	3.3	118	79	

MODEL NO.	WLL TN	WIRE ROPE	DIMENSIONS (MM)									WEIGHT (LBS)		
			ØR	A	B	C	D	E	ØF	G	ØH	I	SS	TB
													SWIVEL SHACKLE	TAILBOARD
SL420R-8	20	1 - 1/8	8	4	8	14.4	28.1	3.6	1.4	8	3.3	90	51	
SL420R-10	20	1 - 1/8	10.2	5.1	8.8	16.4	30.1	3.6	1.4	10	3.3	103	64	
SL420R-12	20	1 - 1/8	12	6	10.0	18.4	32.2	3.6	1.4	12	3.3	118	79	

- Blocks built to 4:1 Design Factor.
 - Available with these top fittings - Swivel Shackle (SS), Tailboard (TB).
 - Can be ordered with Top Dead End (TDE).
 - Available with Bronze Bushing (B) or Roller Bearing (R).
 - All accessories are forged.
 - Products are manufactured under the Standard ASME B30.26
 - Dimensions shown represent current models and are subject to change.
 - Blocks shown are standard models.
 - Custom models available upon request.
- See our warnings & application instructions

CARGO HOISTING BLOCKS



DRILLED SWIVEL EYE (DS)

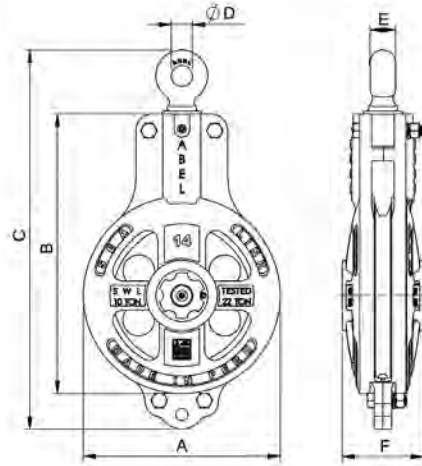

DSS-SWIVEL EYE WITH ANCHOR SHACKLE

MODEL NO.	WLL LBS	WIRE ROPE	SHEAVE	DIMENSIONS (MM)							WEIGHT (LBS)
		ØR	ØS	A	B	C	ØD	E	F	G	
SL561R-12DS	11000	5/8 - 3/4	12	13.1	17.6	26.4	3.2	1.5	1.1	5.5	100
SL561R-14DS	22000	3/4 - 7/8	14	15.2	21.6	30.8	3.2	1.5	1.3	6.3	136
SL561R-16DS	22000	7/8 - 1	16	17.1	23.4	33.8	3.8	1.8	1.4	6.3	150



OBLONG SWIVEL EYE (OS)

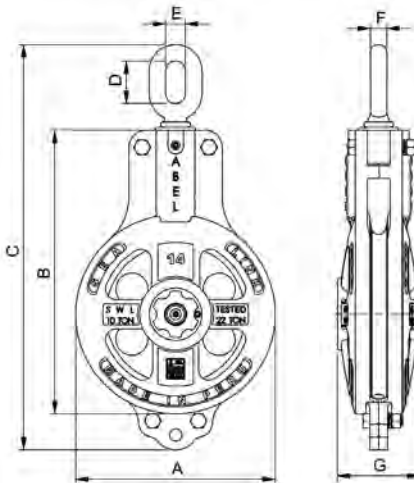

OSS-OBLONG SWIVEL EYE W/UPSET ANCHOR SHACKLE

MODEL NO.	WLL LBS	WIRE ROPE	SHEAVE	DIMENSIONS (MM)						WEIGHT (LBS)
		ØR	ØS	A	B	C	D	E	F	
SL561R-12OS	11000	5/8 - 3/4	12	13.1	17.6	24.8	1.5	1.7	5.5	100
SL561R-14OS	22000	3/4 - 7/8	14	15.2	21.6	29.3	1.6	2.0	6.3	138
SL561R-16OS	22000	7/8 - 1	16	17.1	23.4	31.5	1.7	2.1	6.3	150

- Blocks built to 4:1 Design Factor.
 - Includes Timken Tapered Roller Bearings.
 - Top Fittings Available - Drilled Swivel Eye (SE), Oblong Swivel Eye (OS), plus optional as listed.
 - All accessories are forged.
 - Dimensions shown represent current models and are subject to change.
 - Blocks shown are standard models.
 - Custom models available upon request.
- See our warnings & application instructions

MEDIUM WEIGHT OVAL PATTERN CONSTRUCTION BLOCK-SINGLE SHEAVE

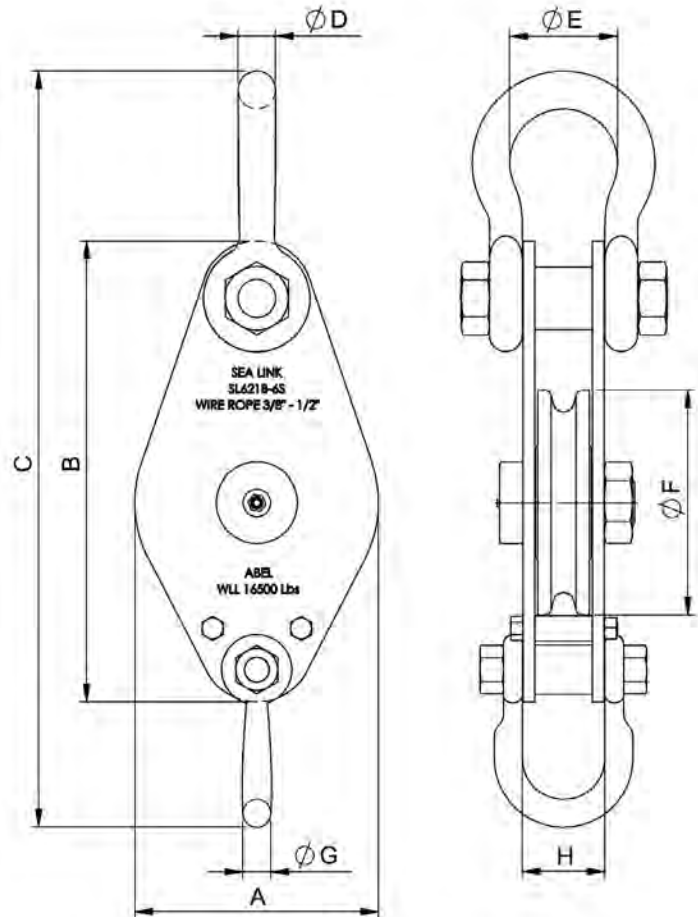

MODEL NO.	WLL LBS	WIRE ROPE ØR	DIMENSIONS (MM)								WEIGHT (LBS)
			A	B	C	ØD	ØE	ØF	ØG	H	
SL621B-6S	22000	3/8 - 1/2	6.5	12.3	20.5	1.13	2.87	6	0.75	2.2	28
SL621B-8S	16500	1/2 - 5/8	8.5	14.6	22.8	1.13	2.87	8	0.75	2.2	39
SL621B-10S	22000	5/8 - 3/4	10.2	18.1	26.4	1.13	2.87	10	0.75	2.2	55

- Blocks built to 4:1 Design Factor.
 - Blocks made with Bronze Bushed sheaves to SAE64 specifications.
 - All accessories are forged.
 - Dimensions shown represent current models and are subject to change.
 - Blocks shown are standard models.
 - Custom models available upon request.
- See our warnings & application instructions

MEDIUM WEIGHT OVAL PATTERN CONSTRUCTION BLOCK-DOUBLE SHEAVE

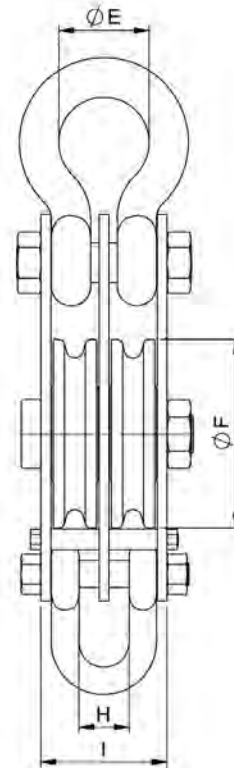
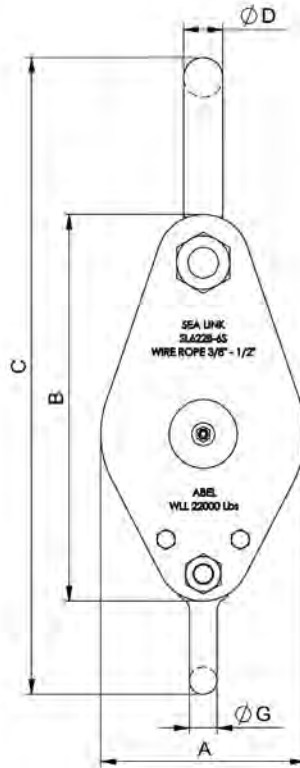

MODEL NO.	WLL LBS	WIRE ROPE ØR	DIMENSIONS (MM)									WEIGHT (LBS)
			A	B	C	ØD	ØE	ØF	ØG	H	I	
SL622B-6S	22000	3/8 - 1/2	6.5	12.3	20.5	1.25	2.87	6	0.87	1.6	4.0	44
SL622B-8S	22000	1/2 - 5/8	8.5	14.6	22.8	1.25	2.87	8	0.87	1.6	4.0	57
SL622B-10S	33000	5/8 - 3/4	10.2	18.1	26.4	1.38	2.87	10	0.87	1.6	4.0	88

- Blocks built to 4:1 Design Factor.
 - Blocks made with Bronze Bushed sheaves to SAE64 specifications.
 - All accessories are forged.
 - Dimensions shown represent current models and are subject to change.
 - Blocks shown are standard models.
 - Custom models available upon request.
- See our warnings & application instructions

MEDIUM WEIGHT OVAL PATTERN CONSTRUCTION BLOCK-TRIPLE SHEAVE

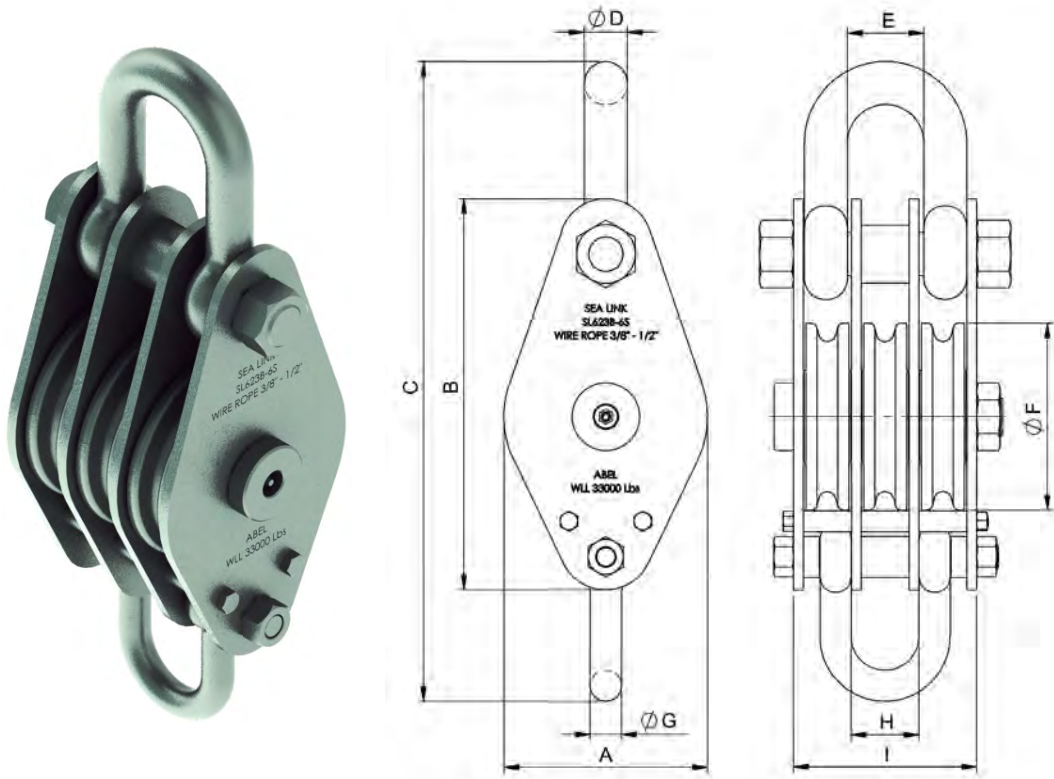

MODEL NO.	WLL LBS	WIRE ROPE ØR	DIMENSIONS (MM)									WEIGHT (LBS)
			A	B	C	ØD	E	ØF	ØG	H	I	
SL623B-6S	33000	3/8 - 1/2	6.5	12.3	20.5	1.38	2.4	6	1.0	2.2	5.9	59
SL623B-8S	33000	1/2 - 5/8	8.5	14.6	22.8	1.38	2.4	8	1.0	2.2	5.9	78
SL623B-10S	44000	5/8 - 3/4	10.2	18.1	26.4	1.5	2.2	10	1.13	2.2	5.9	120

- Blocks built to 4:1 Design Factor.
 - Blocks made with Bronze Bushed sheaves to SAE64 specifications.
 - All accessories are forged.
 - Dimensions shown represent current models and are subject to change.
 - Blocks shown are standard models.
 - Custom models available upon request.
- See our warnings & application instructions

EXTRA HEAVY OVAL PATTERN CONSTRUCTION BLOCK-SINGLE SHEAVE

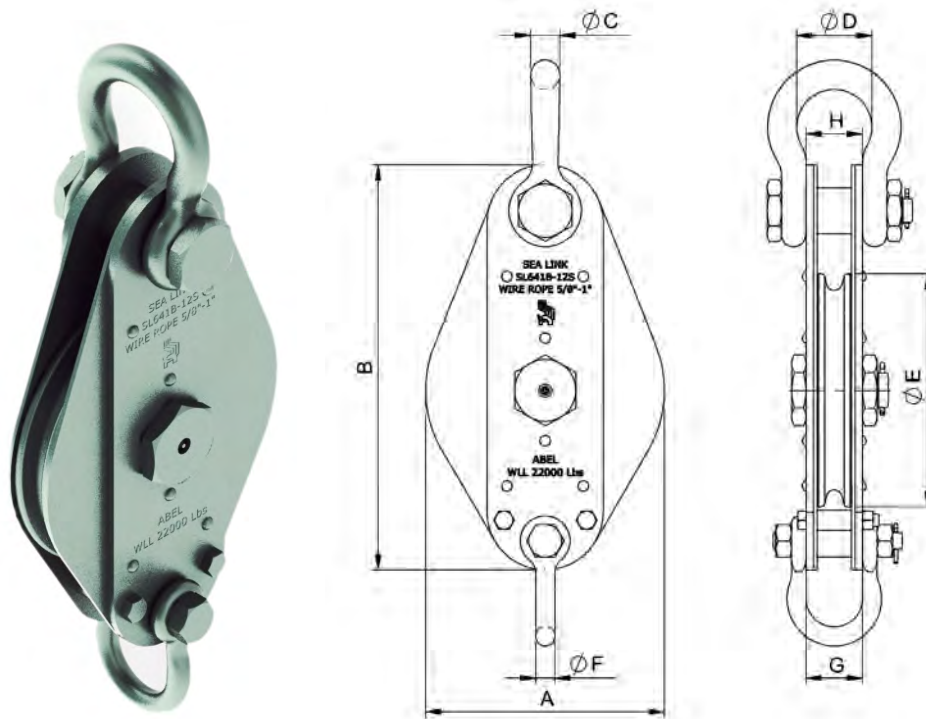

MODEL NO.	WLL LBS	WIRE ROPE ØR	DIMENSIONS (MM)								WEIGHT (LBS)
			A	B	ØC	ØD	ØE	ØF	G	H	
SL641B-8S	16500	5/8 - 3/4	8.3	14.8	1.1	2.9	8	0.75	2.5	2.5	46
SL641B-10S	22000	5/8 - 7/8	10.3	18.1	1.3	3.1	10	0.87	2.6	2.6	63
SL641B-12S	22000	5/8 - 1	12.3	20.9	1.5	3.9	12	1.0	2.9	2.9	95
SL641B-14S-22K	22000	3/4 - 7/8	14.5	24.0	1.5	3.9	14	1.12	3.5	3.5	139
SL641B-14S-30K	30000	3/4 - 1	14.5	24.0	1.5	3.9	14	1.12	3.5	3.5	139
SL641B-16S	33000	3/4 - 1	16.5	28.0	1.75	3.9	16	1.25	3.7	3.7	188

- Blocks built to 4:1 Design Factor.
 - Blocks made with Bronze Bushed sheaves to SAE64 specifications.
 - All accessories are forged.
 - Dimensions shown represent current models and are subject to change.
 - Blocks shown are standard models.
 - Custom models available upon request.
- See our warnings & application instructions

EXTRA HEAVY OVAL PATTERN CONSTRUCTION BLOCK-DOUBLE SHEAVE

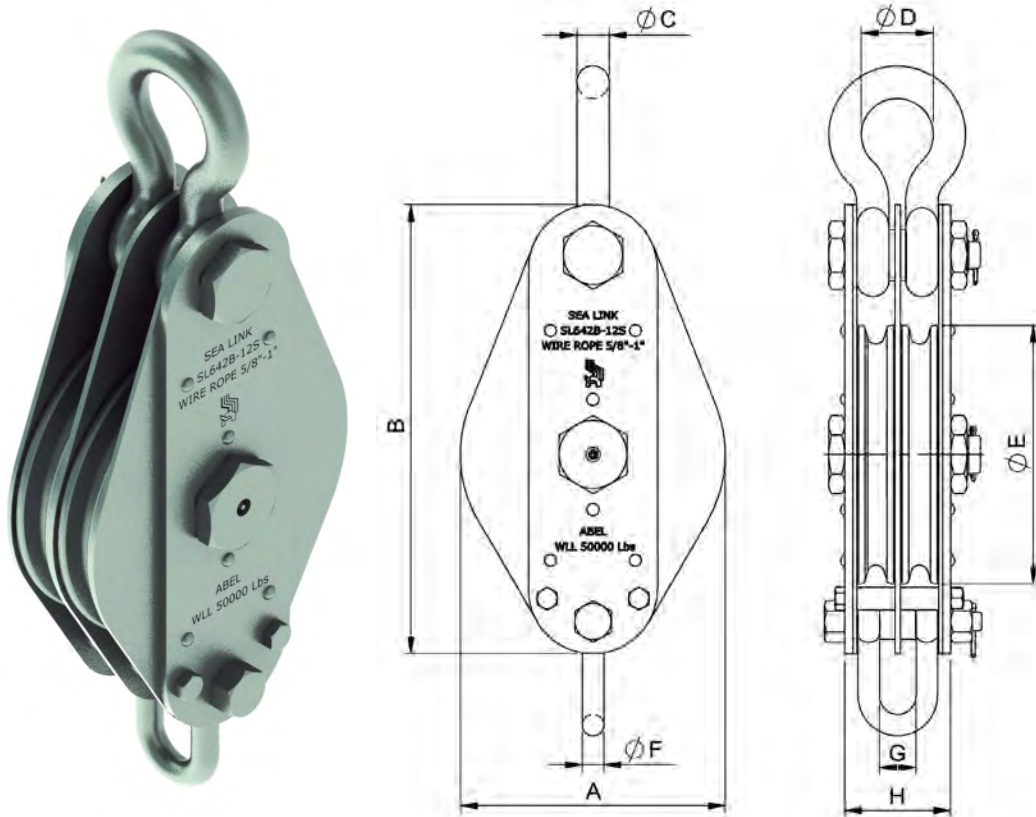

MODEL NO.	WLL LBS	WIRE ROPE ØR	DIMENSIONS (MM)								WEIGHT (LBS)
			A	B	ØC	ØD	ØE	ØF	G	H	
SL642B-8S	27500	5/8 - 3/4	8.3	14.8	1.25	2.9	8	0.87	1.7	4.4	64
SL642B-10S	44000	5/8 - 7/8	10.3	18.1	1.75	3.9	10	1.0	1.7	5.2	114
SL642B-12S	50000	5/8 - 1	12.3	20.9	1.75	3.9	12	1.12	1.6	5.2	135
SL642B-14S	50000	3/4 - 1	14.5	24.0	1.75	3.9	14	1.25	2.3	5.7	198
SL642B-16S	55000	3/4 - 1	16.5	28.0	1.75	3.9	16	1.25	3.0	6.4	205

- Blocks built to 4:1 Design Factor.
 - Blocks made with Bronze Bushed sheaves to SAE64 specifications.
 - All accessories are forged.
 - Dimensions shown represent current models and are subject to change.
 - Blocks shown are standard models.
 - Custom models available upon request.
- See our warnings & application instructions

EXTRA HEAVY OVAL PATTERN CONSTRUCTION BLOCK-TRIPLE SHEAVE

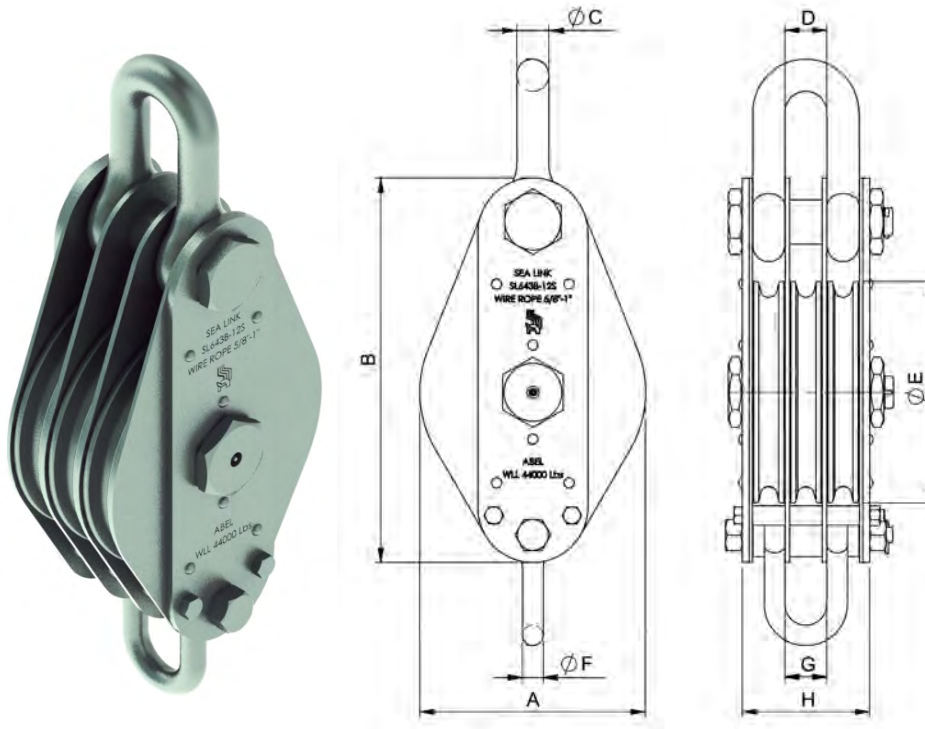

MODEL NO.	WLL LBS	WIRE ROPE	DIMENSIONS (MM)								WEIGHT (LBS)
		ØR	A	B	ØC	D	ØE	ØF	G	H	
SL643B-8S	27500	5/8 - 3/4	8.3	14.8	1.25	2.8	8	0.87	2.0	6.5	81
SL643B-10S	44000	5/8 - 7/8	10.3	18.1	1.75	2.2	10	1.12	2.3	6.9	145
SL643B-12S	44000	5/8 - 1	12.3	20.9	1.75	2.3	12	1.12	2.3	6.9	180
SL643B-14S-66K	66000	3/4 - 1	14.5	24.0	2.0	3.1	14	1.25	2.8	8.5	275
SL643B-14S-70K	70000	3/4 - 1	14.5	24.0	2.0	3.1	14	1.5	2.8	8.5	275
SL643B-16S	70000	3/4 - 1	16.5	28.0	2.0	3.9	16	1.5	3.0	9.1	345

- Blocks built to 4:1 Design Factor.
- Blocks made with Bronze Bushed sheaves to SAE64 specifications.
- All accessories are forged.
- Dimensions shown represent current models and are subject to change.
- Blocks shown are standard models.
- Custom models available upon request.

See our warnings & application instructions

REGULAR WIRE ROPE BLOCK-SINGLE SHEAVE



OBLONG SWIVEL EYE (OS)

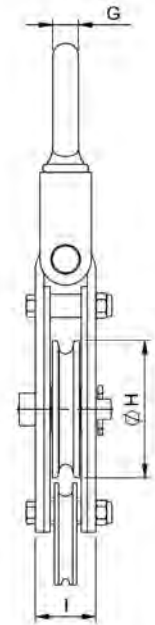
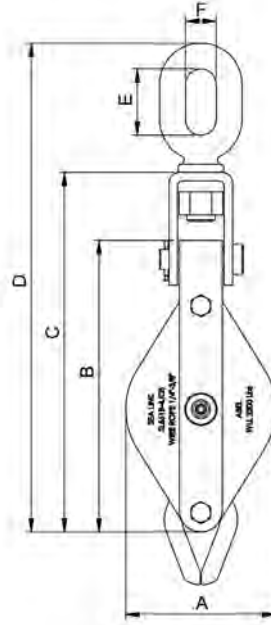

DRILLED SWIVEL EYE
AND SHACKLE (DS)



SWIVEL HOOK
(SH)



SHACKLE (S)

MODEL NO.	WLL LBS	WIRE ROPE ØR	DIMENSIONS (MM)									WEIGHT (LBS)		
			A	B	C	D	E	ØF	G	ØH	I	OS	DS	SH
												OBLONG S. EYE	DRILLED S. EYE & SHACKLE	SW. HOOK
SL661B-4	3300	1/4 - 3/8	4.3	8.5	10.6	15.0	2.4	1.1	0.75	4	1.8	9	9	9
SL661B-6	4400	1/4 - 1/2	6.3	12.6	14.6	20.5	2.6	1.3	0.87	6	2.2	17	17	17
SL661B-8	5500	3/8 - 5/8	8.3	15.7	18.5	23.6	3.0	1.4	1.0	8	2.6	25	25	25
SL661B-10	6600	1/2 - 3/4	10.2	19.3	22.4	28.5	3.2	1.5	1.12	10	3.0	53	53	53
SL661B-12	8800	5/8 - 3/4	12.4	23.2	26.4	32.5	3.2	1.5	1.26	12	3.0	66	66	66

- Blocks built to 4:1 Design Factor.
 - Blocks made with Bronze Bushed sheaves to SAE64 specifications.
 - All accessories are forged.
 - Dimensions shown represent current models and are subject to change.
 - Blocks shown are standard models.
 - Custom models available upon request.
- See our warnings & application instructions

REGULAR WIRE ROPE BLOCK-DOUBLE SHEAVE



OBLONG SWIVEL EYE (OS)

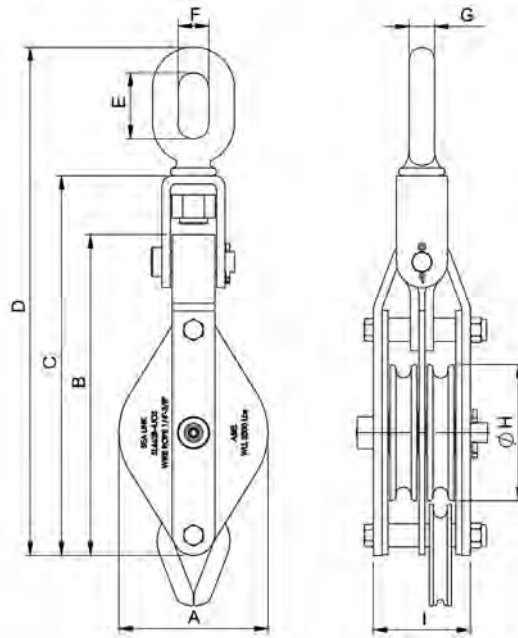

DRILLED SWIVEL EYE
AND SHACKLE (DS)



SWIVEL
HOOK (SH)



SHACKLE (S)

MODEL NO.	WLL LBS	WIRE ROPE ØR	DIMENSIONS (MM)									WEIGHT (LBS)		
			A	B	C	D	E	F	G	ØH	I	OS	DS	SH
												OBLONG S. EYE	DRILLED S. EYE & SHACKLE	SW. HOOK
SL662B-4	3300	1/4 - 3/8	4.3	8.5	10.6	15.0	2.4	1.1	0.75	4	2.8	12	12	12
SL662B-6	5500	1/4 - 1/2	6.3	12.6	14.6	20.5	2.6	1.3	0.87	6	3.6	25	25	25
SL662B-8	7700	3/8 - 5/8	8.3	15.7	18.5	23.6	3.0	1.4	1.0	8	4.3	44	44	44
SL662B-10	9900	1/2 - 3/4	10.2	19.7	22.4	28.5	3.2	1.5	1.12	10	5.0	80	80	80
SL662B-12	12100	5/8 - 3/4	12.4	23.6	26.4	32.5	3.2	1.5	1.26	12	5.0	101	101	101

- Blocks built to 4:1 Design Factor.
 - Blocks made with Bronze Bushed sheaves to SAE64 specifications.
 - All accessories are forged.
 - Dimensions shown represent current models and are subject to change.
 - Blocks shown are standard models.
 - Custom models available upon request.
- See our warnings & application instructions

REGULAR WIRE ROPE BLOCK-TRIPLE SHEAVE



OBLONG SWIVEL EYE (OS)

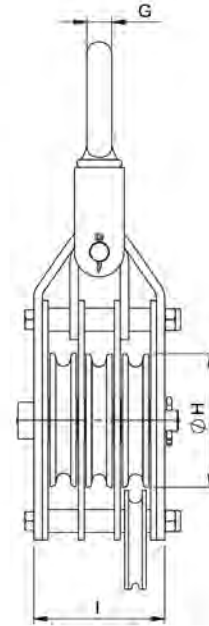
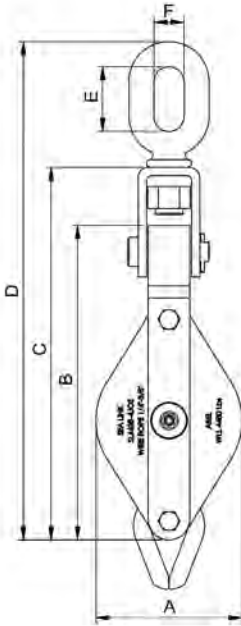

DRILLED SWIVEL EYE
AND SHACKLE (DS)



SWIVEL
HOOK (SH)



SHACKLE (S)

MODEL NO.	WLL LBS	WIRE ROPE ØR	DIMENSIONS (MM)									WEIGHT (LBS)		
			A	B	C	D	E	F	G	ØH	I	OS	DS	SH
												OBLONG S. EYE	DRILLED S. EYE & SHACKLE	SW. HOOK
SL663B-4	4400	1/4 - 3/8	4.3	9.4	10.6	15.0	2.4	1.1	0.75	4	3.9	15	15	15
SL663B-6	6600	1/4 - 1/2	6.3	12.6	14.6	20.5	2.6	1.3	0.87	6	5.1	33	33	33
SL663B-8	9900	3/8 - 5/8	8.3	15.7	18.5	23.6	3.0	1.4	1.0	8	6.1	57	57	57
SL663B-10	13200	1/2 - 3/4	10.2	19.7	22.4	28.5	3.2	1.5	1.12	10	7.0	106	106	106
SL663B-12	15400	5/8 - 3/4	12.4	23.6	26.4	32.5	3.2	1.5	1.26	12	7.0	134	134	134

- Blocks built to 4:1 Design Factor.
 - Blocks made with Bronze Bushed sheaves to SAE64 specifications.
 - All accessories are forged.
 - Dimensions shown represent current models and are subject to change.
 - Blocks shown are standard models.
 - Custom models available upon request.
- See our warnings & application instructions

INDUSTRIAL MARINE

DIAMOND STEEL SHELL WIRE ROPE BLOCK

MODEL NO.	SIZE	WORKING LOAD LIMIT (LBS)			SHEAVE DIAMETER (IN)	WIRE ROPE (IN)
		SL601	SL602	SL603		
		SINGLE	DOUBLE	TRIPLE		
SL600B-6	6	4400	5500	6600	6	3/8
SL600B-8	8	5500	7700	9900	8	1/2 - 5/8
SL600B-10	10	6600	9900	13200	10	1/2 - 5/8
SL600B-12	12	11000	22000	26600	12	3/4



SL602B-12

EXTRA HEAVY DIAMOND STEEL SHELL WIRE ROPE BLOCK

MODEL NO.	SIZE	WORKING LOAD LIMIT (LBS)			SHEAVE DIAMETER (IN)	WIRE ROPE (IN)
		SL741	SL742	SL743		
		SINGLE	DOUBLE	TRIPLE		
SL740B-8S	8	16500	22000	22000	8	1/2 - 5/8
SL740B-10S	10	22000	33000	44000	10	5/8 - 3/4
SL740B-12S	10	22000	33000	40000	12	5/8 - 3/4
SL740B-14S	12	22000	44000	88000	14	3/4 - 7/8



SL743B-12S



SL753B-14C

REEL TYPE SNATCH BLOCK

MODEL NO.	SIZE	WORKING LOAD LIMIT (LBS)	SHEAVE DIAMETER (IN)	WIRE ROPE (IN)	WEIGHT (LBS)
SL1050-Y-18	18	66000	14	3/4	301
SL1050-Y-20	20	88000	16	1	343



SL1050-Y-18

TRAWL BLOCK

MODEL NO.	SIZE	WORKING LOAD LIMIT (LBS)	SHEAVE DIAMETER (IN)	WEIGHT (LBS)
SL1030R-120S	12	22000	12	90
SL1030R-160S	16	44000	16	172



SL1030R-160S



SL1030R-16DS

ROPEBLOCK BLOCKS

- FAST REEVE CRANE BLOCKS
- STANDARD REEVE CRANE BLOCKS
- OVERHAUL BALLS
- SNATCH BLOCKS
- HIGH CAPACITY LIGHT WEIGHT (HCLW OR TILT-UP) BLOCKS
- CONSTRUCTION BLOCKS

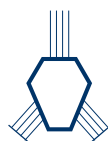
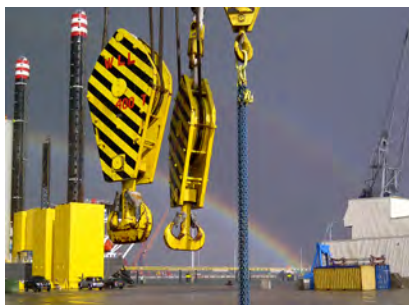

ROPEBLOCK

FAST REEVE CRANE BLOCKS

1 SHEAVE

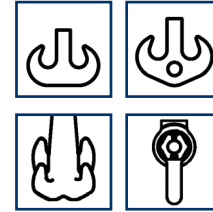
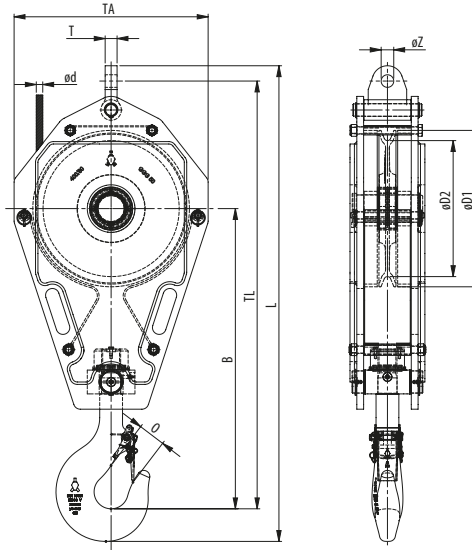

- DOUBLE HOOK
- DOUBLE HOOK WITH SHACKLE HOLE
- QUAD HOOK
- SHACKLE STUD EYE

MODEL NO.	WLL (UST)	WIRE ROPE	HOOK SIZE	DIMENSIONS (INCH)									WEIGHT (LBS)
				øD1	øD2	B	O	TA	TL	L	T	øZ	
FRB 225.xx.1.12.5.E	13.7	3/8 - 9/16	4	10.2	8.9	23.1	2.2	13.6	34	38.2	TBD	TBD	195
FRB 260.xx.1.12.5.E	13.7	7/16 - 5/8	4	11.8	10.2	25.7	2.2	15.7	36.9	41.9	TBD	TBD	220
FRB 225.xx.1.16.E	17.6	3/8 - 9/16	6	10.2	8.9	23.9	2.8	13.6	34.8	39.7	TBD	TBD	225
FRB 260.xx.1.16.E	17.6	7/16 - 5/8	6	11.8	10.2	27.3	2.8	15.7	38.5	43.4	TBD	TBD	265 325 375
FRB 285.xx.1.16.E	17.6	1/2 - 3/4	6	12.6	11.2	28.5	2.8	16.5	40.3	45.2	TBD	TBD	350
FRB 320.xx.1.16.E	17.6	9/16 - 3/4	6	14.4	12.6	28.7	2.8	17.7	41.8	46.8	TBD	TBD	350 425 475
FRB 355.xx.1.16.E	17.6	9/16 - 7/8	6	16.1	14	31	2.8	19.7	44.6	49.7	TBD	TBD	500 550
FRB 260.xx.18.2.E	20	7/16 - 5/8	5	11.8	10.2	23.3	2.2	14.4	32.1	36.7	TBD	TBD	409
FRB 225.xx.1.20.E	22	3/8 - 9/16	8	10.2	8.9	28.2	3.1	19.6	37.7	43.1	TBD	TBD	250
FRB 260.xx.1.20.E	22	7/16 - 5/8	8	11.8	10.2	29.4	3.1	15.7	40.7	46	TBD	TBD	285 375 425
FRB 285.xx.1.20.E	22	1/2 - 3/4	8	12.6	11.2	30.6	3.1	16.5	42.4	47.8	TBD	TBD	350
FRB 320.xx.1.20.E	22	9/16 - 3/4	8	14.4	12.6	30.2	3.1	17.7	43.3	48.7	TBD	TBD	350 425 475
FRB 355.xx.1.20.E	22	9/16 - 7/8	8	16.1	14	33.6	3.1	19.7	47.2	52.5	TBD	TBD	550 660
FRB 355.xx.1.25.E	27.5	9/16 - 7/8	8	16.1	14	33.4	3.1	19.7	47	52.5	TBD	TBD	550 750
FRB 400.xx.1.25.E	27.5	5/8 - 1	8	18.1	15.7	34.8	3.1	22.4	49.5	55.2	TBD	TBD	700 750
FRB 400.xx.1.26.E	28.5	5/8 - 1	8	18.1	15.7	34.8	3.1	22.4	49.5	55.2	TBD	TBD	1100
FRB 400.xx.1.29.E	32	5/8 - 1	8	18.1	15.7	34.8	3.1	22.4	49.9	55.6	TBD	TBD	800
FRB 450.xx.1.29.E	32	3/4 - 1 1/8	8	20.3	17.7	37.3	3.1	23.6	51.4	59.3	TBD	TBD	650 800
FRB 450.xx.1.32.E	35	3/4 - 1 1/8	10	20.3	17.7	39.5	3.5	23.6	56.1	62.7	TBD	TBD	1000 1100 1320
FRB 528.xx.1.32.E	35	7/8 - 1 1/4	10	23.4	20.8	40.5	3.5	28	58.7	65.3	TBD	TBD	1100 1320 1500 1800
FRB 670.xx.1.32.E	35	1 - 1 1/2	10	29.9	26.4	41.3	3.5	34.3	63.3	70.3	TBD	TBD	1700
FRB 450.xx.1.37.E	40	3/4 - 1 1/8	10	20.3	17.7	39.5	3.5	23.6	55.8	61.9	TBD	TBD	1455
FRB 528.xx.1.37.E	40	7/8 - 1 1/4	10	23.4	20.8	40.7	3.5	27.9	58.5	64.7	TBD	TBD	2270 3080

NOTE xx = To be replaced by metric wire size in final part number n TBD = These dimensions vary with wire size

- The dimensions in this table are indicative only. A drawing will always be submitted prior to production and will be the leading document when discussing dimensions.
- Blocks shown here are standard models; inquiries for custom versions are welcome.
- Refer to wire rope manufacturers D/d ratio guideline.
- Hook locking pin included on all blocks 40M ton and higher

Minimum Ultimate Strength = 4 x WLL.



ROPEBLOCK

FAST REEVE CRANE BLOCKS

1 SHEAVE

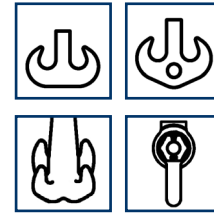
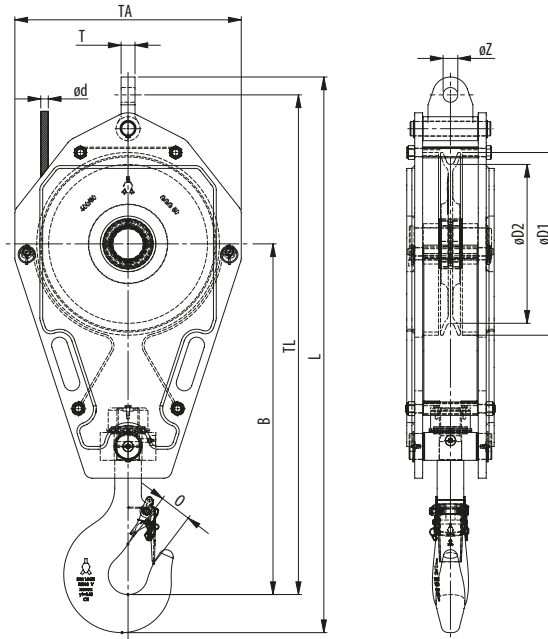

- DOUBLE HOOK
- DOUBLE HOOK WITH SHACKLE HOLE
- QUAD HOOK
- SHACKLE STUD EYE

MODEL NO.	WLL (UST)	WIRE ROPE	HOOK SIZE	DIMENSIONS (INCH)									WEIGHT (LBS)
				øD1	øD2	B	O	TA	TL	L	T	øZ	
FRB 450.xx.1.40.E	45	3/4 - 1 1/8	12	20.3	17.7	42.3	3.9	23.6	58.9	65.9	TBD	TBD	1300 1500
FRB 528.xx.1.40.E	45	7/8 - 1 1/4	12	23.4	20.8	43.9	3.9	28	62.7	69.7	TBD	TBD	1500 1700 1875 2000
FRB 450.xx.1.50.E	55	3/4 - 1 1/8	12	20.3	17.7	43.1	3.9	23.6	59.6	67.2	TBD	TBD	1300 1500
FRB 528.xx.1.50.E	55	7/8 - 1 1/4	12	23.4	20.8	43.7	3.9	28	62.6	70.1	TBD	TBD	1500 1700 1875 2000
FRB 575.xx.1.50.E	55	1 5/16 - 1 1/4	12	25.6	22.6	45	3.9	30.3	64.9	72.9	TBD	TBD	2200
FRB 630.xx.1.50.E	55	1 - 1 3/8	12	27.9	24.8	43.6	3.9	35.4	64.7	72.1	TBD	TBD	1800 3500 5300
FRB 670.xx.1.50.E	55	1 - 1 1/2	12	29.9	26.4	44.1	3.9	34.3	66.3	73.7	TBD	TBD	2000 2600 3000
FRB 670.xx.1.64.E	70	1 - 1 1/2	16	29.9	26.4	49.1	4.4	34.3	71.4	79.3	TBD	TBD	2200 2600 3000

NOTE xx = To be replaced by metric wire size in final part number n TBD = These dimensions vary with wire size

- The dimensions in this table are indicative only. A drawing will always be submitted prior to production and will be the leading document when discussing dimensions.
- Blocks shown here are standard models; inquiries for custom versions are welcome.
- Refer to wire rope manufacturers D/d ratio guideline.
- Hook locking pin included on all blocks 40M ton and higher

Minimum Ultimate Strength = 4 x WLL.



ROPEBLOCK

FAST REEVE CRANE BLOCKS

2 SHEAVES

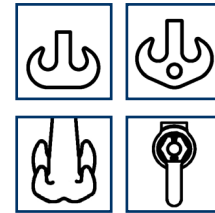
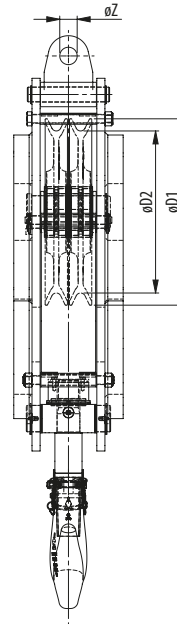
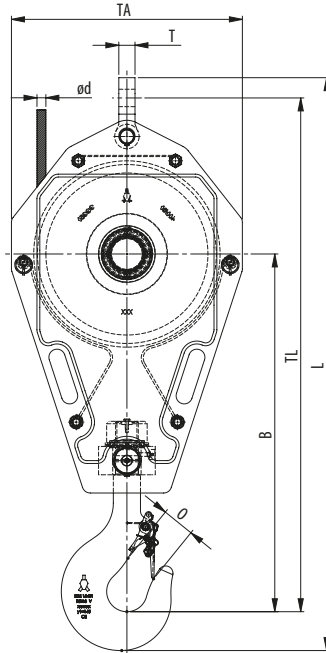

- DOUBLE HOOK
- DOUBLE HOOK WITH SHACKLE HOLE
- QUAD HOOK
- SHACKLE STUD EYE

MODEL NO.	WLL (UST)	FOR WIRE ØD INCH	HOOK SIZE	DIMENSIONS (INCH)									WEIGHT (LBS)
				ØD1	ØD2	B	O	TA	TL	L	T	ØZ	
FRB 225.xx.2.16.E	17.6	3/8 - 9/16	6	10.2	8.9	23.9	2.8	13.6	34.8	39.7	TBD	TBD	265
FRB 260.xx.2.16.E	17.6	7/16 - 5/8	6	11.8	10.2	27.3	2.8	15.7	38.5	43.4	TBD	TBD	285 350
FRB 225.xx.2.20.E	22	3/8 - 9/16	8	10.2	8.9	28.3	3.1	13.6	37.7	43.1	TBD	TBD	285
FRB 260.xx.2.20.E	22	7/16 - 5/8	8	11.8	10.2	29.4	3.1	15.7	40.7	46	TBD	TBD	285 350 425
FRB 260.xx.2.25.E	27.5	7/16 - 5/8	8	11.8	10.2	29.3	3.1	15.7	40.5	45.6	TBD	TBD	350 425
FRB 320.xx.2.25.E	27.5	9/16 - 3/4	8	14.4	12.6	30	3.1	17.7	43.1	48.5	TBD	TBD	450 495
FRB 320.xx.2.29.E	32	9/16 - 3/4	8	14.4	12.6	30.1	3.1	17.3	43.1	48.5	TBD	TBD	600
FRB 355.xx.2.29.E	32	9/16 - 7/8	8	16.1	14	33.4	3.1	19.7	47	52.5	TBD	TBD	585 625 750
FRB 400.xx.2.32.E	35	5/8 - 1	10	18.1	15.7	37.5	3.5	22.4	52.7	58.9	TBD	TBD	800
FRB 450.xx.2.32.E	35	3/4 - 1 1/8	10	20.3	17.7	39.5	3.5	23.6	55.7	61.9	TBD	TBD	1100
FRB 450.xx.2.46.E	50	3/4 - 1 1/8	12	20.3	17.7	42.2	3.9	23.6	58.5	65.2	TBD	TBD	1200 1500
FRB 450.xx.2.55.E	60	3/4 - 1 1/8	16	20.3	17.7	42.3	4.4	23.6	58.9	66.5	TBD	TBD	1600
FRB 528.xx.2.55.E	60	7/8 - 1 1/4	12	23.4	20.8	43.8	3.9	27.9	62.6	70.1	TBD	TBD	2000
FRB 670.xx.2.55.E	60	1 - 1 1/2	12	29.9	26.4	44.2	3.9	34.3	67	74.1	TBD	TBD	2080
FRB 528.xx.2.70.E	77	7/8 - 1 1/4	16	23.4	20.8	47.3	4.4	28	65.2	72.8	TBD	TBD	2200
FRB 670.xx.2.82.E	90	1 - 1 1/2	20	29.9	26.4	50.7	4.9	34.3	74.7	83.6	TBD	TBD	3400

NOTE xx = To be replaced by metric wire size in final part number n TBD = These dimensions vary with wire size

- The dimensions in this table are indicative only. A drawing will always be submitted prior to production and will be the leading document when discussing dimensions.
- Blocks shown here are standard models; inquiries for custom versions are welcome.
- Refer to wire rope manufacturers D/d ratio guideline.
- Hook locking pin included on all blocks 40M ton and higher

Minimum Ultimate Strength = 4 x WLL.



ROPEBLOCK

FAST REEVE CRANE BLOCKS

3 SHEAVES

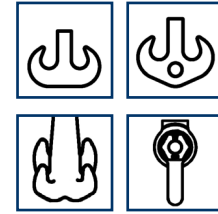
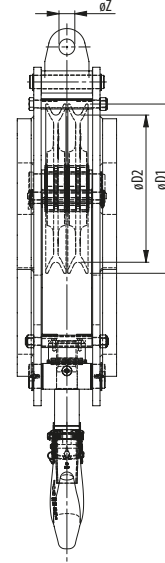
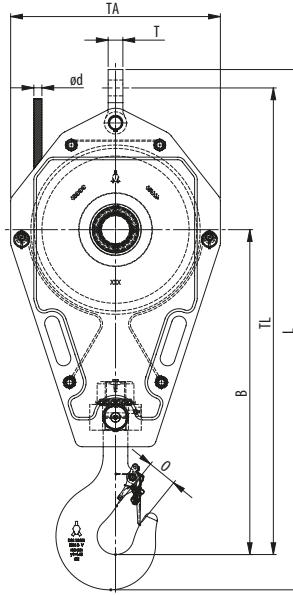

- DOUBLE HOOK
- DOUBLE HOOK WITH SHACKLE HOLE
- QUAD HOOK
- SHACKLE STUD EYE

MODEL NO.	WLL (UST)	FOR WIRE ØD INCH	HOOK SIZE	DIMENSIONS (INCH)									WEIGHT (LBS)
				ØD1	ØD2	B	O	TA	TL	L	T	ØZ	
FRB 225.xx.3.20.E	22	3/8 - 9/16	8	10.2	8.9	28.3	3.1	13.6	39.1	44.4	TBD	TBD	410
FRB 260.xx.3.20.E	22	7/16 - 5/8	8	11.8	10.2	28.5	3.1	15.7	40.1	45.4	TBD	TBD	410
FRB 260.xx.3.25.E	27.5	7/16 - 5/8	8	11.8	10.2	27.5	3.1	15.7	39.1	44.4	TBD	TBD	465
FRB 285.xx.3.29.E	32	1/2 - 3/4	8	12.6	11	27.7	3.5	16.5	39.9	45.2	TBD	TBD	460
FRB 320.xx.3.29.E	32	9/16 - 3/4	8	14.4	12.6	30	3.1	17.7	43.1	48.5	TBD	TBD	505
FRB 260.xx.3.32.E	35	7/16 - 5/8	10	11.8	10.2	28.9	3.5	15.7	40.5	46.3	TBD	TBD	465 585
FRB 285.xx.3.32.E	35	1/2 - 3/4	10	12.6	11	30	3.5	16.5	42.2	48	TBD	TBD	460 505
FRB 320.xx.3.32.E	35	9/16 - 3/4	10	14.4	12.6	32.2	3.5	17.7	45.3	51.1	TBD	TBD	505 625
FRB 320.xx.3.37.E	40	9/16 - 3/4	10	14.4	12.6	32.2	3.5	17.7	45.3	51.1	TBD	TBD	600 700
FRB 355.xx.3.37.E	40	9/16 - 7/8	10	16.1	14	34	3.5	19.7	48	53.7	TBD	TBD	700 825
FRB 360.xx.3.41.E	45	5/8 - 7/8	12	16.5	14.2	35.4	3.9	20.1	49.3	55.8	TBD	TBD	900
FRB 360.xx.3.46.E	50	5/8 - 7/8	12	16.5	14.2	35.4	3.9	20.1	49.3	55.8	TBD	TBD	900
FRB 400.xx.3.46.E	50	5/8 - 1	12	18.1	15.7	37.3	3.9	22.4	52.1	58.6	TBD	TBD	1000
FRB 360.xx.3.50.E	55	5/8 - 7/8	12	16.5	14.2	35.4	3.9	20.1	49.4	56.3	TBD	TBD	900 1200
FRB 400.xx.3.50.E	55	5/8 - 1	12	18.1	15.7	37.4	3.9	22.4	52.1	59.1	TBD	TBD	1100 1200 1350
FRB 360.xx.3.55.E	60	5/8 - 7/8	12	16.5	14.2	35.4	3.9	20.1	49.3	55.8	TBD	TBD	900 1200
FRB 400.xx.3.55.E	60	5/8 - 1	12	18.1	15.7	37.4	3.9	22.4	52.1	59.1	TBD	TBD	1100 1200 1350

NOTE xx = To be replaced by metric wire size in final part number n TBD = These dimensions vary with wire size

- The dimensions in this table are indicative only. A drawing will always be submitted prior to production and will be the leading document when discussing dimensions.
- Blocks shown here are standard models; inquiries for custom versions are welcome.
- Refer to wire rope manufacturers D/d ratio guideline.
- Hook locking pin included on all blocks 40M ton and higher

Minimum Ultimate Strength = 4 x WLL.



ROPEBLOCK

FAST REEVE CRANE BLOCKS

3 SHEAVES

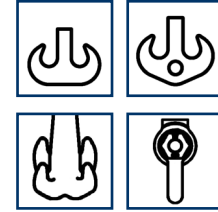
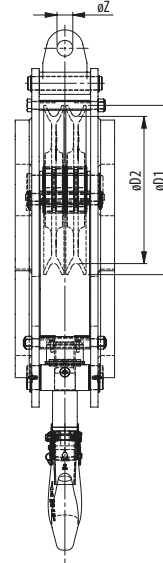
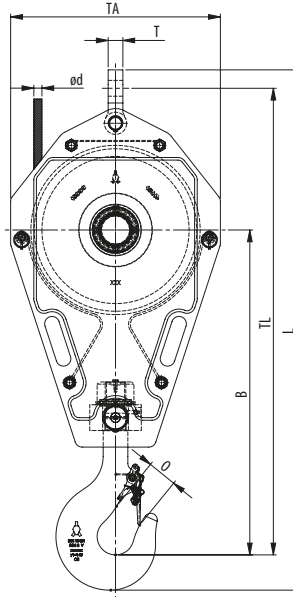

- DOUBLE HOOK
- DOUBLE HOOK WITH SHACKLE HOLE
- QUAD HOOK
- SHACKLE STUD EYE

MODEL NO.	WLL (UST)	FOR WIRE ØD INCH	HOOK SIZE	DIMENSIONS (INCH)									WEIGHT (LBS)
				ØD1	ØD2	B	O	TA	TL	L	T	ØZ	
FRB 528.xx.3.55.E	60	7/8 - 1¼	12	23.4	20.8	43.8	3.9	27.9	62.1	69.1	TBD	TBD	2300
FRB 400.xx.3.63.E	69	5/8 - 1	16	18.1	15.7	37.4	4.4	22.4	52.1	59.1	TBD	TBD	1350 2000 2100
FRB 400.xx.3.64.E	70	5/8 - 1	16	18.1	15.7	37.4	4.4	22.4	52.1	59.1	TBD	TBD	1600
FRB 450.xx.3.64.E	70	¾ - 1½	16	20.3	17.7	40.9	4.4	23.6	57.2	64.8	TBD	TBD	1500 1700
FRB 450.xx.3.70.E	77	¾ - 1½	16	20.3	17.7	41.1	4.4	23.6	57.4	64.6	TBD	TBD	1500 1700 1800
FRB 528.xx.3.70.E	77	7/8 - 1¼	16	23.4	20.8	47.6	4.4	28	65.9	73.5	TBD	TBD	2350
FRB 450.xx.3.82.E	90	¾ - 1½	20	20.3	17.7	46.5	4.9	23.6	62.8	70.7	TBD	TBD	1800 2200
FRB 630.xx.3.82.E	90	7/8 - 1¼	20	23.4	20.8	50.1	4.9	28	68.3	76.6	TBD	TBD	2500 2800
FRB 630.xx.3.82.E	90	1 - 1½	20	27.9	24.8	53.7	4.9	32.7	74.1	82.1	TBD	TBD	3600
FRB 528.xx.3.100.E	110	7/8 - 1¼	20	23.4	20.8	50.1	4.9	28	68.3	76.6	TBD	TBD	2500 2800
FRB 528.xx.3.100.E	110	7/8 - 1¼	25	23.4	20.8	53.7	5.5	28	71.9	80.9	TBD	TBD	2860 3000
FRB 575.xx.3.100.E	110	15/16 - 1¼	25	25.6	22.6	51.3	5.5	30.3	71.2	80.6	TBD	TBD	3000
FRB 575.xx.3.100.E	110	15/16 - 1¼	25	25.6	22.6	51.3	5.5	30.3	71.2	80.6	TBD	TBD	2425 4520 6620
FRB 630.xx.3.100.E	110	1 - 1½	25	27.9	24.8	53.3	5.5	32.7	74.4	83.9	TBD	TBD	2425 4520 6620
FRB 630.xx.3.100.E	110	1 - 1½	25	27.9	24.8	53.3	5.5	32.7	74.4	83.9	TBD	TBD	3500 5950
FRB 670.xx.3.100.E	110	1 - 1½	25	29.9	26.4	55.2	5.5	34.3	77.5	87	TBD	TBD	4000 14000
FRB 630.xx.3.125.E	137,5	1 - 1½	25	27.9	24.8	55.4	5.5	35.4	77.7	88	TBD	TBD	3300 12100
FRB 670.xx.3.137.E	150	1 - 1½	25	29.9	26.4	54.6	5.5	34.3	73.8	83.2	TBD	TBD	8100 16000

NOTE xx = To be replaced by metric wire size in final part number n TBD = These dimensions vary with wire size

- The dimensions in this table are indicative only. A drawing will always be submitted prior to production and will be the leading document when discussing dimensions.
- Blocks shown here are standard models; inquiries for custom versions are welcome.
- Refer to wire rope manufacturers D/d ratio guideline.
- Hook locking pin included on all blocks 40M ton and higher

Minimum Ultimate Strength = 4 x WLL.



ROPEBLOCK

FAST REEVE CRANE BLOCKS

4 SHEAVES

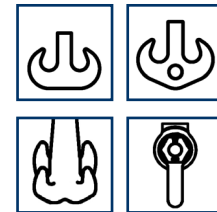
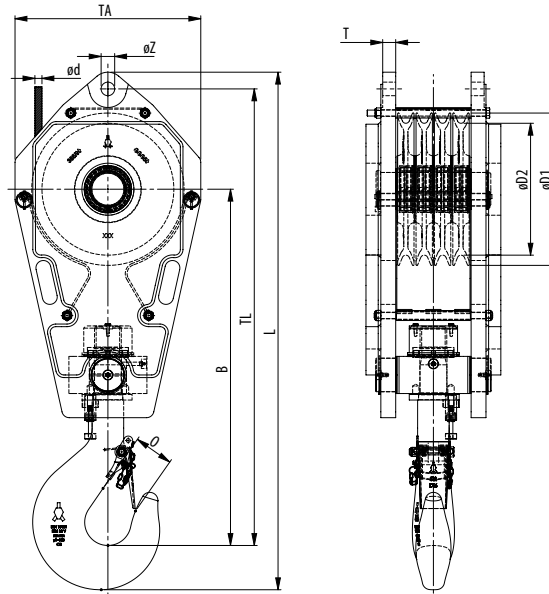

- DOUBLE HOOK
- DOUBLE HOOK WITH SHACKLE HOLE
- QUAD HOOK
- SHACKLE STUD EYE

MODEL NO.	WLL (UST)	FOR WIRE ØD INCH	HOOK SIZE	DIMENSIONS (INCH)									WEIGHT (LBS)
				ØD1	ØD2	B	O	TA	TL	L	T	ØZ	
FRB 355.xx.4.35.E	38.5	5/16 - 7/8	10	16.1	14	36.7	3.5	19.7	47.4	53.1	TBD	TBD	925
FRB 320.xx.4.37.E	40	5/16 - 3/4	10	14.4	12.6	29.6	3.5	17.7	39	44.8	TBD	TBD	700
FRB 355.xx.4.37.E	40	5/16 - 7/8	10	16.1	14	34	3.5	19.7	44.6	50.4	TBD	TBD	620
FRB 320.xx.4.41.E	45	5/16 - 3/4	12	14.4	12.6	34.6	3.9	17.7	43.9	50.2	TBD	TBD	760
FRB 355.xx.4.46.E	50	5/16 - 7/8	12	16.1	14	37.7	3.9	19.7	48.1	54.2	TBD	TBD	1000
FRB 355.xx.4.55.E	60	5/16 - 7/8	12	16.1	14	37.8	3.9	19.7	48.4	54.8	TBD	TBD	1100 1280
FRB 400.xx.4.70.E	77	5/8 - 1	16	18.1	15.7	40.9	4.4	22.4	52.5	57.7	TBD	TBD	1500
FRB 450.xx.4.70.E	77	3/4 - 1 1/8	16	20.3	17.7	40.9	4.4	23.6	57	62.2	TBD	TBD	1650 1800 1950 2400
FRB 528.xx.4.70.E	77	7/8 - 1 1/4	16	23.4	20.8	42.7	4.4	27.9	57.7	65.1	TBD	TBD	2800
FRB 528.xx.4.82.E	90	7/8 - 1 1/4	20	23.4	20.8	50.1	4.9	28	68.3	74.3	TBD	TBD	2800 2950
FRB 528.xx.4.100.E	110	7/8 - 1 1/4	25	23.4	20.8	50.7	5.5	28	68.6	75.3	TBD	TBD	2800 2950
FRB 528.xx.4.105.E	115	7/8 - 1 1/4	25	23.4	20.8	52.1	5.5	28	67.6	77.1	TBD	TBD	3850
FRB 528.xx.4.137,5.E	150	7/8 - 1 1/4	32	23.4	20.8	54.6	6.3	28	69.8	79.9	TBD	TBD	3150
FRB 575.xx.4.137,5.E	150	1 5/16 - 1 1/4	32	25.6	22.6	55.6	6.3	30.3	72.2	82.1	TBD	TBD	3000
FRB 670.xx.4.137,5.E	150	1 - 1 1/2	32	29.9	26.4	56.7	6.3	34.3	75.7	86	TBD	TBD	3200

NOTE xx = To be replaced by metric wire size in final part number n TBD = These dimensions vary with wire size

- The dimensions in this table are indicative only. A drawing will always be submitted prior to production and will be the leading document when discussing dimensions.
- Blocks shown here are standard models; inquiries for custom versions are welcome.
- Refer to wire rope manufacturers D/d ratio guideline.
- Hook locking pin included on all blocks 40M ton and higher

Minimum Ultimate Strength = 4 x WLL.



ROPEBLOCK

FAST REEVE CRANE BLOCKS

5 SHEAVES

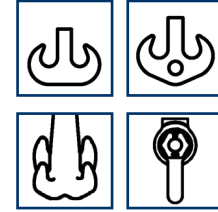
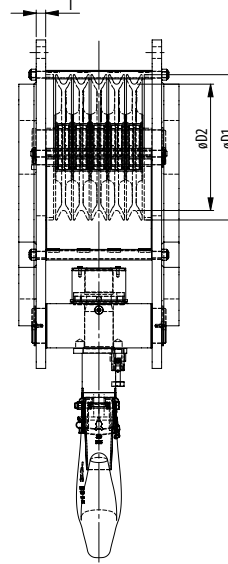
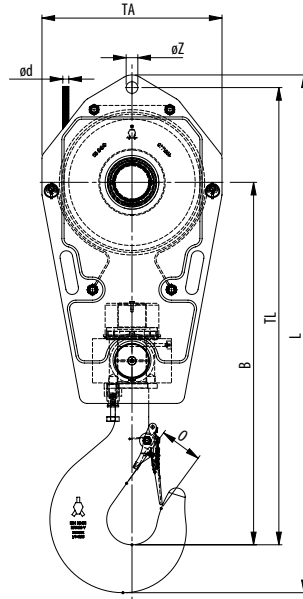

- DOUBLE HOOK
- DOUBLE HOOK WITH SHACKLE HOLE
- QUAD HOOK
- SHACKLE STUD EYE

MODEL NO.	WLL (UST)	FOR WIRE ØD INCH	HOOK SIZE	DIMENSIONS (INCH)									WEIGHT (LBS)
				ØD1	ØD2	B	O	TA	TL	L	T	ØZ	
FRB 355.xx.5.50.E	55	5/16 - 7/8	12	16.1	14	37.8	3.9	19.7	48.2	54.3	TBD	TBD	840
FRB 355.xx.5.55.E	60	5/16 - 7/8	12	16.1	14	37.8	3.9	19.7	48.2	52.8	TBD	TBD	1100 1280
FRB 360.xx.5.64.E	70	5/8 - 7/8	16	16.5	14.2	39.3	4.4	20.1	49.9	56.8	TBD	TBD	1340 1550
FRB 400.xx.5.68.E	75	5/8 - 1	16	18.1	15.7	40.2	4.4	22.4	51.8	58.6	TBD	TBD	1470 1720
FRB 360.xx.5.70.E	77	5/8 - 7/8	16	16.5	14.2	39.3	4.4	20.1	49.9	56.8	TBD	TBD	1340 1550
FRB 400.xx.5.70.E	77	5/8 - 1	16	18.1	15.7	39.8	4.4	22.4	51.4	58.4	TBD	TBD	1340
FRB 360.xx.5.72.E	80	5/8 - 7/8	16	16.5	14.2	39.6	4.4	20.1	50.2	57.1	TBD	TBD	1340 1550
FRB 400.xx.5.82.E	90	5/8 - 1	20	18.1	15.7	45.2	4.9	22.4	57	62.9	TBD	TBD	1477 1540 1600 1800
FRB 400.xx.5.91.E	100	5/8 - 1	20	18.1	15.7	45.2	4.9	22.4	57	65.2	TBD	TBD	2250
FRB 450.xx.5.91.E	100	3/4 - 1 1/8	20	20.3	17.7	46.7	4.9	23.6	59.9	67.9	TBD	TBD	2250
FRB 400.xx.5.95.E	105	5/8 - 1	20	18.1	15.7	40.7	4.9	22.4	53.1	59.9	TBD	TBD	2250 2870
FRB 400.xx.5.100.E	110	5/8 - 1	20	18.1	15.7	40.7	4.9	22.4	53.1	59.9	TBD	TBD	2250
FRB 450.xx.5.100.E	110	3/4 - 1 1/8	25	20.3	17.7	49.7	5.5	23.6	62.9	69.6	TBD	TBD	1900 2200 2250 2510
FRB 528.xx.5.100.E	110	7/8 - 1 1/4	25	23.4	20.8	49.9	5.5	28	65.9	74.6	TBD	TBD	2500 2800
FRB 528.xx.5.100.E	110	7/8 - 1 1/4	25	23.4	20.8	50.9	5.5	31.1	66	75.1	TBD	TBD	2860 3960 5060
FRB 575.xx.5.100.D	110	1 5/16 - 1 1/4	25	25.6	22.6	33.7	5.5	30.3	70.2	78.4	TBD	TBD	2860 3960 5060
FRB 528.xx.5.119.E	130	7/8 - 1 1/4	25	23.4	20.8	52.1	5.5	27.9	67.6	76.6	TBD	TBD	3300
FRB 450.xx.5.125.D	137.5	3/4 - 1 1/8	32	20.3	17.7	50.7	6.3	23.6	63.7	72.1	TBD	TBD	3630

NOTE xx = To be replaced by metric wire size in final part number n TBD = These dimensions vary with wire size

- The dimensions in this table are indicative only. A drawing will always be submitted prior to production and will be the leading document when discussing dimensions.
- Blocks shown here are standard models; inquiries for custom versions are welcome.
- Refer to wire rope manufacturers D/d ratio guideline.
- Hook locking pin included on all blocks 40M ton and higher

Minimum Ultimate Strength = 4 x WLL.



ROPEBLOCK

FAST REEVE CRANE BLOCKS

5 SHEAVES

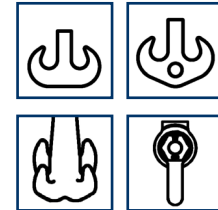
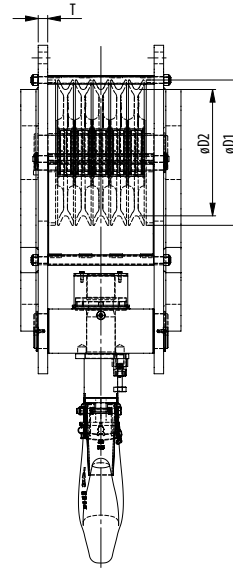
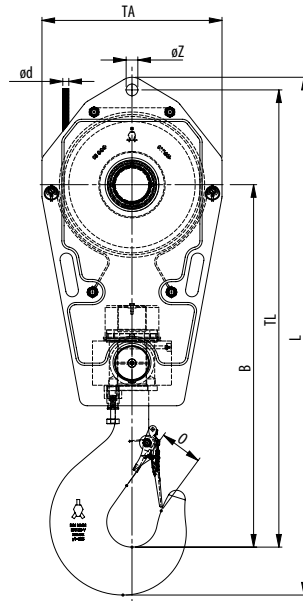

- DOUBLE HOOK
- DOUBLE HOOK WITH SHACKLE HOLE
- QUAD HOOK
- SHACKLE STUD EYE

MODEL NO.	WLL (UST)	FOR WIRE ØD INCH	HOOK SIZE	DIMENSIONS (INCH)									WEIGHT (LBS)
				ØD1	ØD2	B	O	TA	TL	L	T	ØZ	
FRB 528.xx.5.125.E	137.5	7/8 - 1¼	32	23.4	20.8	52.5	6.3	28	67.8	75.3	TBD	TBD	3500 3960
FRB 528.xx.5.129,2.E	142	7/8 - 1¼	32	23.4	20.8	56.8	6.3	27.9	71.8	81.6	TBD	TBD	5060
FRB 450.xx.5.137.D	150	¾ - 1½	32	20.3	17.7	50.8	6.3	23.6	64.6	72	TBD	TBD	3630
FRB 528.xx.5.137.E	150	7/8 - 1¼	32	23.4	20.8	54.4	6.3	28	69.8	79.7	TBD	TBD	3500
FRB 670.xx.5.137.D	150	1 - 1½	32	29.9	26.4	56.6	6.3	34.3	75.7	85.3	TBD	TBD	6000
FRB 630.xx.5.150.E	165	1 - 1¾	32	27.9	24.8	58.8	6.3	32.7	77.9	85.4	TBD	TBD	4600 6100
FRB 528.xx.5.160.E	176	7/8 - 1¼	40	23.4	20.8	59.1	7.1	28	77.9	86.3	TBD	TBD	4000 4500
FRB 575.xx.5.160.E	176	1½/16 - 1¼	40	25.6	22.6	62.6	7.1	30.3	79.2	87.5	TBD	TBD	5500
FRB 630.xx.5.160.D	176	1 - 1¾	40	27.9	24.8	57.6	7.1	32.7	75.3	85.4	TBD	TBD	5500
FRB 670.xx.5.160.E	176	1 - 1½	40	29.9	26.4	62.6	7.1	34.3	81.1	92	TBD	TBD	6000
FRB 528.xx.5.182.D	200	7/8 - 1¼	40	23.4	20.8	58.1	7.1	27.9	73.4	86.5	TBD	TBD	3860
FRB 575.xx.5.182.D	200	1½/16 - 1¼	40	25.6	22.6	62.6	7.1	30.3	79.2	90.2	TBD	TBD	5500
FRB 630.xx.5.182.E	200	1 - 1¾	40	27.9	24.8	62.3	7.1	32.7	79.4	89.8	TBD	TBD	5500 7500
FRB 670.xx.5.182.D	200	1 - 1½	40	29.9	26.4	67.6	7.1	34.3	86.9	96.1	TBD	TBD	6000
FRB 630.xx.5.200.D	220	1 - 1¾	50	27.9	24.8	63.9	7.9	35.4	86.1	96.8	TBD	TBD	5000 up to 15400

NOTE xx = To be replaced by metric wire size in final part number n TBD = These dimensions vary with wire size

- The dimensions in this table are indicative only. A drawing will always be submitted prior to production and will be the leading document when discussing dimensions.
- Blocks shown here are standard models; inquiries for custom versions are welcome.
- Refer to wire rope manufacturers D/d ratio guideline.
- Hook locking pin included on all blocks 40M ton and higher

Minimum Ultimate Strength = 4 x WLL.



ROPEBLOCK

FAST REEVE CRANE BLOCKS

6 SHEAVES

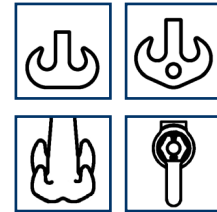
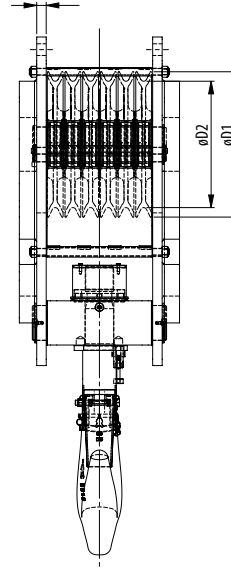
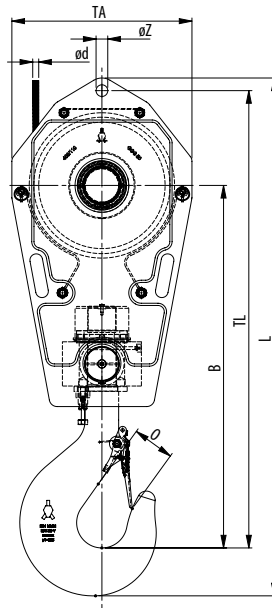

- DOUBLE HOOK
- DOUBLE HOOK WITH SHACKLE HOLE
- QUAD HOOK
- SHACKLE STUD EYE

MODEL NO.	WLL (UST)	FOR WIRE ØD INCH	HOOK SIZE	DIMENSIONS (INCH)									WEIGHT (LBS)
				ØD1	ØD2	B	O	TA	TL	L	T	ØZ	
FRB 355.xx.6.55.E	55	5/16 - 7/8	12	16.1	14	35.8	3.9	19.7	46	52.4	TBD	TBD	1496
FRB 360.xx.6.64.E	70	5/8 - 7/8	16	16.5	14.2	38.3	4.4	20.1	48.9	50.3	TBD	TBD	1495
FRB 400.xx.6.64.E	70	5/8 - 1	16	18.1	15.7	41.9	4.4	22.4	53.7	60.5	TBD	TBD	1700
FRB 400.xx.6.82.E	90	5/8 - 1	20	18.1	15.7	45.2	4.9	22.4	57	62.9	TBD	TBD	1800
FRB 450.xx.6.82.E	90	3/4 - 1 1/8	20	20.3	17.7	46.7	4.9	23.6	62.2	68.1	TBD	TBD	2000
FRB 400.xx.6.91.E	100	5/8 - 1	20	18.1	15.7	44.6	4.9	22.4	56.4	64	TBD	TBD	1750 1800 2200
FRB 450.xx.6.100.E	110	3/4 - 1 1/8	25	20.3	17.7	49.7	5.5	23.6	62.9	69.6	TBD	TBD	2500
FRB 528.xx.6.100.E	110	7/8 - 1 1/4	25	23.4	20.8	50.1	5.5	28	64.9	73.4	TBD	TBD	2500
FRB 450.xx.6.120.E	132	3/4 - 1 1/8	25	20.3	17.7	47.9	5.5	22.4	59.8	68.1	TBD	TBD	2200
FRB 528.xx.6.137.E	150	7/8 - 1 1/4	32	23.4	20.8	52.5	6.3	28	67.8	77.8	TBD	TBD	3500
FRB 528.xx.6.150.E	165	7/8 - 1 1/4	40	23.5	20.8	61.1	7.1	28	79.5	87.9	TBD	TBD	4000
FRB 528.xx.6.160.E	176	7/8 - 1 1/4	40	23.5	20.8	62.2	7.1	28	77.8	86.1	TBD	TBD	4500 5000
FRB 528.xx.6.182.E	200	7/8 - 1 1/4	40	23.5	20.8	63	7.1	28	79.5	87.9	TBD	TBD	4500
FRB 575.xx.6.182.E	200	1 1/16 - 1 1/4	40	25.6	22.6	61.1	7.1	30.3	77.4	88.4	TBD	TBD	4500 5500
FRB 670.xx.6.182.E	200	1 - 1 1/2	40	29.9	26.4	61.7	7.1	34.3	80.2	90.2	TBD	TBD	5500
FRB 528.xx.6.200.E	220	7/8 - 1 1/4	50	23.5	20.8	63	7.9	28	79.5	87.9	TBD	TBD	5500
FRB 575.xx.6.209.E	230	1 1/16 - 1 1/4	50	25.6	22.6	65.4	7.9	30.3	81.9	91.2	TBD	TBD	6500

NOTE xx = To be replaced by metric wire size in final part number n TBD = These dimensions vary with wire size

- The dimensions in this table are indicative only. A drawing will always be submitted prior to production and will be the leading document when discussing dimensions.
- Blocks shown here are standard models; inquiries for custom versions are welcome.
- Refer to wire rope manufacturers D/d ratio guideline.
- Hook locking pin included on all blocks 40M ton and higher

Minimum Ultimate Strength = 4 x WLL.



ROPEBLOCK

FAST REEVE CRANE BLOCKS

7 SHEAVES

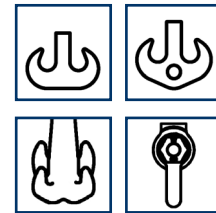
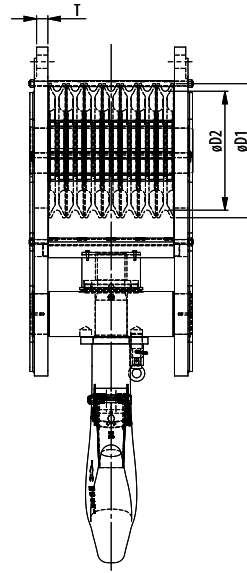
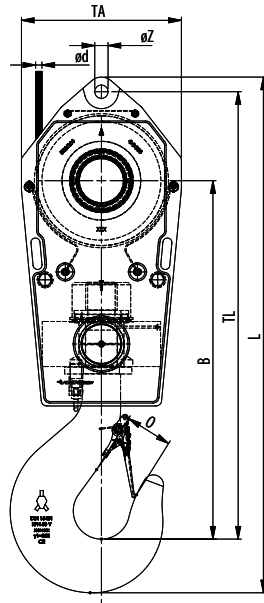

- DOUBLE HOOK
- DOUBLE HOOK WITH SHACKLE HOLE
- QUAD HOOK
- SHACKLE STUD EYE

MODEL NO.	WLL (UST)	FOR WIRE ØD INCH	HOOK SIZE	DIMENSIONS (INCH)									WEIGHT (LBS)
				ØD1	ØD2	B	O	TA	TL	L	T	ØZ	
FRB 355.xx.7.75.E	82.5	5/16 - 7/8	16	16.1	14	39.2	4.4	18.9	49.8	56.8	TBD	TBD	1600
FRB 400.xx.7.100.E	110	5/8 - 1	20	18.1	15.7	43.6	4.9	22.4	55.6	63.4	TBD	TBD	2400
FRB 400.xx.7.118.E	130	5/8 - 1	25	18.1	15.7	48.9	5.5	22.4	60.9	69.4	TBD	TBD	2400
FRB 400.xx.7.127.D	140	5/8 - 1	32	18.1	15.7	47.8	6.3	22.4	59.8	68.3	TBD	TBD	2850
FRB 450.xx.7.127.E	140	3/4 - 1 1/8	32	20.3	17.7	54.3	6.3	23.6	67.4	76.9	TBD	TBD	3150
FRB 450.xx.7.137.E	150	3/4 - 1 1/8	32	20.3	17.7	54.3	6.3	23.6	67.4	76.9	TBD	TBD	3100
FRB 450.xx.7.160.D	176	3/4 - 1 1/8	40	20.3	17.7	58.2	7.1	23.6	71.4	80.8	TBD	TBD	3930
FRB 528.xx.7.160.D	176	7/8 - 1 1/4	40	23.4	20.8	58.6	7.1	31.1	73.9	83.5	TBD	TBD	3300 4950 6600
FRB 528.xx.5.171.D	188	7/8 - 1 1/4	40	23.4	20.8	55.9	7.1	31.1	71.1	81	TBD	TBD	5940
FRB 575.xx.7.171.D	188	1 5/16 - 1 1/4	40	25.6	22.6	56.8	7.1	30.4	72.7	82.6	TBD	TBD	5940
FRB 528.xx.7.182.E	200	7/8 - 1 1/4	40	23.4	20.8	59.5	7.1	27.9	74.3	85.4	TBD	TBD	6160
FRB 528.xx.7.200.D	220	7/8 - 1 1/4	50	23.4	20.8	58.8	7.9	27.9	74.3	84.2	TBD	TBD	5280
FRB 575.xx.7.209.D	230	1 5/16 - 1 1/4	50	25.6	22.6	59.9	7.9	30.3	76.4	87.4	TBD	TBD	6500 7500
FRB 575.xx.7.209.D	230	1 5/16 - 1 1/4	50	25.6	22.6	59.9	7.9	30.3	76.4	87.5	TBD	TBD	5500 7500 8500
FRB 575.xx.7.209.D	230	1 5/16 - 1 1/4	50	25.6	22.6	59.9	7.9	30.3	76.4	87.5	TBD	TBD	5500 7500 9500
FRB 630.xx.7.209.D	230	1 - 1 3/8	50	27.9	24.8	60.8	7.9	32.6	78.4	89.6	TBD	TBD	5500 7500 9500
FRB 670.xx.7.209.D	230	1 - 1 1/2	50	29.9	26.4	63.1	7.9	34.3	82.2	93.1	TBD	TBD	6500 9500
FRB 670.xx.7.228.D	250	1 - 1 1/2	50	29.9	26.4	63.1	7.9	34.3	82.2	93.1	TBD	TBD	6500 7700
FRB 670.xx.7.250.DB	275	1 - 1 1/2	63	29.9	26.4	64.6	8.8	34.3	83.8	99.5	TBD	TBD	10000
FRB 528.xx.7.272.D	300	7/8 - 1 1/4	63	23.4	20.8	61.8	8.8	27.9	77.2	88.8	TBD	TBD	6450

NOTE xx = To be replaced by metric wire size in final part number • TBD = These dimensions vary with wire size

- The dimensions in this table are indicative only. A drawing will always be submitted prior to production and will be the leading document when discussing dimensions.
- Blocks shown here are standard models; inquiries for custom versions are welcome.
- Refer to wire rope manufacturers D/d ratio guideline.
- Hook locking pin included on all blocks 40M ton and higher

Minimum Ultimate Strength = 4 x WLL.



ROPEBLOCK

STANDARD REEVE CRANE BLOCKS

1 SHEAVE

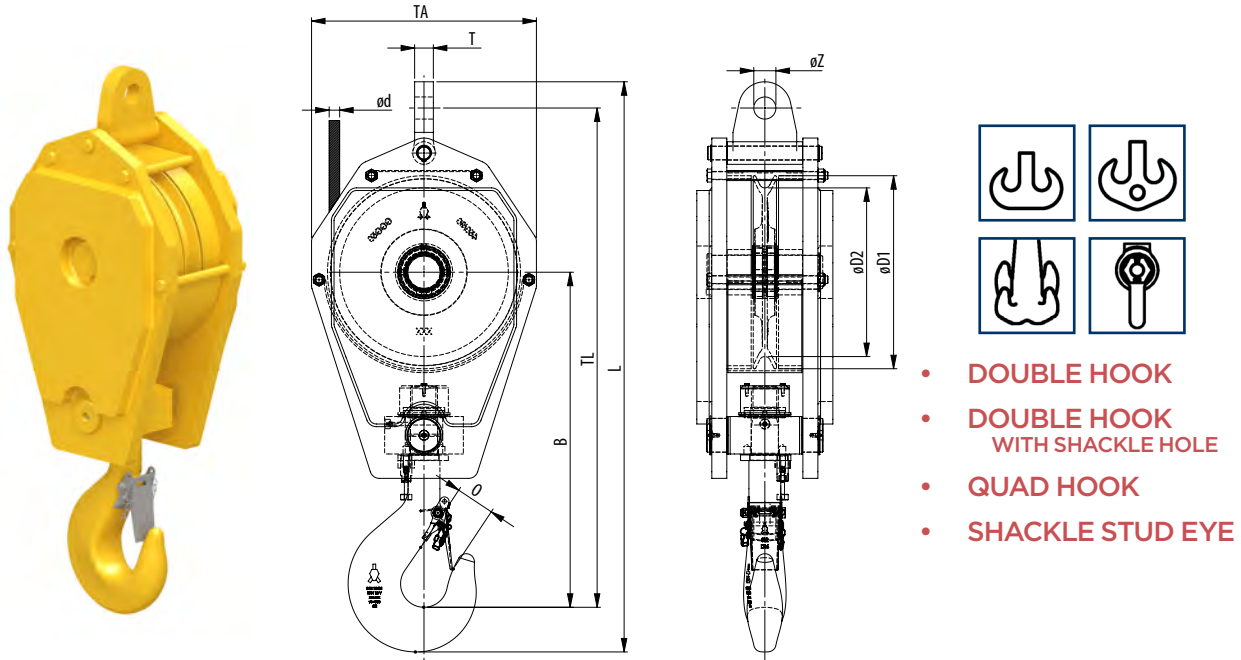

- DOUBLE HOOK
- DOUBLE HOOK WITH SHACKLE HOLE
- QUAD HOOK
- SHACKLE STUD EYE

MODEL NO.	WLL (UST)	FOR WIRE ØD INCH	HOOK SIZE	DIMENSIONS (INCH)									WEIGHT (LBS)
				ØD1	ØD2	B	O	TA	TL	L	T	ØZ	
SRB 225.xx.1.12.5.E	13.7	3/8 - 9/16	5	10.2	8.9	20.6	2.5	13.6	31.4	35.9	TBD	TBD	165
SRB 260.xx.1.12.5.E	13.7	7/16 - 5/8	5	11.8	10.2	21.6	2.5	15.7	32.8	37.3	TBD	TBD	240
SRB 225.xx.1.16.E	17.6	3/8 - 9/16	6	10.2	8.9	21.6	2.5	13.6	32.4	36.9	TBD	TBD	220
SRB 260.xx.1.16.E	17.6	7/16 - 5/8	6	11.8	10.2	21.6	2.5	15.7	32.8	37.3	TBD	TBD	240
SRB 285.xx.1.16.E	17.6	1/2 - 3/4	6	12.6	11	23.9	2.8	16.5	35.7	40.7	TBD	TBD	350
SRB 320.xx.1.16.E	17.6	9/16 - 3/4	6	14.4	12.6	24.7	2.8	17.7	37.4	42.6	TBD	TBD	350
SRB 355.xx.1.16.E	17.6	9/16 - 7/8	6	16.1	14	26.3	2.8	19.7	39.9	44.8	TBD	TBD	400
SRB 320.xx.1.20.E	22	9/16 - 3/4	8	14.4	12.6	27.1	3.1	17.7	39.8	45.4	TBD	TBD	350
SRB 355.xx.1.20.E	22	9/16 - 7/8	8	16.1	14	28.1	3.1	19.7	41.5	47.4	TBD	TBD	550
SRB 450.xx.1.25.E	27.5	3/4 - 1 1/8	8	20.3	17.7	30.3	3.1	23.6	46.8	52.9	TBD	TBD	435
SRB 528.xx.1.28.E	30	7/8 - 1 1/4	8	23.5	20.8	33	3.1	27.9	52	58.6	TBD	TBD	600
SRB 400.xx.1.29.E	32	5/8 - 1	8	18.1	15.7	29.3	3.1	22.4	44.4	50.1	TBD	TBD	640
SRB 450.xx.1.32.E	35	3/4 - 1 1/8	10	20.3	17.7	32.8	3.5	23.6	49.4	56	TBD	TBD	1000 1100
SRB 528.xx.1.32.E	35	7/8 - 1 1/4	10	23.5	20.8	35.4	3.5	28	53.6	60.2	TBD	TBD	1100 1400 2000
SRB 450.xx.1.40.E	45	3/4 - 1 1/8	12	20.3	17.7	42.3	3.9	23.6	58.5	65.6	TBD	TBD	1300
SRB 450.xx.1.50.E	55	3/4 - 1 1/8	12	20.3	17.7	36.1	3.9	23.8	52.7	59.7	TBD	TBD	1300
SRB 528.xx.1.50.E	55	7/8 - 1 1/4	12	23.5	20.8	36.8	3.9	28	55.6	63.1	TBD	TBD	1650
SRB 575.xx.1.50.E	55	1 5/16 - 1 1/4	12	25.6	22.6	37.7	3.9	30.3	57.4	65.4	TBD	TBD	2045
SRB 630.xx.1.64.E	70	1 - 1 3/8	16	28.3	24.8	38.8	4.4	32.5	59.9	68	TBD	TBD	2200
SRB 670.xx.1.64.E	70	1 - 1 1/2	16	29.9	26.4	46.2	4.4	34.3	68.4	76.6	TBD	TBD	3000

NOTE xx = To be replaced by metric wire size in final part number n TBD = These dimensions vary with wire size

- The dimensions in this table are indicative only. A drawing will always be submitted prior to production and will be the leading document when discussing dimensions.
- Blocks shown here are standard models; inquiries for custom versions are welcome.
- Refer to wire rope manufacturers D/d ratio guideline.
- Hook locking pin included on all blocks 40M ton and higher

Minimum Ultimate Strength = 4 x WLL.

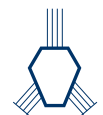

ROPEBLOCK

STANDARD REEVE CRANE BLOCKS

2 SHEAVES

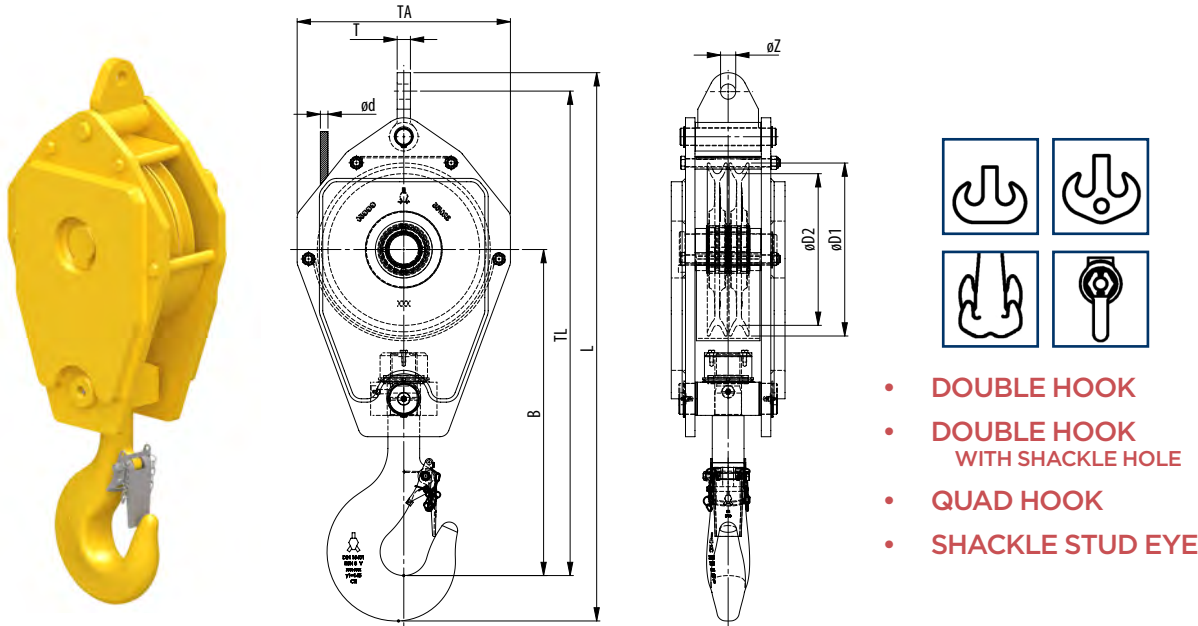

- DOUBLE HOOK
- DOUBLE HOOK WITH SHACKLE HOLE
- QUAD HOOK
- SHACKLE STUD EYE

MODEL NO.	WLL (UST)	FOR WIRE ØD INCH	HOOK SIZE	DIMENSIONS (INCH)									WEIGHT (LBS)
				ØD1	ØD2	B	O	TA	TL	L	T	ØZ	
SRB 225.xx.2.16.E	17.6	3/8 - 9/16	6	11.8	10.2	23.3	2.8	15.7	34.6	39.5	TBD	TBD	240
SRB 260.xx.2.16.E	17.6	7/16 - 5/8	6	11.8	10.2	23.3	2.8	15.7	34.6	39.5	TBD	TBD	285 350
SRB 285.xx.2.16.E	17.6	1/2 - 3/4	6	12.6	11	23.9	2.8	16.5	35.7	40.7	TBD	TBD	210
SRB 260.xx.2.20.E	22	7/16 - 5/8	8	11.8	10.2	26.7	3.1	15.7	43	38	TBD	TBD	285 350
SRB 285.xx.2.20.E	22	1/2 - 3/4	8	12.6	11	26.3	3.1	16.5	38.1	43.4	TBD	TBD	285 330
SRB 320.xx.2.20.E	22	9/16 - 3/4	8	14.4	12.6	27.1	3.1	17.7	39.8	45.1	TBD	TBD	350
SRB 320.xx.2.22.E	24	9/16 - 3/4	8	14.4	12.6	27.1	3.1	17.7	39.8	45.6	TBD	TBD	350
SRB 260.xx.2.25.E	27.5	7/16 - 5/8	8	11.8	10.2	26.5	3.1	15.7	37.7	42.8	TBD	TBD	350
SRB 320.xx.2.25.E	27.5	9/16 - 3/4	8	14.4	12.6	27.1	3.1	17.7	39.8	45.1	TBD	TBD	450
SRB 355.xx.2.29.E	32	9/16 - 7/8	8	16.1	14	28.1	3.1	19.7	41.9	47.4	TBD	TBD	550
SRB 400.xx.2.29.E	32	5/8 - 1	8	18.1	15.7	29.3	3.1	22.4	44.4	50.1	TBD	TBD	705
SRB 450.xx.2.40.E	45	3/4 - 1 1/8	12	20.3	17.7	35.2	3.9	23.6	52	58.1	TBD	TBD	1210
SRB 450.xx.2.50.E	55	3/4 - 1 1/8	12	20.3	17.7	35.2	3.9	23.6	52	59.6	TBD	TBD	1210
SRB 400.xx.2.55.E	60	5/8 - 1	12	18.1	15.7	34	3.9	22.4	48.9	55.6	TBD	TBD	800
SRB 528.xx.2.64.E	70	7/8 - 1 1/4	16	23.4	20.8	39.5	4.4	28	58.4	65.9	TBD	TBD	2155
SRB 528.xx.2.80.E	88	7/8 - 1 1/4	20	23.4	20.8	43.7	4.9	28	62.6	71.2	TBD	TBD	2200
SRB 670.xx.2.100.E	110	1 - 1 3/8	20	29.9	26.4	49.5	4.9	34.3	71.7	80.4	TBD	TBD	4930

NOTE xx = To be replaced by metric wire size in final part number • TBD = These dimensions vary with wire size

- The dimensions in this table are indicative only. A drawing will always be submitted prior to production and will be the leading document when discussing dimensions.
- Blocks shown here are standard models; inquiries for custom versions are welcome.
- Refer to wire rope manufacturers D/d ratio guideline.
- Hook locking pin included on all blocks 40M ton and higher

Minimum Ultimate Strength = 4 x WLL.



ROPEBLOCK

STANDARD REEVE CRANE BLOCKS

3 SHEAVES

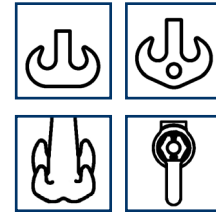
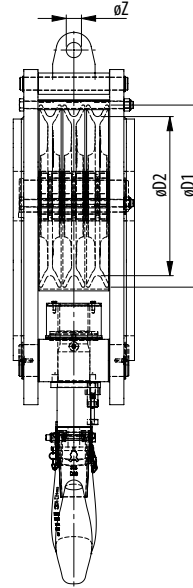
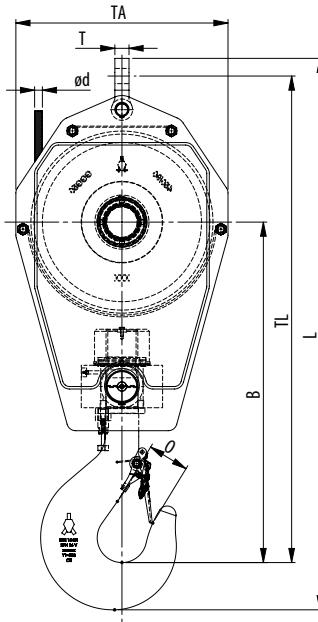

- DOUBLE HOOK
- DOUBLE HOOK WITH SHACKLE HOLE
- QUAD HOOK
- SHACKLE STUD EYE

MODEL NO.	WLL (UST)	FOR WIRE ØD INCH	HOOK SIZE	DIMENSIONS (INCH)									WEIGHT (LBS)
				ØD1	ØD2	B	O	TA	TL	L	T	ØZ	
SRB 225.xx.1.12,5.E	13.7	3/8 - 9/16	5	10.2	8.9	20.6	2.5	13.6	31.4	35.9	TBD	TBD	165
SRB 260.xx.1.12,5.E	13.7	7/16 - 5/8	5	11.8	10.2	21.6	2.5	15.7	32.8	37.3	TBD	TBD	240
SRB 225.xx.1.16.E	17.6	3/8 - 9/16	6	10.2	8.9	21.6	2.5	13.6	32.4	36.9	TBD	TBD	220
SRB 260.xx.1.16.E	17.6	7/16 - 5/8	6	11.8	10.2	21.6	2.5	15.7	32.8	37.3	TBD	TBD	240
SRB 285.xx.1.16.E	17.6	1/2 - 3/4	6	12.6	11	23.9	2.8	16.5	35.7	40.7	TBD	TBD	350
SRB 320.xx.1.16.E	17.6	9/16 - 3/4	6	14.4	12.6	24.7	2.8	17.7	37.4	42.6	TBD	TBD	350
SRB 355.xx.1.16.E	17.6	9/16 - 7/8	6	16.1	14	26.3	2.8	19.7	39.9	44.8	TBD	TBD	400
SRB 320.xx.1.20.E	22	9/16 - 3/4	8	14.4	12.6	27.1	3.1	17.7	39.8	45.4	TBD	TBD	350
SRB 355.xx.1.20.E	22	9/16 - 7/8	8	16.1	14	28.1	3.1	19.7	41.5	47.4	TBD	TBD	550
SRB 450.xx.1.25.E	27.5	3/4 - 1 1/8	8	20.3	17.7	30.3	3.1	23.6	46.8	52.9	TBD	TBD	435
SRB 528.xx.1.28.E	30	7/8 - 1 1/4	8	23.5	20.8	33	3.1	27.9	52	58.6	TBD	TBD	600
SRB 400.xx.1.29.E	32	5/8 - 1	8	18.1	15.7	29.3	3.1	22.4	44.4	50.1	TBD	TBD	640
SRB 450.xx.1.32.E	35	3/4 - 1 1/8	10	20.3	17.7	32.8	3.5	23.6	49.4	56	TBD	TBD	1000 1100
SRB 528.xx.1.32.E	35	7/8 - 1 1/4	10	23.5	20.8	35.4	3.5	28	53.6	60.2	TBD	TBD	1100 1400 2000
SRB 450.xx.1.40.E	45	3/4 - 1 1/8	12	20.3	17.7	42.3	3.9	23.6	58.5	65.6	TBD	TBD	1300
SRB 450.xx.1.50.E	55	3/4 - 1 1/8	12	20.3	17.7	36.1	3.9	23.8	52.7	59.7	TBD	TBD	1300
SRB 528.xx.1.50.E	55	7/8 - 1 1/4	12	23.5	20.8	36.8	3.9	28	55.6	63.1	TBD	TBD	1650
SRB 575.xx.1.50.E	55	1 5/16 - 1 1/4	12	25.6	22.6	37.7	3.9	30.3	57.4	65.4	TBD	TBD	2045
SRB 630.xx.1.64.E	70	1 - 1 3/8	16	28.3	24.8	38.8	4.4	32.5	59.9	68	TBD	TBD	2200
SRB 670.xx.1.64.E	70	1 - 1 1/2	16	29.9	26.4	46.2	4.4	34.3	68.4	76.6	TBD	TBD	3000

NOTE xx = To be replaced by metric wire size in final part number n TBD = These dimensions vary with wire size

- The dimensions in this table are indicative only. A drawing will always be submitted prior to production and will be the leading document when discussing dimensions.
- Blocks shown here are standard models; inquiries for custom versions are welcome.
- Refer to wire rope manufacturers D/d ratio guideline.
- Hook locking pin included on all blocks 40M ton and higher

Minimum Ultimate Strength = 4 x WLL.



ROPEBLOCK

STANDARD REEVE CRANE BLOCKS

4 SHEAVES

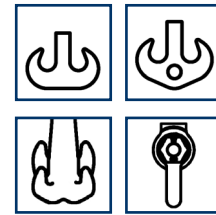
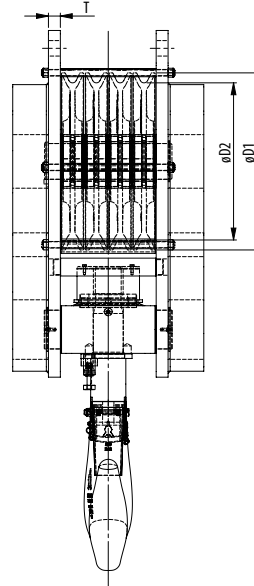
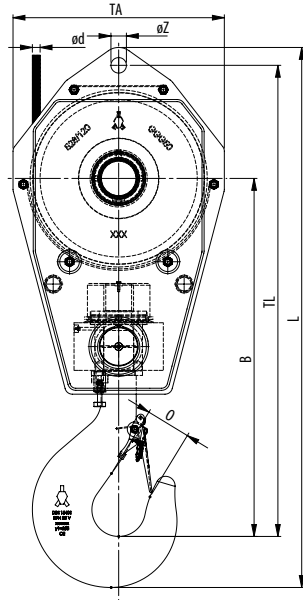

- DOUBLE HOOK
- DOUBLE HOOK WITH SHACKLE HOLE
- QUAD HOOK
- SHACKLE STUD EYE

MODEL NO.	WLL (UST)	FOR WIRE ØD INCH	HOOK SIZE	DIMENSIONS (INCH)									WEIGHT (LBS)
				ØD1	ØD2	B	O	TA	TL	L	T	ØZ	
SRB 285.xx.4.35.E	38.5	½ - ¾	10	12.8	11.2	26	3.5	15.7	36.2	40.4	TBD	TBD	570
SRB 355.xx.4.50.E	55	⅝ - ⅞	12	16.1	14	33	3.9	19.7	43.9	50.8	TBD	TBD	1045
SRB 528.xx.4.55.E	60	⅞ - 1¼	12	23.5	20.8	38.5	3.9	28	53.5	60.6	TBD	TBD	2600
SRB 400.xx.4.64.E	70	⅝ - 1	16	18.1	15.7	35.6	4.4	22.4	47.2	54.4	TBD	TBD	1155
SRB 450.xx.4.64.E	70	¾ - 1⅛	16	20.3	17.7	38	4.4	23.6	52	59.2	TBD	TBD	1595
SRB 528.xx.4.70.E	77	⅞ - 1¼	16	23.5	20.8	40.4	4.4	28	55.3	63	TBD	TBD	3850
SRB 528.xx.4.73.E	80	⅞ - 1¼	16	23.5	20.8	40.4	4.4	28	55.3	63	TBD	TBD	2850
SRB 450.xx.4.82.E	90	¾ - 1⅛	20	20.3	17.7	41.2	4.9	23.6	51.6	59.8	TBD	TBD	2110
SRB 450.xx.4.82.E	90	¾ - 1⅛	20	20.3	17.7	41.2	4.9	23.6	51.6	59.8	TBD	TBD	2110
SRB 528.xx.4.105.E	115	⅞ - 1¼	25	23.4	20.8	48.1	5.5	28	62.7	71.8	TBD	TBD	3900
SRB 710.xx.4.105.E	115	1⅛ - 1½	25	31.5	28	53.3	5.5	35.4	73.9	84.4	TBD	TBD	3000
SRB 450.xx.4.108.E	120	¾ - 1⅛	25	20.3	17.7	46.8	5.5	23.6	60.2	68.9	TBD	TBD	3200
SRB 670.xx.4.160.E	176	1 - 1⅝	40	29.9	26.4	60.7	7.1	34.3	82.9	94	TBD	TBD	6930

NOTE xx = To be replaced by metric wire size in final part number n TBD = These dimensions vary with wire size

- The dimensions in this table are indicative only. A drawing will always be submitted prior to production and will be the leading document when discussing dimensions.
- Blocks shown here are standard models; inquiries for custom versions are welcome.
- Refer to wire rope manufacturers D/d ratio guideline.
- Hook locking pin included on all blocks 40M ton and higher

Minimum Ultimate Strength = 4 x WLL.



ROPEBLOCK

STANDARD REEVE CRANE BLOCKS

5 SHEAVES

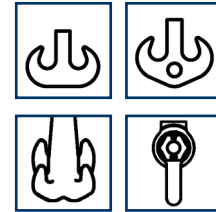
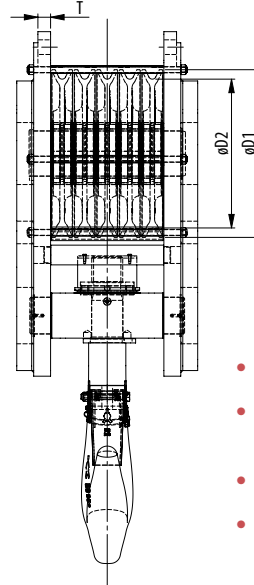
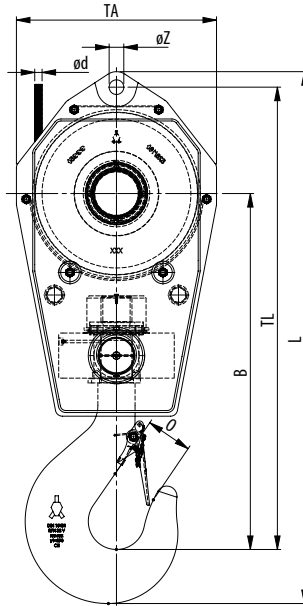

- DOUBLE HOOK
- DOUBLE HOOK WITH SHACKLE HOLE
- QUAD HOOK
- SHACKLE STUD EYE

MODEL NO.	WLL (UST)	FOR WIRE ØD INCH	HOOK SIZE	DIMENSIONS (INCH)									WEIGHT (LBS)
				ØD1	ØD2	B	O	TA	TL	L	T	ØZ	
SRB 355.xx.5.55.E	60	5/16 - 7/8	12	16.1	14	33	4.4	19.7	44.6	51.4	TBD	TBD	1100
SRB 360.xx.5.64.E	70	5/8 - 7/8	16	16.1	14.2	39.1	4.4	19.7	47.2	54.1	TBD	TBD	1320
SRB 528.xx.5.70.E	77	7/8 - 1 1/4	16	23.4	20.8	40.8	4.4	27.9	55.7	63.1	TBD	TBD	2800
SRB 400.xx.5.73.E	80	5/8 - 1	16	18.1	15.7	37.6	4.4	22.4	49.6	56.7	TBD	TBD	1650
SRB 360.xx.5.80.E	88	5/8 - 7/8	20	16.1	14.2	39.1	4.9	19.7	50.5	58.1	TBD	TBD	1805
SRB 400.xx.5.82.E	90	5/8 - 1	20	18.1	15.7	40.7	4.9	22.4	53.7	61.6	TBD	TBD	1800
SRB 450.xx.5.82.E	90	3/4 - 1 1/8	20	20.3	17.7	42.2	4.9	23.6	56.3	64.2	TBD	TBD	2250
SRB 450.xx.5.100.E	110	3/4 - 1 1/8	25	20.3	17.7	44.4	5.5	23.6	58.5	67.6	TBD	TBD	2500
SRB 528.xx.5.125.E	137.5	7/8 - 1 1/4	32	23.4	20.8	49.7	6.3	28	66.8	76.6	TBD	TBD	3500
SRB 528.xx.5.137,5.E	150	7/8 - 1 1/4	32	23.4	20.8	52.5	6.3	28	50.1	77.8	TBD	TBD	3500
SRB 528.xx.5.160.E	176	7/8 - 1 1/4	40	23.4	20.8	55.4	7.1	28	70.7	81.8	TBD	TBD	3640
FRB 670.xx.5.200.E	220	1 - 1 3/8	50	29.9	26.4	64.6	7.9	34.3	83.9	95.9	TBD	TBD	7830

NOTE xx = To be replaced by metric wire size in final part number n TBD = These dimensions vary with wire size

- The dimensions in this table are indicative only. A drawing will always be submitted prior to production and will be the leading document when discussing dimensions.
- Blocks shown here are standard models; inquiries for custom versions are welcome.
- Refer to wire rope manufacturers D/d ratio guideline.
- Hook locking pin included on all blocks 40M ton and higher

Minimum Ultimate Strength = 4 x WLL.

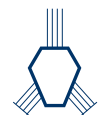

ROPEBLOCK

OVERHAUL BALLS

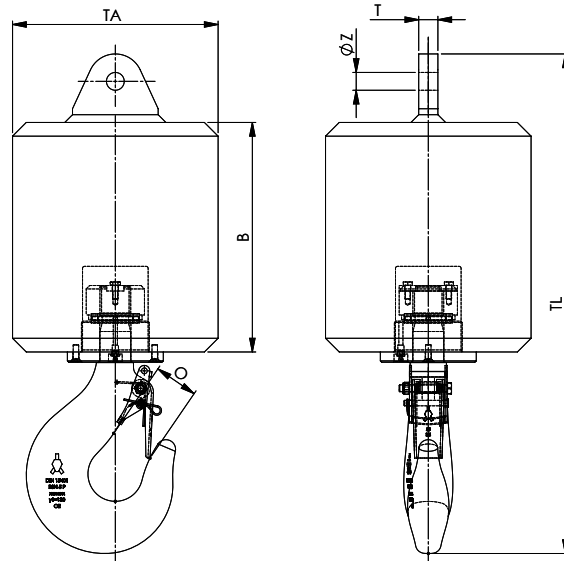

MODEL NO.	WLL (UST)	FOR WIRE ØD INCH	HOOK SIZE	BECKET	DIMENSIONS (INCH)						WEIGHT (LBS)
					B	O	TA	TL	T	ØZ	
OHB 3,2.60.C-1	3.5	½	2.5	1	7.9	2.0	8.7	19.7	0.9	1.1	130
OHB 3,2.60.C-2	3.5	⅞ - ⅝	2.5	2	7.9	2.0	8.7	19.9	1.1	1.3	130
OHB 5.80.C-2	5.5	⅞ - ⅝	2.5	2	8.7	2.0	9.4	22.3	1.1	1.3	175
OHB 6,3.80.C-2	6.9	⅞ - ⅝	2.5	2	8.7	2.0	9.4	22.3	1.1	1.3	175
OHB 8.130.C-3	8.8	¾	4	3	12.2	2.2	10.1	28.3	1.4	1.5	285
OHB 8.170.C-3	8.8	¾	4	3	13.4	2.2	10.9	26.8	1.4	1.5	375
OHB 8.200.C-3	8.8	¾	5	3	13.2	2.5	11.8	28.7	1.1	1.0	440
OHB 8.250.C-3	8.8	¾	4	3	15.7	2.2	12.5	34.0	1.4	1.5	550
OHB 10.210.C-4	11	⅞	4	4	15.0	2.2	11.7	29.6	1.6	1.7	460
OHB 10.250.C-5	11	1	4	5	15.7	2.2	12.5	30.4	1.8	2.0	550
OHB 12.300.C	13.2	⅞ - 1	8	O.R.	14.6	3.1	13.8	34.9	1.1	1.4	660
OHB 12.328.C-4	13.2	⅞	5	4	15.8	2.5	13.8	34.6	1.6	1.7	722
OHB 12.400.C	13.2	1⅜ - 1	8	O.R.	16.3	3.1	15.0	36.7	1.1	1.4	880
OHB 12,5.200.C-4	13.75	⅞	5	4	13.2	2.5	11.8	31.3	1.6	1.7	440
OHB 12,5.250.C-5	13.75	1	5	5	15.7	2.5	12.5	32.6	1.8	2.0	550
OHB 12,5.370.C-5	13.75	1	5	5	17.7	2.5	13.8	34.6	1.8	2.0	814
OHB 16.275.P-4	17.6	⅞	6	4	13.8	2.8	13.8	34.0	1.6	1.7	605
OHB 16.370.C-5	17.6	1	6	5	17.7	2.8	12.5	38.7	1.8	2.0	814
OHB 16.450.C-5	17.6	1	6	5	17.3	2.8	15.7	38.3	1.8	2.0	990
OHB 16.545.P-5	17.6	1	6	5	18.1	2.8	17.7	39.5	1.8	2.0	1200
OHB 20.575.P-6	22	1⅞	8	6	18.5	3.1	16.0	42.3	2.0	2.3	1265
OHB 20.600.P-6	22	1⅞	8	6	18.7	3.1	17.7	42.0	2.0	2.3	1320
OHB 20.725.P-6	22	1⅞	8	6	24.0	3.1	17.7	47.2	2.0	2.3	1600
OHB 20.910.P-6	22	1⅞	8	6	24.2	3.1	19.7	47.4	2.0	2.3	2000
OHB 25.725.P-7	27.5	1¼	8	7	20.1	3.1	18.1	42.4	2.4	2.6	1600
OHB 25.725.P-8	27.5	1⅜	8	8	20.1	3.1	18.1	42.4	2.4	2.6	1600
OHB 25.910.P-7	27.5	1¼	8	7	24.0	3.1	18.1	46.4	2.4	2.6	2000
OHB 25.910.P-8	27.5	1⅜	8	8	24.0	3.1	18.1	46.4	2.4	2.6	2000
OHB 32.365.P-8	35	1⅞	10	6	15.7	3.5	14.6	49.6	2.6	2.6	800
OHB 32.725.P-7	35	1¼	10	7	23.6	3.5	17.7	45.4	2.4	2.6	1600
OHB 32.910.P-9	35	1½	10	9	24.2	3.5	19.7	46.0	2.8	2.8	2000

- The dimensions in this table are indicative only. A drawing will always be submitted prior to production and will be the leading document when discussing dimensions.
- Products shown here are standard models; inquiries for custom versions are welcome.

Minimum Ultimate Strength = 4 x WLL.



ROPEBLOCK

ROUND OVERHAUL BALLS

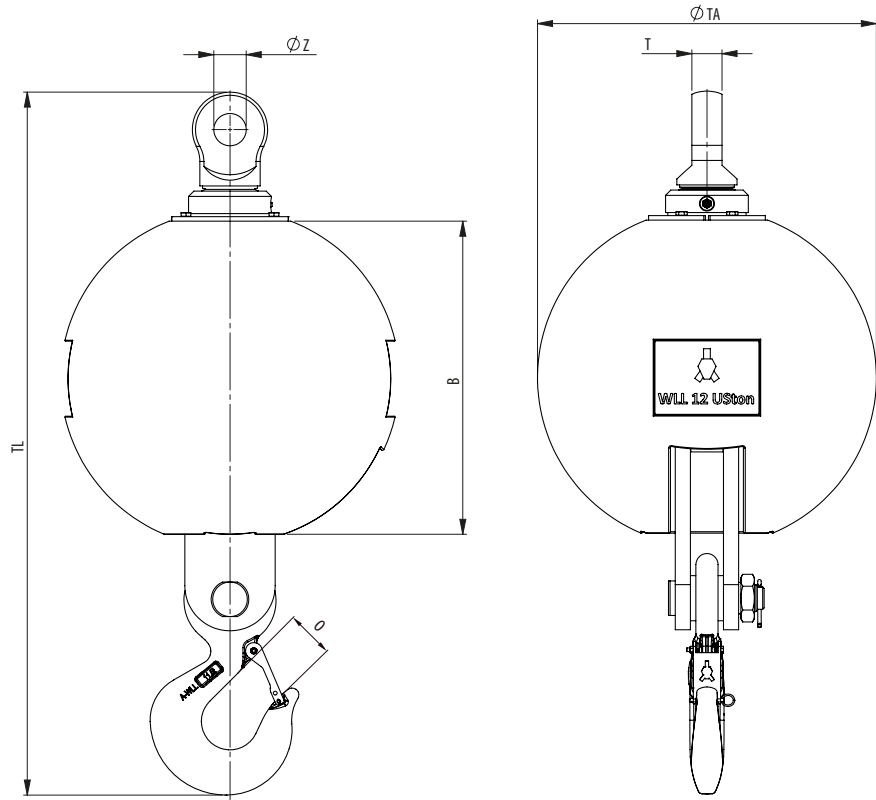

MODEL NO.	WLL (UST)	BECKET	DIMENSIONS (INCH)						WEIGHT (LBS)
			B	O	ØTA	TL	T	ØZ	
OHB-B 4,5.45-1	5	1	7 13/16	1 3/8	9 1/16	23 1/4	7/8	1 1/16	100
OHB-B 4,5.100-2	5	2	11 3/8	1 3/8	12 5/16	25 5/16	1 1/8	1 5/16	220
OHB-B 4,5.140-2	5	2	12 9/16	1 3/8	13 3/16	26 3/4	1 1/8	1 5/16	310
OHB-B 7.80-2	8	2	10	1 11/16	11	26 1/4	1 1/8	1 5/16	175
OHB-B 7.110-2	8	2	11 3/8	1 11/16	12 5/16	27 7/16	1 1/8	1 5/16	242
OHB-B 7.145-3	8	3	12 9/16	1 11/16	13 3/16	28 15/16	1 3/8	1 7/16	320
OHB-B 11.180-3	12	3	13 1/8	2 1/16	14 9/16	33 1/16	1 3/8	1 7/16	396
OHB-B 11.265-4	12	4	15 3/8	2 1/16	16 3/4	35 7/8	1 9/16	1 11/16	583
OHB-B 11.320-4	12	4	16 7/16	2 1/16	17 11/16	36 7/8	1 9/16	1 11/16	705
OHB-B 11.530-4	12	4	20	2 1/16	21 1/16	40 7/16	1 9/16	1 11/16	1165
OHB-B 18.195-5	20	5	13 1/8	3 1/16	14 9/16	38 5/16	1 3/4	2 1/16	429
OHB-B 18.330-6	20	6	16 7/16	3 1/16	17 11/16	42	1 15/16	2 5/16	726
OHB-B 18.545-6	20	6	20	3 1/16	21 1/16	45 9/16	1 15/16	2 5/16	1200

- The dimensions in this table are indicative only. A drawing will always be submitted prior to production and will be the leading document when discussing dimensions.
- Productss shown here are standard models; inquiries for custom versions are welcome.

Minimum Ultimate Strength = 4 x WLL.

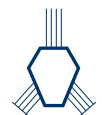

ROPEBLOCK

SPLIT OVERHAUL BALLS

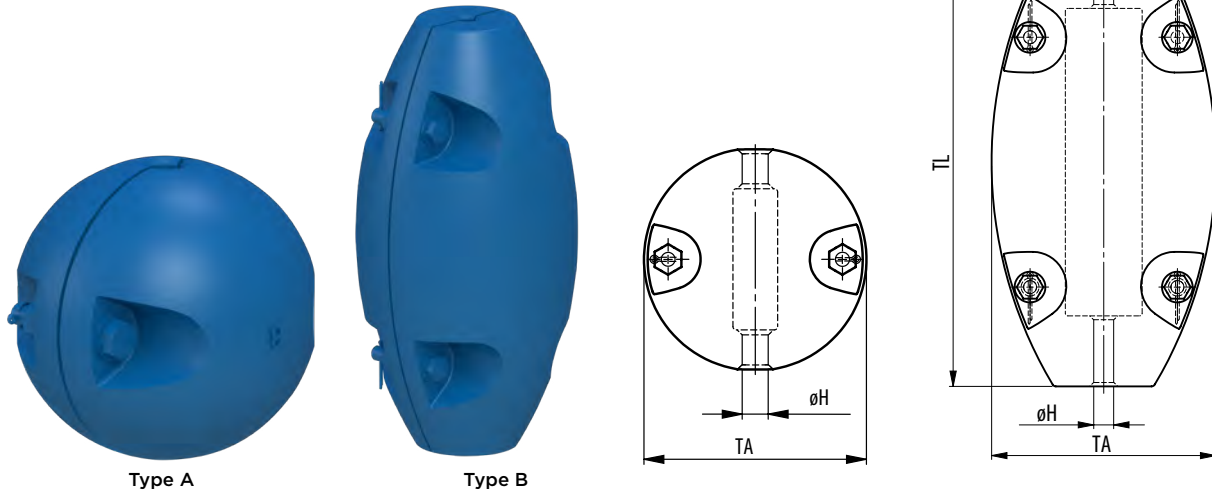

MODEL NO.	TYPE	WIRE ϕ (INCH)	DIMENSIONS (INCH)			WEIGHT (LBS)
			ϕH	TA	TL	
SOBA 5.6	A	1/4	0.24	4.33	-	11.0
SOBA 5.12	A	1/2	0.47	4.33	-	11.0
SOBA 8.16	A	5/8	0.63	5.28	-	17.6
SOBA 10.12	A	1/2	0.47	5.91	-	22.0
SOBA 15.16	B	5/8	0.63	5.31	8.27	33.1
SOBA 25.16	B	5/8	0.63	5.91	10.24	55.1
SOBA 35.16	B	5/8	0.63	6.69	13.78	77.2
SOBA 50.20	B	1 3/16	0.79	7.87	14.17	110.2
SOBA 75.20	B	1 3/16	0.79	10.63	14.57	165.3
SOBA 100.28	B	1 1/8	1.10	11.02	15.75	220.5

- Weights can be made suitable for larger wire diameters (optional).
- Painted blue (RAL 5017).

Minimum Ultimate Strength = 4 x WLL.

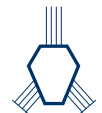

ROPEBLOCK

SNATCH BLOCKS

SAFETY ANCHOR
SHACKLE INCLUDED

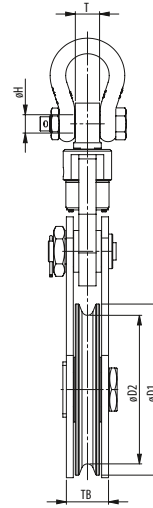
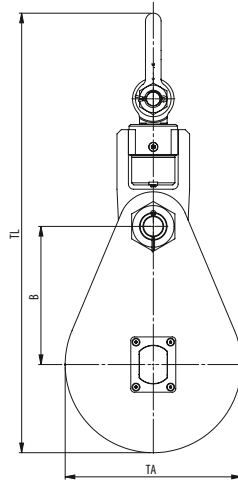

- HOOK
- CLEVIS
- TAILBORD
- OBLONG EYE

MODEL NO.	WLL (UST)	FOR WIRE ØD INCH	DIMENSIONS (INCH)								WEIGHT (LBS)
			ØD1	ØD2	B	ØH	T	TA	TB	TC (TL)	
VB 355.22.1.14.S	15	7/8	16.1	14	13	1.4	1.9	16.6	3.6	35	190
VB 240.28.1.20.S	22	1 - 1/8	11.8	9.4	10	1.5	1.9	12.2	3.3	28.9	120
VB 300.32.1.20.S	22	1 1/8 - 1 1/4	14.4	11.8	11.3	1.5	1.9	14.8	3.3	31.4	130
VB 240.28.1.25.S	27.5	1 - 1/8	11.8	9.4	10	1.6	2.1	12.2	3.3	28.6	125
VB 300.32.1.25.S	27.5	1 1/8 - 1 1/4	14.4	11.8	11.3	1.6	2.1	14.8	3.3	31.2	140
VB 390.26.1.25.S	27.5	7/8 - 1	17.7	15.4	13.8	2.1	2.8	16.1	4.4	39.5	265
VB 240.28.1.27.S	30	1 - 1/8	11.8	9.4	10	1.7	2.2	12.2	3.3	32	150
VB 300.32.1.27.S	30	1 1/8 - 1 1/4	14.4	11.8	11.3	1.7	2.2	14.8	3.3	34.6	185
VB 345.32.1.32.S	35	1 1/8 - 1 1/4	15.7	13.6	12.8	2.1	2.8	16.1	4.4	37.4	265
VB 345.36.1.32.S	35	1 1/4 - 1 3/8	15.7	13.6	12.8	2.1	2.8	16.1	4.4	37.4	265
VB 390.32.1.32.S	35	1 1/8 - 1 1/4	17.7	15.4	13.8	2.1	2.8	18.5	4.4	39.5	310
VB 390.38.1.32.S	35	1 3/8 - 1 1/2	17.7	15.4	13.8	2.1	2.8	18.5	4.4	39.5	310
VB 430.32.1.32.S	35	1 1/8 - 1 1/4	19.5	16.9	14.8	2.1	2.8	20.1	4.4	41.3	330
VB 430.38.1.32.S	35	1 3/8 - 1 1/2	19.5	16.9	14.8	2.1	2.8	20.1	4.4	41.3	330
VB 520.32.1.32.S	35	1 1/8 - 1 1/4	23.4	20.5	17.1	2.1	2.8	24	4.4	45.6	660
VB 430.32.1.36.5.S	40	1 1/8 - 1 1/4	19.5	16.9	15.7	2.1	2.8	20.1	4.8	42.7	440
VB 430.38.1.36.5.S	40	1 3/8 - 1 1/2	19.5	16.9	15.7	2.1	2.8	20.1	4.8	42.7	440
VB 430.38.1.46.S	50	1 - 3/8 - 1 - 1/2	19.5	16.9	15.8	2.1	2.8	20.1	4.8	43.2	440
VB 520.38.1.46.S	50	1 - 3/8 - 1 - 1/2	23.4	20.5	18.1	2.1	2.8	24	4.8	47.5	550
VB 520.44.1.46.S	50	1 - 1/2 - 1 - 3/4	23.4	20.5	18.1	2.1	2.8	24	4.8	47.5	550
VB 240.28.1.55.S	60	1 - 1 - 1/8	11.8	9.4	11.4	2.3	3.1	12.2	5.6	37.8	383
VB 520.38.1.55.S	60	1 - 3/8 - 1 - 1/2	23.4	20.5	18.1	2.3	3.1	24	5.6	50.4	680
VB 520.44.1.55.S	60	1 - 1/2 - 1 - 3/4	23.4	20.5	18.1	2.3	3.1	24	5.6	50.4	680
VB 520.52.1.55.S	60	1 - 3/4 - 2	23.4	20.5	18.1	2.3	3.1	24	5.6	50.4	680
VB 520.52.1.75.S	82,5	1 - 3/4 - 2	23.4	20.5	18.1	2.9	3.9	24	5.6	52.6	726
VB 630.58.1.75.S	82,5	1 - 3/4 - 2 - 1/4	29.5	24.8	22.4	2.9	3.9	30.3	8	71.5	1265
VB 710.68.1.100.S	110	2 - 1/2 - 2 - 5/8	31.5	28	25.6	3.4	4.7	32.3	8	75.2	1605
VB 800.76.1.125.S	137,5	2 - 3/4 - 3	35	31.5	29.5	3.4	4.7	36.2	8	84.6	2200

Minimum Ultimate Strength = 4 x WLL.

- The dimensions in this table are indicative only. A drawing will always be submitted prior to production and will be the leading document when discussing dimensions.
- Blocks shown here are standard models; inquiries for custom versions are welcome.
- Refer to wire rope manufacturers D/d ratio guideline.
- Standard provided with bronze bushing. Roller bearing option available on some models.



ROPEBLOCK

SNATCH BLOCKS

SAFETY ANCHOR SHACKLE INCLUDED

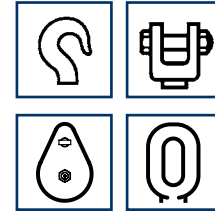
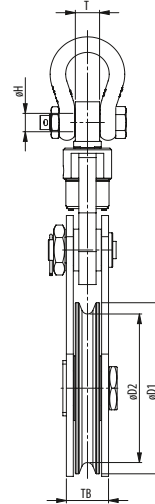
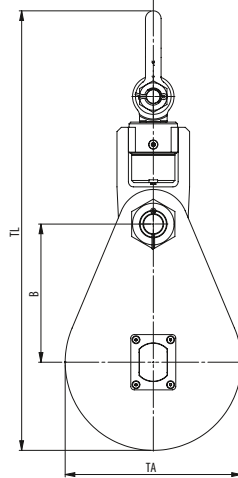

- HOOK
- CLEVIS
- TAILBORD
- OBLONG EYE

MODEL NO.	WLL (UST)	FOR WIRE ØD INCH	DIMENSIONS (INCH)								WEIGHT (LBS)
			ØD1	ØD2	B	ØH	T	TA	TB	TC (TL)	
VB 430.38.1.46.S	50	1 $\frac{3}{8}$ - 1 $\frac{1}{2}$	19.5	16.9	15.8	2.1	2.8	20.1	4.8	43.2	440
VB 520.38.1.46.S	50	1 $\frac{3}{8}$ - 1 $\frac{1}{2}$	23.4	20.5	18.1	2.1	2.8	24	4.8	47.5	550
VB 520.44.1.46.S	50	1 $\frac{1}{2}$ - 1 $\frac{3}{4}$	23.4	20.5	18.1	2.1	2.8	24	4.8	47.5	550
VB 240.28.1.55.S	60	1 - 1 $\frac{1}{8}$	11.8	9.4	11.4	2.3	3.1	12.2	5.6	37.8	383
VB 520.38.1.55.S	60	1 $\frac{3}{8}$ - 1 $\frac{1}{2}$	23.4	20.5	18.1	2.3	3.1	24	5.6	50.4	680
VB 520.44.1.55.S	60	1 $\frac{1}{2}$ - 1 $\frac{3}{4}$	23.4	20.5	18.1	2.3	3.1	24	5.6	50.4	680
VB 520.52.1.55.S	60	1 $\frac{3}{4}$ - 2	23.4	20.5	18.1	2.3	3.1	24	5.6	50.4	680
VB 520.52.1.75.S	82.5	1 $\frac{3}{4}$ - 2	23.4	20.5	18.1	2.9	3.9	24	5.6	52.6	726
VB 630.58.1.75.S	82.5	1 $\frac{3}{4}$ - 2 $\frac{1}{4}$	29.5	24.8	22.4	2.9	3.9	30.3	8	71.5	1265
VB 710.68.1.100.S	110	2 $\frac{1}{2}$ - 2 $\frac{5}{8}$	31.5	28	25.6	3.4	4.7	32.3	8	75.2	1605
VB 800.76.1.125.S	137.5	2 $\frac{3}{4}$ - 3	35	31.5	29.5	3.4	4.7	36.2	8	84.6	2200

Minimum Ultimate Strength = 4 x WLL.

Also Available in Double Sheave Models:

VB 240.28.2.20.S*	22	1 - 1 $\frac{1}{8}$	11.8	9.4	10	1.5	1.9	12.2	6.2	26.9	200
VB 300.32.2.32.S	35	1 $\frac{1}{8}$ - 1 $\frac{1}{4}$	14.4	11.8	11.3	2.1	2.8	14.8	6.2	32.8	265
VB 345.32.2.36.5.S	40	1 $\frac{1}{8}$ - 1 $\frac{1}{4}$	15.7	13.6	12.8	2.1	2.8	16.1	8.2	48.6	500
VB 430.32.2.55.S	60	1 $\frac{3}{8}$ - 1 $\frac{1}{2}$	19.5	16.9	15.8	2.3	3.1	20.1	9.4	62	770
VB 430.28.2.73.S	80	1 $\frac{1}{8}$ - 1 $\frac{1}{2}$	19.5	16.9	16.1	2.8	3.9	20.1	9.6	61	880
VB 520.38.2.125.S	137.5	1 $\frac{3}{8}$ - 1 $\frac{1}{2}$	23.4	20.5	18.1	3.4	4.7	24	10.1	57.1	1345

Minimum Ultimate Strength = 4 x WLL.

* Available with and without Dead End

- The dimensions in this table are indicative only. A drawing will always be submitted prior to production and will be the leading document when discussing dimensions.
- Blocks shown here are standard models; inquiries for custom versions are welcome.
- Refer to wire rope manufacturers D/d ratio guideline.
- Standard provided with bronze bushing. Roller bearing option available on some models.

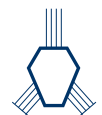

ROPEBLOCK

HIGH CAPACITY LIGHT WEIGHT BLOCKS

LIGHT WEIGHT TILT-UP BLOCKS

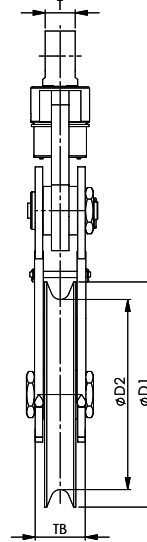
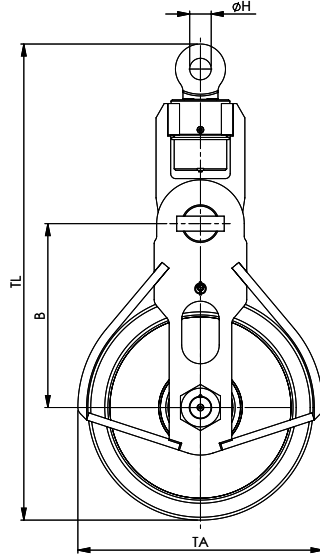

- HOOK
- CLEVIS
- TAILBORD
- OBLONG EYE

MODEL NO.	WLL (UST)	FOR WIRE ØD INCH	DIMENSIONS (INCH)								WEIGHT (LBS)
			ØD1	ØD2	B	ØH	T	TA	TB	TL	
HCLW 240.28.1.25.S	27.5	1 - 1 ½	11.8	9.4	10.2	1.6	2.1	14.0	4.0	28.7	155
HCLW 355.32.1.27.S	30	1 ½ - 1 ¾	16.5	14.0	14.8	1.7	2.2	18.7	4.4	39.1	265
HCLW 355.36.1.32.S	35	1 ¼ - 1 ¾	16.5	14.0	14.8	1.7	2.2	18.7	4.8	39.1	265
HCLW 430.32.1.27.S	30	1 ½ - 1 ¾	19.5	16.9	16.3	1.7	2.2	21.7	4.4	42.2	240
HCLW 430.32.1.32.S	35	1 ½ - 1 ¾	19.5	16.9	16.3	1.7	2.2	21.7	4.8	42.1	285
HCLW 430.38.1.32.S	35	1 ¼ - 1 ½	19.5	16.9	16.3	1.7	2.2	21.7	4.8	42.1	255
HCLW 430.38.1.40.S	45	1 ¼ - 1 ½	19.5	16.9	16.3	2.0	2.8	21.7	4.8	43.6	320
HCLW 520.38.1.55.S	60	1 ¼ - 1 ½	23.4	20.5	19.1	2.8	3.9	25.6	5.2	51.9	420
HCLW 520.44.1.55.S	60	1 ¼ - 1 ¾	23.4	20.5	19.1	2.3	3.1	25.6	5.2	51.5	420
HCLW 520.52.1.55.S	60	1 ¾ - 2	23.4	20.5	19.1	2.3	3.1	25.6	5.2	51.5	420
HCLW 630.58.1.81.S	90	2 - 2 ¼	28.0	24.8	22.6	2.9	3.9	30.6	6.0	62.4	880
HCLW 630.64.1.81.S	90	2 ¼ - 2 ½	28.0	24.8	22.6	2.9	3.9	30.6	6.0	62.4	880
HCLW 760.70.1.100.S	110	2 ½ - 2 ¾	35.4	29.9	28.9	3.4	4.7	38.6	7.9	74.9	1200
HCLW 760.76.1.100.S	110	2 ¾ - 3	35.4	29.9	28.9	3.4	4.7	38.6	7.9	74.9	1200
HCLW 760.76.1.125.S	137.5	2 ¾ - 3	35.4	29.9	28.9	3.3	4.7	38.6	7.9	74.4	1320
HCLW 760.76.1.137.5.S	150	2 ¾ - 3	35.4	29.9	28.9	3.3	4.7	38.6	7.9	74.4	1540

Minimum Ultimate Strength = 4 x WLL.

- The dimensions in this table are indicative only. A drawing will always be submitted prior to production and will be the leading document when discussing dimensions.
- Blocks shown here are standard models; inquiries for custom versions are welcome.
- Refer to wire rope manufacturers D/d ratio guideline.



ROPEBLOCK

HIGH CAPACITY LIGHT WEIGHT BLOCKS

LIGHT WEIGHT TILT-UP BLOCKS

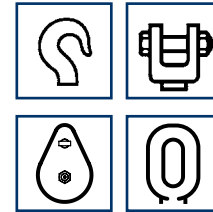
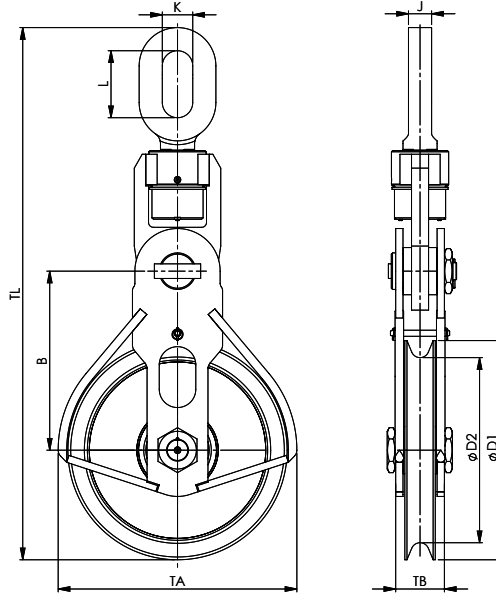

- HOOK
- CLEVIS
- TAILBORD
- OBLONG EYE

MODEL NO.	WLL (UST)	FOR WIRE ØD INCH	DIMENSIONS (INCH)									WEIGHT (LBS)
			ØD1	ØD2	B	J	K	L	TA	TB	TL	
HCLW 240.28.1.25.O	27.5	1 - 1 ½	11.8	9.4	10.2	2.0	3.0	5.9	14.0	4.0	37.2	175
HCLW 355.32.1.27.O	30	1 ½ - 1 ¾	16.5	14.0	14.8	2.4	3.1	6.9	18.7	4.4	47.0	290
HCLW 355.36.1.32.O	35	1 ¾ - 1 ¾	16.5	14.0	14.8	2.4	3.1	6.9	18.7	4.8	47.0	290
HCLW 430.32.1.27.O	30	1 ½ - 1 ¾	19.5	16.9	16.3	2.4	3.1	6.9	21.7	4.4	50.0	275
HCLW 430.32.1.32.O	35	1 ½ - 1 ¾	19.5	16.9	16.3	2.4	3.1	6.9	21.7	4.4	49.0	310
HCLW 430.38.1.32.O	35	1 ¾ - 1 ½	19.5	16.9	16.3	2.4	3.1	6.9	21.7	4.8	50.0	290
HCLW 430.38.1.40.O	45	1 ¾ - 1 ½	19.5	16.9	16.3	2.6	3.5	7.9	21.7	4.8	51.6	340
HCLW 520.38.1.55.O	60	1 ¾ - 1 ½	23.4	16.9	19.1	2.6	3.5	7.5	25.6	5.2	60.0	480
HCLW 520.44.1.55.O	60	1 ½ - 1 ¾	23.4	20.5	19.1	2.8	3.9	8.7	25.6	5.2	60.5	480
HCLW 520.52.1.55.O	60	1 ¾ - 2	23.4	20.5	19.1	2.8	3.9	8.7	25.6	5.2	60.5	480
HCLW 630.58.1.81.O	90	2 - 2 ¼	28.0	24.8	22.6	3.1	4.3	9.8	30.6	6.0	74.1	915
HCLW 630.64.1.81.O	90	2 ¼ - 2 ½	28.0	24.8	22.6	3.1	4.3	9.8	30.6	6.0	74.1	915
HCLW 760.70.1.100.O	110	2 ½ - 2 ¾	35.4	29.9	28.9	3.7	4.9	10.8	38.6	7.9	86.2	1300
HCLW 760.76.1.100.O	110	2 ¾ - 3	35.4	29.9	28.9	3.7	4.9	10.8	38.6	7.9	86.2	1300
HCLW 760.76.1.125.O	137.5	2 ¾ - 3	35.4	29.9	28.9	3.9	4.9	10.8	38.6	7.9	86.2	1430
HCLW 760.76.1.137.5.O	150	2 ¾ - 3	35.4	29.9	28.9	3.9	4.9	10.8	38.6	7.9	86.2	1650

Minimum Ultimate Strength = 4 x WLL.

- The dimensions in this table are indicative only. A drawing will always be submitted prior to production and will be the leading document when discussing dimensions.
- Blocks shown here are standard models; inquiries for custom versions are welcome.
- Refer to wire rope manufacturers D/d ratio guideline.

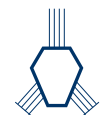

ROPEBLOCK

SINGLE SHEAVE COMPACT CRANE BLOCKS

SINGLE ACTION HOOK

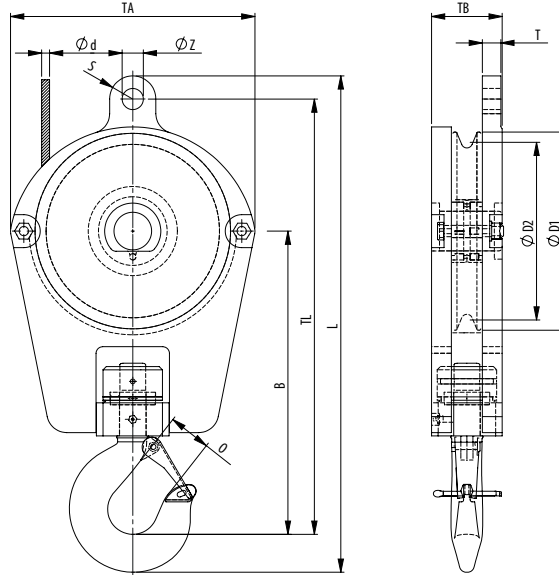

MODEL NO.	MODEL NO.	WLL (UST)	FOR WIRE ØD INCH	DIMENSIONS (INCH)											WEIGHT (LBS)
				ØD1	ØD2	B	O	R	S	TA	TB	TL	T	ØZ	
HB 210.11.1.5.E	21.250.05.11-11	5.5	7/16	9 13/16	8 1/4	13 11/16	1 5/16	1/4	1 3/16	12 5/8	4 1/16	20 9/16	13/16	11/16	90
HB 220.13.1.5.E	21.260.05.11-13	5.5	1/2	10 1/4	8 11/16	13 7/8	1 5/16	1/4	1 3/16	13 7/8	4 5/16	20 11/16	7/8	11/16	148
HB 220.14.1.8.E	21.260.08.11-14	8.8	9/16	10 1/4	8 9/16	15 3/8	1 11/16	5/16	1 3/8	13	4 3/4	22 1/2	11/8	1 1/4	176
HB 220.14.1.10.E	21.260.10.11-14	11	9/16	10 1/4	8 9/16	16 7/8	2 1/16	5/16	1 3/8	13	5 3/8	24	11/8	1 1/4	205
HB 255.13.1.8.E	21.300.08.11-13	8.8	1/2	11 13/16	10 1/16	16 3/4	1 11/16	1/4	1 3/16	14 9/16	4	24 7/16	7/8	11/16	196
HB 255.16.1.8.E	21.300.08.11-16	8.8	5/8	11 13/16	9 15/16	16 9/16	1 11/16	5/16	1 3/8	14 9/16	4 3/8	24 7/16	11/8	1 1/4	207
HB 255.16.1.10.E	21.300.10.11-16	11	5/8	11 13/16	9 15/16	18 1/16	2 1/16	5/16	1 3/8	14 9/16	5	25 15/16	11/8	1 1/4	201
HB 305.16.1.10.E	21.350.10.11-16	11	5/8	13 3/4	12	19 5/8	2 1/16	5/16	1 3/8	17 1/8	4 3/16	29 1/8	11/8	1 5/16	249
HB 345.18.1.12.E	21.400.12.11-18	13.2	11/16	15 3/4	13 9/16	21 15/16	2 1/4	3/8	1 3/4	19 11/16	4 15/16	32 3/4	1 3/8	1 7/16	357
HB 390.20.1.16.E	21.450.16.11-20	17.6	13/16	17 11/16	15 3/8	23 5/16	2 1/4	7/16	1 15/16	21 5/8	5 3/16	36 1/8	1 3/8	1 11/16	454
HB 430.22.1.20.E	21.500.20.11-22	22	7/8	19 11/16	16 15/16	23 5/16	3	1/2	1 15/16	23 5/8	5 13/16	40 5/8	1 9/16	1 11/16	626

Minimum Ultimate Strength = 4 x WLL.

- Standard fitted with becket, cylindrical roller bearing and reeving guide.
- Standard fitted with Crosby type of swivel only hook (319AN style), including safety latch and split pin. Standard painted yellow (no striping).
- This crane block may be used with 2 lines only as well.
- Third party testing with certification available upon request.
- Sheaves may be adjustud for other wire rope diameters.
- Becket suitable for connecting Open Wedge Socket for indicated wire rope.
- Becket cannot be adjusted.

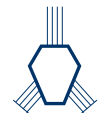

ROPEBLOCK

CONSTRUCTION BLOCK WITH SHACKLE

1 SHEAVE

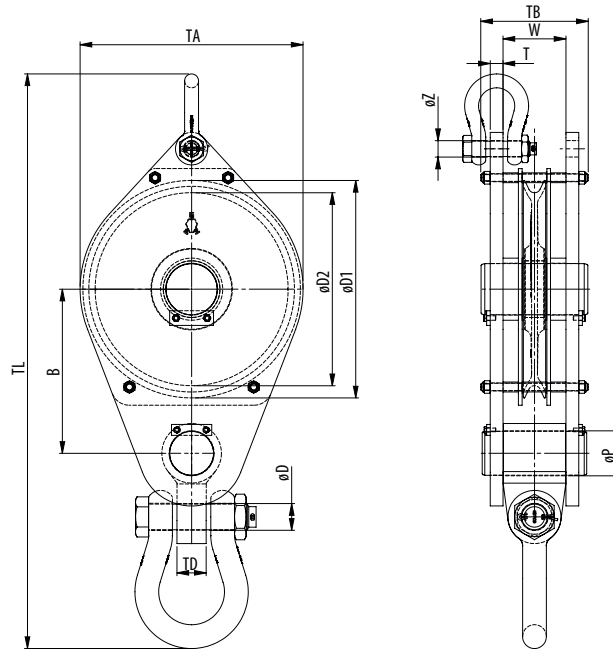

MODEL NO.	WLL (USTONS)	WLL (UST)	FOR WIRE ØD (INCH)	DIMENSIONS (INCH)											WEIGHT (LBS)
				ØD1	ØD2	B	ØD	ØP	TD	ØZ	TA	TB	TL	W	
CB 260.xx.1.18,5	20	1/2 - 5/8	11.8	10.2	10.1	1.8	2.4	1.4	1.1	0.8	12.2	7.5	35.3	4.2	165
CB 320.xx.1.27,5	30	5/8 - 3/4	14.4	12.6	11.7	2.1	2.8	1.8	1.2	1.0	14.8	8.4	41.2	4.7	279
CB 355.xx.1.36,5	40	3/4 - 7/8	16.1	14.0	13.4	2.4	3.9	2.4	1.6	1.2	16.5	9.9	48.3	5.8	452
CB 400.xx.1.45	50	3/4 - 1	18.1	15.7	14.5	2.7	3.9	2.6	1.6	1.2	18.5	10.2	52.5	5.8	568
CB 450.xx.1.55	60	7/8 - 1 1/8	20.3	17.7	16.1	2.9	4.7	3.1	1.8	1.4	20.9	11.6	58.7	6.8	835
CB 528.xx.1.64	70	7/8 - 1 1/4	23.4	20.8	17.7	2.9	4.7	3.1	1.8	1.4	24.0	11.6	61.9	6.8	1009
CB 575.xx.1.73	80	1 - 1 1/16	25.6	22.6	19.4	3.4	5.5	4.3	2.1	1.6	26.4	13.3	71.2	7.8	1436
CB 630.xx.1.82	90	1 - 1 1/2	28.0	24.8	20.6	3.4	5.5	4.3	2.1	1.6	28.7	13.3	73.6	7.8	1563

Minimum Ultimate Strength = 4 x WLL

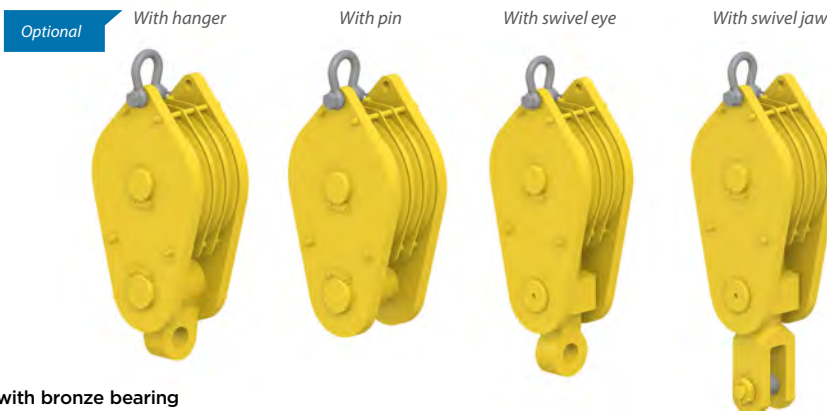

- Standard delivered with bronze bearing
- The dimensions in this table are indicative only. A drawing will always be submitted prior to production and will be the leading document when discussing dimensions.
- Blocks shown here are standard models; inquiries for custom versions are welcome.
- Refer to wire rope manufacturers D/d ratio guideline.

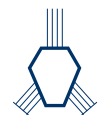

ROPEBLOCK

CONSTRUCTION BLOCK WITH SHACKLE

2 SHEAVE

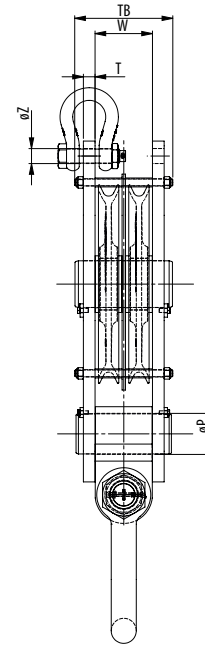
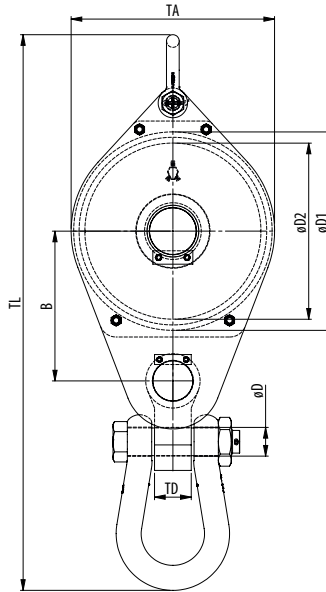

MODEL NO.	WLL (USTONS)	FOR WIRE ØD (INCH)	DIMENSIONS (INCH)											WEIGHT (LBS)	
			ØD1	ØD2	B	ØD	ØP	TD	ØZ	T	TA	TB	TL		W
CB 260.xx.2.27,5	30	½ - ⅝	11.8	10.2	10.1	2.1	2.4	1.8	1.1	0.8	12.2	7.5	37.3	4.2	194
CB 320.xx.2.41	45	⅝ - ¾	14.4	12.6	11.7	2.4	2.8	2.4	1.2	1.0	14.8	8.4	42.4	4.7	315
CB 355.xx.2.55	60	¾ - ⅞	16.1	14.0	13.4	2.9	3.9	3.1	1.6	1.2	16.5	9.9	52.3	5.8	520
CB 400.xx.2.68	75	¾ - 1	18.1	15.7	14.5	2.9	3.9	3.1	1.6	1.2	18.5	10.2	54.7	5.8	628
CB 450.xx.2.82	90	⅞ - 1⅛	20.3	17.7	16.1	3.4	4.7	4.3	1.8	1.4	20.9	11.6	62.4	6.8	940
CB 528.xx.2.100	110	⅞ - 1¼	23.4	20.8	17.7	3.4	4.7	4.3	1.8	1.4	24.0	11.6	65.6	6.8	1130
CB 575.xx.2.114	126	1 - 1⅙	25.6	22.6	19.4	3.9	5.5	4.7	2.1	1.6	26.4	13.3	75.9	7.8	1645
CB 630.xx.2.127	140	1 - 1½	28.0	24.8	20.6	3.9	5.5	4.7	2.1	1.6	28.7	13.3	78.3	7.8	1739

Minimum Ultimate Strength = 4 x WLL

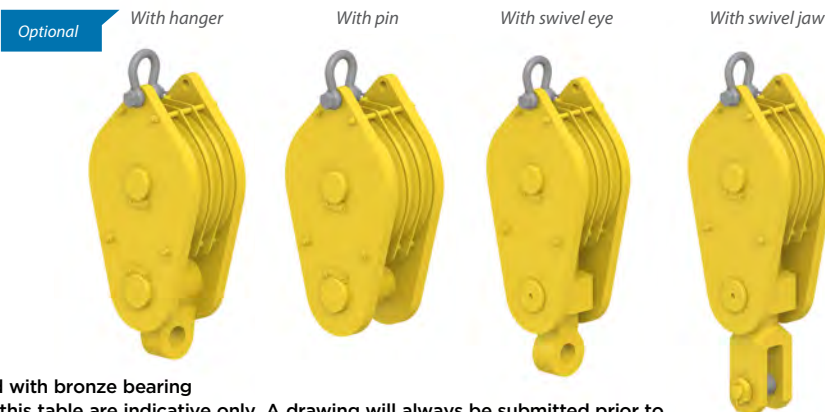

- Standard delivered with bronze bearing
- The dimensions in this table are indicative only. A drawing will always be submitted prior to production and will be the leading document when discussing dimensions.
- Blocks shown here are standard models; inquiries for custom versions are welcome.
- Refer to wire rope manufacturers D/d ratio guideline.



ROPEBLOCK

CONSTRUCTION BLOCK WITH SHACKLE

3 SHEAVE

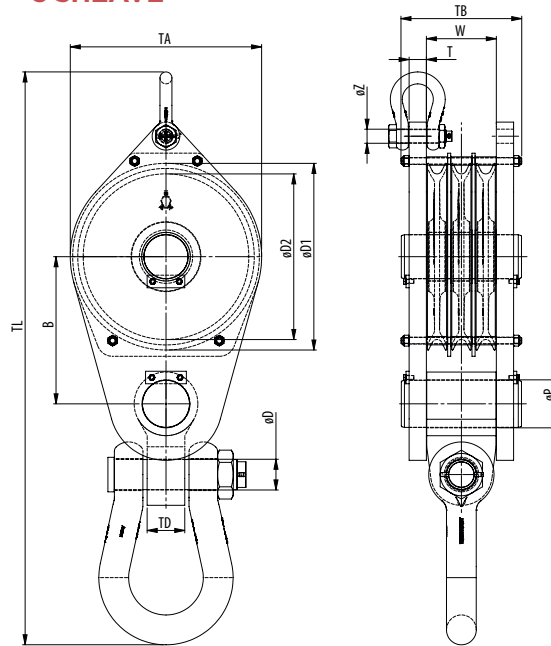

MODEL NO.	WLL (USTONS)	FOR WIRE ØD (INCH)	DIMENSIONS (INCH)											WEIGHT (LBS)	
			ØD1	ØD2	B	ØD	ØP	TD	ØZ	T	TA	TB	TL		W
CB 260.xx.3.36,5	40	½ - ⅝	11.8	10.2	10.7	2.4	3.1	2.4	1.1	1.2	12.2	9.9	39.6	5.8	298
CB 320.xx.3.55	60	⅝ - ¾	14.4	12.6	12.5	2.9	3.9	3.1	1.2	1.4	14.8	11.3	48.0	6.8	509
CB 355.xx.3.73	80	¾ - ⅞	16.1	14.0	14.1	3.4	5.1	4.3	1.6	1.8	16.5	13.1	57.6	7.8	825
CB 400.xx.3.91	100	¾ - 1	18.1	15.7	15.3	3.4	5.1	4.3	1.6	1.8	18.5	13.4	59.9	7.8	988
CB 450.xx.3.110	121	⅞ - 1⅛	20.3	17.7	16.9	3.9	5.9	4.7	1.8	2.2	20.9	15.2	68.7	8.8	1513
CB 528.xx.3.127	140	⅞ - 1¼	23.4	20.8	18.5	3.9	5.9	4.7	1.8	2.2	24.0	15.2	71.9	8.8	1813
CB 575.xx.3.145	160	1 - 1⅙	25.6	22.6	20.2	4.4	6.7	5.5	2.1	2.4	26.4	17.6	79.1	10.5	2510
CB 630.xx.3.165	182	1 - 1½	28.0	24.8	21.4	4.4	6.7	5.5	2.1	2.4	28.7	17.6	81.5	10.5	2656

Minimum Ultimate Strength = 4 x WLL

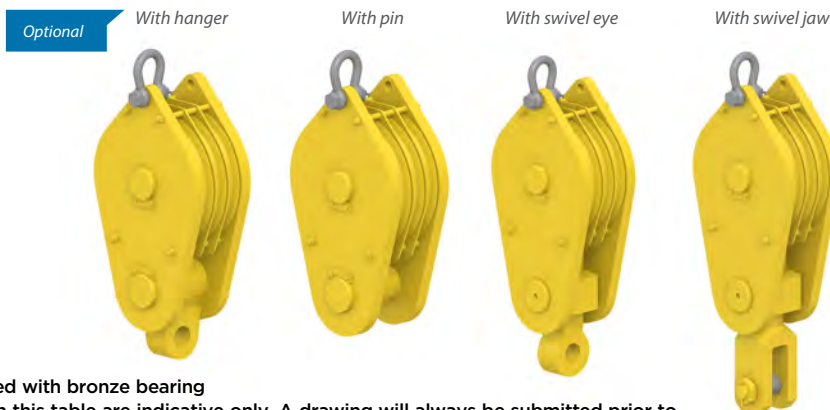

- Standard delivered with bronze bearing
- The dimensions in this table are indicative only. A drawing will always be submitted prior to production and will be the leading document when discussing dimensions.
- Blocks shown here are standard models; inquiries for custom versions are welcome.
- Refer to wire rope manufacturers D/d ratio guideline.



ROPEBLOCK

CONSTRUCTION BLOCK WITH SHACKLE

4 SHEAVE

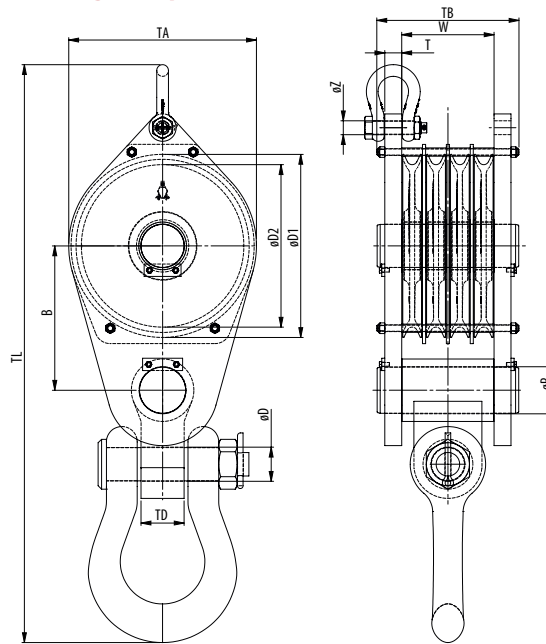

MODEL NO.	WLL (USTONS)	FOR WIRE ØD (INCH)	DIMENSIONS (INCH)												WEIGHT (LBS)
			ØD1	ØD2	B	ØD	ØP	TD	ØZ	T	TA	TB	TL	W	
CB 260.xx.4.41	45	½ - ⅝	11.8	10.2	10.7	2.4	3.1	2.4	1.1	1.2	12.2	11.9	39.6	7.8	334
CB 320.xx.4.64	70	⅝ - ¾	14.4	12.6	12.5	2.9	3.9	3.1	1.2	1.4	14.8	12.3	48.0	7.8	554
CB 355.xx.4.82	90	¾ - ⅞	16.1	14.0	14.1	3.4	5.1	4.3	1.6	1.8	16.5	15.7	57.6	10.5	918
CB 400.xx.4.105	116	¾ - 1	18.1	15.7	15.3	3.4	5.1	4.3	1.6	1.8	18.5	16.1	59.9	10.5	1109
CB 450.xx.4.127	140	⅞ - 1⅛	20.3	17.7	16.9	3.9	5.9	4.7	1.8	2.2	20.9	18.2	68.7	11.8	1690
CB 528.xx.4.150	165	⅞ - 1¼	23.4	20.8	18.5	4.4	5.9	5.5	1.8	2.2	24.0	18.2	73.5	11.8	2176
CB 575.xx.4.173	191	1 - 1⅙	25.6	22.6	20.2	4.4	6.7	5.5	2.1	2.4	26.4	21.0	79.1	13.9	2809
CB 630.xx.4.191	210	1 - 1½	28.0	24.8	21.4	5.2	6.7	5.5	2.1	2.4	28.7	21.0	87.4	13.9	3153

Minimum Ultimate Strength = 4 x WLL



- Standard delivered with bronze bearing
- The dimensions in this table are indicative only. A drawing will always be submitted prior to production and will be the leading document when discussing dimensions.
- Blocks shown here are standard models; inquiries for custom versions are welcome.
- Refer to wire rope manufacturers D/d ratio guideline.



ROPEBLOCK

SAMSON WIRE ROPE BLOCKS

1 SHEAVE

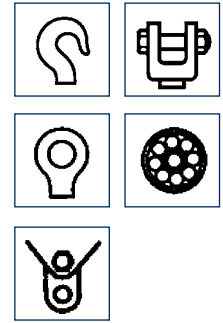
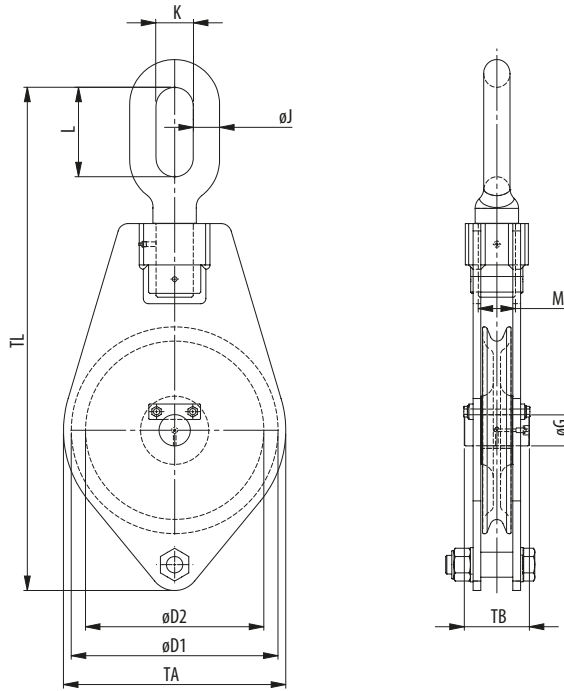

- Hook
- Jaw
- Stud eye
- Roller bearings
- Becket

MODEL NO. (+B FOR W BECKET)	WLL (USTONS)	FOR WIRE ØD (INCH)	DIMENSIONS (INCH)										WEIGHT (LBS)
			ØD1	ØD2	ØG	ØJ	K	L	M	TA	TB	TL	
WB 80.8.1.0.75.O	0.8	5/16	3.94	3.15	0.59	0.47	0.83	1.89	0.63	4.33	1.77	10.83	4
WB 105.10.1.1.O	1.1	3/8	4.92	4.13	0.87	0.63	1.02	2.28	0.71	5.31	2.05	13.23	7
WB 120.12.1.2.O	2.2	1/2	5.91	4.72	1.18	0.63	1.02	2.28	0.94	6.69	2.91	16.02	13
WB 165.14.1.3.O	3.3	9/16	7.87	6.50	1.18	0.83	1.26	2.83	1.18	8.66	2.91	19.69	22
WB 210.18.1.4.O	4.4	1 1/16	9.84	8.27	1.38	1.02	1.57	3.70	1.30	10.63	3.19	23.94	40
WB 255.20.1.6.O	6.6	1 3/16	11.81	10.04	1.57	1.14	1.77	4.25	1.65	12.60	3.46	27.80	60
WB 305.22.1.8.O	8.8	7/8	13.78	12.01	1.77	1.26	1.93	4.49	1.77	14.96	3.62	30.63	97
WB 305.22.1.10.O	11.0	7/8	13.78	12.01	1.97	1.42	2.13	4.92	2.05	14.96	4.33	31.30	110
WB 345.24.1.10.O	11.0	1 5/16	15.75	13.58	1.97	1.42	2.13	4.92	2.05	16.93	4.33	33.39	132
WB 305.22.1.12.O	13.2	7/8	13.78	12.01	1.97	1.61	2.36	5.67	2.20	14.96	4.49	32.32	130
WB 345.24.1.12.O	13.2	1 5/16	15.75	13.58	2.36	1.61	2.36	5.67	2.20	16.93	4.65	36.46	165
WB 305.22.1.16.O	17.6	7/8	13.78	12.01	1.97	1.81	2.60	6.42	2.52	14.96	4.49	34.61	152
WB 345.24.1.16.O	17.6	1 5/16	15.75	13.58	2.36	1.81	2.60	6.42	2.52	16.93	4.65	37.76	179
WB 345.24.1.20.O	22.0	1 5/16	15.75	13.58	2.36	2.01	2.83	6.81	2.83	16.93	4.65	38.98	214
WB 390.28.1.20.O	22.0	1 1/8	17.72	15.35	2.76	2.01	2.83	6.81	2.83	18.90	5.04	41.18	240
WB 390.28.1.25.O	27.6	1 1/8	17.72	15.35	2.76	2.36	3.15	7.68	2.99	18.90	5.04	43.50	287
WB 390.28.1.30.O	33.1	1 1/8	17.72	15.35	2.76	2.36	3.54	8.66	3.15	18.90	5.28	45.08	331

Minimum Ultimate Strength = 5 x WLL

WLL= Working Load Limit on head fitting.

- All blocks up to 30 tons are standard supplied with swivel oval eye, for over 30 tons with swivel stud eye.
- All blocks can be supplied with swivel hook, swivel stud eye or swivel jaw.
- Standard supplied with bronze bearings.
- Other bearings available on request.
- Groove in sheave may be adjusted to other wire rope diameters.

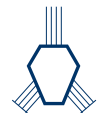

ROPEBLOCK

SAMSON WIRE ROPE BLOCKS

2 SHEAVE

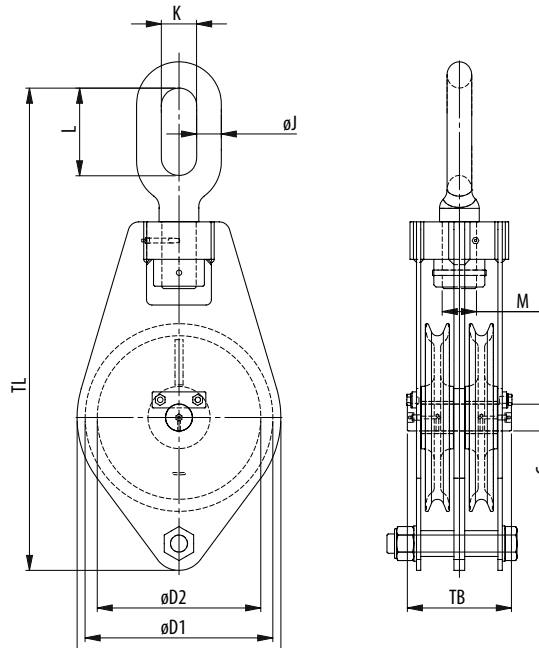

- Hook
- Jaw
- Stud eye
- Roller bearings
- Becket

MODEL NO. (+B FOR W BECKET)	WLL (USTONS)	FOR WIRE ØD (INCH)	DIMENSIONS (INCH)										WEIGHT (LBS)
			ØD1	ØD2	ØG	ØJ	K	L	M	TA	TB	TL	
WB 80.8.2.1.O	1.1	5/16	3.94	3.15	0.59	0.63	1.02	2.28	0.71	4.33	2.76	11.61	9
WB 105.10.2.1,5.O	1.7	3/8	4.92	4.13	0.87	0.63	1.02	2.28	0.94	5.31	3.35	13.23	13
WB 120.12.2.3.O	3.3	1/2	5.91	4.72	1.18	0.83	1.26	2.83	1.18	6.69	4.72	16.93	24
WB 165.14.2.4.O	4.4	9/16	7.87	6.50	1.18	1.02	1.57	3.70	1.30	8.66	4.72	21.18	40
WB 210.18.2.6.O	6.6	1 1/16	9.84	8.27	1.38	1.14	1.77	4.25	1.65	10.63	5.24	24.57	71
WB 255.20.2.8.O	8.8	1 3/16	11.81	10.04	1.57	1.26	1.93	4.49	1.77	12.60	5.75	28.07	95
WB 305.22.2.10.O	11.0	7/8	13.78	12.01	1.77	1.42	2.13	4.92	2.05	14.96	5.98	22.40	163
WB 305.22.2.12.O	13.2	7/8	13.78	12.01	1.97	1.61	2.36	5.67	2.20	14.96	7.32	32.32	179
WB 345.24.2.12.O	13.2	1 5/16	15.75	13.58	1.97	1.61	2.36	5.67	2.20	16.93	7.09	35.16	225
WB 305.22.2.16.O	17.6	7/8	13.78	12.01	1.97	1.81	2.60	6.42	2.52	14.96	7.32	34.61	216
WB 345.24.2.16.O	17.6	1 5/16	15.75	13.58	2.36	1.81	2.60	6.42	2.52	16.93	7.56	37.76	278
WB 305.22.2.20.O	22.0	7/8	13.78	12.01	1.97	2.01	2.83	6.81	2.83	14.96	7.32	35.28	256
WB 345.24.2.20.O	22.0	1 5/16	15.75	13.58	2.36	2.01	2.83	6.81	2.83	16.93	7.56	38.43	322
WB 345.24.2.25.O	27.6	1 5/16	15.75	13.58	2.36	2.36	3.15	7.68	2.99	16.93	7.56	41.93	373
WB 390.28.2.25.O	27.6	1 1/8	17.72	15.35	2.76	2.36	3.15	7.68	2.99	18.90	8.70	44.09	419
WB 345.24.2.30.O	33.1	1 5/16	15.75	13.58	2.36	2.36	3.54	8.66	3.15	16.93	7.56	43.11	406
WB 390.28.2.30.O	33.1	1 1/8	17.72	15.35	2.76	2.36	3.54	8.66	3.15	18.90	9.29	45.28	450
WB 390.28.2.40.O	44.1	1 1/8	17.72	15.35	2.76	-	3.78	3.78	3.54	18.90	9.29	40.55	496

Minimum Ultimate Strength = 5 x WLL

WLL= Working Load Limit on head fitting.

- All blocks up to 30 tons are standard supplied with swivel oval eye, for over 30 tons with swivel stud eye.
- All blocks can be supplied with swivel hook, swivel stud eye or swivel jaw.
- Standard supplied with bronze bearings.
- Other bearings available on request.
- Groove in sheave may be adjusted to other wire rope diameters.



ROPEBLOCK

SAMSON WIRE ROPE BLOCKS

3 SHEAVE

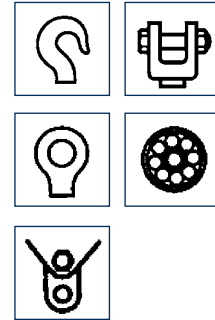
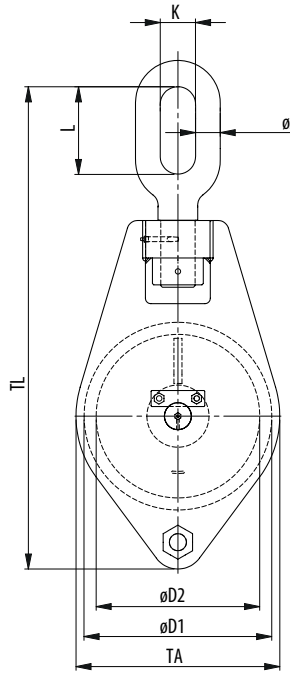

- Hook
- Jaw
- Stud eye
- Roller bearings
- Becket

MODEL NO. (+B FOR W BECKET)	WLL (USTONS)	FOR WIRE ØD (INCH)	DIMENSIONS (INCH)										WEIGHT (LBS)
			ØD1	ØD2	ØG	ØJ	K	L	M	TA	TB	TL	
WB 105.10.3.2.O	2.2	3/8	4.92	4.13	0.87	0.63	1.02	2.28	0.94	5.31	4.72	13.23	20
WB 120.12.3.4.O	4.4	1/2	5.91	4.72	1.18	1.02	1.57	3.70	1.30	6.69	6.54	18.43	37
WB 165.14.3.6.O	6.6	9/16	7.87	6.50	1.18	1.14	1.77	4.25	1.65	8.66	6.54	21.89	62
WB 210.18.3.8.O	8.8	1 1/16	9.84	8.27	1.38	1.26	1.93	4.49	1.77	10.63	7.28	24.92	101
WB 255.20.3.10.O	11.0	1 3/16	11.81	10.04	1.57	1.42	2.13	4.92	2.05	12.60	8.03	28.86	152
WB 305.22.3.12.O	13.2	7/8	13.78	12.01	1.77	1.61	2.36	5.67	2.20	14.96	8.35	32.40	218
WB 305.24.3.16.O	17.6	1 5/16	13.78	12.01	1.97	1.81	2.60	6.42	2.52	14.96	10.16	34.65	265
WB 345.24.3.16.O	17.6	1 5/16	15.75	13.58	1.97	1.81	2.60	6.42	2.52	16.93	9.84	36.50	346
WB 305.24.3.20.O	22.0	1 5/16	13.78	12.01	1.97	2.01	2.83	6.81	2.83	14.96	10.16	35.28	315
WB 345.24.3.20.O	22.0	1 5/16	15.75	13.58	2.36	2.01	2.83	6.81	2.83	16.93	10.47	39.61	406
WB 305.24.3.25.O	27.6	1 5/16	13.78	12.01	1.97	2.36	3.15	7.68	2.99	14.96	10.47	37.60	375
WB 345.24.3.25.O	27.6	1 5/16	15.75	13.58	2.36	2.36	3.15	7.68	2.99	16.93	10.47	41.93	437
WB 390.28.3.25.O	27.6	1 1/8	17.72	15.35	2.76	2.36	3.15	7.68	2.99	18.90	11.65	44.09	485
WB 345.28.3.30.O	33.1	1 1/8	15.75	13.58	2.36	2.36	3.54	8.66	3.15	16.93	10.47	43.11	474
WB 390.28.3.30.O	33.1	1 1/8	17.72	15.35	2.76	2.36	3.54	8.66	3.15	18.90	11.65	44.88	562
WB 345.28.3.40.O	44.1	1 1/8	15.75	13.58	2.36	-	3.78	3.78	3.54	16.93	10.94	37.20	551
WB 390.28.3.40.O	44.1	1 1/8	17.72	15.35	2.76	-	3.78	3.78	3.54	18.90	12.13	40.55	650
WB 390.28.3.50.O	55.1	1 1/8	17.72	15.35	2.95	-	4.17	4.17	3.94	18.90	13.31	41.54	739

Minimum Ultimate Strength = 5 x WLL

WLL= Working Load Limit on head fitting.

- All blocks up to 30 tons are standard supplied with swivel oval eye, for over 30 tons with swivel stud eye.
- All blocks can be supplied with swivel hook, swivel stud eye or swivel jaw.
- Standard supplied with bronze bearings.
- Other bearings available on request.
- Groove in sheave may be adjusted to other wire rope diameters.

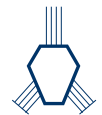

ROPEBLOCK

HORIZONTAL DIRECTIONAL BLOCKS

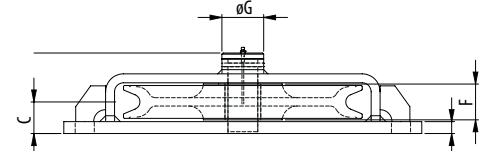
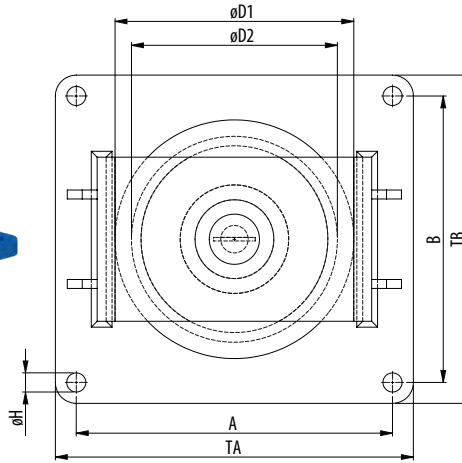

BRONZE BUSHING

MODEL NO.	WLL (USTONS)	WIRE SIZE (INCH)	BEARING	DIMENSIONS (INCH)											WEIGHT (LBS)	
				$\phi D1$	$\phi D2$	A	B	C	F	ϕG	ϕH	T	TA	TB		TC
HLS 105.10.1.1-BR	1.1	$\frac{3}{8}$	Bronze	4.92	4.13	7.09	5.91	0.89	1.06	0.87	0.35	0.31	7.87	6.69	2.13	5
HLS 120.12.1.2-BR	2.2	$\frac{1}{2}$	Bronze	5.91	4.72	8.66	7.48	1.22	1.57	1.18	0.43	0.39	9.84	8.66	2.83	10
HLS 165.14.1.3-BR	3.3	$\frac{9}{16}$	Bronze	7.87	6.50	11.42	9.45	1.30	1.57	1.18	0.53	0.47	12.60	10.63	2.99	17
HLS 210.18.1.4-BR	4.4	$\frac{11}{16}$	Bronze	9.84	8.27	14.17	12.20	1.52	1.77	1.38	0.69	0.59	15.75	13.78	3.39	32
HLS 255.20.1.6-BR	6.6	$\frac{13}{16}$	Bronze	11.81	10.04	15.75	14.17	1.81	1.97	1.57	0.87	0.79	17.72	16.14	3.90	50
HLS 305.22.1.8-BR	8.8	$\frac{7}{8}$	Bronze	13.78	12.01	18.11	16.54	1.81	1.97	1.77	1.02	0.79	20.47	18.90	3.90	70
HLS 345.24.1.10-BR	11.0	$\frac{15}{16}$	Bronze	15.75	13.58	20.87	18.90	2.01	2.36	1.97	1.26	0.79	23.62	21.65	4.45	100

Minimum Ultimate Strength = 4 x WLL

BALL OR CYLINDRICAL ROLLER BEARING

MODEL NO.	WLL (USTONS)	WIRE SIZE (INCH)	BEARING	DIMENSIONS (INCH)											WEIGHT (LBS)	
				$\phi D1$	$\phi D2$	A	B	C	F	ϕG	ϕH	T	TA	TB		TC
HLS 105.10.1.1-BR	1.1	$\frac{3}{8}$	2 x Ball	4.92	4.13	7.09	5.91	0.89	1.06	0.87	0.35	0.31	7.87	6.69	2.13	5
HLS 120.12.1.2-BR	2.2	$\frac{1}{2}$	2 x Ball	5.91	4.72	8.66	7.48	1.22	1.57	1.18	0.43	0.39	9.84	8.66	2.83	10
HLS 165.14.1.3-BR	3.3	$\frac{9}{16}$	2 x Ball	7.87	6.50	11.42	9.45	1.30	1.57	1.18	0.53	0.47	12.60	10.63	2.99	17
HLS 210.18.1.4-BR	4.4	$\frac{11}{16}$	Straight	9.84	8.27	14.17	12.20	1.52	1.77	1.38	0.69	0.59	15.75	13.78	3.39	32
HLS 255.20.1.6-BR	6.6	$\frac{13}{16}$	Straight	11.81	10.04	15.75	14.17	1.81	1.97	1.57	0.87	0.79	17.72	16.14	3.90	50
HLS 305.22.1.8-BR	8.8	$\frac{7}{8}$	Straight	13.78	12.01	18.11	16.54	1.81	1.97	1.77	1.02	0.79	20.47	18.90	3.90	70
HLS 345.24.1.10-BR	11.0	$\frac{15}{16}$	Straight	15.75	13.58	20.87	18.90	2.01	2.36	1.97	1.26	0.79	23.62	21.65	4.45	100

Minimum Ultimate Strength = 4 x WLL

WLL= Working Load Limit on head fitting.

- The indicated WLL is valid at 180° wrap.
- The FoS may decrease in other loading conditions.

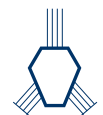

ROPEBLOCK

VERTICAL DIRECTIONAL BLOCKS

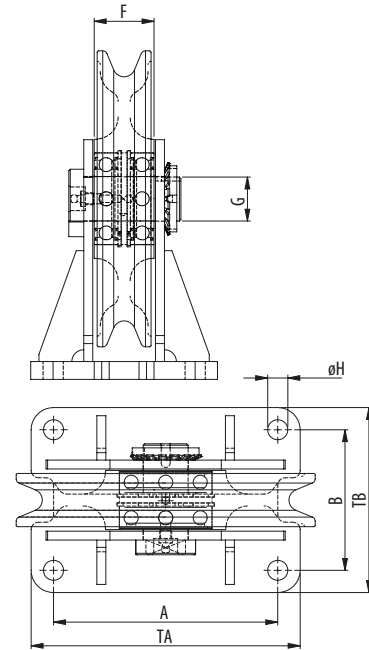
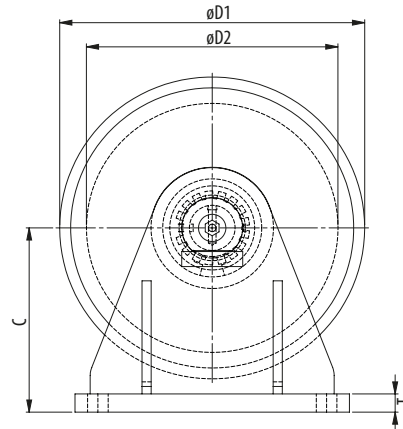

BRONZE BUSHING

Model No.	WLL (UStons)	for wire ϕ d (inch)	Bearing	Dimensions (inch)										Weight (lbs)	
				$\phi D1$	$\phi D2$	A	B	C	F	G	ϕH	T	TA		TB
VLS 105.10.1.1-BR	1.1	$\frac{3}{8}$	Bronze	4.92	4.13	3.54	2.76	3.27	1.06	0.87	0.35	0.31	4.53	3.74	3
VLS 120.12.1.2-BR	2.2	$\frac{1}{2}$	Bronze	5.91	4.72	4.53	3.35	3.74	1.57	1.18	0.43	0.39	5.51	4.33	5
VLS 165.14.1.3-BR	3.3	$\frac{9}{16}$	Bronze	7.87	6.50	5.91	3.74	4.80	1.57	1.18	0.53	0.47	7.09	4.92	8
VLS 210.18.1.4-BR	4.4	$\frac{11}{16}$	Bronze	9.84	8.27	7.48	4.72	6.10	1.77	1.38	0.69	0.59	9.06	6.30	17
VLS 255.20.1.6-BR	6.6	$\frac{13}{16}$	Bronze	11.81	10.04	8.66	5.91	7.28	1.97	1.57	0.87	0.79	10.63	7.87	26
VLS 305.22.1.8-BR	8.8	$\frac{7}{8}$	Bronze	13.78	12.01	10.63	6.30	8.66	1.97	1.77	1.02	0.98	12.99	8.66	41
VLS 345.24.1.10-BR	11.0	$\frac{15}{16}$	Bronze	15.75	13.58	11.81	7.48	10.04	2.36	1.97	1.26	1.18	14.57	10.24	64

Minimum Ultimate Strength = 4 x WLL

BALL OR CYLINDRICAL ROLLER BEARING

Model No.	WLL (UStons)	for wire ϕ d (inch)	Bearing	Dimensions (inch)										Weight (lbs)	
				$\phi D1$	$\phi D2$	A	B	C	F	G	ϕH	T	TA		TB
VLS 105.10.1.1	1.1	$\frac{3}{8}$	2 x Ball	4.92	4.13	3.54	2.76	3.27	1.06	0.87	0.35	0.31	4.53	3.74	7
VLS 120.12.1.2	2.2	$\frac{1}{2}$	2 x Ball	5.91	4.72	4.53	3.35	3.74	1.57	1.18	0.43	0.39	5.51	4.33	11
VLS 165.14.1.3	3.3	$\frac{9}{16}$	2 x Ball	7.87	6.50	5.91	3.74	4.80	1.57	1.18	0.53	0.47	7.09	4.92	18
VLS 210.18.1.4	4.4	$\frac{11}{16}$	Straight	9.84	8.27	7.48	4.72	6.10	1.77	1.38	0.69	0.59	9.06	6.30	37
VLS 255.20.1.6	6.6	$\frac{13}{16}$	Straight	11.81	10.04	8.66	5.91	7.28	1.97	1.57	0.87	0.79	10.63	7.87	57
VLS 305.22.1.8	8.8	$\frac{7}{8}$	Straight	13.78	12.01	10.63	6.30	8.66	1.97	1.77	1.02	0.98	12.99	8.66	90
VLS 345.24.1.10	11.0	$\frac{15}{16}$	Straight	15.75	13.58	11.81	7.48	10.04	2.36	1.97	1.26	1.18	14.57	10.24	141

Minimum Ultimate Strength = 4 x WLL

WLL= Working Load Limit on head fitting.

- The indicated WLL is valid at 180° wrap.
- The FoS may decrease in other loading conditions.



ROPEBLOCK

FLAG DIRECTIONAL BLOCKS

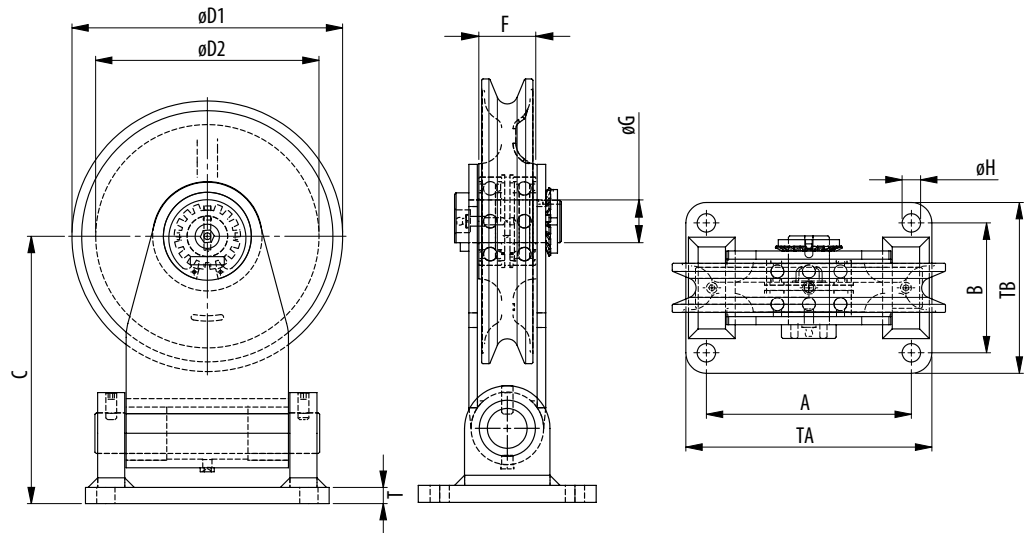

BRONZE BUSHING

Model No.	WLL (UStons)	for wire ød (inch)	Bearing	Dimensions (inch)											Weight (lbs)
				øD1	øD2	A	B	C	F	øG	øH	T	TA	TB	
FLS 105.10.1.1-BR	1.1	3/8	Bronze	4.92	4.13	3.54	2.76	3.27	1.06	0.87	0.35	0.31	4.53	3.74	8
FLS 120.12.1.2-BR	2.2	1/2	Bronze	5.91	4.72	4.53	3.35	3.74	1.57	1.18	0.43	0.39	5.51	4.33	14
FLS 165.14.1.3-BR	3.3	5/16	Bronze	7.87	6.50	5.91	3.74	4.80	1.57	1.18	0.53	0.47	7.09	4.92	24
FLS 210.18.1.4-BR	4.4	1 1/16	Bronze	9.84	8.27	7.48	4.72	6.10	1.77	1.38	0.69	0.59	9.06	6.30	46
FLS 255.20.1.6-BR	6.6	1 3/16	Bronze	11.81	10.04	8.66	5.91	7.28	1.97	1.57	0.87	0.79	10.63	7.87	73
FLS 305.22.1.8-BR	8.8	7/8	Bronze	13.78	12.01	10.63	6.30	8.66	1.97	1.77	1.02	0.98	12.99	8.66	115
FLS 345.24.1.10-BR	11.0	1 5/16	Bronze	15.75	13.58	11.81	7.48	10.04	2.36	1.97	1.26	1.18	14.57	10.24	176

Minimum Ultimate Strength = 4 x WLL

BALL OR CYLINDRICAL ROLLER BEARING

Model No.	WLL (UStons)	for wire ød (inch)	Bearing	Dimensions (inch)											Weight (lbs)
				øD1	øD2	A	B	C	F	øG	øH	T	TA	TB	
FLS 105.10.1.1	1.1	3/8	2 x Ball	4.92	4.13	3.54	2.76	3.27	1.06	0.87	0.35	0.31	4.53	3.74	8
FLS 120.12.1.2	2.2	1/2	2 x Ball	5.91	4.72	4.53	3.35	3.74	1.57	1.18	0.43	0.39	5.51	4.33	14
FLS 165.14.1.3	3.3	5/16	2 x Ball	7.87	6.50	5.91	3.74	4.80	1.57	1.18	0.53	0.47	7.09	4.92	24
FLS 210.18.1.4	4.4	1 1/16	Straight	9.84	8.27	7.48	4.72	6.10	1.77	1.38	0.69	0.59	9.06	6.30	46
FLS 255.20.1.6	6.6	1 3/16	Straight	11.81	10.04	8.66	5.91	7.28	1.97	1.57	0.87	0.79	10.63	7.87	73
FLS 305.22.1.8	8.8	7/8	Straight	13.78	12.01	10.63	6.30	8.66	1.97	1.77	1.02	0.98	12.99	8.66	115
FLS 345.24.1.10	11.0	1 5/16	Straight	15.75	13.58	11.81	7.48	10.04	2.36	1.97	1.26	1.18	14.57	10.24	176

Minimum Ultimate Strength = 4 x WLL

WLL= Working Load Limit on head fitting.

- The indicated WLL is valid at 180° wrap and 0° swing. The FoS may decrease in other loading conditions.

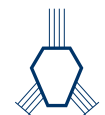

ROPEBLOCK

DUCTILE CAST IRON SHEAVES

WITH CYLINDRICAL ROLLER BEARINGS

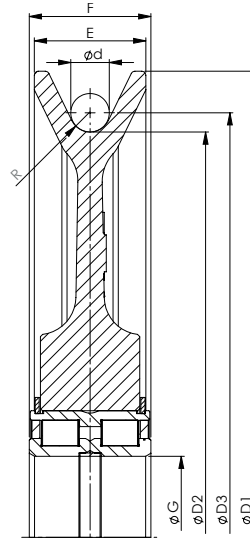

MODEL NO.	FOR WIRE ØD		DIMENSIONS (INCH)							BEARING	WEIGHT (KG)	WEIGHT (LBS)
	MM	INCH	R	ØD1	ØD2	ØD3	E	F	ØG			
SE.250.5008B.5,5	10	3/8	0.22	11.42	9.84	10.24	1.26	1.50	1.57	SLO4 5008PP	5.9	12.98
SE.250.5008B.6	11	7/16	0.24	11.42	9.84	10.28	1.26	1.50	1.57	SLO4 5008PP	5.8	12.76
SE.280.5012.7	13	1/2	0.28	12.60	11.02	11.54	1.65	1.81	2.36	SLO4 5012PP	9.4	20.68
SE.280.5010B.7	13	1/2	0.28	12.60	11.02	11.54	1.42	1.57	1.97	SLO4 5010PP	8.1	17.82
SE.280.5010.7	13	1/2	0.28	12.60	11.02	11.54	1.42	1.57	1.97	SLO4 5010PP	8.1	17.82
SE.250.5008B.7,2	13	1/2	0.28	11.42	9.84	10.35	1.26	1.50	1.57	SLO4 5008PP	6.2	13.64
SE.260.5012.7,5	14	9/16	0.30	11.81	10.24	10.79	1.65	1.81	2.36	SLO4 5012PP	9.6	21.12
SE.280.5012.8	15	9/16	0.31	12.60	11.02	11.61	1.65	1.81	2.36	SLO4 5012PP	9.2	20.24
SE.400.5013.8,5	16	5/8	0.33	18.11	15.75	16.38	1.69	1.81	2.56	SLO4 5013PP	25.4	55.88
SE.360.5016.8,5	16	5/8	0.33	16.54	14.17	14.80	2.17	2.36	3.15	SLO4 5016PP	21.9	48.18
SE.355.5013.8,5	16	5/8	0.33	16.14	13.98	14.61	1.65	1.81	2.56	SLO4 5013PP	18.3	40.26
SE.320.5013.8,5	16	5/8	0.33	14.37	12.60	13.23	1.65	1.81	2.56	SLO4 5013PP	13.5	29.7
SE.295.5008B.8,5	16	5/8	0.33	12.99	11.61	12.24	1.26	1.50	1.57	SLO4 5008PP	8.8	19.36
SE.280.5012.8,5	16	5/8	0.33	12.60	11.02	11.65	1.65	1.81	2.36	SLO4 5012PP	9.1	20.02
SE.260.5012.8,5	16	5/8	0.33	11.81	10.24	10.87	1.65	1.81	2.36	SLO4 5012PP	9.1	20.02
SE.355.5013.9	17	1 1/16	0.35	16.14	13.98	14.65	1.65	1.81	2.56	SLO4 5013PP	18.1	39.82
SE.400.5014B.9,5	18	1 1/16	0.37	18.11	15.75	16.46	1.93	2.13	2.76	SLO4 5014PP	25.4	55.88
SE.400.5013.9,5	18	1 1/16	0.37	18.11	15.75	16.46	1.69	1.81	2.56	SLO4 5013PP	25	55
SE.360.5016.9,5	18	1 1/16	0.37	16.54	14.17	14.88	2.17	2.36	3.15	SLO4 5016PP	21.6	47.52
SE.355.5013.9,5	18	1 1/16	0.37	16.14	13.98	14.69	1.65	1.81	2.56	SLO4 5013PP	18	39.6
SE.354.5013.9,5	18	1 1/16	0.37	15.75	13.94	14.65	1.65	1.81	2.56	SLO4 5013PP	16.5	36.3
SE.345.5010B.9,5	18	1 1/16	0.37	15.16	13.58	14.29	1.42	1.57	1.97	SLO4 5010PP	12.5	27.5
SE.450.5024.10	19	3/4	0.39	20.28	17.72	18.46	2.95	3.15	4.72	SLO4 5024PP	47.9	105.38
SE.450.5018.10	19	3/4	0.39	20.28	17.72	18.46	2.44	2.64	3.54	SLO4 5018PP	41.4	91.08
SE.450.160.10	19	3/4	0.39	20.28	17.72	18.46	2.95	3.15	6.30	SLO4 160PP	45.4	99.88

- The dimensions in this table are indicative only. A drawing will always be submitted prior to production and will be the leading document when discussing dimensions.
- Sheaves shown here are standard models; inquiries for custom versions are welcome.



DUCTILE CAST IRON SHEAVES WITH CYLINDRICAL ROLLER BEARINGS

MODEL NO.	FOR WIRE ØD		DIMENSIONS (INCH)							BEARING	WEIGHT (KG)	WEIGHT (LBS)
	MM	INCH	R	ØD1	ØD2	ØD3	E	F	ØG			
SE.400.5018.10	19	¾	0.39	18.11	15.75	16.50	2.44	2.64	3.54	SLO4 5018PP	31	68.2
SE.400.5016.10	19	¾	0.39	18.11	15.75	16.50	2.17	2.36	3.15	SLO4 5016PP	28.8	63.36
SE.400.5013.10	19	¾	0.39	18.11	15.75	16.50	1.69	1.81	2.56	SLO4 5013PP	24.8	54.56
SE.360.5016.10	19	¾	0.39	16.54	14.17	14.92	2.17	2.36	3.15	SLO4 5016PP	17.9	39.38
SE.355.5016.10	19	¾	0.39	16.14	13.98	14.72	2.17	2.36	3.15	SLO4 5016PP	16.8	36.96
SE.355.5013.10	19	¾	0.39	16.14	13.98	14.72	1.65	1.81	2.56	SLO4 5013PP	17.8	39.16
SE.345.5010B.10	19	¾	0.39	15.16	13.58	14.33	1.42	1.57	1.97	SLO4 5010PP	12.5	27.5
SE.320.5013.10	19	¾	0.39	14.37	12.60	13.35	1.65	1.81	2.56	SLO4 5013PP	13.2	29.04
SE.280.5012.10	19	¾	0.39	12.60	11.02	11.77	1.65	1.81	2.36	SLO4 5012PP	10.3	22.66
SE.482.5018.11,5	21	13/16	0.45	22.05	18.98	19.80	2.44	2.64	3.54	SLO4 5018PP	45.5	100.1
SE.400.5018.11,5	21	13/16	0.45	18.11	15.75	16.57	2.44	2.64	3.54	SLO4 5018PP	30.4	66.88
SE.400.5016.11,5	21	13/16	0.45	18.11	15.75	16.57	2.17	2.36	3.15	SLO4 5016PP	28.3	62.26
SE.400.5014B.11,5	21	13/16	0.45	18.11	15.75	16.57	1.93	2.13	2.76	SLO4 5014PP	24.7	54.34
SE.450.5024.12	22	7/8	0.47	20.28	17.72	18.58	2.95	3.15	4.72	SLO4 5024PP	47	103.4
SE.450.5018.12	22	7/8	0.47	20.28	17.72	18.58	2.44	2.64	3.54	SLO4 5018PP	40.5	89.1
SE.400.5018.12	22	7/8	0.47	18.11	15.75	16.61	2.44	2.64	3.54	SLO4 5018PP	30.2	66.44
SE.400.5016.12	22	7/8	0.47	18.11	15.75	16.61	2.17	2.36	3.15	SLO4 5016PP	28.1	61.82
SE.355.5016.12	22	7/8	0.47	16.14	13.98	14.84	2.17	2.36	3.15	SLO4 5016PP	16.8	36.96
SE.528.5018.13	24	15/16	0.51	23.43	20.79	21.73	2.40	2.64	3.54	SLO4 5018PP	50.9	111.98
SE.528.200.13	24	15/16	0.51	23.43	20.79	21.73	2.91	3.15	7.87	SLO4 200PP	56.7	124.74
SE.528.160.13	24	15/16	0.51	23.43	20.79	21.73	2.91	3.15	6.30	SLO4 160PP	61.2	134.64
SE.670.200.13,5	25	1	0.53	29.92	26.38	27.36	2.91	3.15	7.87	SLO4 200PP	93.5	205.7
SE.670.160.13,5	25	1	0.53	29.92	26.38	27.36	2.91	3.15	6.30	SLO4 160PP	93.5	205.7
SE.670.5024.13,5	25	1	0.53	29.92	26.38	27.36	2.91	3.15	4.72	SLO4 5024PP	92.6	203.72
SE.528.5024.13,5	25	1	0.53	23.43	20.79	21.77	2.91	3.15	4.72	SLO4 5024PP	57.8	127.16
SE.528.5018.13,5	25	1	0.53	23.43	20.79	21.77	2.40	2.64	3.54	SLO4 5018PP	50.6	111.32
SE.528.160.13,5	25	1	0.53	23.43	20.79	21.77	2.91	3.15	6.30	SLO4 160PP	53.5	117.7
SE.500.5018B.13,5	25	1	0.53	22.44	19.69	20.71	2.40	2.64	3.54	SLO4 5018PP	46.8	102.96
SE.450.5024.13,5	25	1	0.53	20.28	17.72	18.70	2.95	3.15	4.72	SLO4 5024PP	46.3	101.86
SE.450.5018.13,5	25	1	0.53	20.28	17.72	18.70	2.44	2.64	3.54	SLO4 5018PP	39.8	87.56
SE.575.5024.14	26	1	0.55	25.59	22.64	23.66	2.91	3.15	4.72	SLO4 5024PP	72.6	159.72
SE.575.5022.14	26	1	0.55	25.59	22.64	23.66	2.91	3.15	4.33	SLO4 5022PP	73.5	161.7
SE.575.200.14	26	1	0.55	25.59	22.64	23.66	2.91	3.15	7.87	SLO4 200PP	76.7	168.74
SE.575.160.14	26	1	0.55	25.59	22.64	23.66	2.91	3.15	6.30	SLO4 160PP	72	158.4
SE.528.5024.14	26	1	0.55	23.43	20.79	21.81	2.91	3.15	4.72	SLO4 5024PP	63.5	139.7
SE.528.5018.14	26	1	0.55	23.43	20.79	21.81	2.40	2.64	3.54	SLO4 5018PP	45.4	99.88
SE.528.160.14	26	1	0.55	23.43	20.79	21.81	2.91	3.15	6.30	SLO4 160PP	53.2	117.04
SE.670.200.15	28	1 1/8	0.59	29.92	26.38	27.48	2.91	3.15	7.87	SLO4 200PP	97	213.4
SE.670.160.15	28	1 1/8	0.59	29.92	26.38	27.48	2.91	3.15	6.30	SLO4 160PP	92.2	202.84
SE.670.5024.15	28	1 1/8	0.59	29.92	26.38	27.48	2.91	3.15	4.72	SLO4 5024PP	91.3	200.86
SE.630.200.15	28	1 1/8	0.59	27.95	24.80	25.91	2.91	3.15	7.87	SLO4 200PP	87.7	192.94

- The dimensions in this table are indicative only. A drawing will always be submitted prior to production and will be the leading document when discussing dimensions.
- Sheaves shown here are standard models; inquiries for custom versions are welcome.

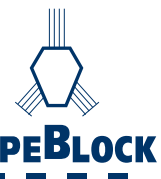

DUCTILE CAST IRON SHEAVES

WITH CYLINDRICAL ROLLER BEARINGS

MODEL NO.	FOR WIRE ØD		DIMENSIONS (INCH)							BEARING	WEIGHT (KG)	WEIGHT (LBS)
	MM	INCH	R	ØD1	ØD2	ØD3	E	F	ØG			
SE.630.160.15	28	1 1/8	0.59	27.95	24.80	25.91	2.91	3.15	6.30	SL04 160PP	82.8	182.16
SE.630.5024.15	28	1 1/8	0.59	27.95	24.80	25.91	2.91	3.15	4.72	SL04 5024PP	84.4	185.68
SE.575.5024.15	28	1 1/8	0.59	25.59	22.64	23.74	2.91	3.15	4.72	SL04 5024PP	72	158.4
SE.575.200.15	28	1 1/8	0.59	25.59	22.64	23.74	2.91	3.15	7.87	SL04 200PP	76.1	167.42
SE.575.160.15	28	1 1/8	0.59	25.59	22.64	23.74	2.91	3.15	6.30	SL04 160PP	71.4	157.08
SE.528.5024.15	28	1 1/8	0.59	23.43	20.79	21.89	2.91	3.15	4.72	SL04 5024PP	57	125.4
SE.528.5018.15	28	1 1/8	0.59	23.43	20.79	21.89	2.40	2.64	3.54	SL04 5018PP	49.9	109.78
SE.528.200.15	28	1 1/8	0.59	23.43	20.79	21.89	2.91	3.15	7.87	SL04 200PP	64.9	142.78
SE.528.160.15	28	1 1/8	0.59	23.43	20.79	21.89	2.83	3.15	6.30	SL04 160PP	52.7	115.94
SE.450.5024.15	28	1 1/8	0.59	20.28	17.72	18.82	2.95	3.15	4.72	SL04 5024PP	45.6	100.32
SE.450.5018.15	28	1 1/8	0.59	20.28	17.72	18.82	2.44	2.64	3.54	SL04 5018PP	39.2	86.24
SE.630.200.16	30	1 3/16	0.63	27.95	24.80	25.98	2.91	3.15	7.87	SL04 200PP	87	191.4
SE.630.160.16	30	1 3/16	0.63	27.95	24.80	25.98	2.91	3.15	6.30	SL04 160PP	82.1	180.62
SE.630.5024.16	30	1 3/16	0.63	27.95	24.80	25.98	2.91	3.15	4.72	SL04 5024PP	83.7	184.14
SE.630.5022B.16	30	1 3/16	0.63	27.95	24.80	25.98	2.91	3.15	4.33	SL04 5022PP	83.5	183.7
SE.575.5022.16	30	1 3/16	0.63	25.59	22.64	23.82	2.91	3.15	4.33	SL04 5022PP	72.3	159.06
SE.800.5022.16	31	1 1/4	0.63	35.04	31.50	32.68	2.76	3.15	4.33	SL04 5022PP	136.5	300.3
SE.800.5026.17	32	1 1/4	0.67	35.04	31.50	32.76	2.95	3.74	5.12	SL04 5026PP	129.9	285.78
SE.710.5022.17	32	1 1/4	0.67	31.50	27.95	29.21	2.83	3.15	4.33	SL04 5022PP	99.8	219.56
SE.670.200.17	32	1 1/4	0.67	29.92	26.38	27.64	2.91	3.15	7.87	SL04 200PP	95.3	209.66
SE.670.160.17	32	1 1/4	0.67	29.92	26.38	27.64	2.91	3.15	6.30	SL04 160PP	90.5	199.1
SE.670.5024.17	32	1 1/4	0.67	29.92	26.38	27.64	2.91	3.15	4.72	SL04 5024PP	89.7	197.34
SE.630.200.17	32	1 1/4	0.67	27.95	24.80	26.06	2.91	3.15	7.87	SL04 200PP	86.3	189.86
SE.630.160.17	32	1 1/4	0.67	27.95	24.80	26.06	2.91	3.15	6.30	SL04 160PP	81.4	179.08
SE.630.5024.17	32	1 1/4	0.67	27.95	24.80	26.06	2.91	3.15	4.72	SL04 5024PP	83	182.6
SE.575.5024.17	32	1 1/4	0.67	25.59	22.64	23.90	2.91	3.15	4.72	SL04 5024PP	70.9	155.98
SE.710.5026.18	34	1 5/16	0.71	31.50	27.95	29.29	3.07	3.74	5.12	SL04 5026PP	98.3	216.26
SE.710.5022.18	34	1 5/16	0.71	31.50	27.95	29.29	2.83	3.15	4.33	SL04 5022PP	98.7	217.14
SE.800.5028.19	36	1 7/16	0.71	35.04	31.50	32.91	3.35	3.74	5.51	SL04 5028PP	152.4	335.28
SE.800.5030.20	38	1 1/2	0.71	35.04	31.50	32.99	3.54	3.94	5.91	SL04 5030PP	153	336.6
SE.800.5028.20	38	1 1/2	0.71	35.04	31.50	32.99	3.35	3.74	5.51	SL04 5028PP	151.4	333.08
SE.800.5026.20	38	1 1/2	0.71	35.04	31.50	32.99	2.95	3.74	5.12	SL04 5026PP	133.5	293.7
SE.800.5024.20	38	1 1/2	0.71	35.04	31.50	32.99	2.76	3.15	4.72	SL04 5024PP	127.1	279.62
SE.760.5030.20	38	1 1/2	0.71	33.86	29.92	31.42	3.35	3.94	5.91	SL04 5030PP	134.2	295.24
SE.710.5024.20	38	1 1/2	0.71	31.50	27.95	29.45	2.83	3.15	4.72	SL04 5024PP	94.5	207.9
SE.760.5026.20,5	39	1 5/16	0.81	33.86	29.92	31.46	2.95	3.74	5.12	SL04 5026PP	138.2	304.04
SE.800.5030.21	40	1 5/16	0.83	35.04	31.50	33.07	3.54	3.94	5.91	SL04 5030PP	152.4	335.28
SE.800.5028.21	40	1 5/16	0.83	35.04	31.50	33.07	3.35	3.74	5.51	SL04 5028PP	150.4	330.88
SE.800.5030.22,5	42	1 5/8	0.89	35.04	31.50	33.15	3.54	3.94	5.91	SL04 5030PP	160.1	352.22
SE.800.5028.22,5	42	1 5/8	0.89	35.04	31.50	33.15	3.35	3.74	5.51	SL04 5028PP	149	327.8
SE.800.5030.23,5	44	1 3/4	0.93	35.04	31.50	33.23	3.54	3.94	5.91	SL04 5030PP	149.6	329.12

- The dimensions in this table are indicative only. A drawing will always be submitted prior to production and will be the leading document when discussing dimensions.
- Sheaves shown here are standard models; inquiries for custom versions are welcome.

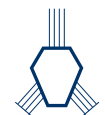

ROPEBLOCK

POLYAMID SHEAVES WITH CYLINDRICAL ROLLER BEARINGS

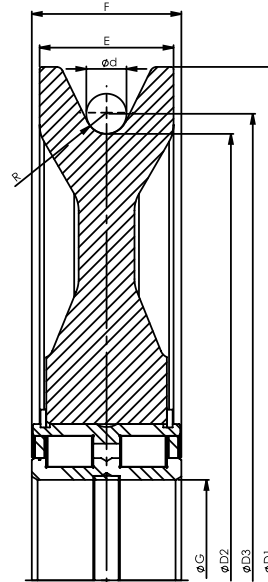

MODEL NO.	FOR WIRE ØD		DIMENSIONS (INCH)							BEARING	MATERIAL	WEIGHT (KG)	WEIGHT (LBS)
	MM	INCH	R	ØD1	ØD2	ØD3	E	F	ØG				
SE.260.5010.7.K	12	½	0.28	11.81	10.24	10.71	1.34	1.57	1.97	SL04 5010PP	PA 6G	2.86	6.29
SE.285.5012.7.K	12	½	0.28	12.80	11.22	11.69	1.34	1.81	2.36	SL04 5012PP	PA 6G	3.86	8.49
SE.352.5013.8,5.K	16	⅝	0.33	15.75	13.86	14.49	1.65	1.81	2.56	SL04 5013PP	PA 6G	5.63	12.39
SE.352.5016.8,5.K	16	⅝	0.33	15.75	13.86	14.49	1.97	2.36	3.15	SL04 5016PP	PA 6G	7.61	16.74
SE.400.5018.9,5.K	18	⅞	0.37	18.11	15.75	16.46	2.36	2.64	3.54	SL04 5018PP	PA 6G	10.81	23.78
SE.400.5024.9,5.K	18	⅞	0.37	18.11	15.75	16.46	2.83	3.15	4.72	SL04 5024PP	PA 6G	14.04	30.89
SE.400.160.9,5.K	18	⅞	0.37	18.11	15.75	16.46	2.83	3.15	6.30	SL04 160PP	PA 6G	13.54	29.79
SE.482.5018.11,4.K	21	1⅜	0.45	22.05	18.98	19.80	2.44	2.64	3.54	SL04 5018PP	PA 6G	14.01	30.82
SE.482.5024.11,4.K	21	1⅜	0.45	22.05	18.98	19.80	2.83	3.15	4.72	SL04 5024PP	PA 6G	17.54	38.59
SE.482.160.11,4.K	21	1⅜	0.45	22.05	18.98	19.80	2.83	3.15	6.30	SL04 160PP	PA 6G	17.2	37.84
SE.528.5018.12.K	22	⅞	0.47	23.46	20.79	21.65	2.36	2.64	3.54	SL04 5018PP	PA 6G	15.01	33.02
SE.528.5024.13.K	24	1⅝	0.51	23.46	20.79	21.73	2.83	3.15	4.72	SL04 5024PP	PA 6G	20.9	45.98
SE.528.160.13.K	24	1⅝	0.51	23.46	20.79	21.73	2.83	3.15	4.72	SL04 160PP	PA 6G	22.1	48.62

- The dimensions in this table are indicative only. A drawing will always be submitted prior to production and will be the leading document when discussing dimensions.
- Sheaves shown here are standard models; inquiries for custom versions are welcome.

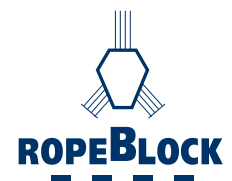

SINGLE HOOK

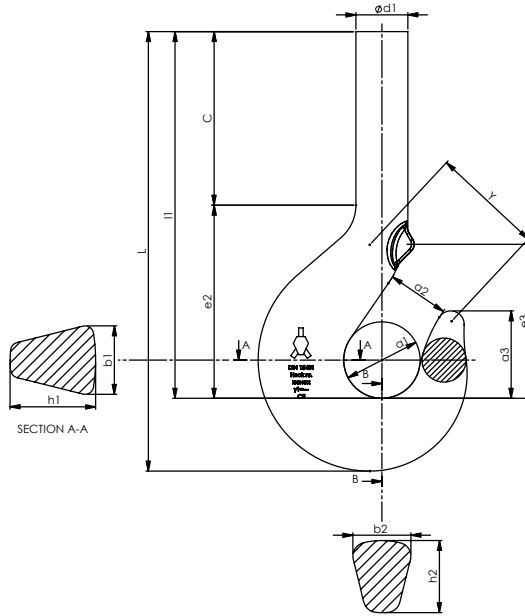

HOOK NO.	LIFTING CAPACITY US TONS V-CLASS HOOK	LIFTING CAPACITY METRIC TONS V-CLASS HOOK	LIFTING CAPACITY US TONS T-CLASS HOOK	LIFTING CAPACITY METRIC TONS T-CLASS HOOK	LIFTING CAPACITY US TONS P-CLASS HOOK	LIFTING CAPACITY METRIC TONS P-CLASS HOOK	DIMENSIONS (INCH)														WEIGHT (KG)	WEIGHT (LBS)
							A1	A2	A3	B1	B2	C	ØD1	E2	E3	H1	H2	L	L1	Y		
1,6	8.8	8	6.93	6.3	4.4	4	2.20	1.77	2.52	1.77	1.50	2.52	1.42	5.75	4.65	2.20	1.89	10.47	8.27	2.95	5	10
2,5	13.75	12.5	11	10	6.93	6.3	2.48	1.97	2.83	2.09	1.77	3.46	1.65	6.57	5.20	2.64	2.28	12.68	10.04	3.15	6	14
4	22	20	17.6	16	11	10	2.80	2.20	3.15	2.48	2.09	5.51	1.89	7.48	5.83	3.15	2.64	16.14	12.99	5.12	10	22
5	27.5	25	22	20	13.75	12.5	3.15	2.48	3.54	2.80	2.36	7.28	2.09	8.46	6.50	3.54	2.95	19.29	15.75	5.12	15	33
6	35.2	32	27.5	25	17.6	16	3.54	2.80	3.98	3.15	2.64	7.28	2.36	9.45	7.28	3.94	3.35	20.67	16.73	5.12	21	47
8	44	40	35.2	32	22	20	3.94	3.15	4.45	3.54	2.95	7.95	2.64	10.55	8.27	4.41	3.74	22.91	18.50	5.71	30	66
10	55	50	44	40	27.5	25	4.41	3.54	5.00	3.94	3.35	10.59	2.95	11.26	8.70	4.92	4.17	26.77	21.85	6.30	42	93
12	69.3	63	55	50	35.2	32	4.92	3.94	5.63	4.41	3.74	11.18	3.35	12.44	9.92	5.51	4.65	29.13	23.62	7.09	59	129
16	88	80	69.3	63	44	40	5.51	4.41	6.30	4.92	4.17	11.93	3.74	14.06	11.02	6.30	5.20	32.28	25.98	7.87	82	180
20	110	100	88	80	55	50	6.30	4.92	7.09	5.51	4.65	16.34	4.17	15.94	12.99	7.09	5.91	39.37	32.28	8.86	123	270
25	137.5	125	110	100	69.3	63	7.09	5.51	7.95	6.30	5.20	17.52	4.65	17.91	14.17	7.87	6.69	43.31	35.43	10.04	173	382
32	176	160	137.5	125	88	80	7.87	6.30	8.86	7.09	5.91	19.29	5.20	20.08	15.75	8.82	7.48	48.19	39.37	11.42	238	524
40	220	200	176	160	110	100	8.82	7.09	9.92	7.87	6.69	19.02	5.91	22.32	17.60	9.84	8.35	51.18	41.34	12.60	326	719
50	275	250	220	200	137.5	125	9.84	7.87	11.22	8.82	7.48	19.88	6.69	25.00	19.09	11.02	9.29	55.91	44.88	13.98	455	1003
63	352	320	275	250	176	160	11.02	8.82	12.60	9.84	8.35	23.23	7.48	27.95	21.65	12.40	10.43	63.58	51.18	15.75	643	1418
80	440	400	352	320	220	200	12.40	9.84	14.09	11.02	9.29	17.64	8.35	31.57	23.54	13.98	11.81	63.19	49.21	17.72	760	1676
100	550	500	440	400	275	250	13.98	11.02	15.83	12.40	10.43	20.20	9.29	35.51	27.09	15.75	13.19	71.46	55.71	19.88	1220	2690
125	693	630	550	500	352	320	15.75	12.40	17.72	13.98	11.81	23.62	10.43	40.16	29.53	17.72	14.76	81.50	63.78	22.44	1750	3858
160	880	800	693	630	440	400	17.72	13.98	19.88	15.75	13.19	25.39	11.81	45.08	32.48	19.69	16.73	90.16	70.47	25.20	2480	5467
200	1100	1000	880	800	550	500	19.69	15.75	22.24	17.72	14.76	30.43	13.19	50.20	35.43	22.05	18.70	102.68	80.63	28.35	3420	7540
250	1375	1250	1100	1000	693	630	22.05	17.72	25.00	19.69	16.73	34.45	14.76	56.30	38.58	24.80	20.87	115.55	90.75	31.89	4800	10582

- Hooks shown here are standard models; inquiries for custom versions are welcome.
- Lifting capacity determined according to crane group 1Bm as specified in DIN 15400.



DOUBLE HOOK

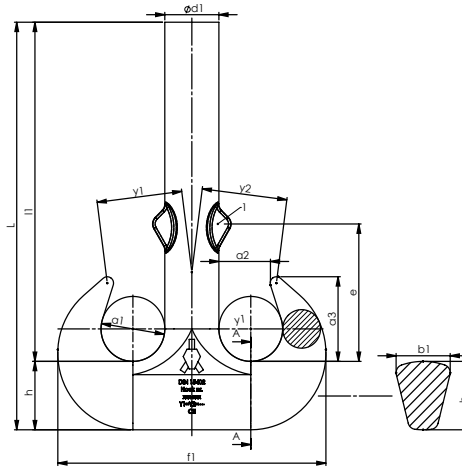

HOOK NO.	LIFTING CAPACITY US TONS V-CLASS HOOK	LIFTING CAPACITY METRIC TONS V-CLASS HOOK	LIFTING CAPACITY US TONS T-CLASS HOOK	LIFTING CAPACITY METRIC TONS T-CLASS HOOK	LIFTING CAPACITY US TONS P-CLASS HOOK	LIFTING CAPACITY METRIC TONS P-CLASS HOOK	DIMENSIONS (INCH)										WEIGHT (KG)	WEIGHT (LBS)	
							A1	A2	A3	B1	ØD1	E	F1	H	L	L1			Y1=Y2
1,6	8.8	8	6,93	6,3	4,4	4	1.77	1.42	2.32	1.34	1.42	3.94	7.20	1.69	10.43	8.74	2.36	5	12
2,5	13.75	12.5	11	10	6.93	6,3	1.97	1.57	2.56	1.57	1.65	4.41	8.19	1.97	11.81	9.84	2.56	7	15
4	22	20	17.6	16	11	10	2.20	1.77	2.87	1.89	1.89	4.88	9.37	2.36	15.35	12.99	3.66	10	22
5	27.5	25	22	20	13.75	12,5	2.48	1.97	3.23	2.09	2.09	5.63	10.47	2.64	14.65	12.01	3.66	13	28
6	35.2	32	27,5	25	17.6	16	2.80	2.20	3.62	2.36	2.36	6.30	11.85	2.95	19.88	16.93	3.66	18	39
8	44	40	35,2	32	22	20	3.15	2.48	4.06	2.64	2.64	7.17	13.27	3.35	21.06	17.72	4.11	26	58
10	55	50	44	40	27.5	25	3.54	2.80	4.57	2.95	2.95	7.56	14.84	3.74	23.03	19.29	4.63	35	77
12	69.3	63	55	50	35.2	32	3.94	3.15	5.12	3.35	3.35	8.27	16.57	4.17	24.25	20.08	5.22	49	108
16	88	80	69.3	63	44	40	4.41	3.54	5.75	3.74	3.74	9.33	18.54	4.65	28.27	23.62	5.85	60	132
20	110	100	88	80	55	50	4.92	3.94	6.42	4.17	4.17	10.43	20.91	5.20	33.54	28.35	6.52	97	214
25	137.5	125	110	100	69.3	63	5.51	4.41	7.17	4.65	4.65	12.40	23.54	5.91	39.37	33.46	7.28	135	298
32	176	160	137.5	125	88	80	6.30	4.92	8.07	5.20	5.20	13.19	26.46	6.69	40.16	33.46	8.15	193	425
40	220	200	176	160	110	100	7.09	5.51	9.06	5.91	5.91	14.76	29.69	7.48	47.83	40.35	9.17	280	617
50	275	250	220	200	137.5	125	7.87	6.30	10.24	6.69	6.69	16.54	33.15	8.35	51.65	43.31	10.43	338	745
63	352	320	275	250	176	160	8.82	7.09	11.50	7.48	7.48	18.11	37.17	9.29	56.54	47.24	11.69	539	1188
80	440	400	352	320	220	200	9.84	7.87	12.80	8.35	8.35	20.28	41.81	10.43	59.65	49.21	13.03	760	1676
100	550	500	440	400	275	250	11.02	8.82	14.33	9.29	9.29	22.64	46.69	11.81	67.91	56.10	14.57	1100	2425
125	693	630	550	500	352	320	12.40	9.84	16.06	10.43	10.43	25.39	52.36	13.19	74.21	61.02	16.32	1491	3287
160	880	800	693	630	440	400	13.98	11.02	18.03	11.81	11.81	28.54	59.25	14.76	83.46	68.70	18.35	2115	4663
200	1100	1000	880	800	550	500	15.75	12.40	20.28	13.19	13.19	31.50	66.34	16.73	95.39	78.66	20.7	3015	6647
250	1375	1250	1100	1000	693	630	17.72	13.98	22.83	14.76	14.76	34.45	74.21	18.70	107.28	88.58	23.13	4268	9409

- Hooks shown here are standard models; inquiries for custom versions are welcome.
- Lifting capacity determined according to crane group 1Bm as specified in DIN 15400.

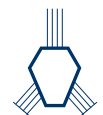

ROPEBLOCK

DOUBLE HOOK WITH SHACKLE HOLE

FORM B

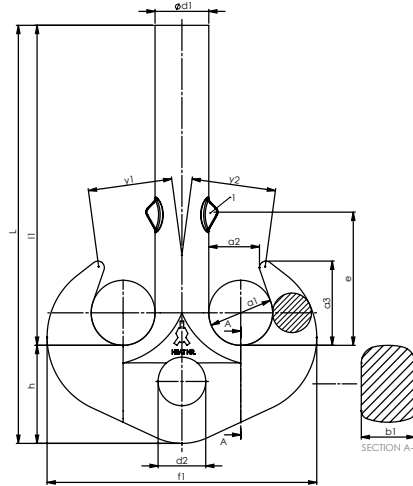

HOOK NO.	LIFTING CAPACITY US TONS V-CLASS HOOK	LIFTING CAPACITY METRIC TONS V-CLASS HOOK	LIFTING CAPACITY US TONS T-CLASS HOOK	LIFTING CAPACITY METRIC TONS T-CLASS HOOK	LIFTING CAPACITY US TONS P-CLASS HOOK	LIFTING CAPACITY METRIC TONS P-CLASS HOOK	DIMENSIONS (INCH)											WEIGHT (KG)	WEIGHT (LBS)	
							A1	A2	A3	B1	ØD1	D2 (H15)	E	F1	H	L	L1			Y1=Y2
8	44	40	35,2	32	22	20	3.15	2.48	4.06	2.64	2.64	2.91	7.17	13.27	4.72	21.06	16.34	4.11	30	66
10	55	50	44	40	27.5	25	3.54	2.80	4.57	2.95	2.95	2.91	7.56	14.84	5.12	22.83	17.72	4.63	41	90
12	69.3	63	55	50	35.2	32	3.94	3.15	5.12	3.35	3.35	3.07	8.27	16.57	5.91	25.98	20.08	5.22	57	126
16	88	80	69.3	63	44	40	4.41	3.54	5.75	3.74	3.74	3.39	9.33	18.54	6.69	29.53	22.83	5.85	82	181
20	110	100	88	80	55	50	4.92	3.94	6.42	4.17	4.17	3.78	10.43	20.91	7.48	33.07	25.59	6.52	115	254
25	137.5	125	110	100	69.3	63	5.51	4.41	7.17	4.65	4.65	4.17	12.40	23.54	8.35	36.50	28.15	7.28	160	353
32	176	160	137.5	125	88	80	6.30	4.92	8.07	5.20	5.20	4.57	13.19	26.46	9.29	40.39	31.10	8.15	229	505
40	220	200	176	160	110	100	7.09	5.51	9.06	5.91	5.91	5.16	14.76	29.69	10.43	45.28	34.84	9.17	330	728
50	275	250	220	200	137.5	125	7.87	6.30	10.24	6.69	6.69	5.75	16.54	33.15	11.81	49.80	37.99	10.43	458	1010
63	352	320	275	250	176	160	8.82	7.09	11.50	7.48	7.48	6.61	18.11	37.17	13.19	56.10	42.91	11.69	638	1407
80	440	400	352	320	220	200	9.84	7.87	12.80	8.35	8.35	7.40	20.28	41.81	14.76	63.39	48.62	13.03	892	1967
100	550	500	440	400	275	250	11.02	8.82	14.33	9.29	9.29	8.19	22.64	46.69	16.73	70.87	54.13	14.57	1248	2751
125	693	630	550	500	352	320	12.40	9.84	16.06	10.43	10.43	9.25	25.39	52.36	18.70	79.72	61.02	16.32	1757	3874
160	880	800	693	630	440	400	13.98	11.02	18.03	11.81	11.81	10.24	28.54	59.25	20.87	89.57	68.70	18.35	2500	5512
200	1100	1000	880	800	550	500	15.75	12.40	20.28	13.19	13.19	11.10	31.50	66.34	23.62	100.79	77.17	20.57	3560	7848
250	1375	1250	1100	1000	693	630	17.72	13.98	22.83	14.76	14.76	12.28	34.45	74.21	26.38	113.39	87.01	23.13	5033	11096

- Hooks shown here are standard models; inquiries for custom versions are welcome.
- Lifting capacity determined according to crane group 1Bm as specified in DIN 15400.

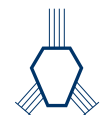

ROPEBLOCK

LATCHES

SINGLE HOOK	STANDARD HOOK LATCH	STANDARD HOOK LATCH WITH LOCKING PIN	HEAVY DUTY HOOK LATCH WITH LOCKING PIN	DIMENSIONS (INCH)
				Ø
1,6	64.1,6.E	on request	on request	1.57
2,5	64.2,5.E	on request	64.2,5.E.B	1.61
4	64.4.E	on request	64.4.E.B	1.93
5	64.5.E	64.5.E.F	64.5.E.B	2.17
6	64.6.E	64.6.E.F	64.6.E.B	2.32
8	64.8.E	64.8.E.F	64.8.E.B	2.72
10	64.10.E	64.10.E.F	64.10.E.B	2.99
12	64.12.E	64.12.E.F	64.12.E.B	3.31
16	64.16.E	64.16.E.F	64.16.E.B	3.82
20	64.20.E	64.20.E.F	64.20.E.B	4.33
25	64.25.E	64.25.E.F	64.25.E.B	5.2
32	64.32.E	64.32.E.F	64.32.E.B	5.39
40	64.40.E	64.40.E.F	64.40.E.B	6.57
50	64.50.E	64.50.E.F	64.50.E.B	7.4
63	64.63.E	64.63.E.F	64.63.E.B	8.07
80	64.80.E	on request	64.80.E.B	8.98
100	64.100.E	on request	64.100.E.B	10.03
125	64.125.E	on request	on request	11.41
160	on request	on request	on request	on request
200	on request	on request	on request	on request
250	on request	on request	on request	on request



SINGLE HOOK	STANDARD HOOK LATCH	STANDARD HOOK LATCH WITH LOCKING PIN	HEAVY DUTY HOOK LATCH WITH LOCKING PIN	DIMENSIONS (INCH)
				Ø
2,5	64.1,6.E	on request	on request	1.18
4	64.2,5.E	on request	64.2,5.E.B	1.22
5	64.4.E	64.5.D.F	64.4.E.B	1.5
6	64.5.E	64.6.D.F	64.5.E.B	1.89
8	64.6.E	64.8.D.F	64.6.E.B	1.85
10	64.8.E	64.10.D.F	64.8.E.B	2.24
12	64.10.E	64.12.D.F	64.10.E.B	2.36
16	64.12.E	64.16.D.F	64.12.E.B	2.48
20	64.16.E	64.20.D.F	64.16.E.B	2.87
25	64.20.E	64.25.D.F	64.20.E.B	3.43
32	64.25.E	64.32.D.F	64.25.E.B	4.25
40	64.32.E	64.40.D.F	64.32.E.B	4.41
50	64.40.E	64.50.D.F	64.40.E.B	5.12
63	64.50.E	64.63.D.F	64.50.E.B	5.75
80	64.63.E	64.80.D.F	64.63.E.B	6.54
100	64.80.E	64.100.D.F	64.80.E.B	7.48
125	64.100.E	on request	64.100.E.B	8.46
160	64.125.E	on request	on request	9.65
200	on request	on request	on request	on request
250	on request	on request	on request	on request

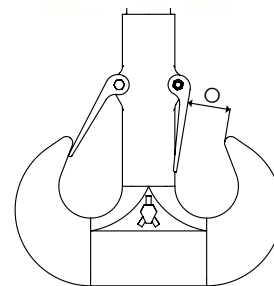

Ropeblock latches are zinc plated and are also available in stainless steel.

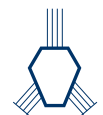

ROPEBLOCK

BUOYS

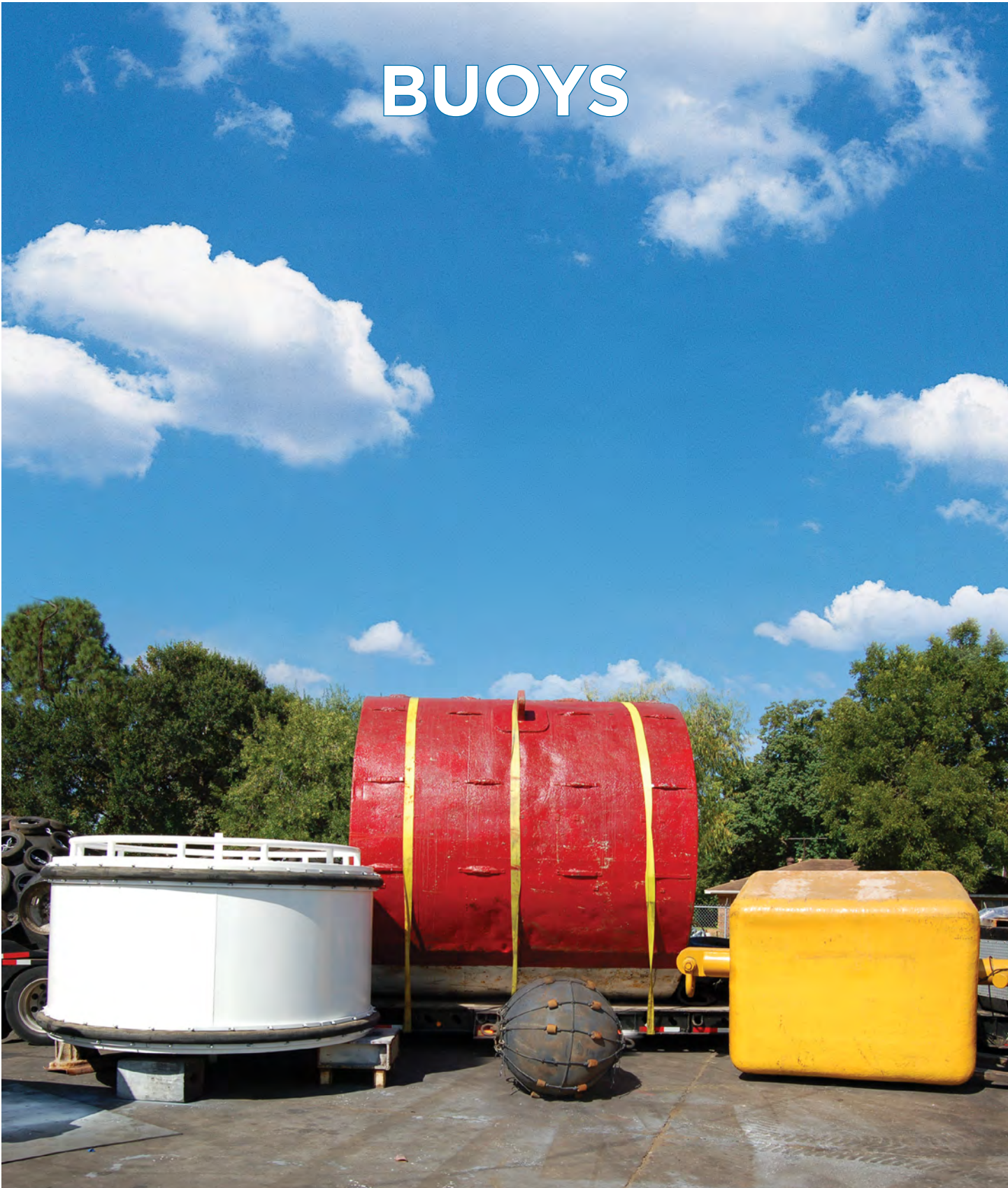

SPHERICAL TYPE BUOY



	30"	40"	58"
Buoyancy	416 lbs.	987 lbs.	3,007 lbs.
Dry Weight	198 lbs.	312 lbs.	694 lbs.
Total Liquid Capacity	58 gal	140 gal	440 gal

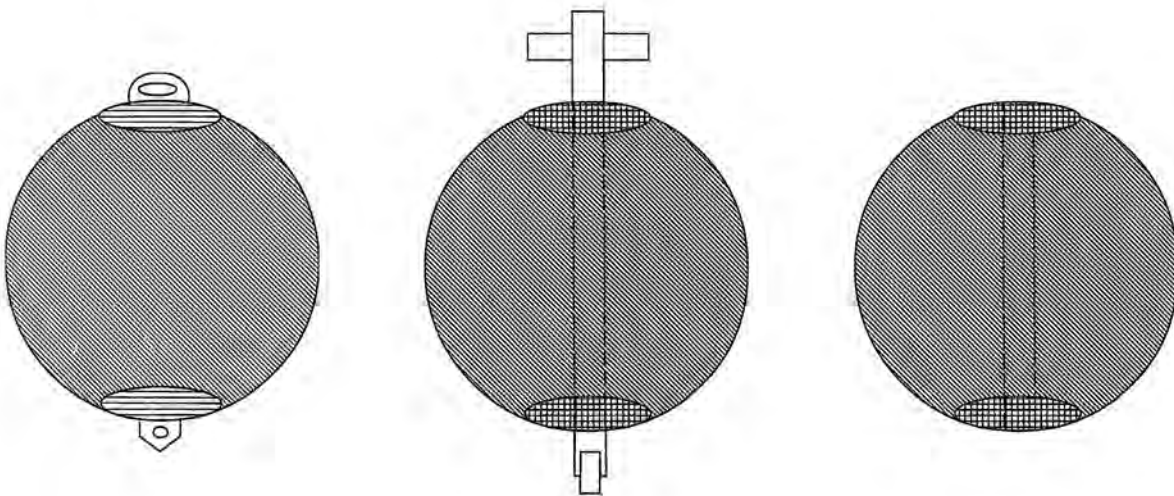

30" SPHERICAL BUOY PAD EYES EACH END

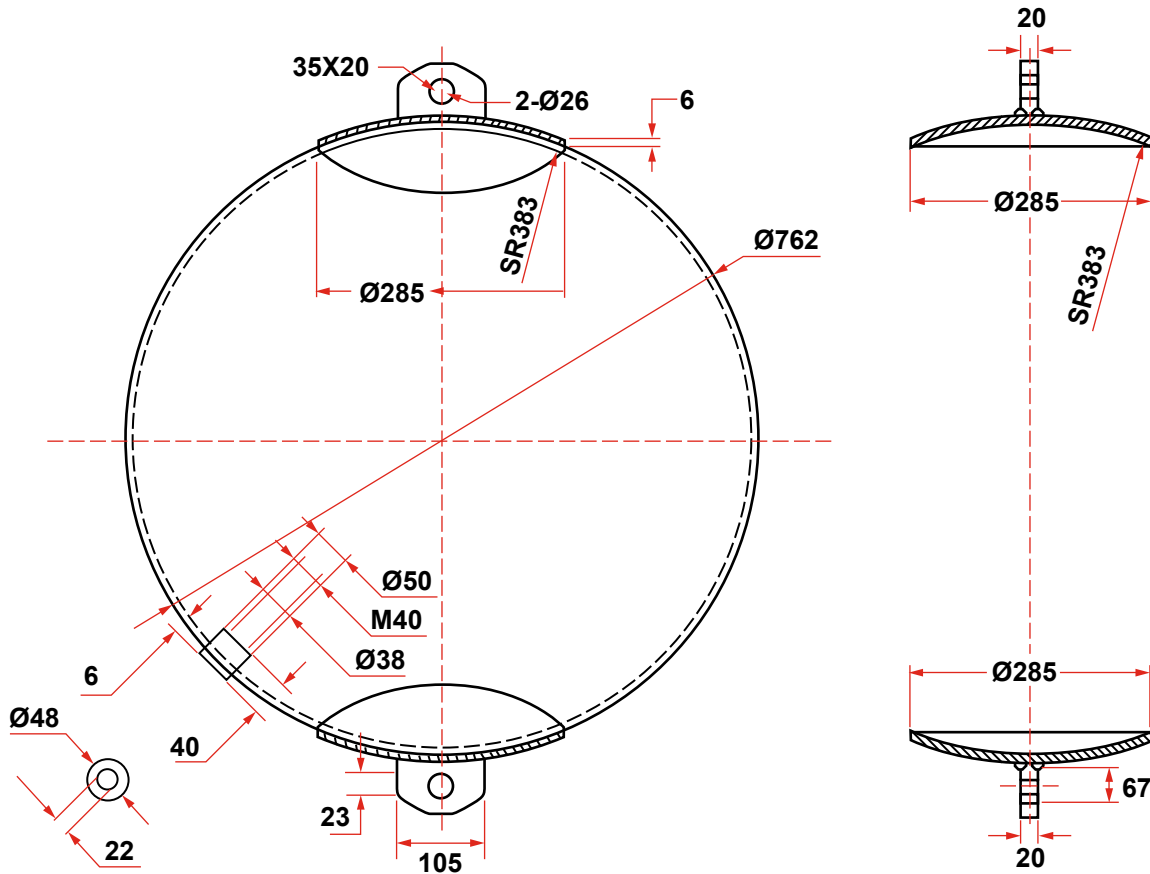

BUOYANCY: 416 LBS.
WEIGHT: 198 LBS.
CAPACITY: 58 GAL

40" SPHERICAL BUOY PAD EYES EACH END

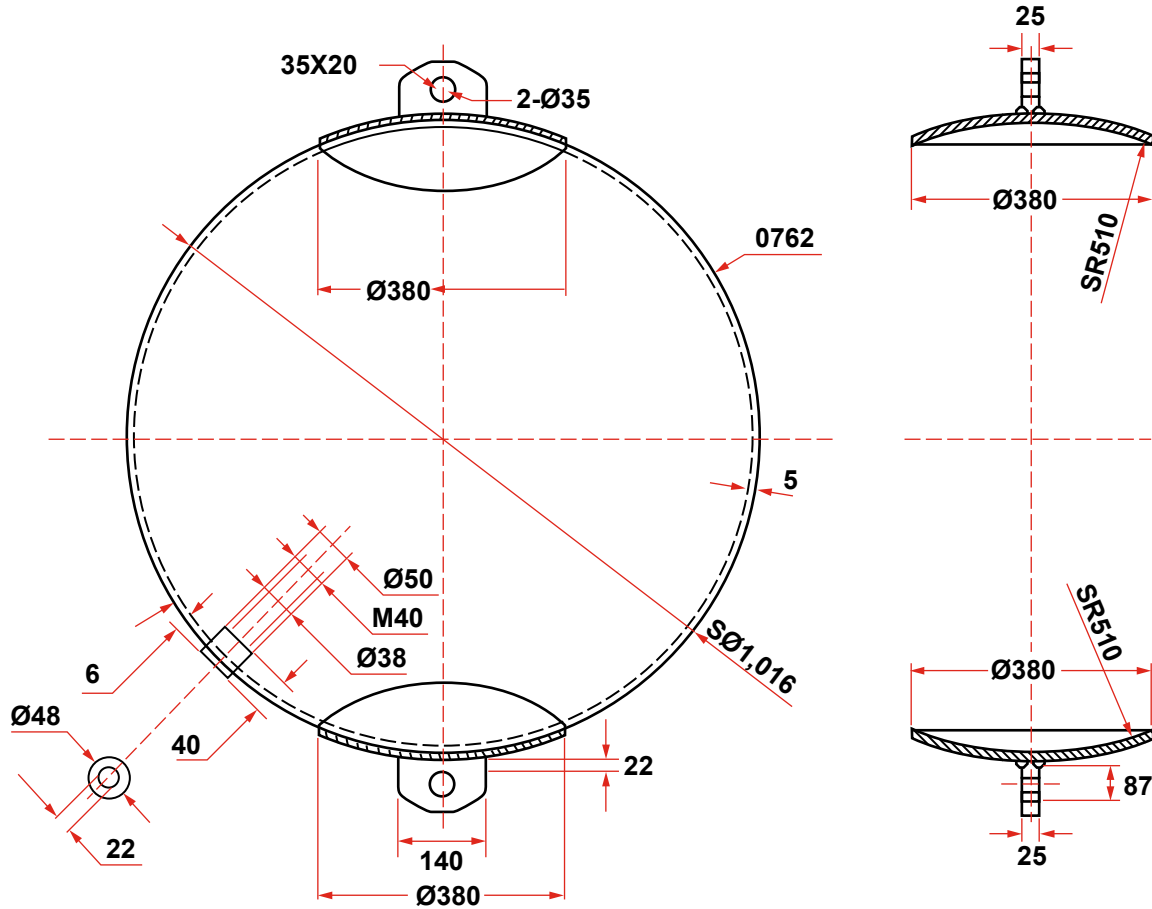

**BUOYANCY: 987 LBS.
WEIGHT: 312 LBS.
CAPACITY: 140 GAL**

58" SPHERICAL BUOY WITH PIPE THROUGH

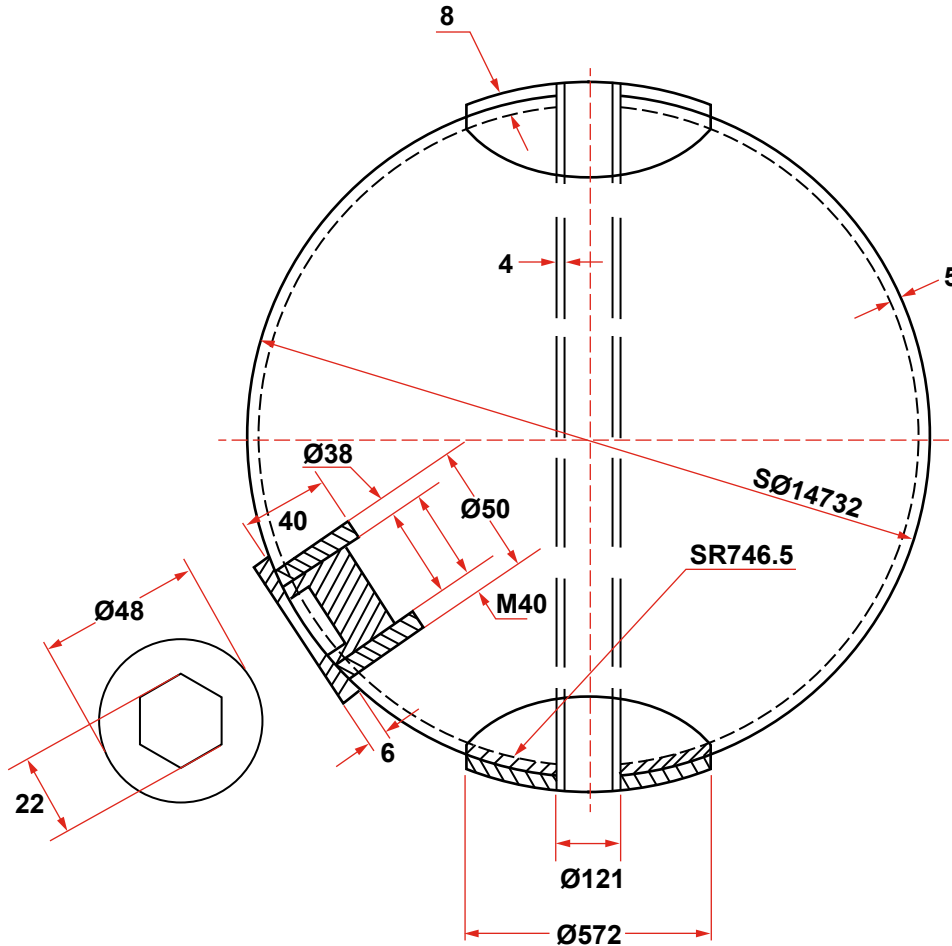

BUOYANCY: 3007 LBS.
WEIGHT: 694 LBS.
CAPACITY: 420 GAL

OCEAN GUARD™ RESILIENT FOAM FILLED BUOYS

The Ocean Guard™ Buoy's resilient surfaces are constructed to withstand the toughest marine applications and environments the world can offer. Ocean Guard™ Buoys are constructed with the latest technology and materials and exemplify state-of-the-art technology in buoy design and functionality. Composite buoys are designed to absorb minor impacts without damaging the buoy body or vessel.

PERFORMANCE FEATURES

UNSYNKABLE CONSTRUCTION

The Ocean Guard™ Buoy's closed cell foam filled construction provides a buoy that is unsinkable even if it's punctured.

IMPACT ABSORBING

The resilient outer foam layer and the reinforced elastomeric skin of the Ocean Guard™ Buoy are designed to absorb impacts of vessels without damaging the buoy or the impacting vessel.



NON MARKING

The tough, thick, reinforced elastomeric urethane skin of Ocean Guard™ Buoys is non marking, available in different colors and will not wear off.



END FITTINGS

Ocean Guard™ Buoys' end fittings are available in a variety of styles including mooring tees, padeyes, quick release hooks, swivel eyes, bails, forged eyes, hawse pipe with capture plates and navigational lights.



SUPERIOR TO STEEL BUOYS

Ocean Guard™ Buoys are designed and constructed to be lighter, more corrosion resistant, less maintenance and easier to handle than conventional steel buoys. The abrasion resistant urethane skin will resist the harshest environments without corroding.

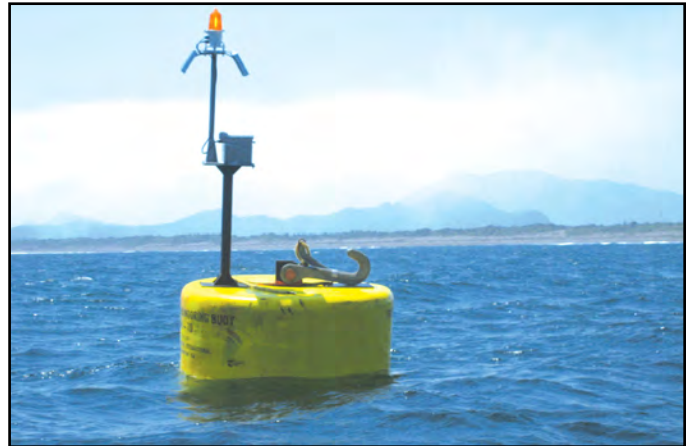

CUSTOM DESIGNS

Engineers work closely with the customer to select or custom design an Ocean Guard™ Buoy to meet their specific requirements.

CONSTRUCTION FEATURES

INTERNAL STEEL CENTRAL STRENGTH MEMBERS

The Ocean Guard™ Buoys' construction begins with an ultra heavy duty internal steel central strength member which provides excellent working load performance. The welded steel structure contains load distribution plates which provide outstanding pull-through performance.



RIGID INNER CLOSED CELL URETHANE FOAM CORE

The second layer in Ocean Guard™ Buoy construction consists of a US Coast Guard compliant rigid inner 100% closed cell urethane foam core. This strong foam core has excellent buoyancy and compression strength properties. The foam is molded directly onto the internal Steel Central Strength Member which provides an unsinkable buoy.

Ultra heavy duty central steel core load distribution construction

Impact absorbing, resilient heat laminated cross-linked polyethylene foam core foam

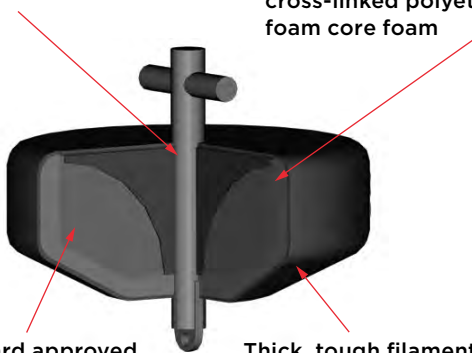

US Coast Guard approved inner closed cell rigid urethane buoyancy foam

Thick, tough filament nylon tire cord reinforced urethane skin



RESILIENT OUTER FOAM CORE

The third layer in Ocean Guard™ Buoy construction consists of an impact absorbing closed cell cross-linked polyethylene foam core. The same heat lamination process used in our Ocean Guard™ fenders produces a thermal bond between the layers of foam which is stronger than the foam itself. It will not delaminate even under the most abusive berthing conditions. This impact absorbing foam core is added to absorb vessel impacts without damaging the buoy or the impacting vessel.

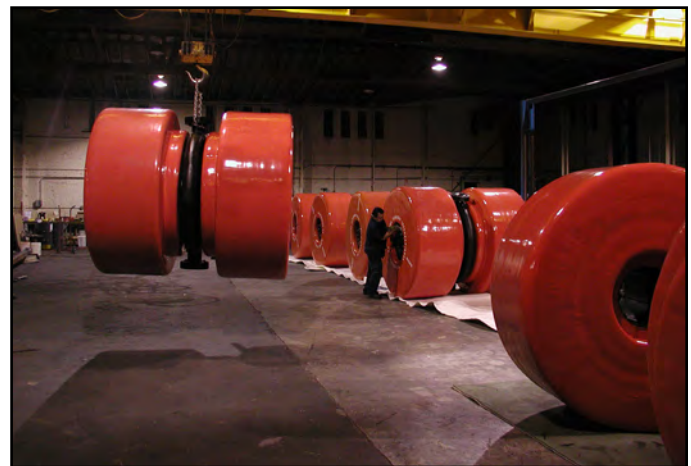

REINFORCED ELASTOMERIC SKIN

The final layer is a tough, thick filament nylon tire cord reinforced elastomer skin. This non-marking, reinforced elastomer fender skin is the wear surface of the fender. The reinforcing filaments are continuously wound in a helix pattern through up to 90% of the elastomer skin and wrap around the buoy's end fittings. This continuous reinforcement of the elastomer skin not only increases the tensile and tear strength of the elastomer, but also distributes loads throughout the fender skin.

This resilient material is specially formulated to withstand the world's harshest environmental conditions, providing superior performance in extreme temperatures, toxic environments, against hydrocarbons, salt water, ozone and ultraviolet radiation.

OCEAN GUARD MOORING BUOYS

BUOY MODEL	BUOYANCY NET		BUOY WEIGHT		DIAMETER OVERALL		HEIGHT BUOY BODY		HEIGHT OVERALL		WORKING LOAD	
	LBS	KG	LBS	KG	FT	M	FT	M	FT	M	LBS	TONS
MB-25	5,512	2,500	1,756	797	6.1	1.9	3.6	1.1	7.6	2.3	100,000	45
MB-35	7,716	3,500	2,340	1,061	7.0	2.1	4.3	1.3	8.5	2.6	150,000	68
MB-50	11,023	5,000	2,371	1,075	7.5	2.3	4.9	1.5	8.6	2.6	150,000	68
MB-70	15,432	7,000	2,938	1,333	8.5	2.6	5.0	1.5	8.6	2.6	200,000	91
MB-90	19,842	9,000	4,657	2,112	10	3.0	5	1.5	8.6	2.6	200,000	91
MB-115	25,353	11,500	5,109	2,317	10	3.0	6.1	1.9	9.5	2.9	200,000	91
MB-135	29,762	13,500	6,017	2,729	10.5	3.2	6.5	2.0	10.0	3.0	300,000	136
MB-160	35,274	16,000	6,333	2,873	11	3.4	6.8	2.1	11.75	3.6	300,000	136
MB-185	40,785	18,500	6,836	3,101	11.1	3.4	7.8	2.4	12.7	3.9	300,000	136
MB-225	49,604	22,500	8,491	3,852	12.0	3.7	8.1	2.5	12.9	3.9	300,000	136
MB-250	55,116	25,000	9,469	4,295	12.5	3.8	8.3	2.5	13.1	4.0	300,000	136
MB-275	60,627	27,500	9,965	4,520	12.6	3.8	8.9	2.7	13.7	4.2	300,000	136
MB-340	74,957	34,000	11,841	5,371	13.83	4.2	9	2.7	13.8	4.2	300,000	136
MB-455	100,310	45,500	14,599	6,622	15	4.6	10	3.0	14.8	4.5	300,000	136

* Actual values for above sizes may vary +/- 15% due to variations in materials and tolerances.



OCEAN GUARD SUPPORT BUOYS

BUOY MODEL	BUOYANCY NET		BUOY WEIGHT		DIAMETER OVERALL		HEIGHT OVERALL		WORKING LOAD	
	LBS	KG	LBS	KG	FT	M	FT	M	LBS	TONS
SB-25	551	250	158	72	2.6	0.8	2.6	0.8	22,000	10
SB-50	1,102	500	285	129	3.2	1.0	3.2	1.0	22,000	10
SB-75	1,653	750	390	177	3.5	1.1	3.5	1.1	22,000	10
SB-100	2,205	1,000	475	215	3.8	1.2	3.8	1.2	40,000	18
SB-125	2,756	1,250	537	244	4.1	1.2	4.1	1.2	40,000	18
SB-150	3,307	1,500	584	265	4.3	1.3	4.3	1.3	40,000	18
SB-175	3,858	1,750	687	312	4.6	1.4	4.6	1.4	40,000	18
SB-200	4,409	2,000	819	371	4.8	1.5	4.8	1.5	40,000	18
SB-250	5,511	2,500	931	422	5.2	1.6	5.2	1.6	40,000	18
SB-300	6,614	3,000	1,200	544	5.5	1.7	5.5	1.7	45,000	20
SB-350	7,716	3,500	1,300	590	5.8	1.8	5.8	1.8	45,000	20
SB-400	8,818	4,000	1,612	731	6.0	1.8	6.0	1.8	45,000	20
SB-450	9,921	4,500	1,712	777	6.2	1.9	6.2	1.9	45,000	20
SB-500	11,023	5,000	1,945	882	6.4	2.0	6.4	2.0	45,000	20
SB-600	13,228	6,000	2,302	1,044	6.8	2.1	6.8	2.1	45,000	20
SB-700	15,432	7,000	2,500	1,134	7.2	2.2	7.2	2.2	45,000	20

* Actual values for above sizes may vary +/- 15% due to variations in materials and tolerances.



OCEAN GUARD UTILITY CYLINDRICAL BUOYS

BUOY MODEL	BUOYANCY NET		BUOY WEIGHT		DIAMETER OVERALL		BUOY HEIGHT		HEIGHT OVERALL		WORKING LOAD	
	LBS	KG	LBS	KG	FT	M	FT	M	FT	M	LBS	TONS
CB-5	110	50	55	25	1.3	0.4	2	0.6	2.8	0.9	5,000	2.3
CB-10	220	100	79	36	1.5	0.5	2.8	0.8	3.6	1.1	5,000	2.3
CB-15	331	150	93	42	1.7	0.5	3.0	0.9	3.8	1.2	5,000	2.3
CB-25	551	250	160	73	2.2	0.7	3.1	0.9	4.0	1.2	7,500	3.4
CB-45	992	450	222	101	2.5	0.8	4.0	1.2	5.1	1.5	10,000	4.5
CB-70	1,543	700	340	154	3.0	0.9	4.2	1.3	5.3	1.6	10,000	4.5
CB-100	2,205	1,000	439	199	3.3	1.0	5	1.5	6.33	1.9	20,000	9.1
CB-115	2,535	1,150	539	244	3.5	1.1	5.0	1.5	6.3	1.9	20,000	9.1
CB-140	3,086	1,400	606	275	3.5	1.1	6.0	1.8	7.3	2.2	20,000	9.1
CB-180	3,968	1,800	704	319	4.0	1.2	5.8	1.8	7.4	2.3	40,000	18.0
CB-230	5,071	2,300	868	394	4.5	1.4	5.9	1.8	7.5	2.3	40,000	18.0
CB-275	6,063	2,750	973	441	4.5	1.4	7.0	2.1	8.6	2.6	40,000	18.0

* Actual values for above sizes may vary +/- 15% due to variations in materials and tolerances.

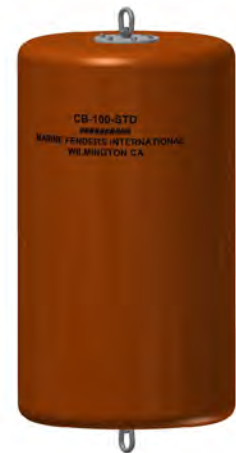

OCEAN GUARD PENDANT BUOYS



BUOY MODEL	BUOYANCY NET		BUOY WEIGHT		DIAMETER OVERALL		BUOY LENGTH		HEIGHT OVERALL		WORKING LOAD	
	LBS	KG	LBS	KG	FT	M	FT	M	FT	M	LBS	TONS
PB-25	5,511	2,500	1,223	555	4.5	1.4	6.8	2.1	7.3	2.2	150,000	68
PB-50	11,023	5,000	2,123	963	6.0	1.8	7.2	2.2	8.7	2.7	150,000	68
PB-75	16,534	7,500	3,184	1,444	6.5	2.0	9.2	2.8	9.2	2.8	150,000	68
PB-100	22,046	10,000	2,735	1,241	6.5	2.0	11.0	3.4	9.3	2.8	150,000	68
PB-150	33,069	15,000	4,020	1,823	8.0	2.4	11.5	3.5	10.9	3.3	150,000	68
PB-200	44,092	20,000	4,922	2,233	8.5	2.6	13.5	4.1	11.5	3.5	200,000	91
PB-250	55,115	25,000	5,827	2,643	9.0	2.7	15.0	4.6	11.8	3.6	200,000	91
PB-300	66,138	30,000	6,688	3,034	9.5	2.9	16.0	4.9	12.8	3.9	200,000	91
PB-350	77,160	35,000	10,581	4,800	10.3	3.1	16.8	5.1	14.5	4.4	250,000	114
PB-400	88,183	40,000	11,449	5,193	10.5	3.2	18.0	5.5	16.3	5.0	250,000	114

* Actual values for above sizes may vary +/- 15% due to variations in materials and tolerances.

OCEAN GUARD MODULAR ANCHOR PENDANT BUOYS



BUOY MODEL	BUOYANCY NET		NUMBER OF MODULES	DIAMETER OVERALL		THROUGH PIPE DIAMETER	
	LBS	KG		FT	M	IN	MM
MAPB2-4	8,818	4,000	2	6.6	2.0	6.0	152
MAPB4-8	17,637	8,000	4	6.6	2.0	6.0	152
MAPB2-8	17,637	8,000	2	7.5	2.3	6.0	152
MAPB4-16	35,273	16,000	4	7.5	2.3	6.0	152
MAPB2-11	24,250	11,000	2	9.8	3.0	8.0	203
MAPB4-22	48,501	22,000	4	9.8	3.0	8.0	203
MAPB2-17	37,478	17,000	2	10.5	3.2	10.0	254
MAPB4-34	74,956	34,000	4	10.5	3.2	10.0	254
MAPB2-23	50,705	23,000	2	10.5	3.2	10.0	254
MAPB4-46	101,411	46,000	4	10.5	3.2	10.0	254

* Actual values for above sizes may vary +/- 15% due to variations in materials and tolerances.

OCEAN GUARD OCEANOGRAPHIC BUOYS



BUOY MODEL	BUOYANCY NET		FLOTATION WEIGHT		TOTAL WEIGHT		DIAMETER OVERALL		DIAMETER INTERNAL		FLOTATION HEIGHT		TOWER HEIGHT	
	LBS	KG	LBS	KG	LBS	KG	FT	M	FT	M	FT	M	FT	M
OG-10	2,205	1,000	60	27	513	233	5.4	1.6	2.2	0.7	2.3	0.7	5.6	1.7
OG-15	3,307	1,500	72	33	606	275	6.1	1.9	2.3	0.7	2.4	0.7	5.6	1.7
OG-20	4,409	2,000	99	45	752	341	6.5	2.0	2.5	0.8	2.6	0.8	6.1	1.9
ATLAS-3	5,000	2,268	130	59	1,200	544	7.4	2.3	3.2	1.0	3.2	1.0	7.0	2.1

* Actual values for above sizes may vary +/- 15% due to variations in materials and tolerances.

OCEAN GUARD NAVIGATIONAL AND MARKER BUOYS

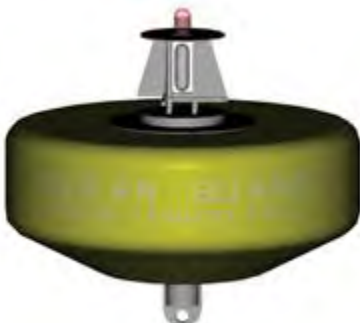

BUOY MODEL	BUOYANCY NET		BUOY WEIGHT		BUOY DIAMETER		BUOY BODY HEIGHT	
	LBS	KG	LBS	KG	FT	M	FT	M
NAV-100	221	100	194	88	3.0	0.9	2.3	0.7
NAV-200	441	200	399	181	3.8	1.2	3.0	0.9
NAV-500	1,103	500	650	295	4.9	1.5	3.0	0.9
NAV-750	1,654	750	981	445	6.7	2.0	3.3	1.0
NAV-1000	2,205	1,000	1,816	824	8.5	2.6	4.2	1.3
NAV-3000	6,615	3,000	3,112	1,412	10.0	3.0	4.5	1.4
NAV-5000	11,025	5,000	4,462	2,024	10.2	3.1	6.0	1.8
NAV-7500	16,538	7,500	6,703	3,040	11.8	3.6	6.6	2.0
NAV-10000	22,050	10,000	7,845	3,558	13.2	4.0	6.0	1.8

* Actual values for above sizes may vary +/- 15% due to variations in materials and tolerances.

OCEAN GUARD CHAIN THROUGH BUOYS



BUOY MODEL	NET BUOYANCY		BUOY WEIGHT		BODY DIAMETER		BODY LENGTH		OVERALL LENGTH		THROUGH PIPE DIAMETER	
	LB	KG	LB	KG	FT	M	FT	M	FT	M	IN	MM
CTB-100	2,205	1000	1,170	570	3.6	1.1	5.8	1.7	7.0	2.1	13.0	330
CTB-150	3,307	1,500	1,345	610	4.1	1.3	5.9	1.7	7.1	2.1	13.0	330
CTB-200	4,409	2,000	1,488	675	4.5	1.4	6.2	1.9	7.7	2.4	13.0	330
CTB-225	4,960	2,250	1,842	777	4.9	1.5	6.0	2.0	7.5	2.4	15.0	381
CTB-275	6,063	2,750	2,023	840	5.1	1.6	6.6	2.1	8.0	2.6	15.0	381
CTB-350	7,716	3,500	2,698	1,060	5.1	1.6	8.6	2.9	10.0	3.4	17.0	432
CTB-400	8,818	4,000	2,791	1,159	5.3	1.7	9.0	2.6	10.3	3.1	17.0	432
CTB-450	9,921	4,500	3,076	1,395	5.5	1.8	9.2	2.6	10.5	3.1	19.0	483
CTB-550	12,125	5,500	3,440	1,560	5.8	1.8	9.8	3.2	11.0	3.7	19.0	483

* Actual values for above sizes may vary +/- 15% due to variations in materials and tolerances.

OCEAN GUARD RECTANGULAR ANCHOR PENDANT BUOYS



BUOY MODEL	BUOYANCY NET		BUOY WEIGHT		BUOY DIMENSIONS								WORKING LOAD	
	LBS	KG	LBS	KG	LENGTH		HEIGHT		WIDTH		OVERALL HEIGHT		FT	TONS
RPB-10	2,200	1000	408	185	3.0	0.9	5.0	1.5	3.0	0.9	7.3	2.2	150,000	68
RPB-20	4,400	2000	817	371	3.6	1.1	5.0	1.5	5.0	1.5	7.3	2.2	150,000	68
RPB-40	8,800	4000	1,470	667	4.5	1.4	6.0	1.8	6.0	1.8	9.9	3.0	150,000	68
RPB-60	13,200	6000	3,060	1,388	5.0	1.5	7.0	2.1	8.5	2.6	10.9	3.3	150,000	68
RPB-80	17,600	8000	3,514	1,594	5.4	1.6	7.5	2.3	8.5	2.6	11.4	3.5	150,000	68
RPB-100	22,000	10000	4,312	1,956	6.0	1.8	9.0	2.7	8.1	2.5	12.6	3.8	150,000	68
RPB-120	26,400	12000	4,641	2,105	6.5	2.0	9.5	2.9	8.4	2.6	13.4	4.1	150,000	68
RPB-140	30,800	14000	5,835	2,647	6.5	2.0	10.5	3.2	9.0	2.7	14.8	4.5	200,000	91
RPB-160	35,200	16000	6,442	2,922	6.5	2.0	10.5	3.2	10.5	3.2	14.6	4.5	200,000	91
RPB-180	39,600	18000	7,195	3,264	6.5	2.0	11.5	3.5	11.0	3.4	15.6	4.8	200,000	91
RPB-200	44,000	20000	7,533	3,417	8.0	2.4	11.0	3.4	10.7	3.3	14.8	4.5	200,000	91
RPB-250	55,000	25000	8,427	3,822	8.5	2.6	12.6	3.8	10.8	3.3	16.5	5.0	200,000	91
RPB-300	66,000	30000	9,918	4,499	8.5	2.6	14.4	4.4	11.1	3.4	18.2	5.5	200,000	91

* Actual values for above sizes may vary +/- 15% due to variations in materials and tolerances.

OCEAN GUARD UNIVERSAL BUOYS

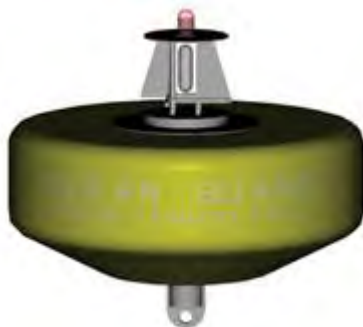

BUOY MODEL	NET BUOYANCY (MIN)		BUOY WEIGHT		BODY DIAMETER		BODY HEIGHT		OVERALL HEIGHT	
	LBS	KG	LBS	KG	FT	M	FT	M	FT	M
UB-1500	1,500	680	710	322	4.2	1.3	2.5	0.8	4.3	1.3
UB-2000	2,000	907	801	363	4.2	1.3	3.3	1.0	5.5	1.7
UB-2500	2,500	1,134	689	313	5.0	1.5	2.9	0.9	5.0	1.5
UB-3000	3,000	1,361	929	421	5.0	1.5	3.3	1.0	5.5	1.7
UB-4000	4,000	1,814	1,488	675	6.0	1.8	3.3	1.0	5.5	1.7
UB-5000	5,000	2,268	1,570	712	6.0	1.8	3.8	1.1	6.0	1.8

* Actual values for above sizes may vary +/- 15% due to variations in materials and tolerances.

UNIVERSAL BUOY END FITTINGS



Bail Eye



Pad Eye



Pick-Up Tee



Swivel Eye

PEG TOP BUOY

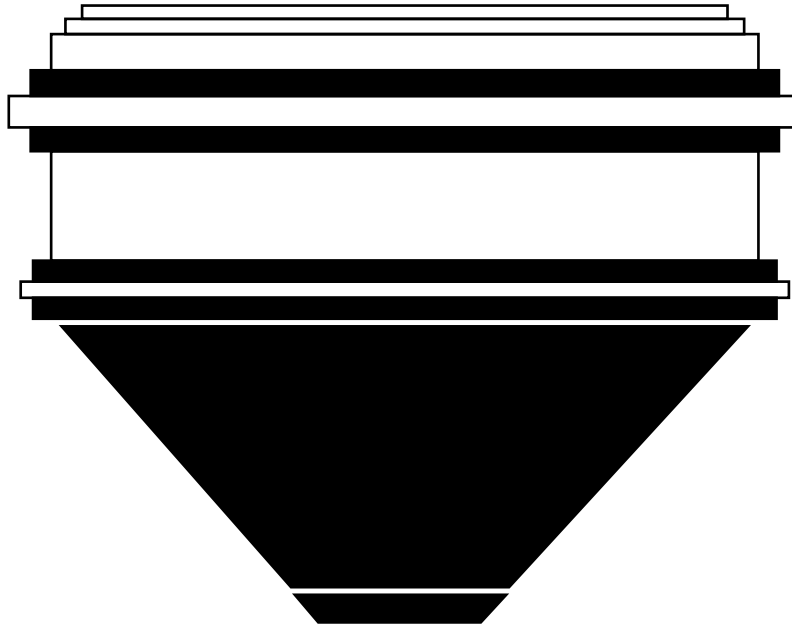







DIMENSIONS: 13'0" DIA. X 10'0" HIGH
DISPLACEMENT OF SEAWATER: 48,100 LBS.
TOTAL BUOYANCY: 35,300 LBS.
WEIGHT: 12,800 LBS.
ATTACHMENTS: RUBBER RUBBING STRIPS
TYPICAL MANWAYS

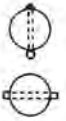

FLOATS - UTILITY AND BARRIER

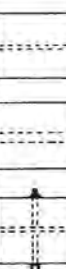
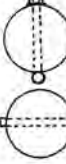
- Foam filled and ultraviolet inhibited. -- COLORS: Orange or White
- Yellow available on special order.
- Sturdy ABS hull. Models 1830 are one piece high density polyethylene.
- Reflective bands available.

Barrier Floats are attached in series to restrict boating traffic or swimmers from specific danger areas such as around dams and spillways or anywhere that hazardous conditions exist.

UTILITY FLOATS	FOR SWIM AREAS AND GENERAL	DIA. AND LENGTH	DESCRIPTION - STANDARD COLORS ARE INTENTIONAL ORANGE AND WHITE - PALIN SOLID COLOR (SPECIFY WHEN ORDERING)	SUB BUOYANCY	NET WT.
B1130-AW B1130-AO B1130-BW B1130-BO		12" Sphere	A - 3/8" Dia. galvanized steel rod thru float with steel reinforcing washers on both ends. Large 3" dia. attachment hoop. B - 1/2" Sch. 40 PVC pipe thru float. Anchored in foam to prevent movement.	30 lbs.	3 lbs.
BARRIER FLOATS	Combine with buoys in barrier systems				
B1218-AW B1218-AD B1218-BW B1218-BO		12" Dia. 18" Length	A - 1/2" Dia. galvanized steel rod thru float. Galvanized eye nut swivels on both ends. B - 1/2" Sch. 40 PVC pipe thru float. Anchored in foam to prevent movement.	55 lbs.	8 lbs.
B1830-AW B1830-AO B1830-BW B1830-BO B1830-CW B1830-CO		18" Dia. 30" Length	A - 5/8" Dia. steel rod thru float. Galvanized swivel eye nuts on both ends. B - 1" Sch. 40 galvanized steel pipe thru float. Anchored in foam to prevent movement. C - 5/8" Dia. steel rods thru float and also across dia. in center. Eye nut swivels on both ends of float and lower center rod. Extended rod at center-top for pick up eye.	200 lbs.	19 lbs. 19 lbs. 23 lbs.
B2436-AW B2436-AO B2436-BW B2436-BO B2436-CW B2436-CO		24" Dia. 36" Length	A - 3/4" Dia. steel rod thru float. Galvanized eye nuts swivels on both ends. B - 1" Sch. 40 galvanized steel pipe thru float. Anchored in foam to prevent movement. C - 3/4" Dia. steel rods thru float and also across dia. at center. Eye nut swivels on both ends of float and lower center rod. Extender rod at center-top for pick up eye.	400 lbs.	46 lbs. 46 lbs. 53 lbs.
B2400-AW B2400-AO B2400-BW B2400-BO		24" Dia.	A - 1/2" Dia. galvanized steel rod thru float. with steel reinforcing washers both ends. Large 3" dia. hoop. Completely foam filled. B - 1" dia. galvanized steel pipe thru float. Anchored in foam to prevent movement.	240 lbs.	23 lbs.
B509-RW B509-BW B139-3 B139-2	ROPE FLOATS  FLOAT CLIP  ROPE 	2-1/2" Dia. 5" Length 3/8" 3/8" Dia.	Plastic floats with 7/16" Dia. hole thru. Choice of red and white or blue and white. Use with rope floats. White polypropylene rope (use with rope floats). 600 Ft Reel		12 lbs. .01 lbs. 16 lbs.

NOTE: Last letter of Model number indicated color (W-White, O-Orange)

LARGE LIGHT-READY BUOYS AND CHANNEL MARKERS

FEATURES

- Easy reconditioning of weather-worn buoys with excellent adhesion of restoration materials.
- Excellent stability and visibility
- Tough ABS exteriors
- Completely urethane foam filled
- Ultraviolet inhibited
- Photo electric cell operated

Model B2460L* B2460LG	Model B1428NSWL		Model B2460L* B2460LG	Model B2460L* B2460LG
24"	14"	Can diameter	14"	14"
60"	30"	Can height	30"	30"
-	28"	Float collar diameter	28"	28"
116"	54"	Overall height	96"	54"
48"	42"	Exp. w/light & batgteries	37"	42"
59"	10"	Draft	51"	7"
780 lbs.	310 lbs.	Submerged buoyancy	310 lbs.	280 lbs.
240 lbs.	117 lbs.	Net Weight	135 lbs.	115 lbs.
330 lbs.	135 lbs.	Shippine weight	145 lbs.	135 lbs.

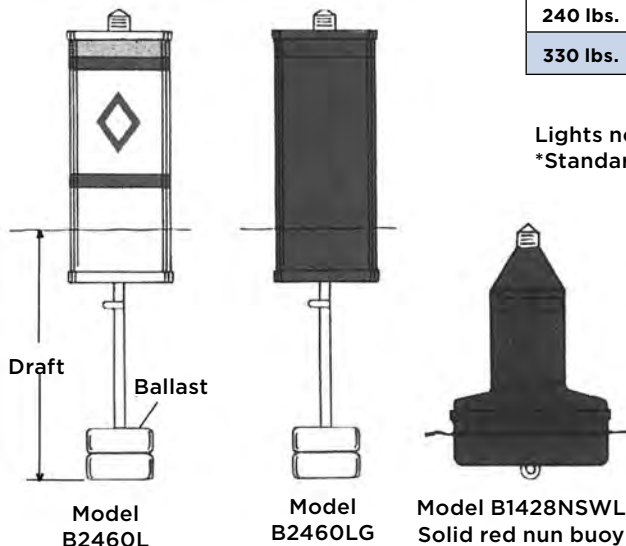

Lights not included. Order separately.
*Standard bands, symbols and messages included.

OPTIONS

- Internal radar reflectors
- Non-standard messages
- Agency and name identification
- Hi-intenisty bands and symbols
- Black and white or red and white centerline markers

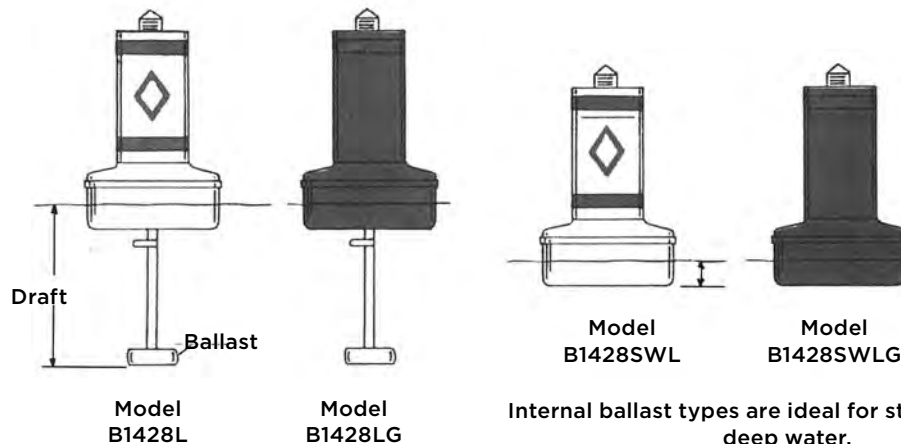

Internal ballast types are ideal for still, shallow and deep water.

REGULATORY BUOYS • ABS TYPE - 9" DIA.

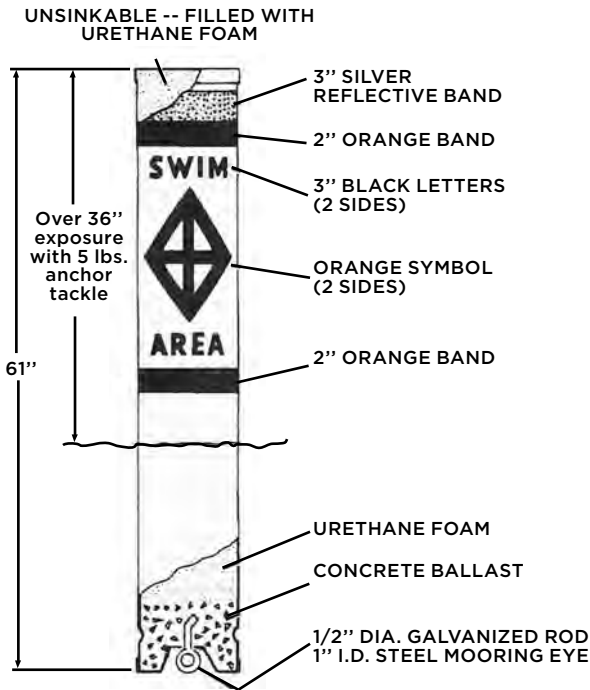

Approved and universally used by local, state and federal agencies to ensure water safety. Ideal for private applications.

MODEL B1147R

Includes choice of standard symbols and messages

FEATURES

- Easy reconditioning of weather-worn buoys with excellent adhesion of restoration materials.
- 9" diameter, white seamless, tough ABS plastic exterior.
- Will not rust, chip or peel. Ultraviolet inhibited.
- Completely urethane foam filled. Virtually unsinkable.
- 3" wide reflective band at top provides excellent night time visibility.
- Self-righting without tackle.
- Recessed cap allows buoy to stand upright.
- Heavy steel galvanized anchoring eye cast in an internal concrete ballast.
- Symbols and messages impregnated into buoy surface.

AVAILABLE OPTIONS

- Internal radar reflectors
- Pickup eye built into top
- Stainless steel anchoring eye for salt water applicators
- Agency or name identification
- Cone cap top
- Special non-standard messages
- 1/2" Pvc pipe thru for float line applications
- Lighted buoys

MODEL B1147R

Specify desired symbols and messages when ordering.

Submerged buoyancy 84 lbs.
Net weight 49 lbs.
Shipping weight 56 lbs.

STANDARD INLAND WATERWAY SYMBOLS AND MESSAGES	CONTROLLED AREA SYMBOL	HAZARD WARNING SYMBOL	RESTRICTED AREA SYMBOL	INFORMATION SYMBOL
	<p>SPECIAL MESSAGES ARE AVAILABLE.</p> <p>REQUEST A QUOTATION</p>	<p>2" BAND WIDTH</p>	<p>2" BAND WIDTH</p>	<p>2" BAND WIDTH</p>
	<p>STANDARD MESSAGES</p> <p>SLOW 5 MPH</p> <p>SLOW NO WAKE</p> <p>SKI AREA</p> <p>NO SKI</p> <p>SLOW 10 MPH</p> <p>SPEED ZONE</p> <p>NO WAKE IDLE</p> <p>SPEED</p>	<p>STANDARD MESSAGES</p> <p>ROCK</p> <p>DANGER</p> <p>RAPIDS</p> <p>SHOAL</p> <p>STUMP</p> <p>SHALLOW AREA</p> <p>HAZARD AREA</p> <p>DANGER DAM</p>	<p>STANDARD MESSAGES</p> <p>SWIM AREA</p> <p>KEEP OUT</p> <p>NO BOATS</p> <p>BOATS KEEP OUT</p> <p>CLOSED AREA</p> <p>NO BOATING</p> <p>DANGER DAM</p>	<p>STANDARD MESSAGES</p> <p>REST ROOM 1 MILE</p> <p>STATE PARK</p> <p>AHEAD</p> <p>MARINA</p> <p>ENTRANCE</p> <p>FISH ATTRACTOR</p>

SPAR BUOY • ABS TYPE - 5" DIA.

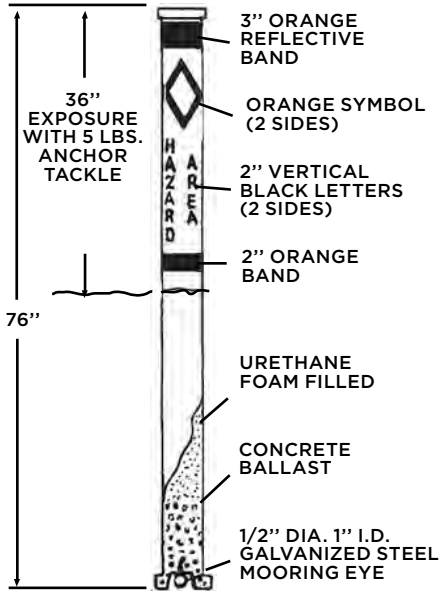

Lightweight, easy to handle - minimum anchor weight allows easy removal.

FEATURES

- Easy reconditioning of weather-worn buoys with excellent adhesion of restoration materials.
- 5" diameter, white, seamless, tough ABS plastic exterior. Ultraviolet inhibited, will not rust, chip or peel.
- Urethane foam filled. Virtually unsinkable.
- 3" wide reflective band at top provides excellent night visibility.
- Self-righting without tackle.
- Recessed cap allows buoy to stand upright.
- Heavy steel galvanized anchoring eye cast in an internal concrete ballast.
- In waterway making symbols with standard messages.

AVAILABLE OPTIONS:

- Internal radar reflectors
- Stainless steel anchoring eye for salt water applicators
- Special non-standard messages
- Agency or name identification

MODEL B576S

Standard symbols and messages included in price. Specify desired symbols and messages when ordering.

Submerged buoyancy 30 lbs.
Net weight 24 lbs.
Shipping weight 28 lbs.

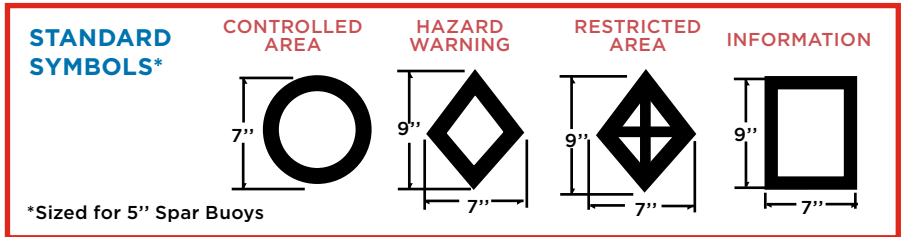

CAN BUOY • ABS TYPE -- 12" DIA. HANGING CAN BUOY SYSTEM

- Easy to recondition when necessary.
- Excellent adhesion of reconditioning materials.
- Excellent visibility.
- 12" diameter white ABS plastic exterior will not rust, chip or peel.
- Ultraviolet inhibited.
- Completely urethane foam filled.
- 2" orange reflective band at top and bottom provides excellent night time visibility.
- 3/8" galvanized attachment eyebolt.
- Choice of inland waterway marking symbols and standard messages. (2 sets).
- Special non-standard messages available.
- Cable and attaching hardware available.

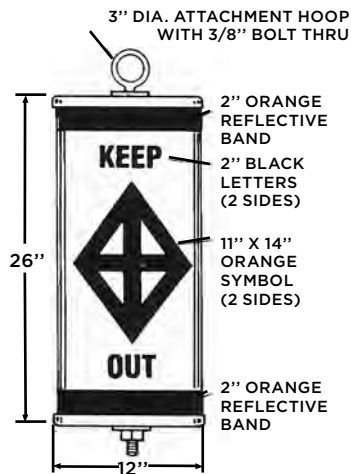

MODEL B1226

Net weight 12 lbs.
Shipping weight 18 lbs.

BUOYS ARE SUSPENDED FROM ABOVE
Excellent for short spans, swift water and areas with minimum public use.

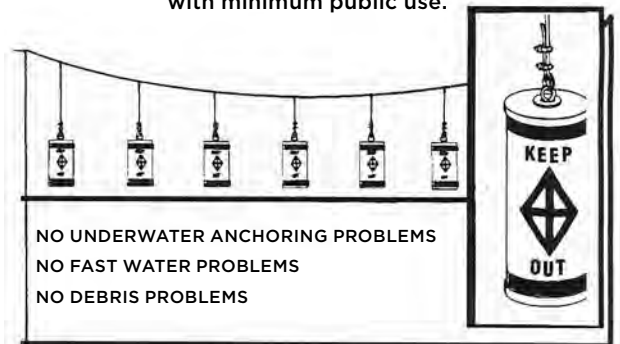

NOTE: The design and selection of a mooring system should be by a qualified professional engineer who is familiar with the specific application and local conditions. The illustrations shown are provided for informational purposes and are not intended to be suggested designs. Anchor assumes no responsibility for any mooring system based upon these illustrations.



A SERIES

THROUGHOUT THE WORLD, MORE PEOPLE RELY ON OUR A SERIES THAN ALL OTHER BUOYS.

The A Series is the product that launched the Polyform story. This all-purpose product, with the signature “blue ropehold,” has proven itself in the most adverse conditions. We’ve made a couple of changes to the legendary A-Series for 2001. There’s a new size – the A-7, with more buoyancy than any other buoy in its class, and a redesigned ropehold. The new ropehold has been incorporated into the A-5, A-6, and A-7 and features stronger ribs, a larger eye that accepts a standard shackle, and a new “dual valve” inflation-deflation system. Marking gear in heavy seas is no easy task. That’s why more fishermen use Polyform A Series than all other buoys combined. We’ve seen and heard the testimonials from our customers. You name the ocean, sea, or river, and the A Series has been there. Put your trust in Polyform’s most versatile and well-known product.

Model	Size (In) (Dia x Length)	Eye Dia. (in)	Circum. (in)	Volume (Gallons)	Pieces Per Carton
A-0	8 x 11.5	0.6	25.1	1.6	20
A-1	11 x 15	1	34.6	3.5	10
A-2	14.5 x 19.5	1.125	45.6	8.2	10
A-3	17 x 23	1.125	53.4	14.5	10
A-4	20.5 x 27	1.125	64.4	22.5	10
A-5	27 x 36	1.25	84.9	47.6	5
A-6	34 x 44	1.5	106.9	95.1	3
A-7	39 x 54	2	122.6	162	2

F SERIES

CLASSIC EUROPEAN TWIN-EYE STYLE FENDERS DESIGNED FOR THE MOST DEMANDING USE.

Polyform has been producing this fender for over 40 years and there is no comparison when it comes to quality, range of sizes and protection offered. The F Series fender has offered protection to the finest yachts and fishing vessels all over the world. Why?

Because the owners and the captains of these prestigious boats know that they can rely on Polyform’s F Series to offer the size, strength and dependability to protect their vessel from the rigors of the sea and weather. If you want the ultimate in protection for your boat, Polyform F Series is the only choice!

Model	Size (In) (Dia x Length)	Eye Dia. (in)	Circum. (in)	Volume (Gallons)	Pieces Per Carton
F-1	6 x 24	0.7	18.9	1.9	10
F-02	7.5 x 26	0.7	23.6	3.1	10
F-2	8.2 x 25	0.9	25.8	4.3	10
F-3	8.2 x 30	0.9	25.8	5.4	10
F-4	8.5 x 40.5	0.9	26.7	7.7	5
F-5	11 x 30	1	34.6	7.3	5
F-6	11 x 42	1	34.6	15.1	5
F-7	15 x 41	1	47.1	18.8	5
F-8	15 x 58	1	47.1	39.6	4
F-10	18 x 50	1	56.6	33.8	2
F-11	21.2 x 57.5	1.1	66.6	63.7	3
F-13	29 x 76.5	1.2	91.1	158.6	2

CHAIN

GENERAL INFORMATION

**ONE OF THE
LARGEST
INVENTORIES IN
THE COUNTRY**

**NEW & USED
CHAIN**

Always in Stock

RENTAL AVAILABLE

From 1/4" to 5-1/4" Diameter in the
West Coast
East Coast
and the Gulf Coast

We are DIRECT IMPORTERS and
FACTORY DISTRIBUTORS.

- WELDLESS CHAIN
- PROOF COIL CHAIN
- HIGH TEST
- LASHING
- COAST GUARD BUOY CHAIN
- STAINLESS STEEL
- ALLOY
- DOCK FENDER CHAIN
- STUD LINK
- U.S. NAVY
- CAST STEEL
- O.R.Q
- GRADES 2, 3, 4 AND 5

**DOMESTIC &
IMPORTED**

WITH or WITHOUT
CERTIFICATES
(A.B.S., LLOYDS, D.N.V., ETC.)

GIVE US A CALL
310.522.9698



GENERAL INFORMATION

DIMENSION RATIOS

For many years, dimensions of stud link anchor chain have been standardized so that all chain manufacturers are required to furnish chain conforming to dimension charts published by various testing societies (Lloyds, American Bureau of Shipping, etc.), within their limiting tolerances. For estimating purposes it is often useful to note the following:

The inside length ("grip" or pitch) of one link is 4 wire diameters.

The outside length of one link is 6 wire-diameters.

The outside width of one link is 3.56 wire-diameters.

The gauge-test length is the outside length over 6 links and equals 26 wire-diameters.

The weight of one link is about 3-1/3 times its wire diameter cubed.

Doubling the wire-diameter of one link multiplies its weight by 8.

The weight of 1 linear foot of chain is 10 times its wire-diameter squared.

The length of a standard "shot" = 15 fathoms = 90 ft. = 1080".

The weight of a 90 ft. shot = 900 times its wire-diameter squared.

Doubling the wire-diameter of a 90 ft. shot multiplies its weight by 4.

Doubling the size of a chain theoretically multiplies its strength by 4; in practice, by a trifle less than 4.

The safe working load of chain is ordinarily assumed as one half the proof test.

CHAIN LENGTHS REQUIRED

In determining amount of anchor chain to be used for a particular anchorage it is usual to allow 5 to 7 times the depth of water; dependent on such factors as nature of bottom, present and anticipated weather, tidal and current conditions, state of readiness of the ship's powerplant, draft, amount of exposed hull and superstructure, and length of stay at anchor. (U.S. Coast Guard)

CHAIN AND LINK MAINTENANCE

Anchor chain cable should be ranged at regular intervals and examined for damage and signs of excessive wear. It is considered good practice to occasionally shift the shots about in the chain to insure even wear. The chains may also be sprayed with a preservative such as fish oil at this time. (U.S. Coast Guard)

The U.S. Navy instructs that at least once every eighteen (18) months all anchor chain cable regardless of size, including detachable links, swivels and shackles should be examined, over-hauled and placed in a good state of preservation. Chain connecting links particularly should be disassembled and the interiors recoated with grease, and identification mark restored if necessary.

GENERAL INFORMATION

DEFINITIONS

RATED LOAD VALUE	The maximum recommended load that should be exerted on the item. The following terms are also used for the term Rated Load: "SWL", "Safe Working Load", "Working Load", "Working Load Limit", and the "Resultant Safe Working Load." All rated load values, unless noted otherwise, are for in-line pull with respect to the centerline of the item.
PROOF LOAD	The average load to which an item may be subjected before visual deformation occurs or a load that is applied in the performance of a proof test.
PROOF TEST	A term designating a tensile test applied to the item for the sole purpose of detecting injurious defects in the material or manufacture.
ULTIMATE LOAD	The average load at which the item being tested fails or no longer supports the load.
SHOCK LOAD	A resulting load from the rapid change of movement, such as impacting or jerking, of a static load. A Shock Load is generally significantly greater than the static load.
SAFETY FACTOR	An industry term denoting theoretical reserve capability. Usually computed by dividing the catalog stated ultimate load by the catalog stated working load limit and generally expressed as a ratio, for example 5 to 1.
COMMERCIAL SURFACE QUALITY	The surface condition associated with the normal methods of production of raw material and machined surfaces. The surface condition of the products shown in this catalog. More refined surface qualities are considered as special.

All ratings given in tons refer to short tons of 2,000 lbs.

NOTE: The right is reserved to make changes in product design, material and specifications without incurring obligations.

WARNING:

Low and high carbon steel welded and weldless chain and attachments are not to be used for overhead lifting purposes or where its failure is likely to cause damage to property or persons.

STUD LINK ANCHOR CHAIN (IMPERIAL)

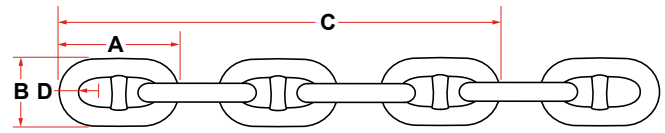

CHAIN NOMINAL DIAMETER	LINK LENGTH (A)	LINK WIDTH (B)	LENGTH OF 5 LINKS (C)	GRIP RADIUS (D)	APPROX LINKS PER SHOT	WEIGHT PER SHOT	GRADE 2		GRADE 3	
							PROOF LOAD	BREAKING LOAD	PROOF LOAD	BREAKING LOAD
In	In	In	In	In	Ea	Lbs	Lbf	Lbf	Lbf	Lbf
1/2	3	1 13/16	11	0.33	535	230	15300	21400	21400	30600
9/16	3 3/8	2	12 3/8	0.37	478	290	19300	27000	27000	38600
5/8	3 3/4	2 1/4	13 3/4	0.41	432	370	23700	33200	33200	47500
11/16	4 1/8	2 1/2	15 1/8	0.45	391	410	28600	40100	40100	57300
3/4	4 1/2	2 11/16	16 1/2	0.49	357	480	34000	47600	47600	68000
13/16	4 7/8	2 15/16	17 7/8	0.53	329	570	39800	55700	55700	79500
7/8	5 1/4	3 1/8	19 1/4	0.57	305	660	46000	64400	64400	91800
15/16	5 5/8	3 3/8	20 5/8	0.61	285	760	52600	73700	73700	105000
1	6	3 5/8	22	0.65	267	860	59700	86300	83600	119500
1 1/16	6 3/8	3 13/16	23 3/8	0.69	251	970	67200	94100	94100	135000
1 1/8	6 3/4	4 1/16	24 3/4	0.73	237	1080	75000	105000	105000	150000
1 3/16	7 1/8	4 1/4	26 1/8	0.77	225	1220	83400	116500	116500	167000
1 1/4	7 1/2	4 1/2	27 1/2	0.81	213	1350	92200	129000	129000	184000
1 5/16	7 7/8	4 3/4	28 7/8	0.85	203	1490	101500	142000	142000	203000
1 3/8	8 1/4	4 15/16	30 1/4	0.89	195	1630	111000	155000	155000	222000
1 7/16	8 5/8	5 3/16	31 5/8	0.93	187	1780	120500	169000	169000	241000
1 1/2	9	5 3/8	33	0.98	179	1940	131000	183500	183500	262000
1 9/16	9 3/8	5 5/8	34 3/8	1.02	171	2090	142000	198500	198500	284000
1 5/8	9 3/4	5 7/8	35 3/4	1.06	165	2240	153000	214000	214000	306000
1 11/16	10 1/8	6 1/16	37 1/8	1.10	159	2410	166500	229000	229000	327000
1 3/4	10 1/2	6 5/16	38 1/2	1.14	153	2590	176000	247000	247000	352000
1 13/16	10 7/8	6 1/2	39 7/8	1.18	147	2790	188500	264000	264000	377000
1 7/8	11 1/4	6 3/4	41 1/4	1.22	143	2980	201000	281000	281000	402000
1 15/16	11 5/8	7	42 5/8	1.26	139	3180	214000	299000	299000	427000
2	12	7 3/16	44	1.30	133	3360	227000	318000	318000	454000
2 1/16	12 3/8	7 7/16	45 3/8	1.34	129	3570	241000	337000	337000	482000
2 1/8	12 3/4	7 5/8	46 3/4	1.38	125	3790	255000	357000	357000	510000
2 3/16	13 1/8	7 7/8	48 1/8	1.42	123	4020	269000	377000	377000	538000
2 1/4	13 1/2	8 1/8	49 1/2	1.46	119	4250	284000	396000	396000	570000
2 5/16	13 7/8	8 5/16	50 7/8	1.50	117	4490	299000	418000	418000	598000
2 3/8	14 1/4	8 9/16	52 1/4	1.54	113	4730	314000	440000	440000	628000
2 7/16	14 5/8	8 3/4	53 5/8	1.58	111	4960	330000	462000	462000	660000
2 1/2	15	9	55	1.63	107	5270	346000	484000	484000	692000
2 9/16	15 3/8	9 1/4	56 3/8	1.67	105	5540	363000	507000	507000	726000
2 5/8	15 3/4	9 7/16	57 3/4	1.71	103	5820	379000	530000	530000	758000

STUD LINK ANCHOR CHAIN (IMPERIAL)

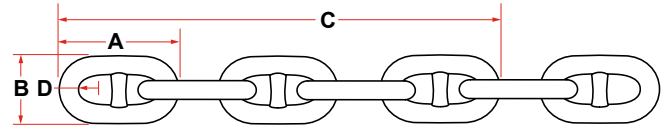

CHAIN NOMINAL DIAMETER	LINK LENGTH (A)	LINK WIDTH (B)	LENGTH OF 5 LINKS (C)	GRIP RADIUS (D)	APPROX LINKS PER SHOT	WEIGHT PER SHOT	GRADE 2		GRADE 3	
							PROOF LOAD	BREAKING LOAD	PROOF LOAD	BREAKING LOAD
In	In	In	In	In	Ea	Lbs	Lbf	Lbf	Lbf	Lbf
2 11/16	16 1/8	9 11/16	59 1/8	1.75	99	6110	396000	554000	554000	792000
2 3/4	16 1/2	9 7/8	60 1/2	1.79	97	6410	413000	578000	578000	826000
2 13/16	16 7/8	10 1/8	61 7/8	1.83	95	6710	431000	603000	603000	861000
2 7/8	17 1/4	10 3/8	63 1/4	1.87	93	7020	449000	628000	628000	897000
2 15/16	17 5/8	10 9/16	64 5/8	1.91	91	7330	467000	654000	654000	934000
3	18	10 13/16	66	1.95	89	7650	485000	679000	679000	970000
3 1/16	18 3/8	11	67 3/8	1.99	87	7980	504000	705000	705000	1008000
3 1/8	18 3/4	11 1/4	68 3/4	2.03	85	8320	523000	732000	732000	1046000
3 3/16	19 1/8	11 1/2	70 1/8	2.07	85	8660	542000	759000	759000	1084000
3 1/4	19 1/2	11 11/16	71 1/2	2.11	83	9010	562000	787000	787000	1124000
3 5/16	19 7/8	11 15/16	72 7/8	2.15	81	9360	582000	814000	814000	1163000
3 3/8	20 1/4	12 1/8	74 1/4	2.19	79	9730	602000	843000	843000	1204000
3 7/16	20 5/8	12 3/8	75 5/8	2.23	77	10100	622000	871000	871000	1244000
3 1/2	21	12 5/8	77	2.28	77	10500	643000	900000	900000	1285000
3 9/16	21 3/8	12 13/16	78 3/8	2.32	75	10900	664000	929000	929000	1327000
3 5/8	21 3/4	13 1/16	79 3/4	2.36	73	11300	685000	958000	958000	1369000
3 3/4	22 1/2	13 1/2	82 1/2	2.44	71	12000	728000	1019000	1019000	1455000
3 7/8	23 1/4	13 15/16	85 1/4	2.52	69	12900	772000	1080000	1080000	1543000
3 15/16	23 5/8	14 3/16	86 5/8	2.56	68	13300	794000	1111000	1111000	1587000
4	24	14 3/8	88	2.60	67	13700	816000	1143000	1143000	1632000
4 1/8	24 3/4	14 7/8	90 3/4	2.68	65	14600	862000	1207000	1207000	1724000
4 1/4	25 1/2	15 5/16	93 1/2	2.76	63	15400	908000	1272000	1272000	1817000
4 3/8	26 1/4	15 3/4	96 1/4	2.84	61	16200	956000	1338000	1338000	1911000
4 1/2	27	16 3/16	99	2.93	59	17100	1004000	1405000	1405000	2008000
4 5/8	27 3/4	16 5/8	101 3/4	3.01	57	18000	1053000	1474000	1474000	2105000
4 3/4	28 1/2	17 1/8	104 1/2	3.09	57	18900	1102000	1543000	1543000	2204000
4 7/8	29 1/4	17 9/16	107 1/4	3.17	55	19900	1153000	1613000	1613000	2305000
5	30	18	110	3.25	53	20900	1203000	1685000	1685000	2407000
5 1/8	30 3/4	18 7/16	112 3/4	3.33	52	22000	1255000	1757000	1757000	2509000
5 3/8	32 1/4	19 3/8	118 1/4	3.49	49	24000	1359000	1903000	1903000	2718000
5 5/8	33 3/4	20 1/4	123 3/4	3.66	47	26100	1466000	2052000	2052000	2932000
5 3/4	34 1/2	20 11/16	126 1/2	3.74	46	27000	1520000	2128000	2128000	3039000
6	36	21 5/8	132	3.90	45	29100	1629000	2280000	2280000	3257000
6 1/8	36 3/4	22 1/16	134 3/4	3.98	44	30200	1684000	2357000	2357000	3367000
6 3/8	38 1/4	22 15/16	140 1/4	4.14	42	32400	1795000	2512000	2512000	3589000

STUD LINK ANCHOR CHAIN (METRIC)

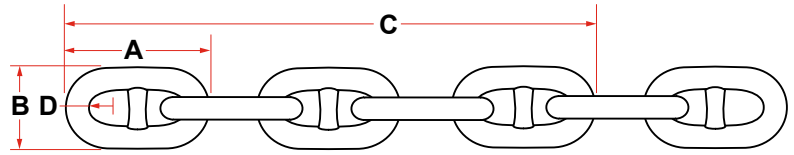

CHAIN NOMINAL DIAMETER	LINK LENGTH (A)	LINK WIDTH (B)	LENGTH OF 5 LINKS (C)	GRIP RADIUS (D)	LINKS PER SHOT	WEIGHT PER SHOT	GRADE 2		GRADE 3	
							PROOF LOAD	BREAKING LOAD	PROOF LOAD	BREAKING LOAD
mm	mm	mm	mm	mm	ea	kg	kN	kN	kN	kN
12.5	75	45	275	8.13	547	110	65.7	92.2	92.2	132.4
14	84	50	308	9.10	487	130	82.4	115.7	115.7	164.8
16	96	58	352	10.40	425	170	106.9	150.0	150.0	215.7
17.5	105	63	385	11.38	389	180	127.5	179.5	179.5	260.8
19	114	68	418	12.35	361	220	150.9	210.8	210.8	301.1
20.5	123	74	451	13.33	333	260	174.6	244.2	244.2	349.1
22	132	79	484	14.30	309	300	200.1	280.5	280.5	401.1
24	144	86	528	15.60	283	340	237.3	332.4	332.4	475.6
26	156	94	572	16.90	263	420	277.5	389.3	389.3	556.0
28	168	101	616	18.20	243	480	320.7	449.1	449.1	642.3
30	180	108	660	19.50	225	550	367.7	513.9	513.9	734.5
32	192	115	704	20.80	211	610	416.8	582.5	582.5	832.6
34	204	122	748	22.10	199	700	467.8	655.1	655.1	936.5
36	216	130	792	23.40	187	790	522.7	731.6	731.6	1049.3
38	228	137	836	24.70	177	880	580.6	812.0	812.0	1157.2
40	240	144	880	26.00	169	970	640.4	896.3	896.3	1284.7
42	252	151	924	27.30	161	1070	703.1	980.7	980.7	1402.3
44	264	158	968	28.60	155	1170	768.8	1078.7	1078.7	1539.6
46	276	166	1012	29.90	147	1270	836.5	1167.0	1167.0	1676.9
48	288	173	1056	31.20	141	1380	908.1	1274.9	1274.9	1814.2
50	300	180	1100	32.50	135	1480	980.7	1372.9	1372.9	1961.3
52	312	187	1144	33.80	131	1600	1059.1	1480.8	1480.8	2108.4
54	324	194	1188	35.10	125	1720	1137.6	1588.7	1588.7	2265.3
56	336	202	1232	36.40	121	1850	1216.0	1706.4	1706.4	2432.0
58	348	209	1276	37.70	117	1990	1294.5	1814.2	1814.2	2598.8
60	360	216	1320	39.00	113	2120	1382.7	1941.7	1941.7	2765.5
62	372	223	1364	40.30	109	2250	1471.0	2059.4	2059.4	2942.0
64	384	230	1408	41.60	107	2440	1559.3	2186.9	2186.9	3128.3
66	396	238	1452	42.90	103	2590	1657.3	2314.4	2314.4	3304.8
68	408	245	1496	44.20	99	2750	1745.6	2451.7	2451.7	3501.0
70	420	252	1540	45.50	97	2910	1843.7	2579.1	2579.1	3687.3
73	438	263	1606	47.45	93	3180	1990.7	2794.9	2794.9	3991.3

STUD LINK ANCHOR CHAIN (METRIC)

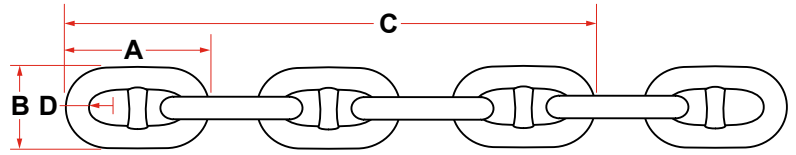

CHAIN NOMINAL DIAMETER	LINK LENGTH (A)	LINK WIDTH (B)	LENGTH OF 5 LINKS (C)	GRIP RADIUS (D)	LINKS PER SHOT	WEIGHT PER SHOT	GRADE 2		GRADE 3	
							PROOF LOAD	BREAKING LOAD	PROOF LOAD	BREAKING LOAD
mm	mm	mm	mm	mm	ea	kg	kN	kN	kN	kN
76	456	274	1672	49.40	89	3470	2147.6	3010.6	3010.6	4295.3
78	468	281	1716	50.70	87	3650	2255.5	3157.7	3157.7	4501.3
81	486	292	1782	52.65	83	3930	2412.4	3383.3	3383.3	4824.9
84	504	302	1848	54.60	81	4250	2579.1	3608.8	3608.8	5158.3
87	522	313	1914	56.55	79	4560	2745.9	3854.0	3854.0	5501.5
90	540	324	1980	58.50	75	4860	2922.4	4089.4	4089.4	5844.8
92	552	331	2024	59.80	73	5100	3040.1	4256.1	4256.1	6080.1
95	570	342	2090	61.75	71	5400	3226.4	4511.0	4511.0	6443.0
97	582	349	2134	63.05	69	5670	3344.1	4677.8	4677.8	6688.1
100	600	360	2200	65.00	67	6010	3530.4	4942.6	4942.6	7060.8
102	612	367	2244	66.30	67	6250	3657.9	5119.1	5119.1	7315.8
105	630	378	2310	68.25	65	6600	3854.0	5393.7	5393.7	7698.2
107	642	385	2354	69.55	63	6820	3981.5	5570.2	5570.2	7963.0
111	666	400	2442	72.15	61	7290	4246.3	5942.8	5942.8	8482.8
114	684	410	2508	74.10	59	7640	4442.4	6227.2	6227.2	8894.6
117	702	421	2574	76.05	57	7980	4648.4	6511.6	6511.6	9296.7
120	720	432	2640	78.00	57	8310	4854.3	6805.8	6805.8	9718.4
122	732	439	2684	79.30	55	8620	5001.4	7001.9	7001.9	9993.0
124	744	446	2728	80.60	55	8920	5138.7	7198.1	7198.1	10277.4
127	762	457	2794	82.55	53	9380	5354.4	7492.3	7492.3	10708.9
130	780	468	2860	84.50	51	9840	5570.2	7796.3	7796.3	11140.4
132	792	475	2904	85.80	51	10140	5717.3	8002.2	8002.2	11424.7
137	822	493	3014	89.05	49	10910	6080.1	8512.2	8512.2	12160.2
142	852	511	3124	92.30	47	11670	6452.8	9031.9	9031.9	12905.6
147	882	529	3234	95.55	47	12440	6835.2	9561.5	9561.5	13660.7
152	912	547	3344	98.80	45	13200	7217.7	10100.8	10100.8	14425.6
157	942	565	3454	102.05	43	14000	7600.2	10640.2	10640.2	15200.3
162	972	583	3564	105.30	41	14700	8002.2	11199.2	11199.2	15994.6

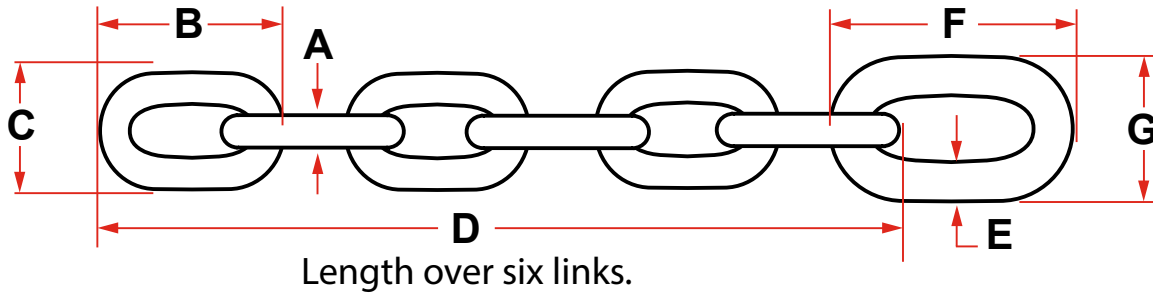

OPEN-LINK CHAIN (COAST GUARD BUOY CHAIN)

COMMON LINKS				END LINKS			LOADS		WEIGHT PER 15-FATHOM SHOT (APPROX.)	
WIRE DIAMETER A		LINK LENGTH (B)	LINK WIDTH (C)	LENGTH OVER SIX LINKS (D)	WIRE DIAMETER (E)	LINK LENGTH (F)	LINK WIDTH (G)	PROOF TEST		BREAK TEST
INCHES	MM									
1/2	13	3	1-7/8	13	3/4	4-1/4	2-5/8	7500	15000	210
5/8	16	3-3/4	2-1/4	16-1/4	3/4	4-1/2	2-5/8	11500	23000	323
3/4	19	4-1/2	2-5/8	19-1/2	7/8	5-1/4	3-1/8	16000	32000	442
7/8	22	5-1/4	3-1/8	22-3/4	1-1/8	6-3/4	3-7/8	22000	40000	608
1	25	6	3-1/2	28	1-1/4	7-1/2	4-3/8	29000	58000	760
1-1/8	28	6-3/4	3-7/8	29-1/4	1-1/4	7-1/2	4-3/8	38500	77000	990
1-1/4	32	7-1/2	4-3/8	32-1/2	1-1/2	9	5-1/4	45500	91000	1245
1-1/2	38	9	5-1/4	39	1-7/8	11-1/4	6-1/2	65500	131000	1762
1-5/8	42	9-3/4	5-11/16	42-1/4	1-7/8	11-1/4	6-1/2	76500	153000	2040
1-3/4	44	10-1/2	6-1/16	45-1/2	2-1/8	12	7-3/16	86500	173000	2370
1-7/8	48	11-1/4	6-1/2	48-3/4	2-1/8	12	7-3/16	100000	200000	2640

All specifications in pounds and inches, unless otherwise stated.

PROOF COIL CHAIN GRADE 28 / GRADE 30



CAUTION: NEVER EXCEED WORK LOAD LIMIT OF CHAIN. NEVER USE PROOF COIL CHAIN FOR OVERHEAD LIFTING OR WHERE IT'S FAILURE WILL CAUSE DAMAGE TO PROPERTY OR LIFE.

PROOF COIL CHAIN (GRADE 28)

Self colored-zinc plated-hot galvanized

TRADE SIZE	WORK LOAD LIMIT IN LBS	FEET PER DRUM	FEET PER 1/2 DRUM	MIN. WEIGHT PER FOOT IN LBS	MAX. LENGTH PER 100 LINKS
1/8"	375	—	1,000	.17	98.7"
3/16"	750	1,500	750	.33	96.4"
1/4"	1,250	800	400	.63	124"
5/16"	1,900	550	275	.93	129.1"
3/8"	2,650	400	200	1.41	137.8"
7/16"	3,500	300	150	2.10	172.9"
1/2"	4,500	200	100	2.40	179.1"
5/8"	6,900	150	75	3.58	220.5"
3/4"	9,750	100	50	5.48	275.6"
7/8"	11,375	75	35	7.31	258.7"
1"	13,950	60	30	9.41	287.8"

HIGH TEST CHAIN GRADE 43 / GRADE 40



CAUTION: NEVER EXCEED WORK LOAD LIMIT OF CHAIN. NEVER USE GRADE 43 TEST CHAIN FOR OVERHEAD LIFTING OR WHERE IT'S FAILURE WILL CAUSE DAMAGE TO PROPERTY OR LIFE.

HIGH TEST CHAIN (GRADE 43)

Self colored-hot galvanized

TRADE SIZE	WORK LOAD LIMIT IN LBS	FEET PER DRUM	FEET PER 1/2 DRUM	MIN. WEIGHT PER FOOT IN LBS	MAX. LENGTH PER 100 LINKS
1/4"	2,600	800	400	.63	124.0"
5/16"	3,900	550	275	.93	129.1"
3/8"	5,400	400	200	1.41	137.8"
7/16"	7,200	300	150	2.10	172.9"
1/2"	9,200	200	100	2.40	179.1"
5/8"	11,500	150	75	3.58	220.5"
3/4"	16,200	100	50	5.48	275.6"

TRANSPORT CHAIN GRADE 70



CAUTION: NEVER EXCEED WORK LOAD LIMIT OF CHAIN. NEVER USE GRADE 70 CHAIN FOR OVERHEAD LIFTING OR WHERE IT'S FAILURE WILL CAUSE DAMAGE TO PROPERTY OR LIFE.

TRADE SIZE	WORK LOAD LIMIT IN LBS	FEET PER DRUM	FEET PER 1/2 DRUM	MIN. WEIGHT PER FOOT IN LBS	MAX. LENGTH PER 100 LINKS
1/14"	3,150	800	400	0.63	124.0"
5/16"	4,700	550	275	0.93	129.1"
3/8"	6,600	400	200	1.41	137.8"
1/2"	11,300	200	100	2.40	179.1"

ALLOY STEEL CHAIN GRADE 80



MATERIAL	DIAMETER		LINK DIMENSIONS INSIDE		WLL	LINKS PER FT.	WEIGHT PER 100' LBS.
	NOMINAL IN.	ACTUAL IN.	ACTUAL MM.	LENGTH IN.			
1/4"	.236	6	.70	.315	2,100	16.9	53
9/32"	.275	7	.82	.394	3,500	14.5	74
5/16"	.314	8	.94	.469	4,500	12.7	94
3/8"	.393	10	1.18	.575	7,100	10.1	148
1/2"	.512	13	1.53	.764	12,000	7.8	256
5/8"	.629	16	1.89	.937	18,100	6.3	383
3/4"	.787	20	2.36	1.142	28,300	5.1	605
7/8"	.866	22	2.60	1.307	34,200	4.6	732
1"	1.020	26	3.07	1.379	47,700	3.9	1,020
1-1/4"	1.260	32	3.78	1.713	72,300	3.1	1,550
1-1/2"	1.490	38	4.48	2.000	99,000	2.6	2,090

ALLOY STEEL CHAIN GRADE 100



MATERIAL	DIAMETER	DIAMETER	LINK DIMENSIONS INSIDE		WLL	LINKS	WEIGHT PER 100'
NOMINAL IN.	ACTUAL IN.	ACTUAL MM.	LENGTH IN.	WIDTH IN.	LBS	PER FT.	LBS.
9/32"	.275	7	.82	.394	4,300	14.5	74
5/16"	.314	8	.94	.469	5,700	12.7	94
3/8"	.393	10	1.18	.575	8,800	10.1	148
1/2"	.512	13	1.53	.764	15,000	7.8	256
5/8"	.629	16	1.89	.937	22,600	6.3	383

STAINLESS STEEL CHAIN



TRADE SIZE	DRUM	WORKING LOAD LIMITS (LBS)	MATERIAL DIAMETER (IN)	INSIDE LENGTH (IN)	INSIDE WIDTH (IN)	WEIGHT PER 100 FT (LBS)
1/8"	1000'	375	.156	.94	.25	17
3/16"	1500'	1,150	.217	.98	.30	38
1/4"	800'	1,860	.275	1.24	.38	61
5/16"	550'	2,425	.330	1.29	.44	84
3/8"	400'	3,800	.394	1.38	.55	140
1/2"	200'	6,425	.512	1.79	.72	234
5/8"	150'	9,725	.630	2.20	.79	358
3/4"	60'	15,175	.787	2.76	.98	551

DO NOT USE FOR OVERHEAD LIFTING. Do not exceed working load limit.

The information on this page is to be used for comparison purposes only.
Please consult reliable engineering texts when danger to life or property is possible.

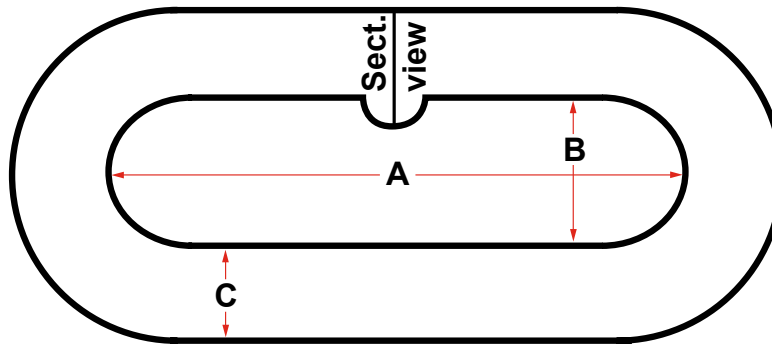

Typical Link

FINISH: HOT DIPPED GALVANIZED

LONG LINK HIGH TEST CHAIN G-43

NOMINAL CHAIN SIZE INCHES	WEIGHT PER 100' (LBS)	C (IN)	A (IN)	B (IN)	WORKING LOAD (LBS)	PROOF LOAD (LBS)	BREAKING STRENGTH (LBS)
3/8"	117	3/8"	2-3/8"	5/8"	3,500	7,000	14,000
1/2"	186	1/2"	3-1/4"	3/4"	6,000	12,000	24,000
5/8"	290	5/8"	3-3/4"	7/8"	9,500	19,000	38,000
3/4"	460	3/4"	3-3/4"	1-1/4"	13,500	27,000	54,000
1"	832	1"	4-1/8"	1-3/8"	23,200	46,400	92,800

LONG LINK LASHING CHAIN G-70

NOMINAL CHAIN SIZE INCHES	WEIGHT PER 100' (LBS)	C (IN)	A (IN)	B (IN)	WORKING LOAD (LBS)	PROOF LOAD (LBS)	BREAKING STRENGTH (LBS)
1/2"	202	1/2"	3-1/8"	1"	10,000	20,000	39,000

LONG LINK ALLOY CHAIN G-80

NOMINAL CHAIN SIZE INCHES	WEIGHT PER 100' (LBS)	C (IN)	A (IN)	B (IN)	WORKING LOAD (LBS)	PROOF LOAD (LBS)	BREAKING STRENGTH (LBS)
3/8"	143	3/8"	2-3/8"	1/2"	7,100	14,200	28,400
1/2"	231	1/2"	3-1/4"	3/4"	10,000	20,000	40,000
5/8"	290	5/8"	3-3/4"	7/8"	17,500	35,000	70,000
3/4"	506	3/4"	3-3/4"	1-1/4"	27,500	55,000	110,000
1"	902	1"	4-1/8"	1-3/8"	43,400	86,800	173,600

CHAIN & ANCHOR FITTINGS

- DETACHABLE CHAIN CONNECTING LINKS
- KENTER JOINING SHACKLES
- JAW & JAW SWIVEL SHACKLES
- ROUND PIN ANCHOR SHACKLES
- DETACHABLE ANCHOR CONNECTING LINKS
- OVAL PIN JOINING SHACKLES
- PAWL TYPE CHAIN STOPPERS
- PELICAN HOOK CHAIN STOPPER ASSEMBLIES
- DEVIL'S CLAW CHAIN STOPPER ASSEMBLIES
- END SHACKLES
- END LINKS
- SWIVELS
- HINGE LINKS

We also maintain a large inventory of used and surplus, imported and domestic, anchor chain attachments.

GIVE US A CALL

310.522.9698

FAX 310.522.1043



COUPLING TO THE ANCHOR

A1		<p>A) COMMON LINK B) ENLARGED LINK C) END LINK D) KENTER LINK E) JOINING SHACKLE F) END SHACKLE G) SWIVEL ASSEMBLY H) JAW & JAW SWIVEL SHACKLE J) PEAR ANCHOR JOINING LINK K) DETACHABLE CONNECTING LINK</p>
A2		
A3		
A4		
A5		
A6		
A7		
A8		

COUPLING TO THE ANCHOR

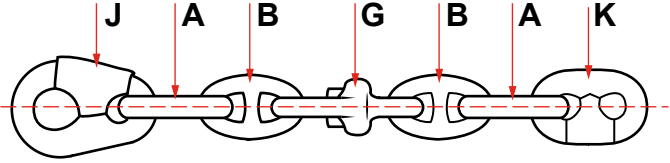
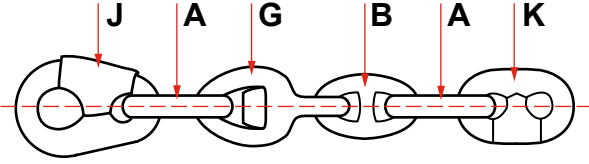
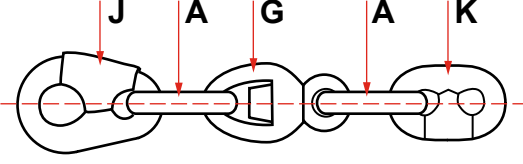
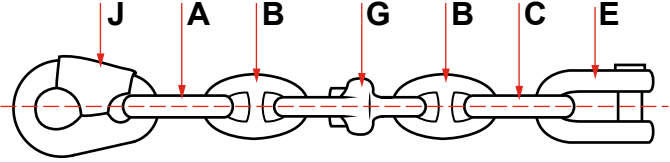
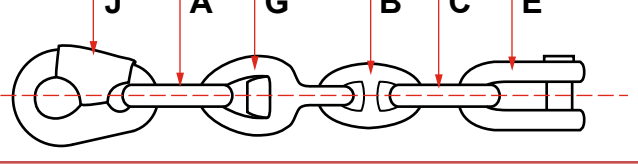
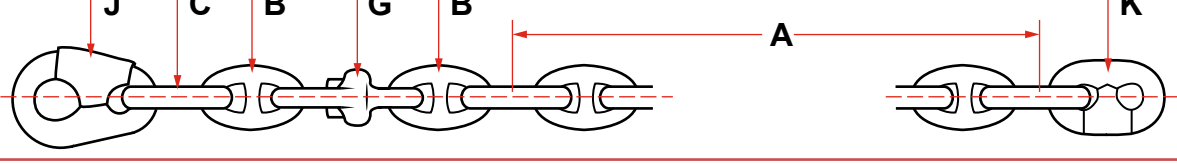
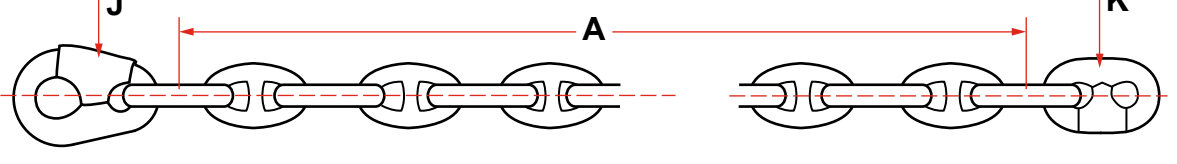
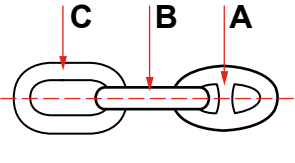
<p>A9</p>		<p>A) COMMON LINK B) ENLARGED LINK C) END LINK D) KENTER LINK E) JOINING SHACKLE F) END SHACKLE G) SWIVEL ASSEMBLY H) JAW & JAW SWIVEL SHACKLE J) PEAR ANCHOR JOINING LINK K) DETACHABLE CONNECTING LINK</p>
<p>A10</p>		
<p>A11</p>		
<p>A12</p>		
<p>A13</p>		
<p>A14</p>		
<p>A15</p>		
<p>A16</p>	 <p>Normal adaptor piece</p>	

COUPLING IN THE CHAIN LOCKER

<p>A) COMMON LINK B) ENLARGED LINK C) END LINK D) KENTER LINK E) JOINING SHACKLE F) END SHACKLE G) SWIVEL ASSEMBLY H) JAW & JAW SWIVEL SHACKLE J) PEAR ANCHOR JOINING LINK K) DETACHABLE CONNECTING LINK</p>		<p>B1</p>
		<p>B2</p>
		<p>B3</p>
		<p>B4</p>
		<p>B5</p>
		<p>B6</p>
		<p>B7</p>

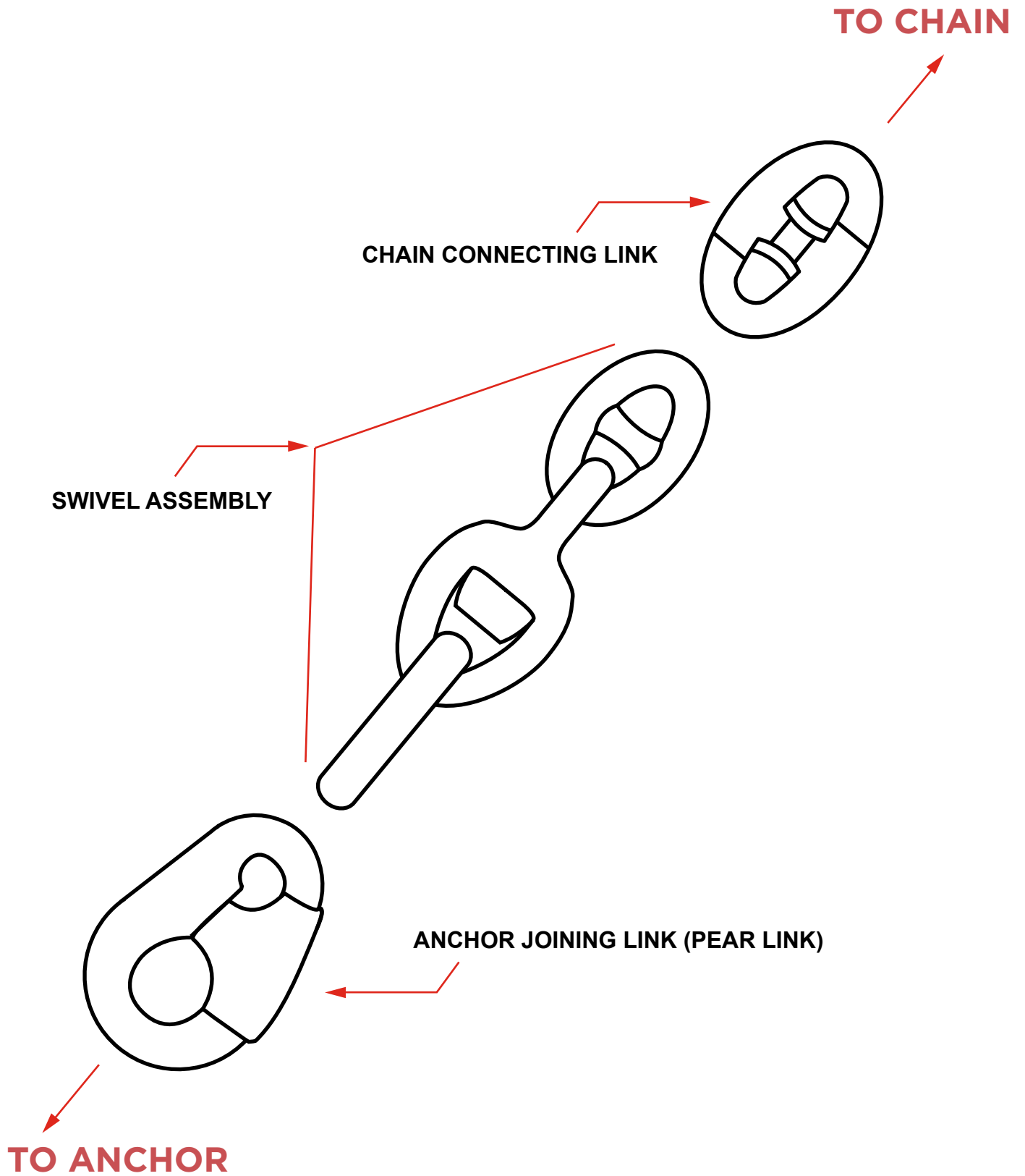

KENTER JOINING LINK ASSEMBLY

The Kenter-type joining link contains three parts plus taper pin and lead plug. The two main halves have numbers to be matched and arrows to be lined up for ease of assembly with the third piece (stud). The two main parts are attached to the ends of the chain in a vertical position and then fitted together (1), and the stud is then slid into place (2), which locks the link. The stud is secured by hammering a tapered pin into the hole drilled diagonally (3) through all three parts of the joining link. This hole is tapered, and when the pin is driven home, a small conical recess (called the “dovetail chamber”) is left clear above its head. A lead pellet is hammered broad end first into this chamber (4) so as to fill it completely and thereby keep the pin in place. Precaution must be used to prevent flat, small pieces of lead from flying off the joining link into the face or eyes.

Prior to assembly, the internal mating surfaces should be coated with molybdenum disulphide grease (MIL-G-23529) or an equivalent lithium based grease. When assembling and before inserting the new lead, any remaining lead must be reamed out. When disassembling, the locking pin is driven out with a “drift.” To part the link, a top swage (shaped to the curvature of the link) must always be used between the hammer and link so as to avoid damaging the machined surfaces.

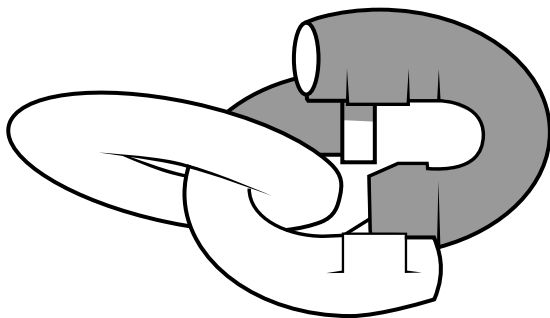

(1) After inserting the first half of the link through chain, the other link is inserted in the other and driven together.

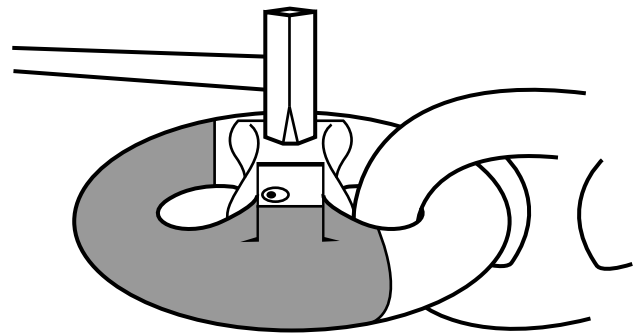

(2) The center stud is inserted.

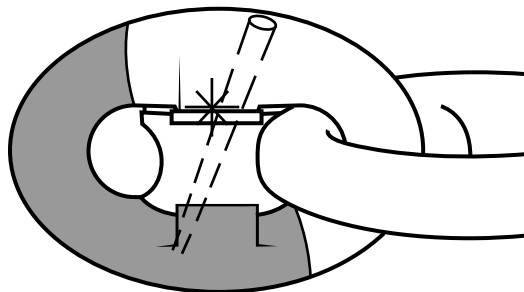

(3) When the center chock is in correct position the taper pin can without a hammer be inserted as shown on the figure which also shows the center chock in correct position.

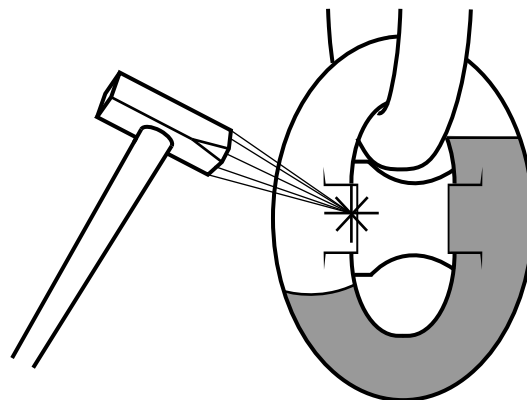

(4) The taper pin is driven in and is secured by the lead pellet which is inserted into place with a hammer.

KENTER JOINING SHACKLE (METRIC)

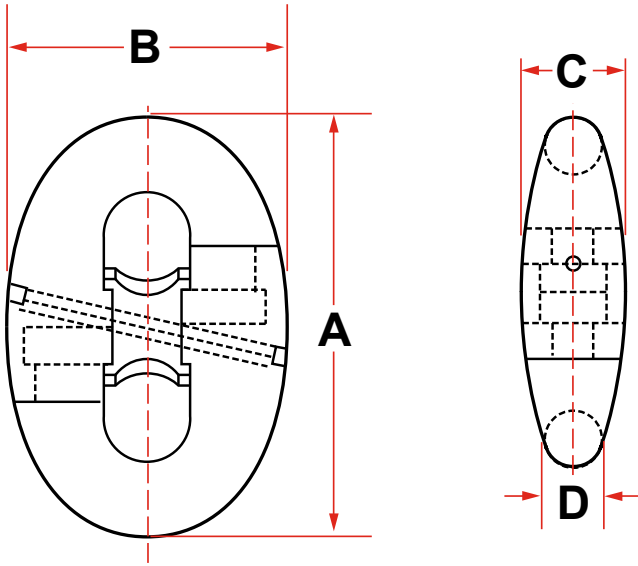

NOMINAL DIAMETER (D)	A	B	C	WEIGHT
mm	mm	mm	mm	kg
12.5	75	53	19	0.45
14	84	59	21	0.6
16	96	67	24	0.65
17.5	105	74	27	0.88
19	114	80	29	1.13
20.5	123	86	31	1.36
22	132	92	33	1.64
24	144	101	36	2.13
26	156	109	40	2.58
28	168	118	43	3.3
30	180	126	46	4.15
32	192	134	49	5.06
34	204	143	52	6.01
36	216	151	55	6.89
38	228	160	58	8.4
40	240	168	61	9.63
42	252	176	64	11
44	264	185	67	12.45
46	276	193	70	14.1
48	288	202	73	16.7
50	300	210	76	19
52	312	218	79	20.3
54	324	227	82	23.7
56	336	235	85	26.7

Continued

NOMINAL DIAMETER (D)	A	B	C	WEIGHT
mm	mm	mm	mm	kg
58	348	244	88	27.2
60	360	252	91	27.7
62	372	260	94	35
64	384	269	97	38.4
66	396	277	100	42.3
68	408	286	103	46
70	420	294	106	48.7
73	438	307	111	53
76	456	319	116	60.7
78	468	328	119	65.5
81	486	340	123	75
84	504	353	128	90
87	522	365	132	96
90	540	378	137	108
92	552	386	140	114
95	570	399	144	128
97	582	407	147	133
100	600	420	152	146
102	612	428	155	158
105	630	441	160	160
107	642	449	163	180
111	666	466	169	198
114	684	479	173	204

Loads match that of same diameter SLAC.

KENTER JOINING SHACKLE (IMPERIAL)

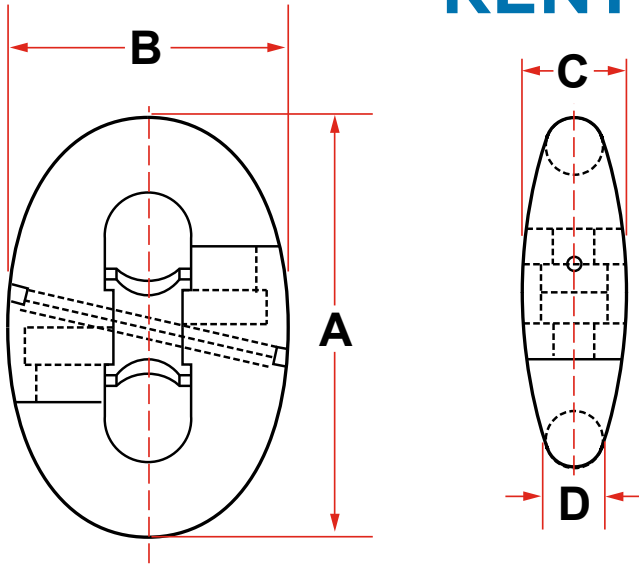

NOMINAL DIAMETER (D)	A	B	C	WEIGHT
In	In	In	In	Lbs
1/2	3.0	2.1	0.8	1.0
9/16	3.4	2.4	0.9	1.3
5/8	3.8	2.6	1.0	1.4
11/16	4.1	2.9	1.0	1.9
3/4	4.5	3.2	1.1	2.4
13/16	4.9	3.4	1.2	2.9
7/8	5.3	3.7	1.3	3.5
15/16	5.6	3.9	1.4	4.6
1	6.0	4.2	1.5	5.7
1 1/16	6.4	4.5	1.6	6.6
1 1/8	6.8	4.7	1.7	7.7
1 3/16	7.1	5.0	1.8	9.2
1 1/4	7.5	5.3	1.9	10.6
1 5/16	7.9	5.5	2.0	12.8
1 3/8	8.3	5.8	2.1	14.3
1 7/16	8.6	6.0	2.2	16.5
1 1/2	9.0	6.3	2.3	18.5
1 9/16	9.4	6.6	2.4	21.0
1 5/8	9.8	6.8	2.5	24.2
1 11/16	10.1	7.1	2.6	27.1
1 3/4	10.5	7.4	2.7	29.8
1 13/16	10.9	7.6	2.8	33.0
1 7/8	11.3	7.9	2.9	36.4
1 15/16	11.6	8.1	2.9	39.7
2	12.0	8.4	3.0	45.2
2 1/16	12.4	8.7	3.1	49.2
2 1/8	12.8	8.9	3.2	53.4
2 3/16	13.1	9.2	3.3	58.0
2 1/4	13.5	9.5	3.4	62.8
2 5/16	13.9	9.7	3.5	67.9

Continued

NOMINAL DIAMETER (D)	A	B	C	WEIGHT
In	In	In	In	Lbs
2 3/8	14.3	10.0	3.6	75.0
2 7/16	14.6	10.2	3.7	80.9
2 1/2	15.0	10.5	3.8	86.8
2 9/16	15.4	10.8	3.9	93.3
2 5/8	15.8	11.0	4.0	99.9
2 11/16	16.1	11.3	4.1	107
2 3/4	16.5	11.6	4.2	114
2 13/16	16.9	11.8	4.3	124
2 7/8	17.3	12.1	4.4	132
2 15/16	17.6	12.3	4.5	140
3	18.0	12.6	4.6	149
3 1/16	18.4	12.9	4.7	158
3 1/8	18.8	13.1	4.8	170
3 3/16	19.1	13.4	4.8	180
3 1/4	19.5	13.7	4.9	191
3 5/16	19.9	13.9	5.0	201
3 3/8	20.3	14.2	5.1	215
3 7/16	20.6	14.4	5.2	227
3 1/2	21.0	14.7	5.3	238
3 9/16	21.4	15.0	5.4	251
3 5/8	21.8	15.2	5.5	262
3 3/4	22.5	15.8	5.7	289
3 7/8	23.3	16.3	5.9	324
3 15/16	23.6	16.5	6.0	340
4	24.0	16.8	6.1	355
4 1/8	7.5	5.3	1.9	395
4 1/4	25.5	17.9	6.5	428
4 3/8	26.3	18.4	6.7	465
4 1/2	27.0	18.9	6.8	509

Loads match that of same diameter SLAC.

DETACHABLE CHAIN CONNECTING LINK

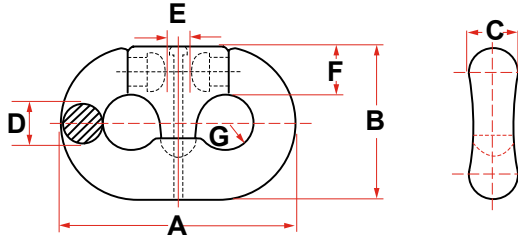

GRADE 3

CHAIN SIZE		A	B	C	D	E	F	G	WEIGHT		PROOF TEST	BREAK TEST
MM	INCHES	MM	MM	MM	MM	MM	MM	MM	KG.	LBS.	KGf	KGf
13 - 16	1/2 - 5/8	95	63	22	16	19	21	12	0.5	1.0	14651	23668
19	3/4	114	74	24	19	22	24	13	1.0	2.0	21771	34020
21 - 22	13/16 - 7/8	133	86	28	22	25	28	16	1.5	3.5	29030	44452
24 - 25	15/16 - 1	152	102	35	25	29	31	17	2.3	5.1	38000	54300
27 - 29	1-1/16 - 1-1/8	172	114	40	29	32	35	19	3.3	7.3	49200	70400
30 - 32	1-3/16 - 1-1/4	191	127	44	32	36	39	21	4.6	10.1	59500	84900
33 - 35	1-5/16 - 1-3/8	210	140	48	35	40	43	23	6.2	13.7	70700	101300
36 - 38	1-7/16 - 1-1/2	229	152	53	38	43	47	26	7.9	17.4	83300	118900
40 - 42	1-9/16 - 1-5/8	248	165	57	42	47	50	28	10.0	22.0	102000	143400
43 - 44	1-11/16 - 1-3/4	267	178	62	44	50	56	30	12.5	27.6	111900	159900
46 - 48	1-13/16 - 1-7/8	286	191	64	48	55	60	32	14.5	32.0	130000	185100
50 - 51	1-15/16 - 2	305	197	64	51	59	64	34	16.3	35.9	145400	207700
52 - 54	2-1/16 - 2-1/8	324	209	67	54	63	68	36	20.0	44.1	162000	231500
56 - 58	2-3/16 - 2-1/4	343	222	71	58	66	71	38	23.6	52.0	185400	265000
59 - 60	2-5/16 - 2-3/8	364	235	78	60	70	76	41	28.0	61.7	199600	285200
62 - 64	2-7/16 - 2-1/2	381	246	79	64	74	79	43	32.2	71.0	223000	319000
66 - 67	2-9/16 - 2-5/8	400	259	83	67	77	83	45	37.0	81.6	242900	347000
68 - 70	2-11/16 - 2-3/4	419	271	87	70	81	87	47	45.0	99.2	263500	376400
71 - 73	2-13/16 - 2-7/8	438	283	91	73	85	91	49	49.0	108.0	285000	407000
75 - 76	2-15/16 - 3	457	296	95	76	88	95	51	55.0	121.0	308200	440200
78 - 79	3-1/16 - 3-1/8	476	308	99	79	92	99	53	63.0	139.0	332100	474500
81 - 83	3-3/16 - 3-1/4	495	320	103	83	96	103	55	73.0	161.0	360400	514800
84 - 86	3-5/16 - 3-3/8	514	333	107	86	99	107	57	80.0	176.0	384400	549100
87 - 89	3-7/16 - 3-1/2	533	345	111	89	103	111	60	93.0	205.0	409000	584300
90 - 92	3-9/16 - 3-5/8	553	357	115	92	107	115	62	97.6	215.0	434800	621200
94 - 95	3-11/16 - 3-3/4	572	370	119	95	111	119	64	116.2	256.0	462300	660100
97 - 98	3-13/16 - 3-7/8	591	382	128	98	114	123	66	123.0	271.0	490000	700000
100 - 102	3-15/16 - 4	610	394	132	102	118	127	68	131.0	289.0	522100	746000
105	4-1/8	629	419	147	105	127	132	70	175.0	386.0	550000	785000
111	4-3/8	667	456	167	111	138	140	75	208.0	459.0	607000	867200
114	4-1/2	686	480	190	114	147	144	77	227.0	500.0	637300	910900

To convert to lbs., multiply by 2.2046

PEAR SHAPED ANCHOR JOINING LINK

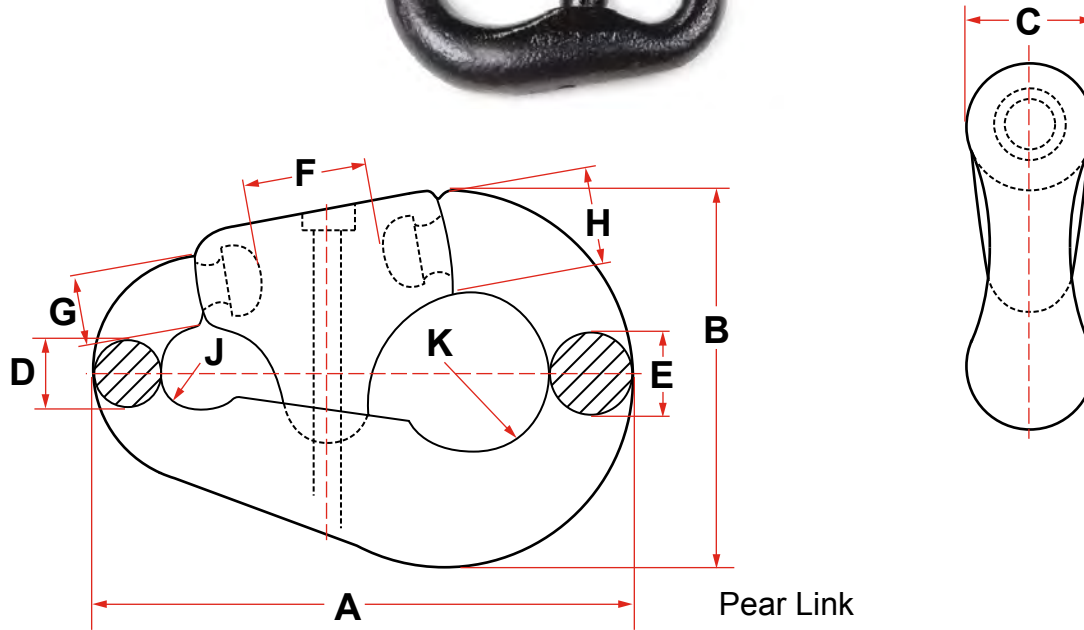

GRADE 3

No.	CHAIN SIZE		A	B	C	D	E	F	G	H	J	K	WEIGHT		PROOF TEST	BREAK TEST
	MM	INCHES	MM	MM	MM	MM	MM	MM	MM	MM	MM	MM	KG	LBS	KGF	KGF
2	19-24	3/4 - 15/16	194	132	38	24	32	57	24	35	17	30	3.6	8	34000	48500
3	25-30	1 - 1-3/16	238	167	46	30	38	66	33	45	19	35	6.5	14	53000	75700
4	32-40	1-1/4 - 1-9/16	299	206	59	40	48	83	40x45	56	26	43	14.5	32	91400	131000
5	42-51	1-5/8 - 2	378	260	76	51	64	100	51x60	74	32	52	27.0	60	145400	207700
6	52-60	2-1/16 - 2-3/8	454	313	92	60	76	121	62x73	88	37	64	49.0	107	199600	285200
7	62-79	2-7/16 - 3-1/8	562	376	121	79	95	149	86x79	111	48	76	92.0	203	332100	474500
8	81-92	3-3/16 - 3-5/8	654	419	133	92	124	149	111x102	130x133	54	79	149.0	328	434800	621200
9	94-95	3-11/6 - 3-3/4	692	435	146	98	130	159	124x137	141	57	83	236.0	520	462300	660100
10	97-102	3-13/16 - 4	889	572	191	121	165	191	130x148	181	73	108	386.0	850	522100	746000
11	103-108	4-1/16 - 4-1/4	940	610	203	127	175	203	156	200	76	111	418.0	920	577000	825000
12	110-114	4-5/16 - 4-1/2	991	648	216	133	184	216	165x167	210x200	105	114	459.0	1010	637300	910900

To convert to lbs., multiply by 2.2046

PEAR SHAPED ANCHOR JOINING LINKS GRADE ORQ & R4

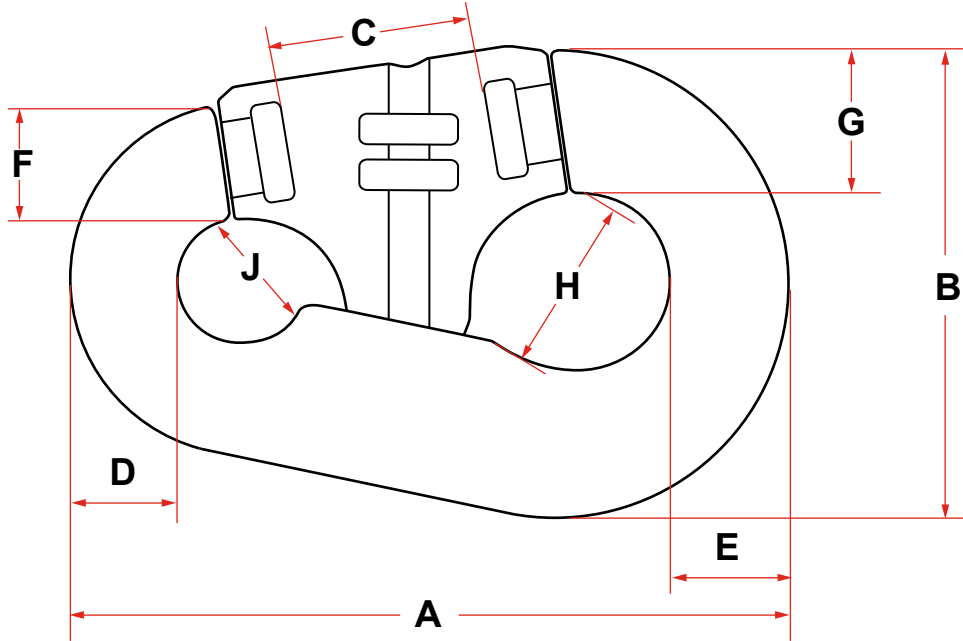

NO.	CHAIN SIZE (MM)	DIMENSIONS (MM)								
		A	B	C	D	E	F	G	H	J
4	32 - 40	298	207	89	41	50	45	60	83	52
5	42 - 51	380	264	100	52	65	60	84	109	65
6	52 - 60	480	337	125	66	83	81	103	142	86
7	62 - 79	570	370	155	85	96	92	113	140	98
8	81 - 92	655	430	162	99	129	119	131	162	115
10	97 - 102	900	580	192	127	168	151	181	207	150

NO.	GRADE R4		GRADE ORQ	
	PROOF LOAD (KN)	BREAK LOAD (KN)	PROOF LOAD (KN)	BREAK LOAD (KN)
4	1410	1789	914	1377
5	2243	2845	1454	2191
6	3048	3867	1976	2978
7	5079	6443	3292	4962
8	6699	8497	4342	6544
9	7096	9001	4599	6932
10	8054	10217	5220	7868

To convert to lbs., multiply by 225

SWIVEL FORERUNNER (2-LINK)

ABS CERTIFICATES

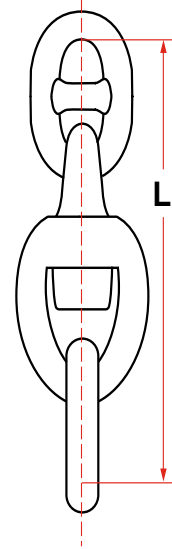
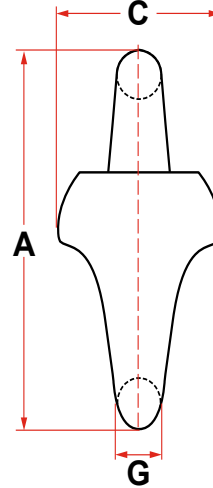
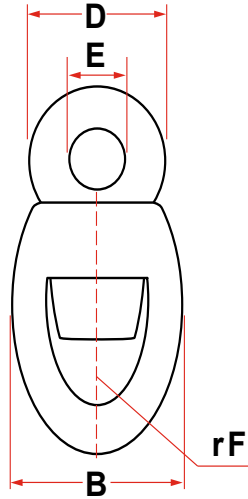

GRADE 3

CHAIN SIZE		A	B	C	D	E	F	G	L	WEIGHT (C+SW+C)		PROOF TEST	BREAK TEST
mm	Inches	mm	mm	mm	mm	mm	mm	mm	mm	kg	Lbs	KGF	KGF
30-35	1-3/16 - 1-3/8	290	160	124	116	46	25	36	499	21.0	46.3	70700	101300
36-42	1-7/16 - 1-5/8	373	202	146	145	63	32	46	622	39.5	87.1	102000	143400
43-48	1-11/16 - 1-7/8	430	230	165	183	73	36	50	709	66.0	145.5	130000	185100
49-58	1-15/16 - 2-1/4	516	278	200	212	84	39	65	851	104.0	229.3	185400	265000
59-67	2-5/16 - 2-5/8	575	307	230	235	93	46	68	972	142.0	313.1	242900	347000
68-73	2-11/16 - 2-7/8	650	345	260	256	102	50	79	1078	208.0	458.6	285000	407000
75-79	2-15/16 - 3-1/8	757	370	325	281	109	52	94	1209	276.0	608.5	332100	474500
81-86	3-3/16 - 3-3/8	760	420	372	310	122	57	95	1260	336.0	740.8	384400	549100
87-92	3-7/16 - 3-5/8	800	430	390	320	130	60	98	1343	376.0	828.9	434800	621200
94-98	3-11/16 - 3-7/8	882	460	433	354	142	66	118	1442	557.0	1228.0	490000	700000
100-102	3-15/16 - 4	918	480	448	368	148	69	122	1502	612.0	1349.0	522100	746000
105-111	4-1/8 - 4-3/8	1000	530	478	400	160	74	133	1635	797.0	1757.0	607000	867200
114	4-1/2	1026	542	490	417	165	76	137	1675	871.0	1920.0	637300	910900

To convert load to lbs., multiply by 2.2046

Cast Steel
Made in Argentina

SWIVEL FORERUNNER (3-LINK)

ABS CERTIFICATES

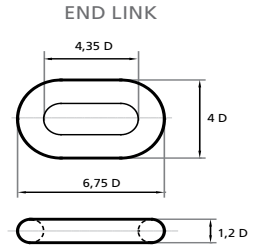
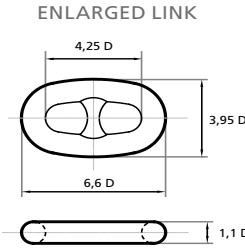
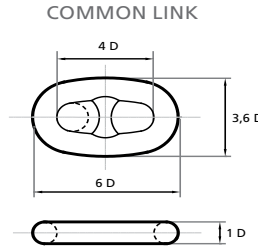
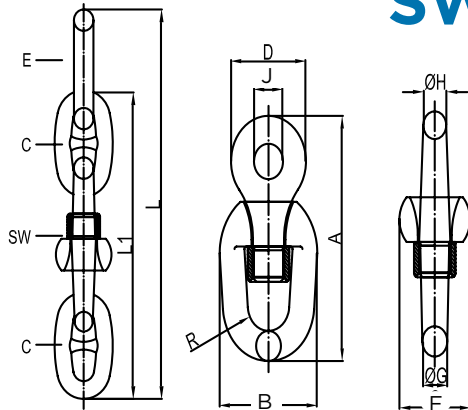

NOMINAL SIZE		A	B	D	J	R	F	G	H	L	L1	APPROX WEIGHT(L)	
Inches	MM	MM	MM	MM	MM	MM	MM	MM	MM	MM	MM	KG	LBS
1/2	12.5	121	59	44.8	18	13	43	15	13.5	274	218	1.8	3.9
9/16	14	136	66	50.2	20	14	48	17	15.1	307	244	2.5	5.6
5/8	16	155	75	57.3	23	16	55	19	17	351	278	3.6	7.9
11/16	17.5	170	82	62.7	25	18	60	21	18.9	384	305	4.7	10
3/4	19	184	89	68.1	27	19	65	23	20.5	417	331	5.8	13
7/8	22	214	104	78.8	31	22	75	27	23.8	483	383	7.2	16
15/16	24	233	113	86	34	24	82	29	26	527	418	9.0	20
1	26	252	122	93.2	37	26	89	31	28.1	571	452	12	26
1-1/8	28	272	132	100	40	28	96	34	30.3	615	487	15	32
1-3/8	30	291	141	108	43	30	103	36	32.5	659	522	18	39
1-1/4	32	310	151	115	45	32	109	39	34.6	702	557	21	46
1-5/16	34	330	160	122	48	34	116	41	36.8	746	592	25	56
1-3/8	36	349	170	129	51	36	123	44	39	790	626	31	67
1-1/2	38	369	179	136	54	38	130	46	41.1	834	661	35	77
1-5/8	42	407	198	151	60	42	144	51	45.5	922	731	48	106
1-3/4	44	427	207	158	62	44	150	53	47.6	966	766	54	118
1-7/8	48	466	226	172	68	48	164	58	52	1054	835	71	156
2	52	504	245	186	74	52	178	63	56.3	1141	905	89	197
2-1/8	54	524	254	194	77	54	185	65	58.5	1185	940	100	219
2-1/4	58	563	273	208	82	58	198	70	62.8	1273	1009	126	277
2-3/8	60	582	283	215	85	60	205	73	65	1317	1044	140	308
2-1/2	64	621	301	229	91	64	219	77	69.3	1405	1114	163	359
2-5/8	68	660	320	244	96	68	232	82	73.6	1493	1183	196	432
2-3/4	70	679	330	251	99	70	239	85	75.8	1537	1218	214	471
2-7/8	73	708	344	262	103	73	249	88	79.0	1602	1270	245	541
3	76	737	358	272	108	76	260	92	82.3	1668	1322	279	615
3-1/16	78	757	367	280	111	78	267	94	84.5	1712	1357	302	666
3-1/8	79	766	372	283	112	79	270	95	85.5	1734	1375	315	694
3-1/4	84	815	396	301	119	84	287	102	91	1844	1462	380	838
3-5/8	92	892	433	330	130	92	314	111	99.6	2019	1601	495	1091
4	102	989	480	366	145	102	349	123	110.5	2239	1775	669	1476

Loads match that of same diameter SLAC. Intermediate sizes will fit the next size up. Alternate configurations and specific sizes are available upon request. Exact dimensions may vary.

1/2" - 15/16" Available in Grade 2.
3/4" and up available in Grade 3.

SWIVEL FORERUNNER (4-LINK) ABS CERTIFICATES

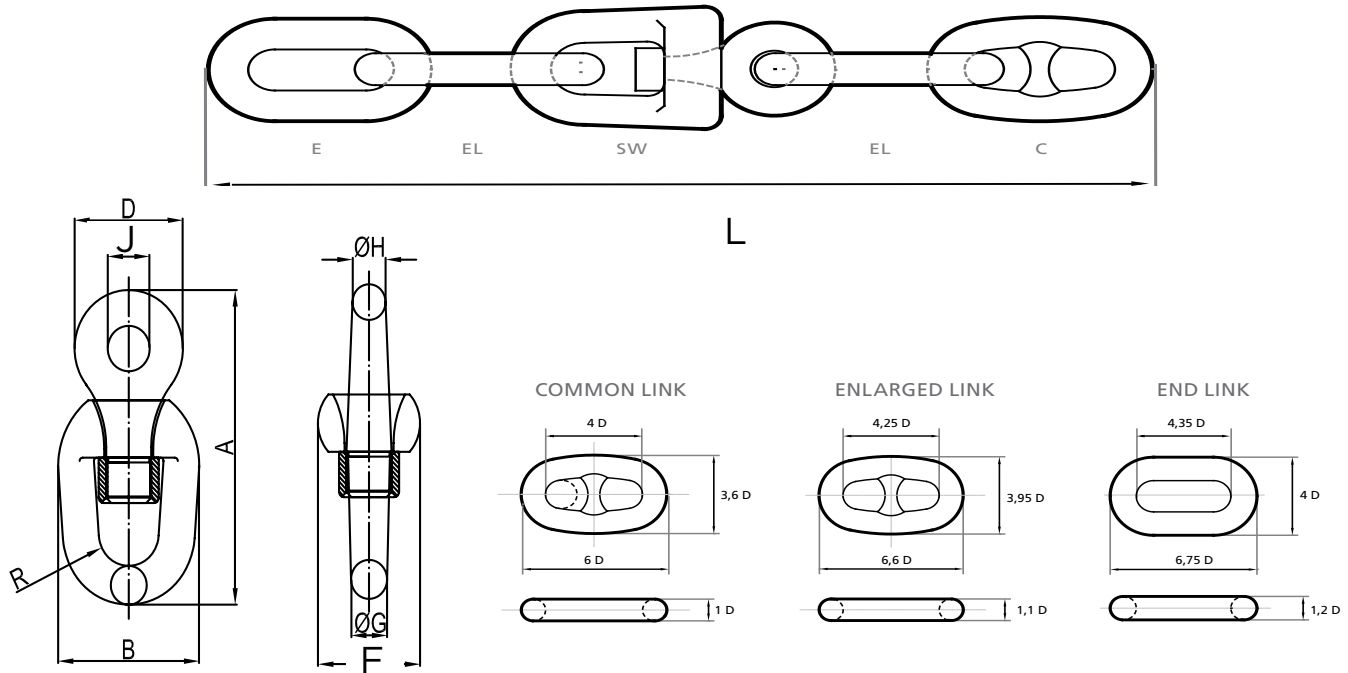

NOMINAL SIZE	A	B	D	J	R	F	G	H	L	APPROX WEIGHT	GRADE 2		GRADE 3	
											PROOF LOAD	BREAKING LOAD	PROOF LOAD	BREAKING LOAD
In	In	In	In	In	In	In	In	In	In	Lbs	Lbf	Lbf	Lbf	Lbf
1/2	4.9	2.4	1.8	0.7	0.5	1.7	0.6	0.6	13.2	4	15300	21400	21400	30600
9/16	5.5	2.6	2.0	0.8	0.6	1.9	0.7	0.6	14.9	6	19300	27000	27000	38600
5/8	6.1	2.9	2.3	0.9	0.6	2.1	0.8	0.7	16.5	8	23700	33200	33200	47500
11/16	6.7	3.2	2.5	1.0	0.7	2.3	0.8	0.8	18.2	10	28600	40100	40100	57300
3/4	7.3	3.5	2.7	1.1	0.8	2.6	0.9	0.8	19.8	13	34000	47600	47600	68000
7/8	8.5	4.1	3.0	3.2	1.2	0.9	1.1	1.0	23.1	18	46000	64400	64400	91800

1/2" - 15/16" Available in Grade 2.
 3/4" and up available in Grade 3.
 Loads match that of same diameter SLAC.
 Intermediated sizes will fit the next size up. Alternate configurations and specific sizes are available upon request. Exact dimensions may vary.

C-TYPE CHAIN CONNECTING LINK

GRADE R4

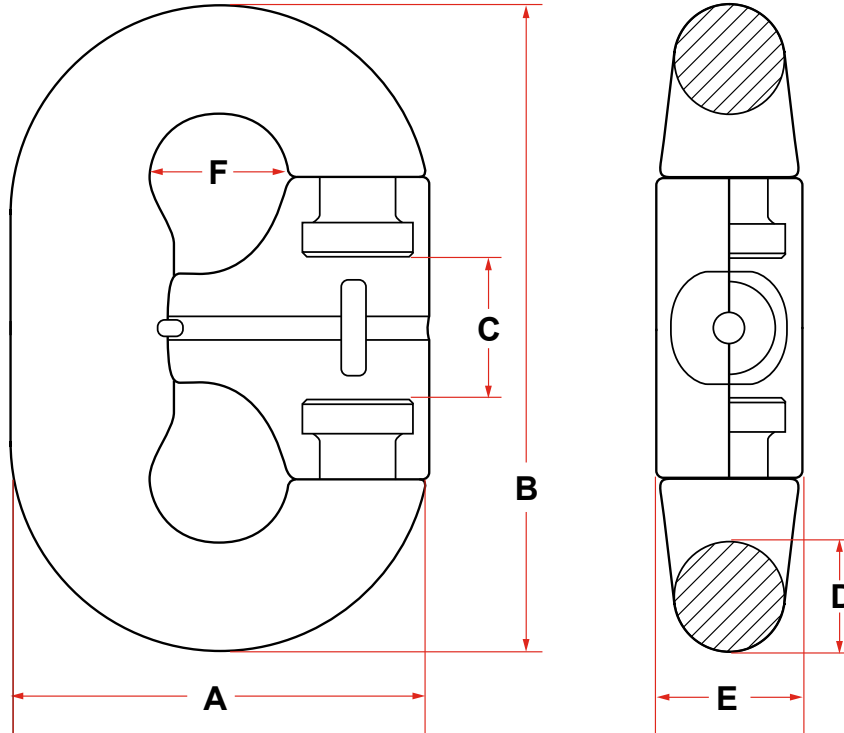

CHAIN SIZE	NOMINAL DIA	GRADE	PL (KN)	BL (KN)	DIMENSIONS (MM)						WEIGHT (KG)
					A	B	C	D	E	F	
52-54	54	R4	2500	3171	216	324	70	54	76	59	20
62-64	64	R4	3440	4364	256	384	83	64	89	70	30
68-70	70	R4	4064	5156	280	420	91	70	98	77	46
74-76	76	R4	4731	6001	304	456	99	76	106	84	62
83-86	83	R4	5559	7052	344	516	111	86	120	95	81
87-89	89	R4	6310	8004	356	534	116	89	125	98	93
95-96	95	R4	7231	9172	384	576	125	96	134	106	116

All measurements may vary slightly due to production but shall be within allowable tolerances to class society specifications.

KENTER JOINING SHACKLE

GRADE R4

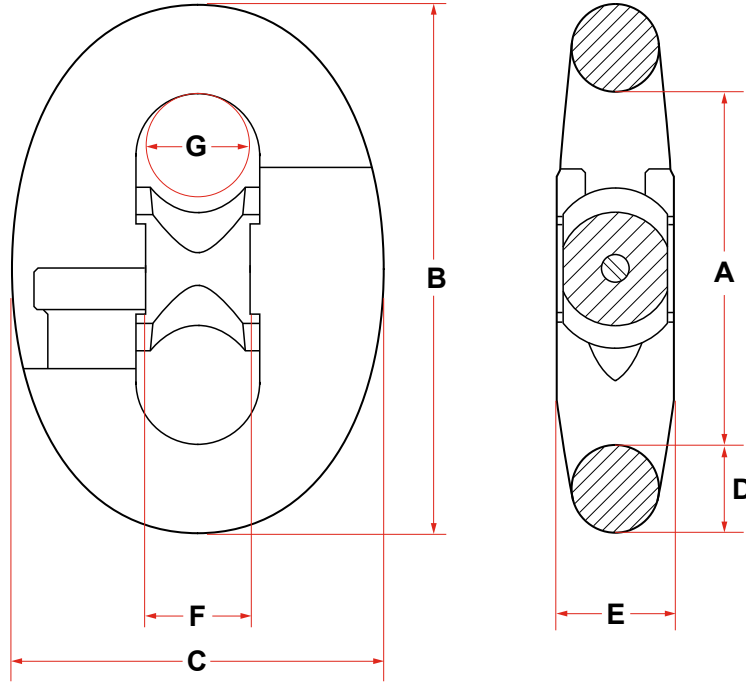

CHAIN SIZE	PL (kN)	BL (kN)	DIMENSIONS (MM)							WEIGHT (KG)
			A	B	C	D	E	F	G	
70	4064	5156	280	420	294	70	106	81	77	58
76	4731	6001	304	456	319	76	116	87	84	67
84	5682	7208	336	504	353	84	128	97	92	88
89	6310	8004	356	534	374	89	135	102	98	99
95	7096	9001	380	570	399	95	144	109	105	150
102	8054	10217	408	612	428	102	155	117	112	168
105	8478	10754	420	630	441	105	160	121	116	175
108	8909	11301	432	648	454	108	164	124	119	193
114	9791	12420	456	684	479	114	173	131	125	205
117	10242	12993	468	702	491	117	178	135	129	219
120	10700	13573	480	720	504	120	182	138	132	241
127	11789	14955	508	762	533	127	193	146	140	280
133	12746	16169	532	798	559	133	202	153	146	322
146	14881	18877	584	876	613	146	222	168	161	425
152	15890	20156	608	912	638	152	231	175	167	480

Tolerances on Forged Surfaces +/- 2.5% - Tolerances on Machined Surfaces + / - 1% - Tolerances on Crown Area +5% / -0%

CROWN ANCHOR SHACKLE

WITH ABS CERTIFICATION

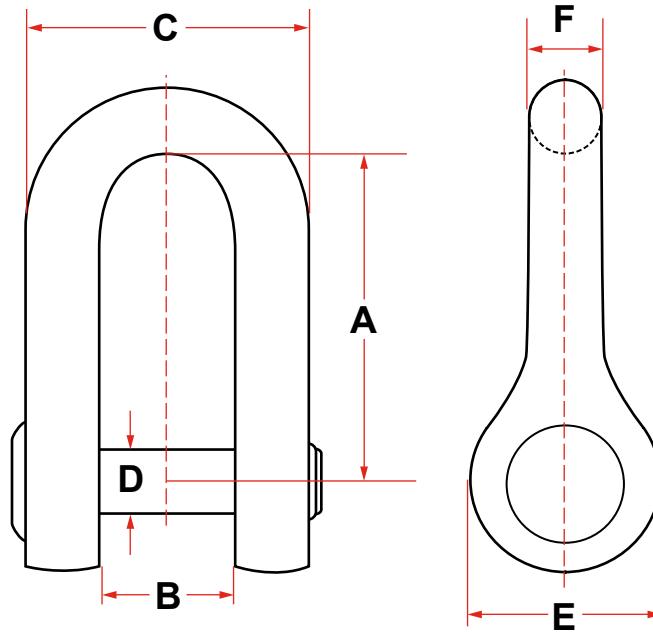

SHACKLE SIZE		A (MM)	B (MM)	C (MM)	D (MM)	E (MM)	F (MM)	WEIGHT		PROOF LOAD (LBS)
MM	INCHES							KG	LBS.	
51	2	254.0	88.9	190.5	50.8	136.0	50.8	20	44	54,500
64	2-1/2	304.8	111.1	238.1	63.5	168.0	63.5	50	110	90,700
76	3	355.6	152	304	76.2	200.0	76.2	80	176	145,000
89	3-1/2	406.4	165.1	342.9	88.9	230.0	88.9	120	265	165,600
102	4	482.6	194.2	387.4	101.6	265.0	101.6	170	375	230,000
114	4-1/2	558.8	203.2	431.8	114.3	300.0	114.3	240	529	282,500

JAW & JAW SWIVEL SHACKLES TYPE A

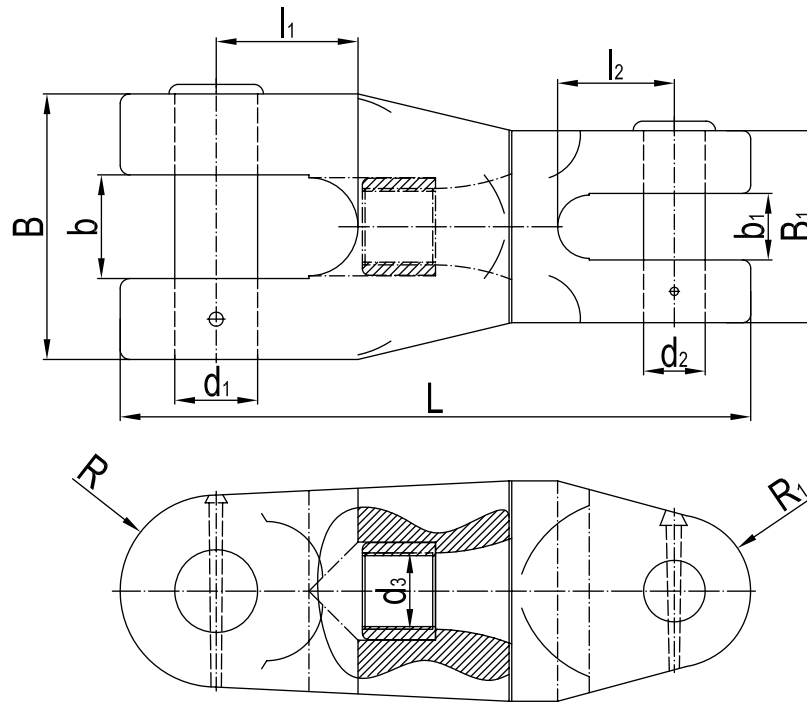

CHAIN NOMINAL SIZE	APPLY SIZE	DIMENSIONS (MM)												WEIGHT (KG)
		L	B	B1	B	B1	R	R1	D3	D1	D2	I1	I2	
24	22,24	307	138	96	80	34	48	38	M36	60	31	70	62	18
28	26,28	372	157	116	84	39	58	47	M42	68	36	87	73	38
32	30,32	423	180	124	96	45	62	53	M52	78	42	101	73	91
38	34,36,38	482	213	148	104	53	74	58	M56	82	49	115	94	107
42	40,42	546	235	164	115	59	82	66	M64	90	55	131	106	115
48	44,46,48	615	269	196	125	67	98	75	M76	98	62	145	118	139
52	50,52	712	314	218	130	73	109	88	M90	107	68	168	135	264
56	54,56	712	314	218	138	78	109	88	M90	110	73	168	135	270
62	58,60,62	787	348	252	149	88	126	100	M100	118	82	185	152	294
68	64,66,68	868	380	265	166	95	136	106	M110	128	88	200	150	403
76	70,73,76	965	426	304	168	106	152	120	M120	135	100	225	184	464
81	78,81	1,042	454	328	178	113	164	130	M130	145	105	240	183	749
87	84,87	1,118	487	352	190	122	176	140	M140	152	113	260	214	931
95	90,92,95	1,206	532	380	200	133	190	152	M150	160	124	280	231	1,191
102	100,102	1,308	571	412	220	143	206	164	M165	168	133	300	253	1,464

D-TYPE ANCHOR SHACKLE

All figures are factors which have to be multiplied with the nominal chain diameter.

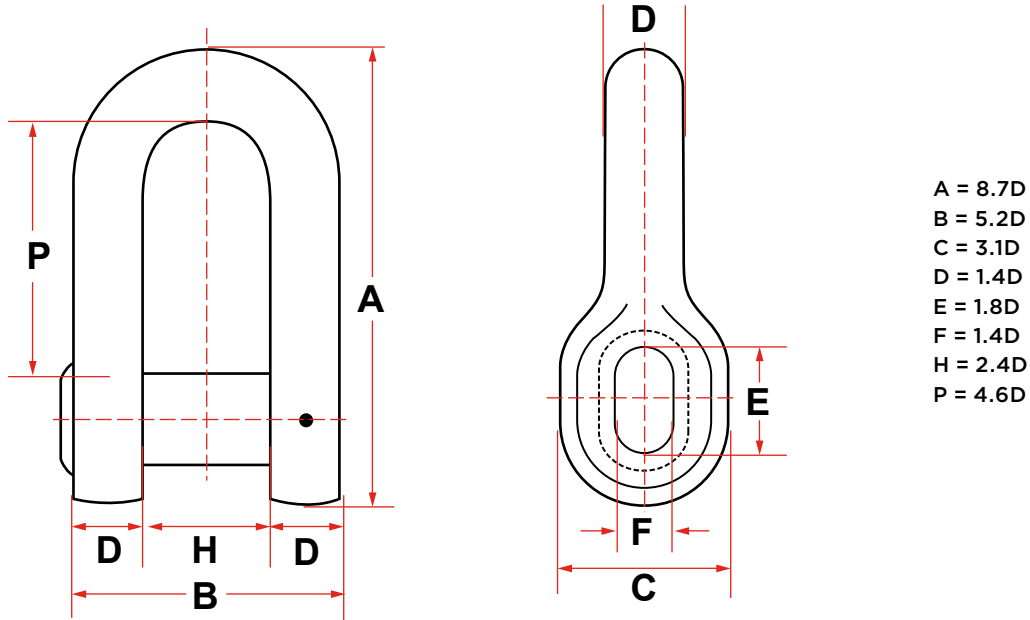

SIZE		DIMENSIONS (INCHES)								WEIGHT	
INCHES	MM	A	B	C	D	E	F	H	P	LBS	KG
3/4	19	6-1/2	3-7/8	2-3/8	1	1-3/8	1	1-3/4	3-1/2	5.5	2.5
7/8	22	7-5/8	4-1/2	2-3/4	1-1/4	1-5/8	1-1/4	2-1/8	4	8.4	3.8
1	25	8-3/4	5-1/4	3-1/8	1-3/8	1-3/4	1-3/8	2-3/8	4-5/8	13.2	6
1-1/8	29	9-3/4	5-7/8	3-1/2	1-5/8	2	1-5/8	2-3/4	5-1/8	18.5	8.4
1-1/4	32	10-7/8	6-1/2	3-7/8	1-3/4	2-1/4	1-3/4	3	5-3/4	24.9	11.3
1-3/8	35	12	7-1/8	4-1/4	1-7/8	2-1/2	1-7/8	3-1/4	6-3/8	34.2	15.5
1-1/2	38	13	7-3/4	4-5/8	2-1/8	2-3/4	2-1/8	3-5/8	6-7/8	43.7	19.8
1-5/8	41	14-1/8	8-1/2	5	2-1/4	2-7/8	2-1/4	3-7/8	7-1/2	56.9	25.8
1-3/4	44	15-1/4	9-1/8	5-3/8	2-1/2	3-1/8	2-1/2	4-1/4	8	70.3	31.9
1-7/8	48	16-3/8	9-3/4	5-7/8	2-5/8	3-3/8	2-5/8	4-1/2	8-5/8	85.5	38.8
2	51	17-3/8	10-3/8	6-1/4	2-3/4	3-5/8	2-3/4	4-3/4	9-1/4	105.8	48
2-1/8	54	18-1/2	11	6-5/8	3	3-7/8	3	5-1/8	9-3/4	125.7	57
2-1/4	57	19-5/8	11-3/4	7	3-1/8	4	3-1/8	5-3/8	10-3/8	147.7	67
2-3/8	60	20-5/8	12-3/8	7-3/8	3-3/8	4-1/4	3-3/8	5-3/4	10-7/8	176.6	80.1
2-1/2	64	21-3/4	13	7-3/4	3-1/2	4-1/2	3-1/2	6	11-1/2	204.1	92.6
2-5/8	67	22-7/8	13-5/8	8-1/8	3-5/8	4-3/4	3-5/8	6-1/4	12-1/8	234.6	106.4
2-3/4	70	23-7/8	14-1/4	8-1/2	3-7/8	5	3-7/8	6-5/8	12-5/8	267.6	121.4
2-7/8	73	25	15	8-7/8	4	5-1/8	4	6-7/8	13-1/4	310.2	140.7
3	76	26-1/8	15-5/8	9-1/4	4-1/4	5-3/8	4-1/4	7-1/4	13-3/4	350.5	159

Approximate dimensions shown. Contact us for specific dimensions, as they may differ between manufacturers.

**76MM PEAR SHAPED RING
 WITH ABS CERTIFICATION**

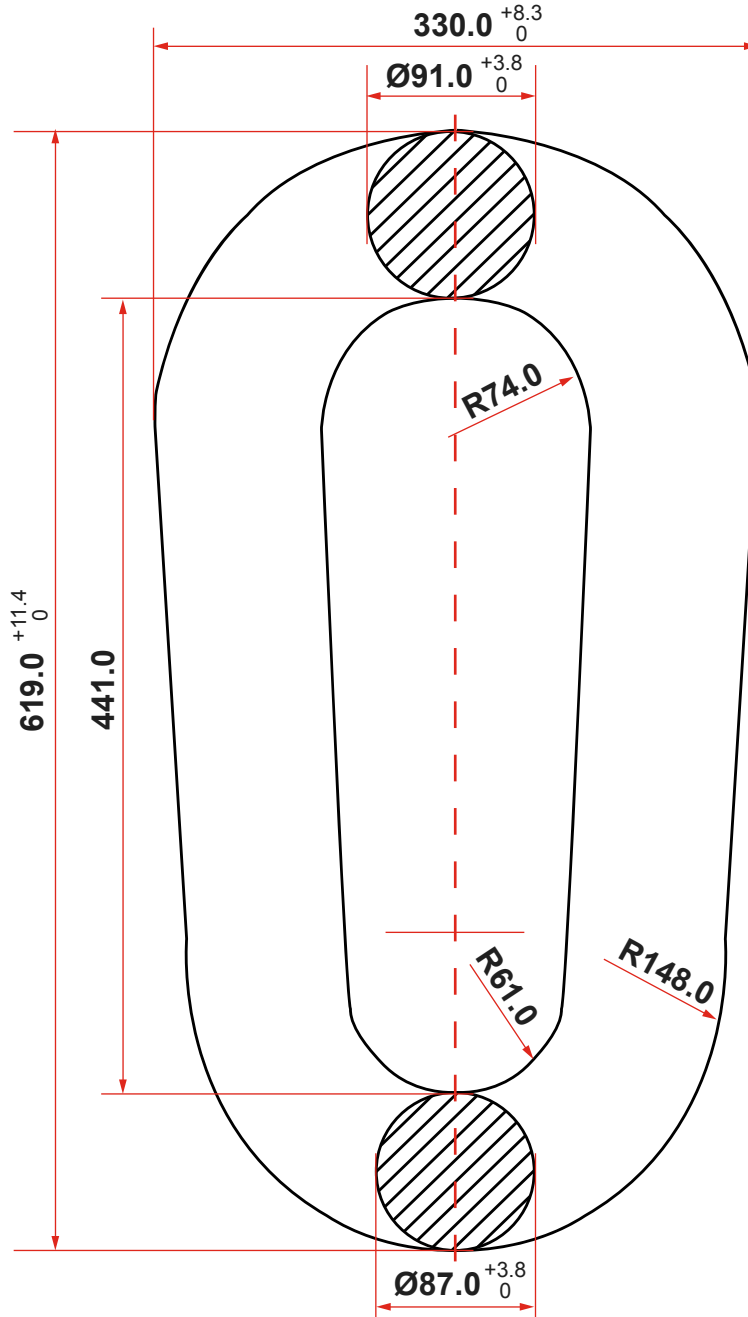

- Notes:
- 1. Weight 160lbs
 - 2. Proof Load 3066.4 kN
 - 3. Break Load 4621.4 kN

PEAR RING

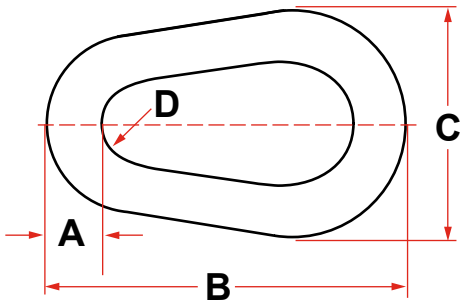

CHAIN SIZE		DIMENSIONS								WEIGHT	
		INCHES				MM					
MM	INCHES	A	B	C	D	A	B	C	D	KG	LBS
42	1-5/8	2.10	8.30	3.90	1.30	53	211	99	33	12	26
44	1-3/4	2.25	11.50	4.19	1.38	57	292	106	35	17	38
51	2	2.50	13.73	4.91	1.64	64	349	125	42	26	57
58	2-1/4	2.75	14.50	5.37	1.73	70	368	136	44	33	73
64	2-1/2	3.00	16.16	5.92	1.92	76	410	150	49	43	95
70	2-3/4	3.50	17.70	6.47	2.11	89	450	164	54	65	143
76	3	3.75	19.21	6.82	2.28	95	488	173	58	80	176
89	3-1/2	4.25	23.90	8.77	2.85	108	607	223	72	127	280
102	4	4.75	26.22	9.61	3.13	121	666	244	80	175	385

END LINK

CHAIN SIZE		DIMENSIONS						WEIGHT	
		INCHES			MM				
MM	INCHES	A	B	C	A	B	C	KG	LBS
42	1-5/8	10.97	6.50	1.95	279	165	50	9	20
44	1-3/4	11.81	6.91	2.10	300	176	53	11	24
51	2	13.50	7.90	2.40	343	201	61	17	37
58	2-1/4	15.19	8.89	2.70	386	226	69	24	53
64	2-1/2	16.88	9.88	3.00	429	251	76	32	71
70	2-3/4	18.56	10.86	3.30	471	276	84	43	95
76	3	20.25	11.85	3.60	514	301	91	55	122
89	3-1/2	23.65	13.83	4.20	601	351	107	90	197
102	4	27.00	15.80	4.80	686	401	122	133	292

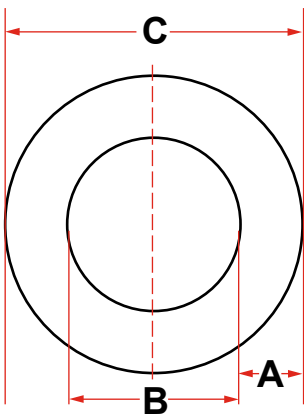
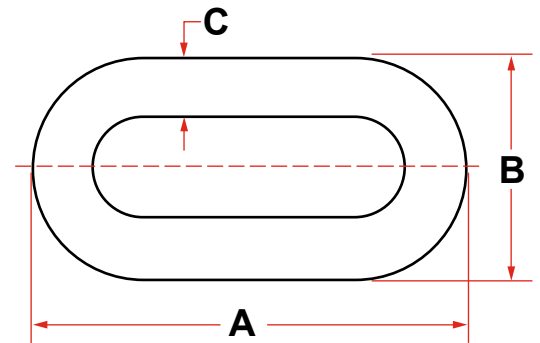

MOORING RING

CHAIN SIZE		DIMENSIONS						WEIGHT		PROOF TEST
		INCHES			MILLIMETERS					
MM	INCHES	A	B	C	A	B	C	LBS	KG	LBS
25	1	2.125	7.2	11.22	54	183	291	26	12	83,600
32	1-1/4	2.5	9.02	14.06	64	229	357	51	23	129,000
38	1-1/2	3	10.79	16.77	76	274	426	86	39	183,500
44	1-3/4	3.5	12.76	19.84	90	324	504	143	65	247,000
51	2	4	14.41	22.44	102	366	570	207	94	318,000
58	2-1/4	4.5	16.18	25.16	114	411	639	291	132	396,000
64	2-1/2	5	17.99	27.99	127	457	711	401	182	484,000
76	3	6	21.57	33.54	152	548	852	688	312	679,000
89	3-1/2	7	25.20	39.21	178	640	996	1107	502	900,000
102	4	8	28.90	44.96	204	734	1142	1664	755	1,143,000

RETRIEVING HARDWARE

CHAIN CHASER AND GRAPNEL

Used in the recovery of anchors and mooring lines, J-type chain chasers, permanent chain chasers, detachable permanent chain chasers, and grapnels are manufactured as one-piece units from special cast steel which is annealed for maximum unit strength.

Retrieving hardware is designed for use with 2-3/4 to 3-1/2 in. mooring chain and anchors in the 30,000 to 45,000-lb. class. All hardware is manufactured with rated testing loads which vary from 150 to 250 tons.

All chasing equipment comes standard with welded hard-facing on contact areas to inhibit wear. Optional treatments include Rapid Solidification Plasma Deposition or R.S.P.D. For superior wear and corrosion resistance isolated areas or entire castings can be treated.

J-TYPE CHAIN CHASER

The J-Type, chain chaser, complete with swivel shackle, is used to retrieve a rig's anchor when the pendant line is broken. It is a highly refined, stronger version of the conventional chain chaser originally developed for use in the North Sea. This unique design uses a sophisticated beam configuration in place of the usual T-type cross section to optimize quality and reliability.

PERMANENT CHAIN CHASER

For rigs requiring a permanent-type chain chaser, it offers a stronger, better engineered version of the conventional chain chaser used in the North Sea. This type of anchor retrieval system eliminates the need for a pendant line buoy system. As with the J-type chaser, the permanent chaser incorporates a beam configuration that lessens the possibility of breaking with a significant decrease in eccentric bending.

DETACHABLE CHAIN CHASER

Engineers have modified the conventional permanent chaser design to make the wear area detachable and replaceable. This innovative design allows the user to hook up easily and replace individual parts that are prone to wear, rather than replacing the entire chain chaser.

GRAPNEL

In order to offer a total coverage for a variety of retrieving applications, we offer a four-prong grapnel. This unit is designed to recover lost anchors and mooring lines. The four-prong grapnel reduces the outfitting costs, since it is designed to accommodate the same connecting hardware as the permanent and J-type chain chasers.

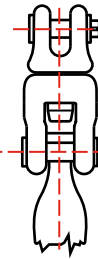

Recommended
Standard Swivel
Shackle

Alternate 3"
Safety-Type
Anchor Shackle

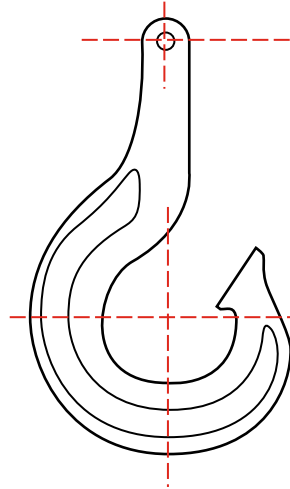

J-TYPE CHAIN CHASER

Notes:

1. Weight - 3,200 lbs. (approx.)
2. Test Load - 250 tons (500,000 lbs.) straight pull

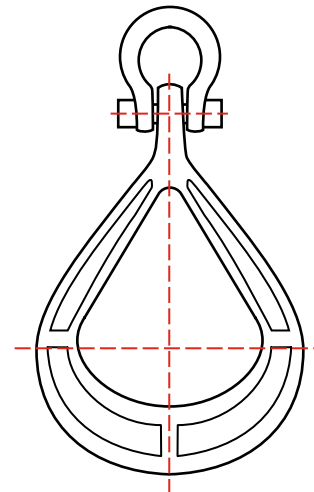

PERMANENT CHAIN CHASER

Notes:

1. Weight - 2,600 lbs. (approx.)
2. Test Load - 250 tons (500,000 lbs.) straight pull

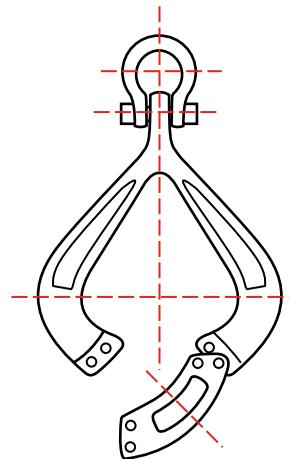

DETACHABLE CHAIN CHASER

Notes:

1. Weight - 2,610 lbs. (approx.)
2. Test load - 250 tons (500,000 lbs.) straight pull
3. Safe Working Load - 110 tons (220,000 lbs.)

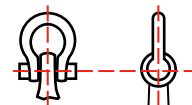

FOUR-PRONG GRAPNEL

Notes:

1. Weight - 4,000 lbs. (approx.)
2. Test Load - 150 tons

PAWL TYPE CHAIN STOPPER

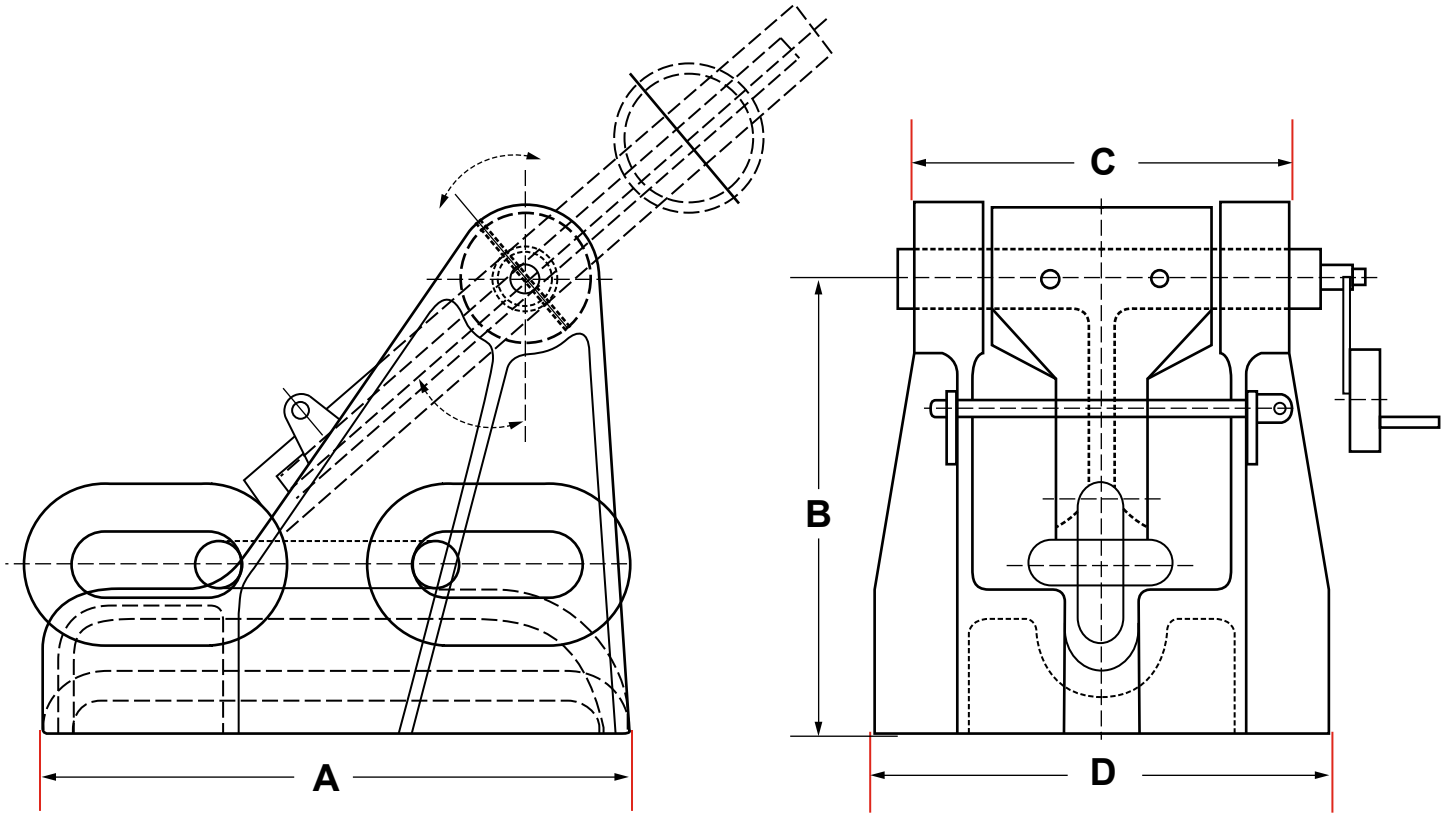

NOMINAL NO.	NOMINAL DIA. OF ANCHOR CHAIN	DIMENSIONS (MM)				WEIGHT (KG.)
		A	B	C	D	
42	36-42	530	494	357	422	210
46	42-46	620	538	404	480	396
51	48-51	680	599	438	520	429
56	52-56	730	638	472	560	465
60	58-60	780	670	506	600	480
64	62-64	835	710	538	630	500
68	66-68	885	750	568	660	567
73	70-73	950	801	604	700	682
78	76-78	1015	852	641	750	818
84	81-84	1095	911	686	800	1030
90	87-90	1170	969	732	850	1220
95	92-95	1235	1021	768	900	1420
102	97, 100, 102	1350	1090	816	950	1830
107	105-107	1400	1148	857	1000	2130
114	111-114	1480	1207	902	1050	2410
122	117-122	1585	1280	956	1120	2900

PELICAN HOOK CHAIN STOPPER WITH ABS CERTIFICATION

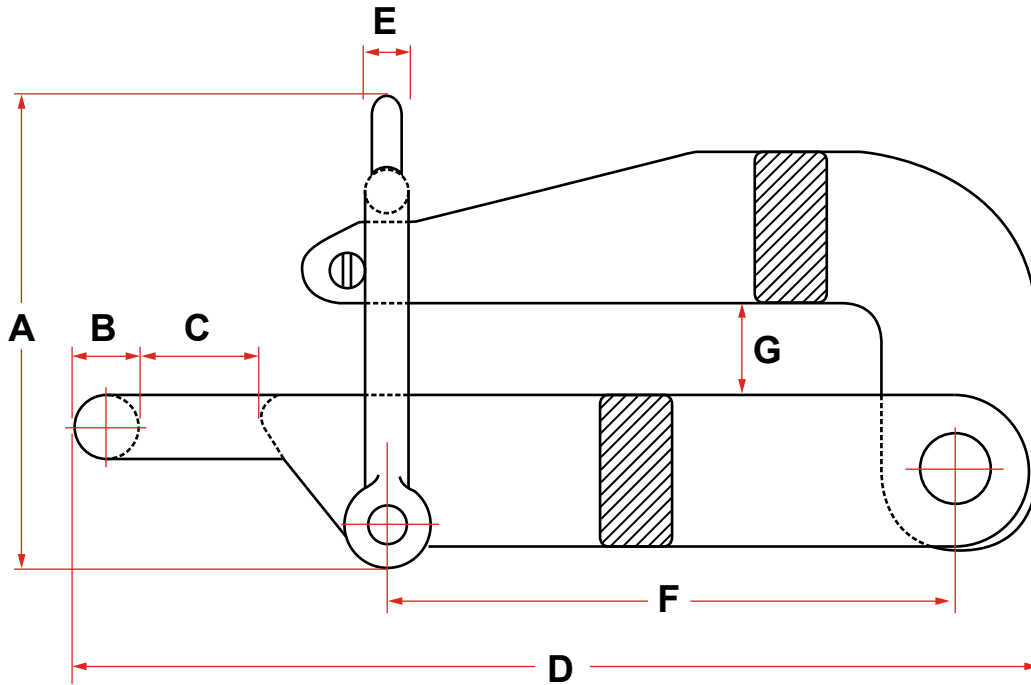

CHAIN SIZE		A	B	C	D	E	F	G	PROOF LOAD	BREAK LOAD	WEIGHT
MM	In	MM	MM	MM	MM	MM	MM	MM	kN	kN	Lbs
19	3/4	176	19	32	266	16	137	25	291.3	388.3	13
22	7/8	193	22	35	337	16	178	31	377.6	509.9	21
25-32	1 - 1-1/4	219	29	41	446	19	260	39	690.4	931.6	41
32-38	1-1/4 - 1-1/2	270	38	48	490	22	267	44	888.5	1,198.9	50
35-41	1-3/8 - 1-5/8	270	38	48	490	22	267	51	941.6	1,271.1	59
41-51	1-5/8 - 2	313	38	54	565	25	305	62	1,057	1,426.9	95
54-60	2-1/8 - 2-3/8	375	41	57	680	32	394	65	1,122	1,514.6	172
64-70	2-1/2 - 2-3/4	410	48	70	780	35	457	79	1,567.2	2,119.3	216
76-83	3 - 3-1/4	454	51	76	860	38	502	95	1,816.5	2,715.9	280
86-89	3-3/8 - 3-1/2	495	64	86	927	41	514	98	2,190.5	3,312.5	357
89-95	3-1/2 - 3-3/4	568	73	108	997	44	533	114	3,137	4,746	440

DEVILS CLAW CHAIN STOPPER

WITH ABS CERTIFICATION

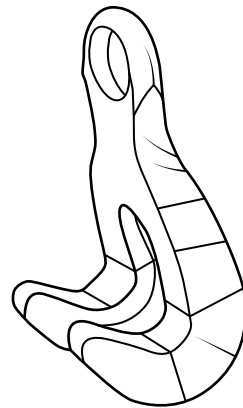
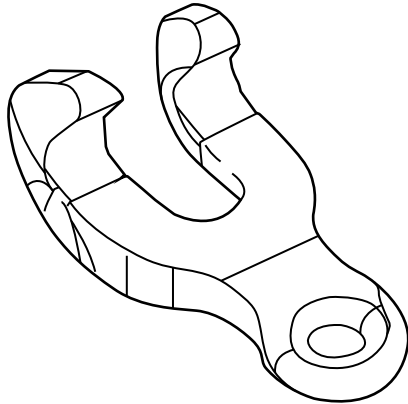

DEVILS CLAW
33 - 41MM (1-5/16" - 1-5/8")
44 LBS

DEVILS CLAW
46 - 60MM (1-11/16" - 2-3/8")
70 LBS

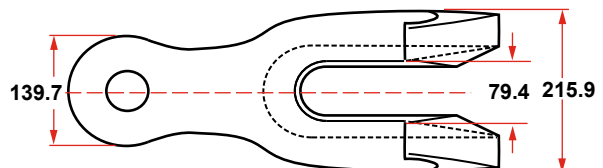
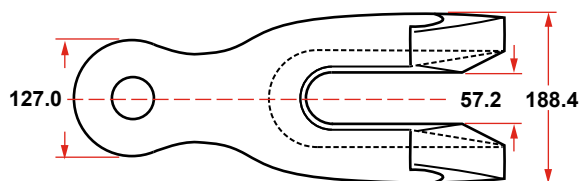
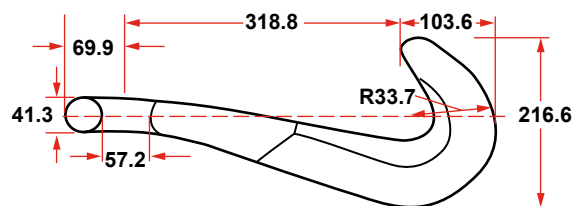
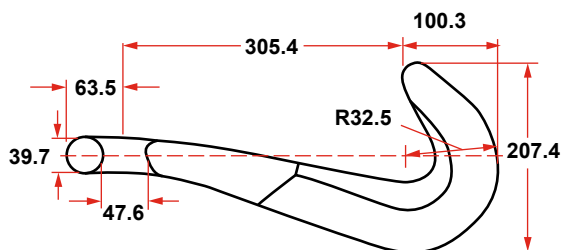

Dimensions in millimeters. Other sizes available upon request.

PELICAN HOOK TYPE CHAIN STOPPER ASSEMBLY

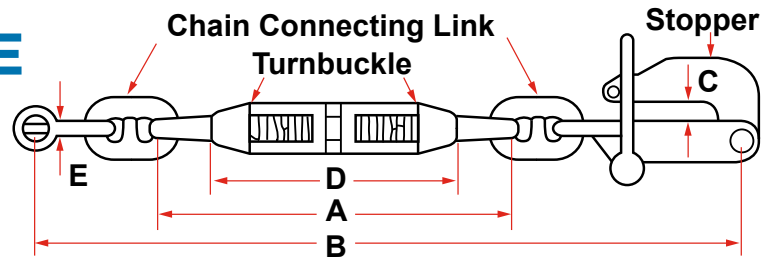

CHAIN SIZE		INCHES						DET. LINK SIZE	PROOF LOAD LBS	BREAK LOAD LBS
INCHES	MM	A	B MIN.	B MAX.	C	D	E			
3/4	19	16	33-1/4	40-1/2	1	11	7/8	3/4	67,500	91,100
7/8	22	17-1/4	38-7/16	45-9/16	1-7/32	11	1	7/8	88,200	119,000
1 - 1-1/8	25 - 29	19-1/2	46-7/8	55-1/2	1-17/32	13	1-1/8	1-1/8	145,000	195,000
1-1/4	32	19-5/8	48	56-5/8	1-17/32	13	1-1/4	1-1/4	178,200	240,600
1-1/4 HS - 1-1/2	32HS - 38	23-3/4	55-3/16	65-11/16	1-3/4	16	1-1/2	1-3/8	211,500	285,500
1-3/8HS - 1-5/8	34HS - 42	23-3/4	55-3/16	65-11/16	2	16	1-1/2	1-3/8	211,500	285,500
1-5/8HS - 2	42HS - 51	24-1/8	59-3/16	65-11/16	2-7/16	16	1-1/2	1-1/2	252,000	340,200
2-1/8 - 2-3/8	54 - 60	26-1/4	65-3/8	76-1/8	2-9/16	16	1-5/8	1-1/2	252,000	340,200
2-1/2 - 2-5/8	64 - 67	29-3/4	74-3/8	87-1/2	3-1/8	20	1-7/8	1-5/8	292,500	395,000
2-3/4 - 2-3/4HD	70 - 70HD	29-3/4	86-5/8	89-3/4	3-1/8	20	1-7/8	1-3/4	352,000	476,000
3HD - 3-1/4	76HD - 83	36	90-3/4	106-1/2	3-3/4	24	2-3/8	2-1/4	403,000	610,000
3-3/8 - 3-1/2	86 - 89	38-5/8	97-7/16	113-3/16	3-7/8	24	2-5/8	2-1/2	492,000	744,000
3-1/2HD - 3-3/4	89HD - 95	44-3/8	110	128-1/8	4-1/2	27-1/2	2-7/8	3	706,000	1,068,000

DEVIL'S CLAW TYPE CHAIN STOPPER ASSEMBLY

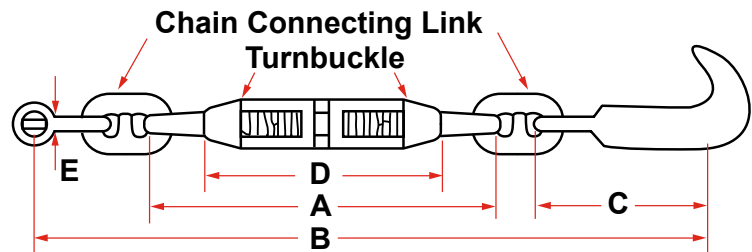

CHAIN SIZE		INCHES						DET. LINK SIZE	PROOF LOAD LBS	BREAK LOAD LBS
INCHES	MM	A	B MIN.	B MAX.	C	D	E			
3/4 - 3/4HS	19 - 19HS	16	35-1/2	42-3/4	10-1/2	11	7/8	3/4	67,500	91,100
7/8 - 7/8HS	22 - 22HS	17-1/4	38-1/4	45-3/8	10-1/2	11	1	7/8	88,200	119,000
1 - 1-1/8	25 - 29	19-1/2	43-1/16	51-11/16	10-1/2	13	1-1/8	1-1/8	145,000	195,000
1-1/4	32	19-5/8	44-3/16	52-13/16	10-1/2	13	1-1/4	1-1/4	178,200	240,600
1-1/4 HS - 1-1/2	32HS - 38	23-3/4	50-1/4	60-3/4	10-1/2	16	1-1/2	1-3/8	211,500	285,500
1-3/8HS - 1-5/8	34HS - 42	23-3/4	50-1/4	60-3/4	10-1/2	16	1-1/2	1-3/8	211,500	285,500
1-5/8HS - 2	42HS - 51	24-1/8	53-1/8	63-5/8	12	16	1-1/2	1-1/2	252,000	340,200
2-1/8 - 2-3/8	54 - 60	26-1/4	56-1/4	66-3/4	12-1/2	16	1-5/8	1-1/2	252,000	340,200
2-1/2 - 2-5/8	64 - 67	29-3/4	65	78-1/8	16	20	1-7/8	1-5/8	292,500	395,000
2-3/4 - 2-3/4HD	70 - 70HD	29-3/4	67-1/4	80-1/4	16	20	1-7/8	1-3/4	352,000	476,000
3HD - 3-1/4	76HD - 83	36	76-1/4	92-3/8	17-1/2	24	2-3/8	2-1/4	403,000	610,000
3-3/8 - 3-1/2	86 - 89	38-5/8	86-1/2	102-1/4	19	24	2-5/8	2-1/2	492,000	744,000
3-1/2HD - 3-3/4	89HD - 95	44-3/8	98-5/8	116-3/4	20-1/2	27-1/2	2-7/8	3	706,000	1,068,000

DETACHABLE LINK PUNCHES

These punches are designed for the assembly and disassembly of detachable chain connecting links, kenter links, and anchor joining links. Sizes will vary for kenters and pear links made from steel, heat treated to 45-50 Rockwell C.

ASSEMBLING PUNCHES

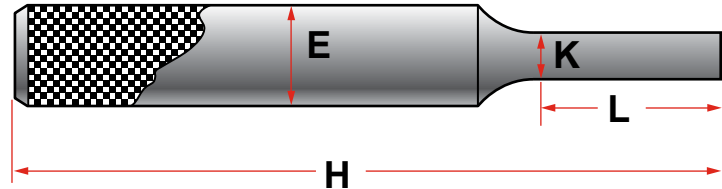

PUNCH NO.	INCHES					HANDLE
	LINK SIZE	E	K	H	L	
P-1A	5/8 - 3/4	3/4	15/64	5	1-1/8	
P-2A	7/8 - 1	3/4	17/64	5	1-1/8	
P-3A	1-1/8 - 1-3/8	1	3/8	6	1-3/8	
P-4A	1-1/2 - 1-5/8	1	33/64	6-1/2	1-3/8	
P-5A	1-3/4 - 2	1	21/32	6-1/2	1-1/2	X
P-6A	2-1/8 - 2-3/8	1	51/64	6-1/2	1-5/8	X
P-7A	2-1/2 - 2-7/8	1-1/8	61/64	6-1/2	1-5/8	X
P-8A	3	1-1/4	1-9/64	7	1-3/4	X

DISASSEMBLY PUNCHES

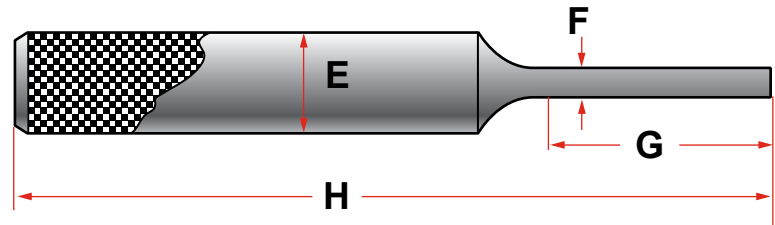

PUNCH NO.	INCHES					HANDLE
	LINK SIZE	E	F	H	G	
P-1D	5/8 - 3/4	3/4	13/64	5	1-1/4	
P-2D	7/8 - 1	3/4	15/64	5	1-1/2	
P-3D	1-1/8 - 1-3/8	1	5/16	6	2-1/2	
P-4D	1-1/2 - 1-5/8	1	15/32	6-1/2	2-7/8	
P-5D	1-3/4 - 2	1	9/16	6-1/2	3-1/4	X
P-6D	2-1/8 - 2-3/8	1	11/16	6-1/2	3-1/2	X
P-7D	2-1/2 - 2-7/8	1-1/8	13/16	6-1/2	3-1/2	X
P-8D	3	1-1/4	1	7	4	X

CORDAGE



THREE STRAND & EIGHT STRAND - STANDARD LAY ROPES

SPECIFICATIONS



MARINE LINES



INDUSTRIAL LINES



FISHING LINES

SIZE (INCHES)		POLYPRO		NYLON		COMBO		MANILA		WORKING LOADS
DIA.	CIRC.	MIN. TENSILE STRENGTH	LBS. PER 600 FT.	MIN. TENSILE STRENGTH	LBS. PER 600 FT.	MIN. TENSILE STRENGTH	LBS. PER 600 FT.	MIN. TENSILE STRENGTH	LBS. PER 600 FT.	SPLICED WORKING LOAD RATIO
3/16"	5/8"	650	4	880	6	-	-	405	9	10.1
1/4"	3/4"	1,125	7	1,468	9	1,200	10	540	12	10.1
5/16"	1"	1,710	11	2,295	15	1,870	15	900	17	10.1
3/8"	1 1/8"	2,430	17	3,240	21	2,700	22	1,215	25	10.1
7/16"	1 1/4"	3,150	23	4,320	30	3,500	28.8	1,575	32	10.1
1/2"	1 1/2"	3,780	28	5,670	39	4,400	39	2,385	45	9.1
9/16"	1 3/4"	4,590	37	7,200	50	5,200	46	3,105	62	8.1
5/8"	2"	5,580	45	8,910	63	6,100	55	3,960	80	8.1
3/4"	2 1/4"	7,650	64	12,780	87	8,400	75	4,860	100	7.1
13/16"	2 1/2"	9,900	76	17,000	102	11,200	88	5,850	117	7.1
7/8"	2 3/4"	10,350	90	17,280	120	11,125	105	6,930	135	7.1
1"	3"	12,825	108	22,230	156	13,175	131	8,100	162	7.1
1 1/16"	3 1/4"	14,400	122	25,200	174	14,775	147	9,450	187	7.1
1 1/8"	3 1/2"	16,000	143	28,260	204	16,325	165	10,800	216	7.1
1 1/4"	3 3/4"	19,350	162	34,830	240	19,900	198	12,150	251	7.1
1 5/16"	4"	21,150	182	38,250	270	21,950	222	13,500	287	7.1
1 1/2"	4 1/2"	27,350	231	48,600	330	28,250	276	16,650	360	7.1
1 5/8"	5"	31,950	286	57,375	399	32,950	336	20,250	446	7.1
1 3/4"	5 1/2"	36,900	342	66,150	498	36,850	408	23,850	537	7.1
2"	6"	46,800	414	84,600	570	48,050	468	27,900	648	7.1
2 1/8"	6 1/2"	52,650	480	95,400	654	53,950	582	-	-	7.1
2 1/4"	7"	59,400	552	107,100	774	59,950	648	-	-	6.1
2 1/2"	7 1/2"	72,000	642	131,400	894	73,550	732	-	-	6.1
2 5/8"	8"	80,500	720	144,000	1,008	80,650	828	-	-	6.1
2 3/4"	8 1/2"	94,500	822	171,000	1,134	95,400	930	-	-	6.1
3"	9"	102,600	918	185,400	1,260	102,900	1,074	57,500	1,380	6.1
3 1/4"	10"	121,500	1,140	224,100	1,584	122,800	1,290	-	-	6.1
3 1/2"	11"	144,000	1,392	267,300	1,872	144,800	1,488	-	-	6.1
4"	12"	171,900	1,656	324,000	2,280	171,000	1,740	-	-	6.1
4 1/4"	13"	198,000	1,920	369,000	2,580	195,800	2,310	-	-	6.1
4 5/8"	14"	252,000	2,190	510,000	3,000	224,800	2,682	-	-	6.1
5"	15"	256,500	2,520	570,000	3,420	254,700	3,078	-	-	6.1

The information contained herein is descriptive only and is presented without warranty. These specifications are the result of tests made on new and unused rope of current manufacture in accordance with the Cordage Institute Standard Test Methods. They do not cover exceptional conditions such as shock load, sustained load, etc. Pounds per 100 feet are "average" for synthetics. The maximum weight is 5% above these figures. Manila approximately 95% of the strength of three standard Manila size for size. Specifications for other ropes, are available on request.

SIZE (INCHES)		APPROX. AVERAGE TENSILE STRENGTH (LBS.)	NET WEIGHT * PER 100 FT. IN POUNDS
DIAMETER	CIRCUMFERENCE		
3/8	1-1/8	4300	3.5
7/16	1-1/4	6000	5.0
1/2	1-1/2	8000	6.7
9/16	1-3/4	10000	8.3
5/8	2	13000	10.5
3/4	2-1/4	16500	14.5
7/8	2-3/4	24500	20.8
1	3	29000	25.8
1-1/16	3-1/4	35000	31.0
1-1/8	3-1/2	39000	35.0
1-1/4	3-3/4	44000	40.0
1-5/16	4	49000	45.0
1-1/2	4-1/2	61500	62.5

DOUBLE-BRAID NYLON

This line is produced from 100% white nylon fibers in both the cover and core. In commercial fishing, Double-Braid Nylon is recommended for use as Towing Lines, Brailing Lines, Double and Single Falls, and for general all-purpose uses. For pleasure boating uses these ropes are excellent Mooring and Anchor Lines. In the utility industry they are used as Hand Lines and Bull Ropes. Double Braid Nylon is fully spliceable. Subject to +10%, -0% from these figures.

SIZE (INCHES)		APPROX. AVERAGE TENSILE STRENGTH (LBS.)	NET WEIGHT * PER 100 FT. IN POUNDS
DIAMETER	CIRCUMFERENCE.		
3/8	1-1/8	4300	4.5
7/16	1-1/4	6000	6.2
1/2	1-1/2	8000	8.0
9/16	1-3/4	10000	10.5
5/8	2	13000	13.0
3/4	2-1/4	16500	17.5
7/8	2-3/4	24500	25.0
1	3	29000	30.5
1-1/16	3-1/4	35000	36.0
1-1/8	3-1/2	39000	40.0
1-1/4	3-3/4	44000	47.0
1-5/16	4	49000	53.0
1-1/2	4-1/2	61500	67.0

DOUBLE-BRAID POLYESTER

A line incorporating 100% polyester fibers in both the cover and the core. Double-Braid Polyester is the answer to rugged demands requiring a rope with high strength and low stretch. In the utility field this product has received excellent reception in overhead transmission work for pulling in new and replacement conductors. It is also replacing wire as a Winch Line. Commercial fishermen request it for Purse Lines. Sailing enthusiasts require it for all running rigging. Industry uses it for fabricating rope sling. As with other Double-Braid products, it is fully spliceable. *Subject to +10%, -0% from these figures.



MANILA SAFETY LINE SPECIFICATIONS

DIAMETER SIZE (INCHES)	WEIGHT PER 100 FT (LBS.)	MINIMUM BREAKING STRENGTH (LBS.)
7/8	26.5	2700

MANILA SAFETY LINE is engineered for the job. It is a safety line used by tree toppers in lumbering, by high scalers in dam building and construction, and wherever there is an unusual hazard of damage to climbing rope. A BUILT-IN EXTRA MARGIN OF SAFETY makes it very different from regular manila rope. Not only is it a four-strand product, but in the center of the rope there is a heart of wire rope (performed super steel). If the Manila rope is accidentally damaged, the wire adds the margin of safety for the protection of life and limb.

PLASMA® 12 STRAND

Plasma™ 12 strand is the highest strength synthetic rope available. Plasma™ 12 strand is manufactured from AlliedSignal Spectra® Fiber that has been enhanced by Puget Sound Rope's patented recrystallization process. This process is especially effective in medium to large diameter ropes where strengths are over 50% higher and creep is significantly less than that of standard Spectra® 12 strand.

Plasma™ 12 strand comes standard with a polyurethane finish and is easily spliced using a simple lockstitch type splice or 4-3-2 tuck splice. Its soft, torque free braided construction provides easy handling.

Tensile Strengths are determined in accordance with ASTM test method D 4268-83.

Weights are calculated at linear density under standard preload (200 d²) plus 4%.

Highest strength
Lowest stretch
Low creep
Soft hand
Torque free
Easy splicing
Floats

Specify gravity.....	0.98
Melting point.....	284° F
Critical temp.....	150° F
Coefficient of friction.....	0.09-0.12
Elongation at break.....	4% - 5%
Fiber water absorption.....	0%
UV resistance.....	excellent
Wet abrasion.....	superior
Dry abrasion.....	superior

SPECTRA® 12 STRAND

Spectra® 12 strand provides very high strength, low stretch and excellent abrasion resistance in a single braid construction.

For the equivalent weight rope it is over 3 times as strong as polyester and has less than one half the elongation.

Spectra® 12 strand comes standard with a polyurethane finish and is easily spliced using a 4-3-2 tuck splice. Its soft, torque free braided constructions provides easy handling.

Tensile Strengths are determined in accordance with ASTM test method 4268-83.

Weights are calculated using the linear density under standard preload (200 d²) plus 4%.

Very Low stretch
Very High strength
Soft hand
Torque free
Easy splicing
Floats

Specify gravity.....	0.98
Melting point.....	284° F
Critical temp.....	150° F
Coefficient of friction.....	0.09-0.12
Elongation at break.....	6% - 8%
Fiber water absorption.....	0%
UV resistance.....	excellent
Wet abrasion.....	superior
Dry abrasion.....	superior

NOMINAL DIAMETER (INCHES)	SIZE NUMBER (CIRC.)	APPROXIMATE WEIGHT (LBS./100FT.)	MINIMUM TENSILE STRENGTH (LBS.)
7/16	1-1/4	4.2	21000
1/2	1-1/2	6.4	31300
9/16	1-3/4	7.9	37900
5/8	2	10.6	51400
3/4	2-1/4	13.3	68500
7/8	2-3/4	19.6	92600
1	3	23.4	110000
1-1/8	3-1/2	31.9	147000
1-1/4	3-3/4	36.2	165000
1-5/16	4	41.7	196000
1-1/2	4-1/2	51.7	221000
1-5/8	5	65.7	291000
1-3/4	5-1/2	78.4	314000
2	6	91.4	355000
2-1/8	6-1/2	109.0	428000
2-1/4	7	122.0	481000
2-5/8	8	167.0	560000
3	9	214.0	780000
3-1/4	10	261.0	1000000
3-5/8	11	324.0	1250000
4	12	394.0	1520000

NOMINAL DIAMETER (INCHES)	SIZE NUMBER (CIRC.)	APPROXIMATE WEIGHT (LBS./100FT.)	MINIMUM TENSILE STRENGTH (LBS.)
7/16	1-1/4	4.2	14800
1/2	1-1/2	6.4	22500
9/16	1-3/4	7.9	27700
5/8	2	10.6	36600
3/4	2-1/4	13.3	43200
7/8	2-3/4	19.6	61000
1	3	23.4	72000
1-1/8	3-1/2	31.9	91800
1-1/4	3-3/4	36.2	102600
1-5/16	4	41.7	114300
1-1/2	4-1/2	51.7	141300
1-5/8	5	65.7	167400
1-3/4	5-1/2	78.4	198000
2	6	91.4	225000
2-1/8	6-1/2	109.0	270000
2-1/4	7	122.0	317700
2-1/2	7-1/2	148.0	360000
2-5/8	8	167.0	370800
2-3/4	8-1/2	187.0	405000
3	9	214.0	508500
3-1/4	10	261.0	616500
3-5/8	11	324.0	765000
4	12	394.0	900000

* Plasma is a trademark of Puget Sound Rope Corp.

* Spectra is a trademark of Allied Signal Corp.

POLYESTER 12 PLAIT

Polyester 12 Plait provides high strength, low stretch and excellent abrasion resistance in a unique single braid construction.

Polyester 12 Plait is easily spliced using a standard tuck splice and is 30% stronger than three strand or 8 plait polyester. It's torque free braided construction provides easy handling and prevents kinks and hockles.

Polyester 12 Plait comes standard with an overlay marine finish and is available on special order with a spliceable polyurethane finish in clear or any of six colors.

Tensile Strengths are determined in accordance with ASTM test Method D 4268-83.

Weights are calculated at linear density under standard preload (200 d²) plus 5%.

- Low Stretch
- High Strength
- Soft hand
- Torque free
- Easy splicing
- Meets MIL-R-24750

Specify gravity.....	1.38
Melting point.....	482° F
Critical temp.....	350° F
Coefficient of friction.....	0.12-0.15
Elongation at break.....	15% - 20%
Fiber water absorption.....	0% - 1%
UV resistance.....	excellent
Wet abrasion.....	excellent
Dry abrasion.....	excellent

NOMINAL DIAMETER (INCHES)	SIZE NUMBER (CIRC.)	APPROXIMATE WEIGHT (LBS./100FT.)	MINIMUM TENSILE STRENGTH (LBS.)
5/8	2	14.1	12100
3/4	2-1/4	18.7	15800
7/8	2-3/4	28.2	24200
1	3	35.1	27500
1-1/8	3-1/2	41.2	35500
1-1/4	3-3/4	45.9	42100
1-5/16	4	55.0	48200
1-1/2	4-1/2	71.1	59600
1-5/8	5	84.8	72200
1-3/4	5-1/2	98.6	84400
2	6	120.0	101000
2-1/8	6-1/2	141.0	119000
2-1/4	7	160.0	137000
2-1/2	7-1/2	189.0	163000
2-5/8	8	208.0	179000
2-3/4	8-1/2	234.0	202000
3	9	273.0	233000
3-1/4	10	338.0	282000
3-5/8	11	402.0	340000
4	12	486.0	409000

NYLON DOUBLE BRAID

Nylon Double Braid is the preferred choice for applications requiring high strength with excellent shock absorbing properties. Nylon Double Braid has good resistance to abrasion, unlight and chemicals. Due to its high elongation, nylon is almost always used in applications involving shock loading such as anchor lines and mooring lines.

Nylon Double Braid comes standard with an overlay marine finish and is available on special order with a spliceable polyurethane finish in clear or any of six colors.

- High Stretch
- High Strength
- Excellent shock absorption
- Soft hand
- Torque free
- Meets MIL-R-24050D

Specify gravity.....	1.14
Melting point.....	414° F
Critical temp.....	300° F
Coefficient of friction.....	0.12-.015
Elongation at break.....	30% - 35%
Fiber water absorption.....	3% - 5%
UV resistance.....	good
Wet abrasion.....	excellent
Dry abrasion.....	excellent

SIZE (INCHES)		AVG. LBS./100FT.	STRENGTH	STANDARD PACKAGING		
DIAMETER	CIRC.			LENGTH	BULK CARTON APPROX. WT.	600 FT. SPOOL APPROX. WT.
5/8	2	12	14800	4800	576	72
3/4	2-1/4	15	19000	3600	540	90
7/8	2-3/4	22	28300	2400	528	132
1	3	26	33500	2400	624	156
1-1/8	3-1/2	36	44900	1800	648	216
1-1/4	3-3/4	41	52300	1200	492	246
1-5/16	4	47	58800	1200	564	282
1-1/2	4-1/2	60	74000	600	360	360
1-5/8	5	74	92400	600	444	444
1-3/4	5-1/2	89	110900	600	534	534
2	6	106	131500	600	636	636
2-1/8	6-1/2	124	152800			744
2-1/4	7	144	177000			864
2-1/2	7-1/2	165	201000			990
2-5/8	8	188	231000			1128
2-3/4	8-1/2	212	254000			1272
3	9	238	283000			1428
3-1/4	10	294	319000			1764
3-5/8	11	356	381000			2136
4	12	423	447000			2538
4-1/4	13	497	522000			2982

DANLINE/MOORING LINES

8-STRAND, POLYPROPYLENE - BLUE

FEATURES

Low cost general purpose rope that floats and does not absorb water.
Specific Gravity 0.91.

APPLICATIONS

General Marine, Mooring, Tie-Up Lines, Towing and Barge Lines.

DIAMETER (INCHES)	CIRCUMFERENCE (INCHES)	WEIGHT PER 100 FEET (POUNDS)	BREAKING STRENGTH (POUNDS)	COIL LENGTH (FEET)
1-5/8	5	41	43,477	220
2	6	71	63,580	220
2-1/4	7	59.47	73,865	220
2-1/2	7-1/2	69.60	85,085	220
2-5/8	8	105.94	97,240	220
3	9	157	126,310	220
3-1/4	10	190	158,000	220
4	12	280	233,750	220

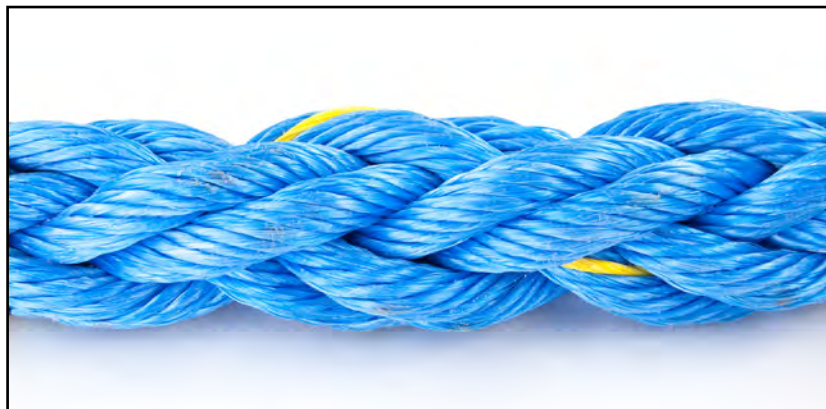

Color: Blue with Yellow Tracer

MAXIFLEX

8-STRAND, POLYESTER/POLYOLEFIN

FEATURES

- We hereby confirm that our Maxiflex Ropes are made as per OCIMF Guidelines x2000.
- With 6' canvas covered eyes

APPLICATIONS

General Marine, Mooring, Tie-Up Lines, Towing and Barge Lines.

1. Review of Rope Design Specification, Material Specification and Manufacturing Specification.
2. Observing and inspecting the yarn/rope through all stages of manufacture and testing.
3. Random witnessing of yarn twisting and rope through all stages of manufacturing machinery set-ups for the above sizes and production thereof.
4. Witnessing the following tests as required by OMIMF Guidelines 1th edition 2000:
 - a. New Dry and New Wet Break Strength Tests.
 - b. Cyclic Load Tests (as applicable)
 - c. Elongation and Extension Measurements, with respect to the rope, for both Dry & Wet conditions.
5. Review and Endorsement of all Manufacturing & Test Data.

MAXIFLEX (CIR)	DIAMETER (INCHES)	TENSILE (LBS)	WEIGHT IN LBS
5" X 720'	1-5/8	66,000	430
6" X 720'	2	101,000	621
7" X 720'	2-1/4	138,000	832
7-1/2" X 720'	2-1/2	158,000	984
8" X 720'	2-5/8	182,133	1,090
9" X 720'	3	224,910	1,380
10" X 720'	3-1/4	276,727	1,705
12" X 720'	4	407,000	2,900



Color: White with Red Tracer

AMSTEEL-BLUE

FEATURES

Uses Dyneema® SK-75
 A size-for-size strength replacement for wire rope at only 1/7th the weight
 Torque-free, very flexible, easy to handle
 Similar elastic elongation to wire rope
 Easily inspected or field spliced
 Floats

APPLICATIONS

- Winch lines, pull-in lines
- Heavy lifting slings
- Primary vessel mooring lines
- Emergency and seismic tow lines
- Rig tow lines
- Grommets

SPECIFICATIONS

- Specific Gravity: .98 (floats)
- Elastic Elongation Percentage:
 At % of break strength

10%	0.46%
20%	0.70%
30%	0.96%

DIAMETER (INCHES)	SIZE CIRCUMFERENCE (INCHES)	WEIGHT PER 100 FT. (LBS.)	SRT MBS* (LBS.)	SIZE DIAMETER (MM)	WEIGHT PER 100 M (KILOGRAMS)	SRT MBS* (METRIC TONS)	ISO/BS EN919 MBS (METRIC TONS)
3/16	9/16	1.0	4,900	5	1.5	2.2	2.4
1/4	3/4	1.6	7,700	6	2.4	3.5	3.9
5/16	1	2.7	12,300	8	4.0	5.6	6.2
3/8	1-1/8	3.6	17,600	9	5.4	8.0	8.9
7/16	1-1/4	4.2	21,500	11	6.2	9.8	10.8
1/2	1-1/2	6.4	30,600	12	9.5	13.9	15.4
9/16	1-3/4	7.9	36,500	14	11.8	16.5	18.4
5/8	2	10.2	47,500	16	15.2	21.5	23.9
3/4	2-1/4	13.3	58,000	18	19.8	26.3	29.2
7/8	2-3/4	19.6	81,700	22	29.2	37.1	41.2
1	3	21.8	98,100	24	32.4	44.5	49.4
1-1/16	3-1/4	27.5	118,000	26	40.9	53.6	59.6
1-1/8	3-1/2	31.9	133,000	28	47.5	60.4	67.1
1-1/4	3-3/4	36.2	149,000	30	53.9	67.5	75.0
1-5/16	4	41.8	166,000	32	62.2	75.2	83.6
1-3/8	4-1/8	45.0	185,000	34	67.0	83.9	93.2
1-1/2	4-1/2	51.7	205,000	36	76.9	93.0	103.0
1-5/8	5	65.2	255,000	40	97.0	116.0	128.0
1-3/4	5-1/2	78.4	302,000	44	117.0	137.0	152.0
2	6	87.0	343,000	48	129.0	155.0	173.0
1-1/8	6-1/2	109.0	411,000	52	162.0	186.0	207.0
2-1/4	7	116.0	484,000	56	173.0	219.0	244.0
2-1/2	7-1/2	148.0	529,000	60	220.0	240.0	267.0
2-5/8	8	167.0	595,000	64	248.0	270.0	300.0
2-3/4	8-1/2	187.0	662,000	68	278.0	300.0	333.0
3	9	206.0	748,000	72	307.0	339.0	377.0
3-1/4	10	240.0	906,000	80	357.0	411.0	457.0
3-5/8	11	340.0	1,313,000	88	506.0	596.0	662.0
4	12	380.0	1,637,000	96	566.0	743.0	825.0
4-1/4	13	430.0	1,826,000	104	640.0	828.0	920.0
4-5/8	14	525.0	2,216,000	112	781.0	1005.0	1117.0
5	15	580.0	2,421,000	120	863.0	1098.0	1220.0
5-1/4	16	635.0	2,637,000	128	945.0	1196.0	1329.0
5-1/2	17	695.0	2,865,000	136	1034.0	1300.0	1444.0
6	18	780.0	3,211,000	144	1161.0	1457.0	1618.0
6-1/4	19	880.0	3,581,000	158	1310.0	1624.0	1805.0
6-5/8	20	1015.0	4,104,000	168	1511.0	1862.0	2068.0
7	21	1090.0	4,370,000	178	1622.0	1982.0	2203.0
7-1/4	22	1170.0	4,658,000	184	1741.0	2113.0	2348.0
7-5/8	23	1325.0	5,243,000	194	1972.0	2378.0	2642.0
8	24	1400.0	5,540,000	203	2084.0	2513.0	2792.0

TYPES OF ROPES

TWISTED. All Cordage products are available in the standard three-strand twisted construction. Some specialty items of Manila rope are manufactured in a four-strand construction.



BRAIDED. Double-Braid was designed and engineered for advantageous use in the power companies and with the electrical contractors; on commercial fishing vessels; on pleasure crafts and in several industries. The Double-Braid construction is available in 100 percent Nylon, and 100 percent Polyester.



PLAITED. These unique hawsers are manufactured in eight-strand construction, having four left laid strands and four right laid strands, paired off, laid parallel and woven together. Plaited lines eliminate hidden stresses arising from kinking and hockling since they will not hockle. The vary nature of this construction is torque free and offers extreme flexibility wet or dry. Plaited ropes are available in 5" circumference and larger.



PROPERTIES OF ROPE	MANILA	NYLON	POLYESTER	POLYPROPYLENE
Strength: Tenacity of dry fiber (in grams/denier):	5-6.0	9.0	8.5	6.5
Suggested maximum rope working load (percentage of Breaking Test):	Varies by diameter size (7% - 10%)	Varies by diameter size (9% - 12%)	Varies by diameter size (7% - 10%)	Varies by diameter size (7% - 10%)
Wet Strength compared to Dry Strength	up to 120%	85-90%	100%	100%
Rope shock absorption ability:	Poor	Excellent	Good	Very Good
Weight: Specific gravity of fibers or filaments:	1.20	1.14	1.38	0.91
Ability to float:	No	No	No	Yes
ROPE STRENGTH/WEIGHT ROTATION (AVG.)	1.0	3.0	2.25	2.5
Elongation: Rope elongation at suggested max. working load.	Low	Very High	Moderately Low	Moderate
Creep (extension-under sustained load):	Very Low	Moderate	Low	High
Water absorption of individual fibers:	High	Moderate	Moderate	Low
Resistance to rot, mildew, deterioration due to marine organisms:	Poor	Excellent	Excellent	Excellent
Chemical Resistance: Effect of acids:	Will disintegrate in hot dilute & cold concentrated acids.	Decomposed by strong mineral acids; resistant to weak acids.	Resistant to most mineral acids; disintegrated by 95% sulfuric acid	Good resistance
Effect of alkalis:	Little resistance	Little or none.	Little effect cold; slowly disintegrated by strong alkalis at boil	High resistance
Effect of organic solvents:	Low resistance: hydrocarbons will remove proactive lubricants on rope	Fair resistance: soluble in some phenotic compounds & 90% formic acid	Generally unaffected: soluble in some phenolic compounds	Soluble in chlorinated hydrocarbons at 160° F
Degradation: Resistance to U.V. in sunlight:	Fair	Good	Excellent	Fair; Black is best
Resistance to aging.	Good, but will lose strength as lubricants dry out.	Excellent	Excellent	Excellent
Rope Abrasion Resistance: Surface:	Good	Very Good	Best	Good
Internal:	Good	Excellent	Best	Good
Melting Point of Rope:	Not applicable	482° F	500° F	330° F
Ability of rope to render, or ease out, smoothly over metal while under load:	Excellent	Poor	Good	Very Poor

SYNTHETIC ROPE THIMBLES

INCREASES SLING LIFE, PROTECTS THE EYE, CUTS COST. LIGHT WEIGHT, HEAVY DUTY

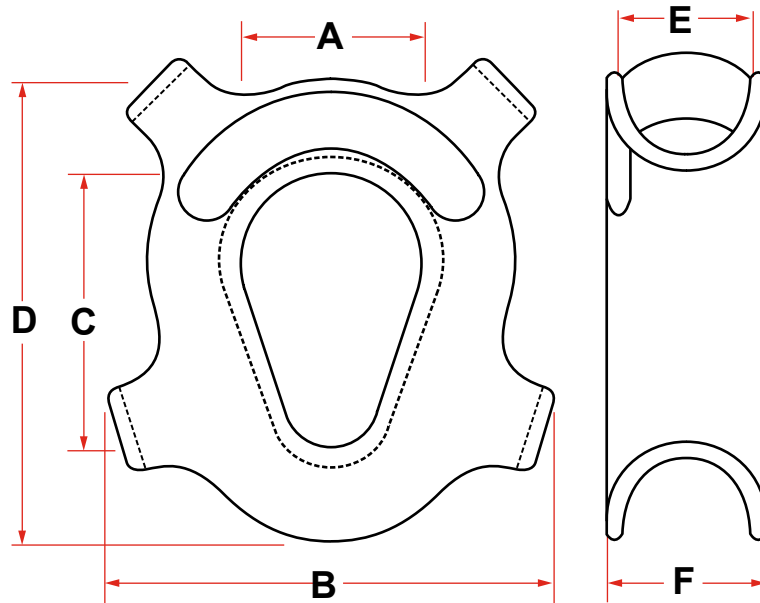

DIMENSIONS AND DATA

ROPE DIA.	ROPE CIRCUM.	A	B	C	D	E	F	APPROX. WT.
IN	IN	IN	IN	IN	IN	IN	IN	LBS
3/8 - 7/16	1-1/8 - 1-1/4	7/8	2-1/16	1-1/2	2-7/16	9/16	3/4	.25
1/2 - 9/16	1-1/2 - 1-3/4	1	2-3/8	1-5/8	2-13/16	11/16	29/32	.45
5/8 - 3/4	2 - 2-1/4	1-1/8	3-1/8	2	3-1/2	7/8	1-1/8	.60
13/16 - 15/16	2-1/2 - 2-3/4	1-1/4	3-3/4	2-15/16	4-3/16	1-1/16	1-3/8	.90
1 - 1-13/16	3 - 3-3/4	2	5-5/16	3-1/2	5-3/8	1-1/2	1-9/16	6
1-1/4 - 1-1/2	4 - 5	3-3/8	7	5-1/8	7-7/8	1-3/4	1-27/32	8
1-7/8 - 2-1/4	6 - 7	3-3/4	9-7/32	5-3/4	9-3/8	2-5/8	3-15/32	11
2-1/2	8	4-1/4	10-7/8	6-1/2	11	3-5/32	3-3/4	18
2-7/8	9	4-3/4	11-5/8	7-5/8	12	3-1/4	4-1/4	26
3-1/4	10	4-7/8	12-1/4	8-1/2	13-9/16	3-1/2	4-3/4	33
3-3/8 - 4	11-12	5-5/8	14-3/4	9-1/2	15-3/4	4-5/8	5-29/32	44
4-1/4 - 4-5/8	13-14	6-1/8	16-1/4	10	16-15/16	5-5/16	6-11/16	57
5 - 5-1/4	15-16	6-1/2	17-3/8	10-1/2	18	5-3/4	7-1/4	68
5-3/8 - 5-3/4	17-18	9	21-13/16	13-1/8	20-1/8	6-1/2	7-7/8	137
6 - 6-3/8	19-20	12	26-3/4	16-1/4	27	7-3/4	9-1/8	231
6-3/4 - 7	21-22	13-7/8	30-3/8	19-3/4	33-3/4	8-1/2	10-1/4	359

DECK FITTINGS

THESE ARE ONLY A SAMPLE OF SOME TYPES AVAILABLE.
MANY OTHERS IN STOCK.

LET US KNOW YOUR REQUIREMENTS!

STOCKS IN THE WEST COAST AND THE GULF.



DECK-MOUNTED BALANCED HEAD FAIRLEADERS



600 SERIES

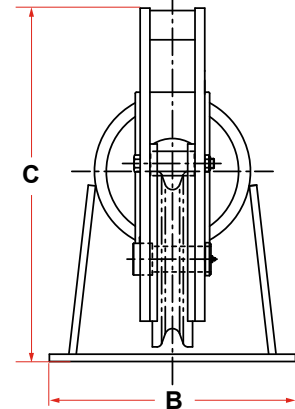
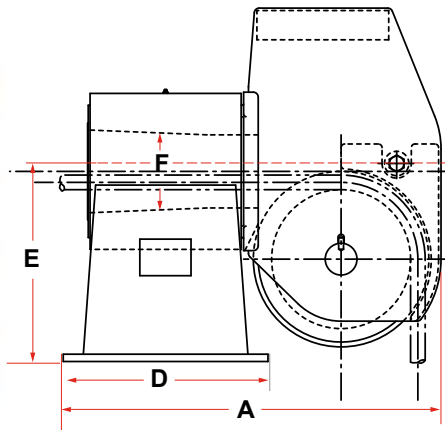

MODEL NO.	MAX WIRE SIZE	WIRE BREAKING STRENGTH (LBS)	SHEAVE THREAD DIA.	DIMENSIONS (INCHES)						WEIGHT (LBS)
				A	B	C	D	E	F	
MD-610	3/4	58800	8-1/4	23-11/16	16	20-1/8	14-3/4	11	4-1/2	270
MD-612	1	103400	9-3/4	28-3/16	19-1/4	24-5/8	17-3/4	13-1/2	5-5/8	495
MD-614	1-1/4	159800	11-1/4	30-9/16	20	28-1/8	18-1/2	15-1/2	6-5/16	670
MD-618	1-1/2	228000	14-1/4	38-1/8	25-1/4	36-1/4	21	19-1/2	8-1/2	1450
MD-622	1-3/4	266000	18-1/2	45-1/8	28-1/2	45-1/2	22	23-1/2	9-1/2	2100
MD-624	2	344000	20	50-1/8	30	44-13/16	27	25-1/2	12	2650
MD-630	2-1/4	494000	24-7/8	56-7/8	40-1/4	60-3/4	27-1/2	31-1/2	13	4800
MD-636	2-1/2	524000	30	63	40	70-1/4	27-1/2	36-1/4	14-1/2	6000
MD-652	3	818000	44	103-1/2	52-3/8	104	44	34-1/2	26-1/2	16500
MD-665	3	818000	55-1/2	115-5/8	52-3/8	117-1/2	44	34-1/2	26-1/2	18800

STANDARD FEATURES

- Designed for Breaking Strength of EIPS-IWRC Wire Rope with 90° Wrap on the Sheave and 180° Rotation of Swivelhead
- Cast Steel Sheave with Hardened Rope Groove for Longer Life
- Sealed Grease Lubricated Tapered Roller Bearings in Sheave and Swivelhead
- Weld Down Mounting Base
- Removable Guide Roller
- Epoxy Primer Coating

OPTIONAL FEATURES

- Customized Design to Suit Your Application
- Tail Sheaves / Tail Rollers
- Stainless Steel or Nylon Sheaves
- Bolt Down Mounting Base
- Load Monitoring System
- Three Coat Marine Paint System
- Third Party Certification

DECK-MOUNTED DOUBLE SHEAVE FAIRLEADERS



2600 SERIES

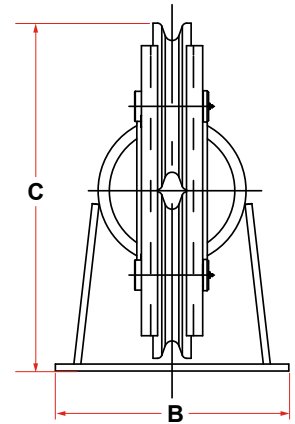
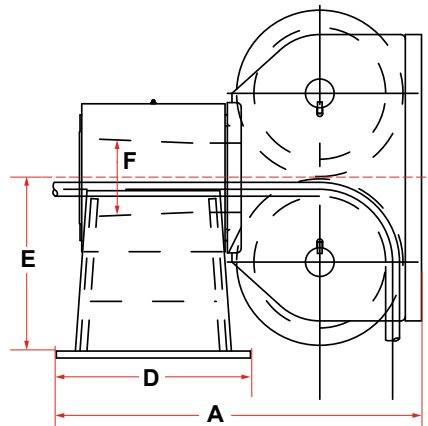

MODEL NO.	MAX WIRE SIZE	WIRE BREAKING STRENGTH (LBS)	SHEAVE THREAD DIA.	DIMENSIONS (INCHES)						WEIGHT (LBS)
				A	B	C	D	E	F	
MD-2610	3/4	58800	8-1/4	24-11/16	16	22	14-3/4	11	4-1/2	280
MD-2612	1	103400	9-3/4	29-13/16	19-1/4	25	17-3/4	13-1/2	5-5/8	520
MD-2614	1-1/4	159800	11-1/4	31-9/16	20	29	18-1/2	15-1/2	6-5/16	700
MD-2618	1-1/2	228000	14-1/4	39-1/8	25-1/4	37-5/8	21	19-1/2	8-1/2	1500
MD-2622	1-3/4	266000	18-1/2	46-1/8	28-1/2	48	22	23-1/2	9-1/2	2200
MD-2624	2	344000	20	51-1/8	30	49-5/8	27	25-1/2	12	2800
MD-2630	2-1/4	494000	24-7/8	57-7/8	40-1/4	61-5/8	27-1/2	31-1/2	13	5020
MD-2636	2-1/2	524000	30	64	40	72-5/8	27-1/2	36-1/4	14-1/2	6270
MD-2652	3	818000	44	104	52-3/8	105-5/8	44	34-1/2	26-1/2	17200
MD-2665	3	818000	55-1/2	117	52-3/8	130-5/8	44	34-1/2	26-1/2	19650

STANDARD FEATURES

- Designed for Breaking Strength of EIPS-IWRC Wire Rope with 90° Wrap on the Sheave and 180° Rotation of Swivelhead
- Cast Steel Sheaves with Hardened Rope Grooves for Longer Life
- Sealed Grease Lubricated Tapered Roller Bearings in Sheaves and Swivelhead
- Weld Down Mounting Base
- Removable Guide Roller
- Epoxy Primer Coating

OPTIONAL FEATURES

- Customized Design to Suit Your Application
- Tail Sheaves / Tail Rollers
- Stainless Steel or Nylon Sheaves
- Bolt Down Mounting Base
- Load Monitoring System
- Three Coat Marine Paint System
- Third Party Certification

HORIZONTAL GUIDE SHEAVES



1200 SERIES

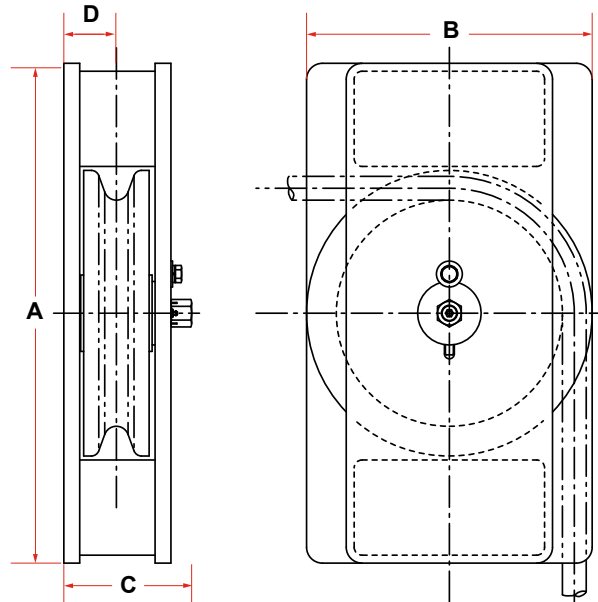

MODEL NO.	MAX WIRE SIZE	WIRE BREAKING STRENGTH (LBS)	SHEVE THREAD DIA.	DIMENSIONS (INCHES)				WEIGHT (LBS)
				A	B	C	D	
MD-1210	3/4	58800	8-1/2	17	11	5-1/2	2-3/16	85
MD-1212	1	89800	10	19	12	6-1/2	2-3/4	150
MD-1214	1-1/4	159800	11-7/16	21	14	7	2-3/4	200
MD-1218	1-1/2	228000	14-1/4	31-1/2	18	8	3-5/16	450
MD-1222	1-3/4	266000	18-1/2	41	22	8-1/2	3-1/2	880
MD-1224	2	344000	20	43	25	8-1/2	3-5/8	975
MD-1230	2-1/4	494000	24-7/8	45	30-5/8	11-1/2	4-1/8	1500
MD-1236	2-1/2	524000	30	55	37	13	5-3/4	2800
MD-1252	3	818000	44	83-1/2	53	14	6-1/4	6000
MD-1268	3-1/4	1223775	59-1/16	100	70	17	7	8000

STANDARD FEATURES

- Designed for Breaking Strength of EIPS-IWRC Wire Rope with 90° Wrap on the Sheave
- Cast Steel Sheave with Hardened Rope Groove for Longer Life
- Sealed Grease Lubricated Bronze Bearings in Sheave
- Weld Down Mounting Base
- Epoxy Primer Coating

OPTIONAL FEATURES

- Customized Design to Suit Your Application
- Multiple Sheaves
- Stainless Steel or Nylon Sheaves
- Bolt Down Mounting Base
- Load Monitoring System
- Three Coat Marine Paint System
- Third Party Certification

VERTICAL GUIDE SHEAVES



1100 SERIES

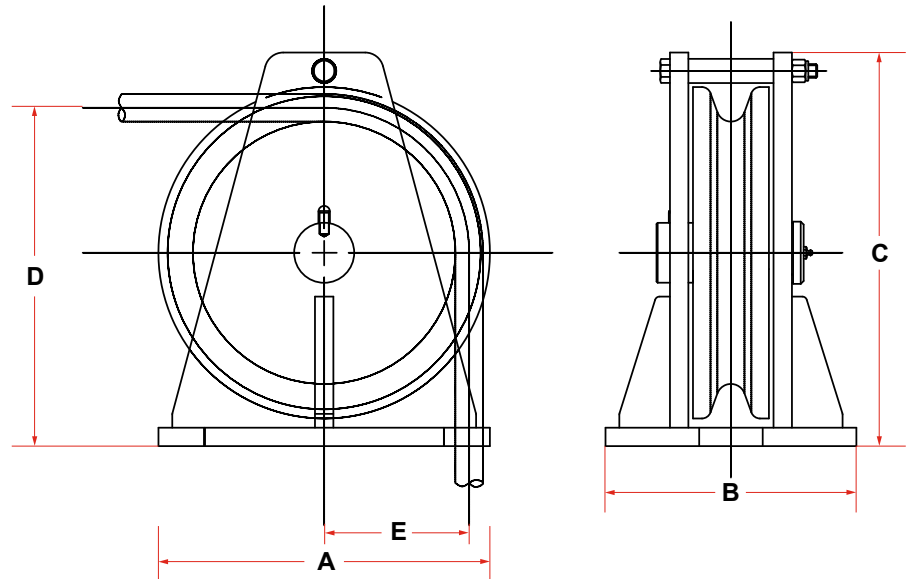

MODEL NO.	MAX WIRE SIZE	WIRE BREAKING STRENGTH (LBS)	SHEVE THREAD DIA.	DIMENSIONS (INCHES)					WEIGHT (LBS)
				A	B	C	D	E	
MD-1110	3/4	58800	8-1/4	11	9	20-1/8	10-1/4	4-1/2	65
MD-1112	1	103400	9-3/4	13	11-1/2	14-3/4	12-1/4	5-3/8	105
MD-1114	1-1/4	159800	11-1/4	16	12	17-1/2	14-1/2	6-1/4	185
MD-1118	1-1/2	228000	14-1/4	18	13-5/8	21-3/8	18-3/8	7-7/8	340
MD-1122	1-3/4	266000	18-1/2	22	16	26	22-7/8	10-1/8	550
MD-1124	2	344000	20	24	18	29	25-1/4	11	625
MD-1130	2-1/4	494000	24-7/8	30	23	35-3/8	31-1/16	30-15/16	1250
MD-1136	2-1/2	524000	30	36	27	43-1/2	37-3/4	16-1/4	3100
MD-1152	3	818000	44	52	39	60	53	23-1/2	4900
MD-1168	3-1/4	1223775	59-1/16	78-1/16	46	73-5/8	70-3/8	31-1/16	6020

STANDARD FEATURES

- Designed for Breaking Strength of EIPS-IWRC Wire Rope with 90° Wrap on the Sheave
- Cast Steel Sheave with Hardened Rope Groove for Longer Life
- Sealed Grease Lubricated Tapered Roller Bearings in Sheave
- Weld Down Mounting Base
- Removable Guide Roller
- Epoxy Primer Coating

OPTIONAL FEATURES

- Customized Design to Suit Your Application
- Multiple Sheaves
- Stainless Steel or Nylon Sheaves
- Bolt Down Mounting Base
- Load Monitoring System
- Three Coat Marine Paint System
- Third Party Certification

IMPORTED DOUBLE SHEAVE BALANCED HEAD FAIRLEAD

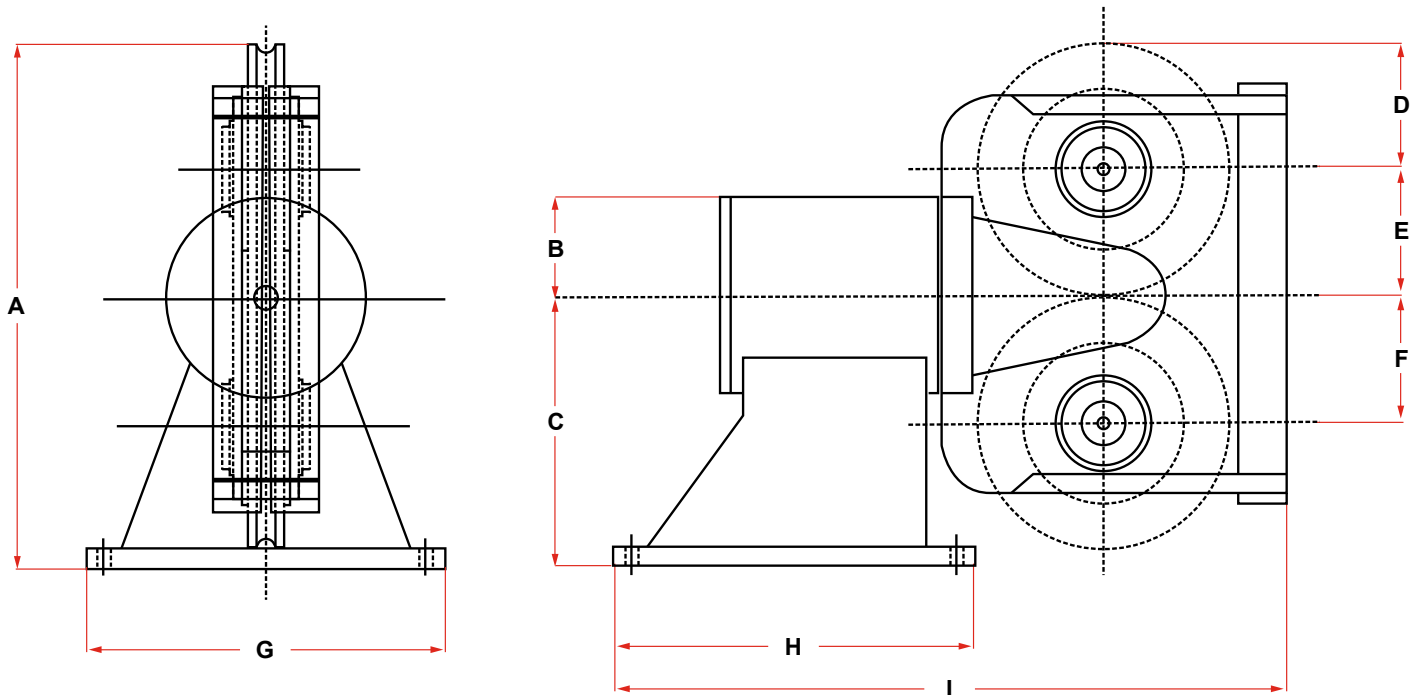

SIZE (IN)	DIMENSIONS (MM)									WEIGHT (KG)
	A	B	C	D	E	F	G	H	I	
1	531	100	275	127	129	129	365	365	679	195
1-1/4	667	127	365	150	152.5	152.5	660	508	920	495
1-1/2	867	178	459	205	205	205	760	760	1,280	1,080

PEDESTAL FAIRLEADERS

MODEL NO.	MAX WIRE SIZE	WIRE BREAKING STRENGTH (LBS)	DIMENSIONS (INCHES)					WEIGHT (LBS)
			A	B	C	D	E	
PFH-10	3/4	58800	14	10	18	16	15	300
PFH-12	1	103400	16	12	20	16	16	350
PFH-14	1-3/8	192000	19	14	23	16-3/4	19-5/16	480
PFH-16	1-3/8	192000	20-1/2	16	24	18-1/4	19-13/16	600
PFH-18	1-1/2	288000	24	18	28	19	21	890
PFH-24	2	396000	30	24	36	27	24-1/2	1700

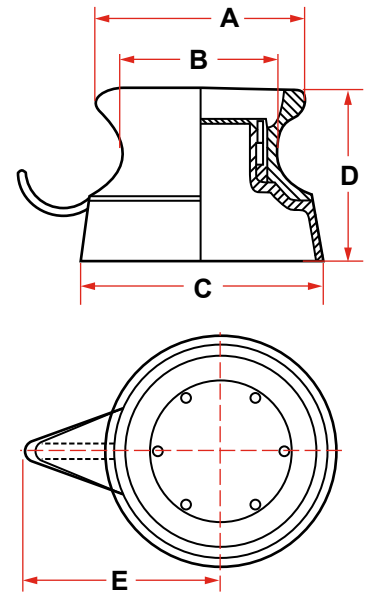

ROLLER FAIRLEADERS

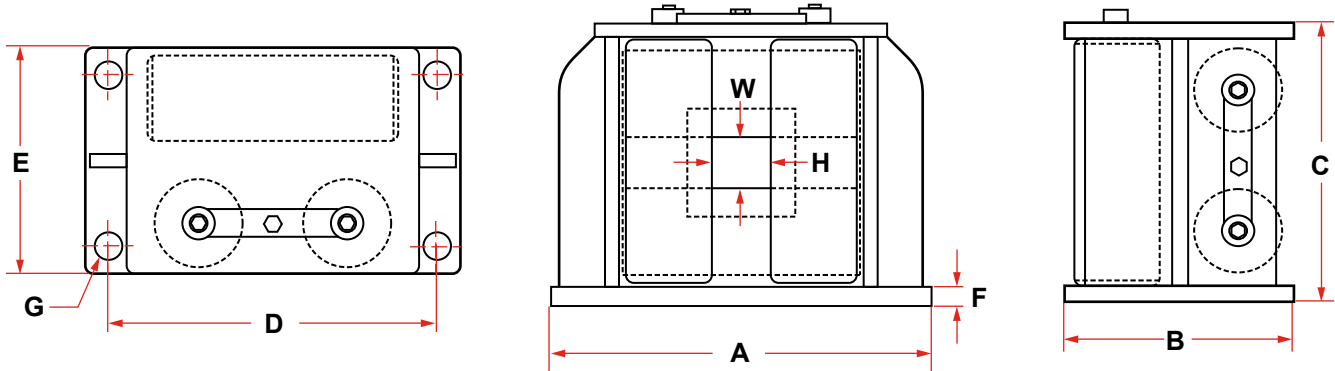

MODEL NO.	DIMENSIONS (INCHES)											NO. BOLT HOLES	LBS.	
	WIRE ROPER SIZE	VERTICAL ROLLER	HORIZONTAL ROLLER	OPENING W X H	A	B	C	D	E	F	G			ROLLER PIN
RF-0	5/16 to 3/8	2.25 x 6.50	2.25 x 6.50	2.25 x 2.25	12.000	5.250	8.188	10.250	3.875	0.500	25/32	1.000	4	52
RF-1	1/2 to 7/8	4 x 11.375	4 x 11.375	2.75 x 2.75	17.500	10.500	13.125	15.000	8.000	0.750	1.063	1.375	4	235
RF-2	1 to 1-1/4	6 x 15.375	5.00 x 11.00	5.00 x 4.00	26.000	17.000	18.500	22.000	12.500	1.125	1.531	1.500	4	700
RF-3	1-3/4	8.00 x 22.50	8 x 22.50	6.5 x 6.5	36.750	23.000	27.125	31.000	8.000	1.500	1.813	3.000	6	2400

MODEL NO.	DIMENSIONS (MM)											NO. BOLT HOLES	KGS	
	WIRE ROPER SIZE	VERTICAL ROLLER	HORIZONTAL ROLLER	OPENING W X H	A	B	C	D	E	F	G			ROLLER PIN
RF-0	8 to 10	57 x 165	57 x 165	57 x 57	305	133	208	260	98	13	20	25	4	24
RF-1	12 to 22	102 x 289	102 x 289	70 x 70	444	267	333	381	203	19	27	35	4	107
RF-2	25 to 32	152 x 391	127 x 279	127 x 102	660	432	470	559	318	29	39	38	4	318
RF-3	44	203 x 572	203 x 572	165 x 165	933	584	689	787	203	38	46	76	6	1089

Larger sizes available upon request.

4-ROLLER FAIRLEAD IMPORT (JIS F-2026)

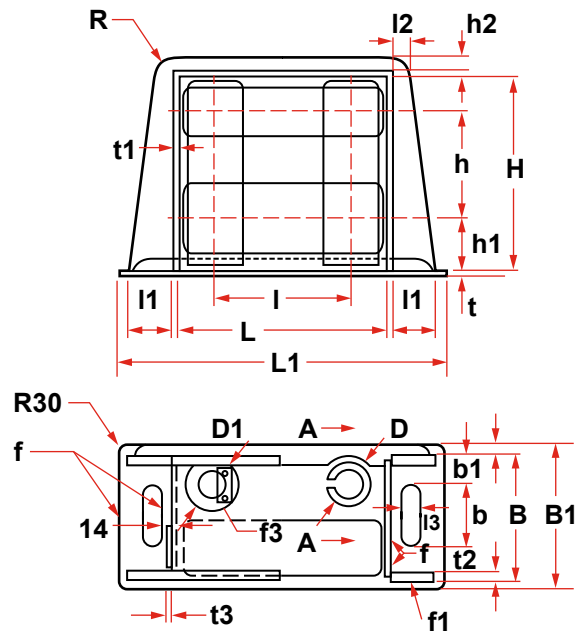

NOMINAL DIA.	FRAME																		SWL (TON)
	B	B1	B	B1	B2	D	D1	D2	D3	H	H	H1	H2	L	L1	I	I1	I2	
140	310	355	150	69	20	90	140	120	80	480	275	130	40	515	805	335	120	60	12
160	360	405	175	82	22	110	160	140	90	515	290	145	45	570	890	365	135	65	14
180	410	455	200	95	24	135	180	150	100	560	315	155	50	625	950	390	145	70	16
200	460	505	225	108	26	160	200	150	110	590	330	170	60	675	1049	420	160	80	25
250	565	510	280	133	30	200	250	200	130	715	415	195	75	820	1303	520	210	105	38
315	670	715	330	159	34	240	300	200	150	870	520	220	90	980	1562	520	260	130	45

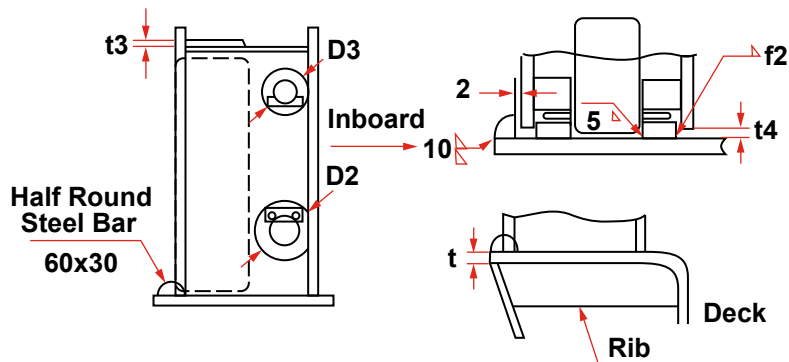

NOMINAL DIA.	FRAME							LEG OF WELD					WIRE ROPE DIA.	OPENING DIA. LONG X WIDE	REFERENCE MASS (KG)
	I3	I4	R	T	T1	T2	T3	F	F1	F2	F3	F4			
140	50	20	40	12	10	16	6	20	9	6	12	4	18	145 x 195	187
160	50	20	45	14	10	18	9	22	9	7	12	6	22.4	150 x 220	277
180	50	20	50	16	10	20	10	24	9	9	12	8	25	150 x 199	387
200	50	20	60	18	12	22	10	26	10	10	14	8	28	152 x 204	510
250	50	25	75	20	14	26	12	30	10	12	14	10	35.5	199 x 253	900
315	50	25	90	22	16	30	14	34	12	14	16	10	42.5	253 x 302	1232

PEDESTAL ROLLER FAIRLEADS - TYPE EU

HEIGHT : H	800	1000	1200	1400			WALL THICKNESS
ROLLER DIA : D	A	A	A	A	B	C	
300	715	800	900	1000	25	440	12
350	800	825	950	1120	30	500	12
400	1000	1020	1020	1150	35	560	16
450	1020	1022	1120	1180	35	630	16
500	1020	1120	1180	1250	40	710	16
560	1120	1180	1250	1380	40	800	16

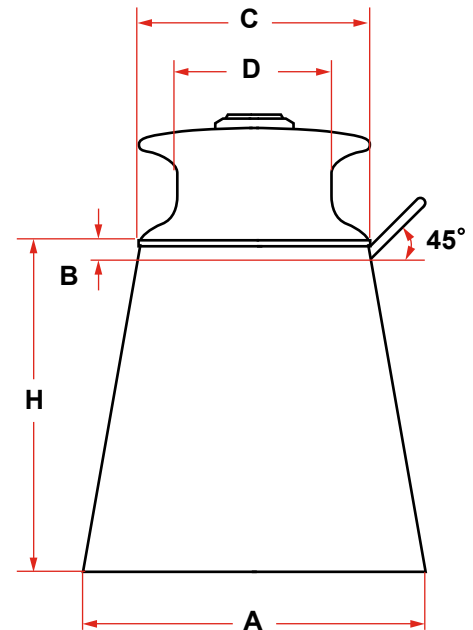

OTHER MODELS ROLLER BUTTONS

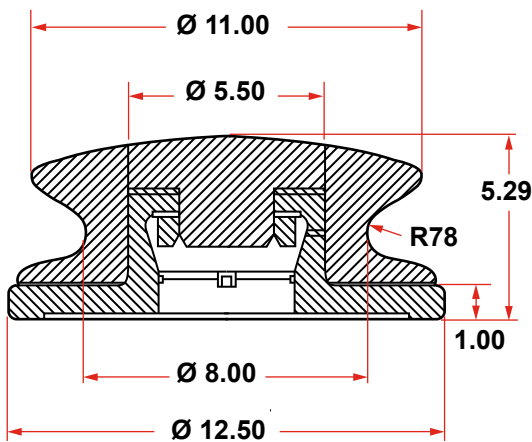

MODEL 50

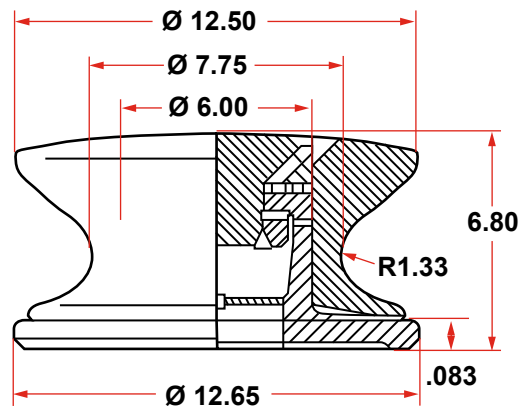

MODEL 75

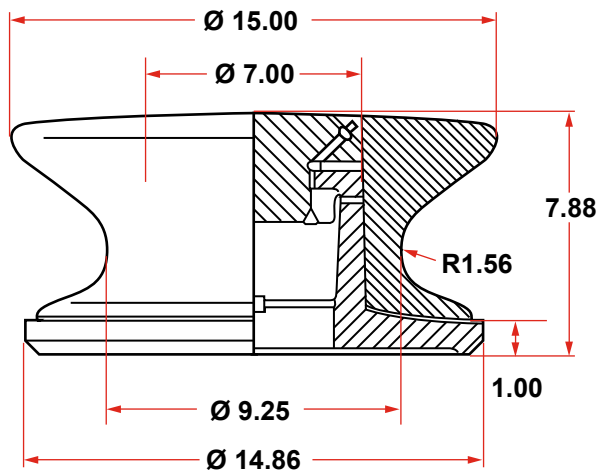

MODEL 100

ROLLER BUTTONS FREE ROLLING

These are the finest high-loaded carrying, free-rolling roller buttons that have ever been designed, and are manufactured in sizes to suit the needs of boats, seagoing tugs and ships. Precision machined parts have working parts coated with an extremely hard coating - 70 Rockwell C-Scale - which is corrosion resistant. The buttons will not freeze up as most do, because they are closed at the top. The air pocket formed on the inside, makes it practically impossible for water to enter the working parts. Before shipment, the roller buttons are completely lubricated and should need only occasional attention after installation and use.

CAST STEEL BUTTON CHOCKS

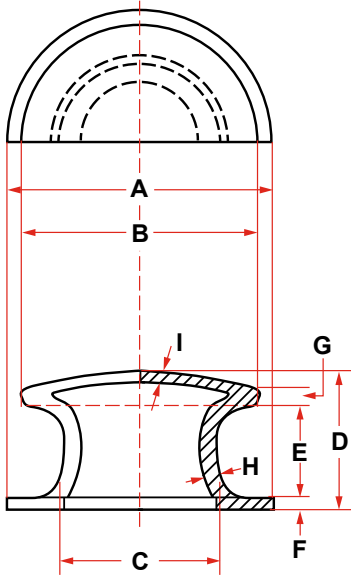

DIMENSIONS (INCHES)										WEIGHT (LBS)
SIZE	A	B	C	D	E	F	G	H	I	
10	17	15	10	8-1/2	5-3/4	5/8	1-1/8	1	1/2	138

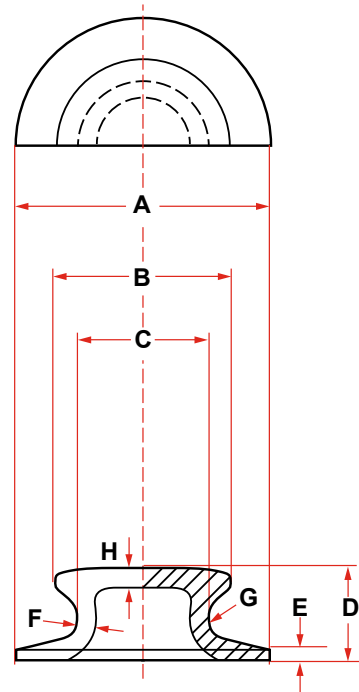

DIMENSIONS (INCHES)									WEIGHT (LBS)
SIZE	A	B	C	D	E	F	G	H	
6	12	8-1/2	6	4-1/8	1/2	3/4	1-1/2	3/4	38

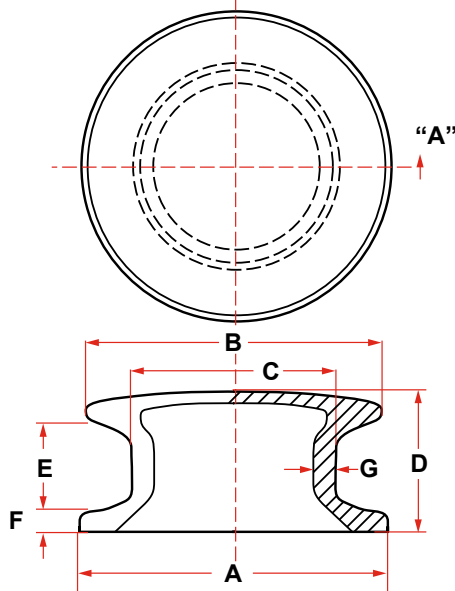

DIMENSIONS (INCHES)									WEIGHT (LBS)
SIZE	A	B	C	D	E	F	G		
8	13	12-1/2	8-5/8	5-1/4	3-11/16	3/4	7/8	75	

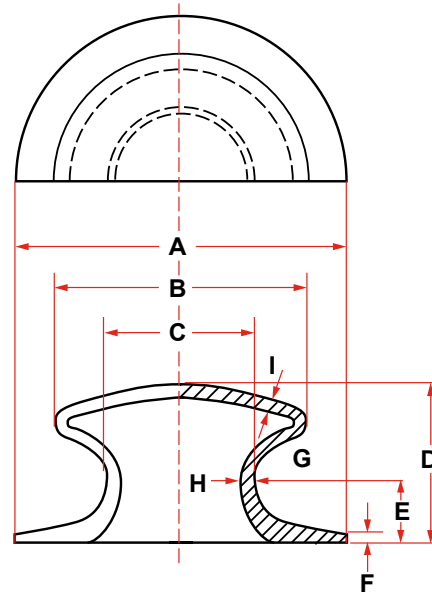

DIMENSIONS (INCHES)										WEIGHT (LBS)
SIZE	A	B	C	D	E	F	G	H	I	
9	20	15-1/2	9	9-1/2	3-1/2	5/8	2-1/2	3/4	1/2	158

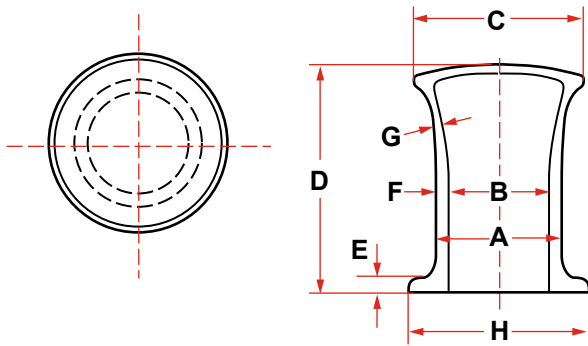

CAST STEEL SINGLE BITT

MODEL NO.	PART NO.	SIZE	DIMENSIONS (INCHES)								WEIGHT (LBS)
			A	B	C	D	E	F	G	H	
DF-SB10	20230	10	10	8	13-1/2	18	1	1	3/4	14	190

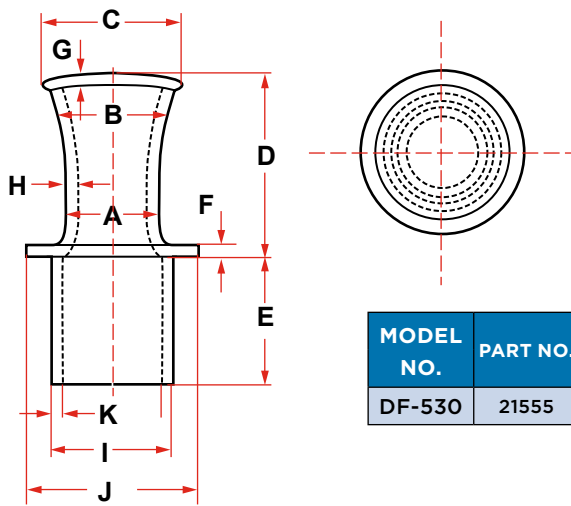

CAST STEEL SINGLE BITT THRU DECK

MODEL NO.	PART NO.	SIZE	DIMENSIONS (INCHES)											WEIGHT (LBS)
			A	B	C	D	E	F	G	H	I	J	K	
DF-530	21555	8	8	10-1/2	12	16	11	1	1	1	10-1/4	14	3/4	260

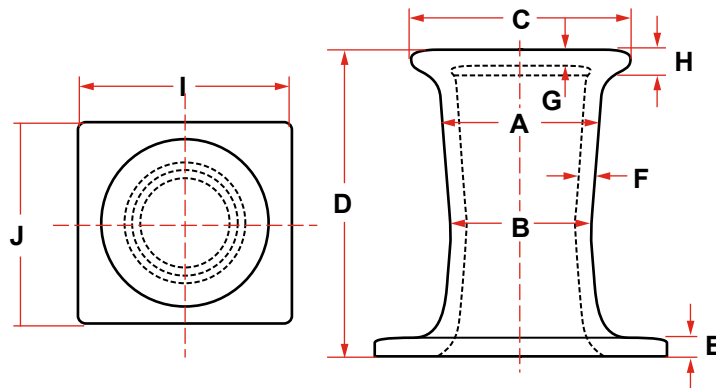

CAST STEEL SINGLE BITT

MODEL NO.	PART NO.	SIZE	DIMENSIONS (INCHES)										WEIGHT (LBS)
			A	B	C	D	E	F	G	H	I	J	
DF-588	87971	8	8	7	11	14-3/4	1-1/4	1	3/4	1-1/2	14	14	160

CAST STEEL DOUBLE BITTS

LARGER SIZES
AND TYPES
AVAILABLE
UPON REQUEST

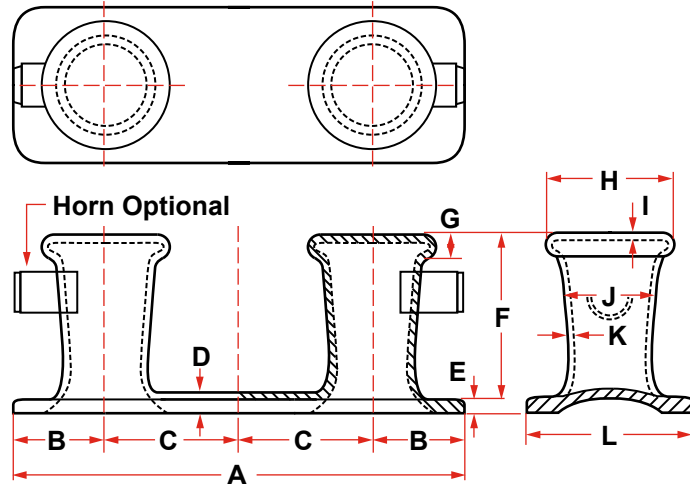

MODEL NO.	SIZE	DIMENSIONS (INCHES)												WEIGHT (LBS)
		A	B	C	D	E	F	G	H	I	J	K	L	
DF-2	8	40	8	12	2	1-1/4	16	2	11	5/8	7	5/8	14	320
DF-2A	w/ Horn													330
DF-40	10	45	9	13-1/2	2-1/4	1-1/4	18	2	13-1/2	3/4	9	1-1/4	15	545
DF-40A	w/ Horn													560

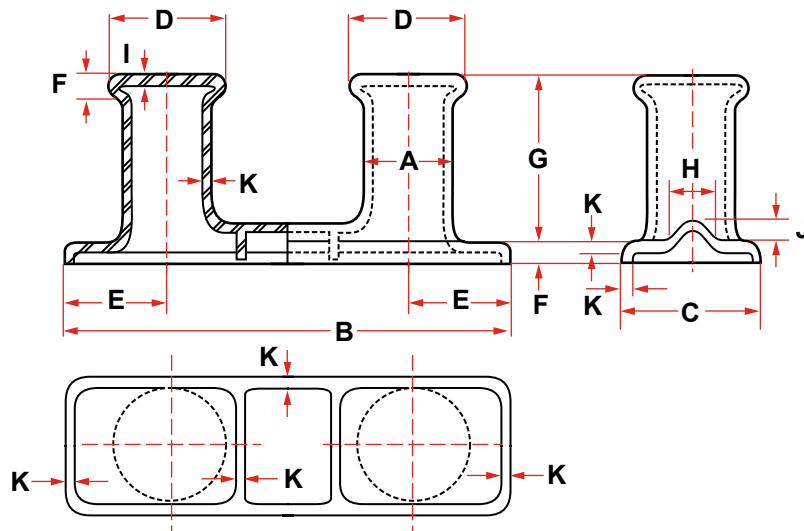

MODEL NO.	SIZE	DIMENSIONS (INCHES)											WEIGHT (LBS)
		A	B	C	D	E	F	G	H	I	J	K	
DF-491	12	12	60	18	15	13-1/2	3	22-1/2	6	1	2	1-1/4	990
DF-498	14	14	66	21	17-1/2	13	3-1/2	26-1/4	7	1	2	1-1/2	1350

STANDARD MARINE CLEATS

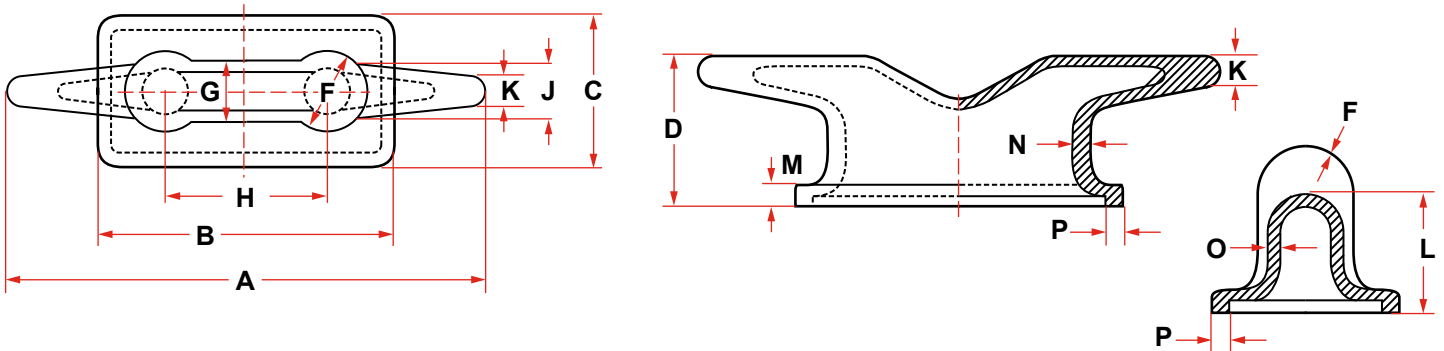

DIMENSIONS (INCHES)														PATTERN NO.	WEIGHT (LBS)
A	B	C	D	F	G	H	J	K	L	M	N	O	P		
8	6	4-1/2	3	1-1/2	1-1/4	3	1-1/4	1/2	2	1/2	5/8	1/2	1/2	17002	12
10	6-3/4	5	3-1/4	1-3/4	1-3/8	3-1/2	1-3/8	5/8	2-1/4	1/2	5/8	1/2	1/2	17190	14
12	7-1/2	5-1/2	3-1/2	2	1-1/2	4-1/2	1-1/2	3/4	2-1/2	5/8	5/8	1/2	5/8	17295	16
16	10-1/2	7-1/8	5	2-1/2	2	5-1/4	2	7/8	3-1/2	1	7/8	9/16	5/8	17300	32
20	13	6-1/4	6	3-1/2	2-1/2	6-1/2	2-1/4	1-1/8	4-1/2	1-1/8	1	5/8	3/4	4740	48
24	15-1/2	9-1/2	7-1/4	4	3	8	3	1-3/8	5-1/4	1-1/4	1-1/8	11/16	7/8	5353	65
30	19	11-1/4	8	5	3-1/2	10	3-1/2	1-3/4	6-1/2	1-3/8	1-1/4	3/4	1	4732	120
36	22-1/2	12-1/4	10-1/2	6	4-1/2	12	4	2	7-1/2	1-1/2	1-3/8	13/16	1-1/8	4742	193
42	26	13-1/4	12	7	5-1/4	14	4-1/2	2-3/8	8-1/2	1-5/8	1-1/2	7/8	1-1/4	4733	285
48	29-1/2	15-1/4	14	8	6	17	5-1/2	2-3/4	9-1/2	1-3/4	1-5/8	15/16	1-3/8	16632	315
54	33-1/2	16-1/2	15-1/2	9	6-1/2	18	6	3	11	2	1-3/4	1	1-1/2	16690	500

CLEATS

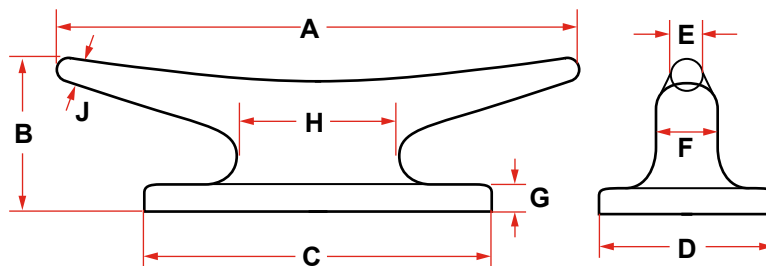

DIMENSIONS (INCHES)								
A	B	C	D	E	F	G	H	J
8	3	5	3	5/8	1-1/4	1/2	3	5/8
12	3-1/2	8	4	5/8	1-3/8	9/16	3-3/4	5/8
14	4	8	4-1/2	3/4	2	3/4	4-1/8	3/4
16	4-1/2	8	5	7/8	2-1/2	7/8	4-1/2	7/8
18	5	9	5-1/2	1	3	7/8	4-7/8	1

DOUBLE BITTS, FABRICATED 8" TO 20" (JIS F-2001)

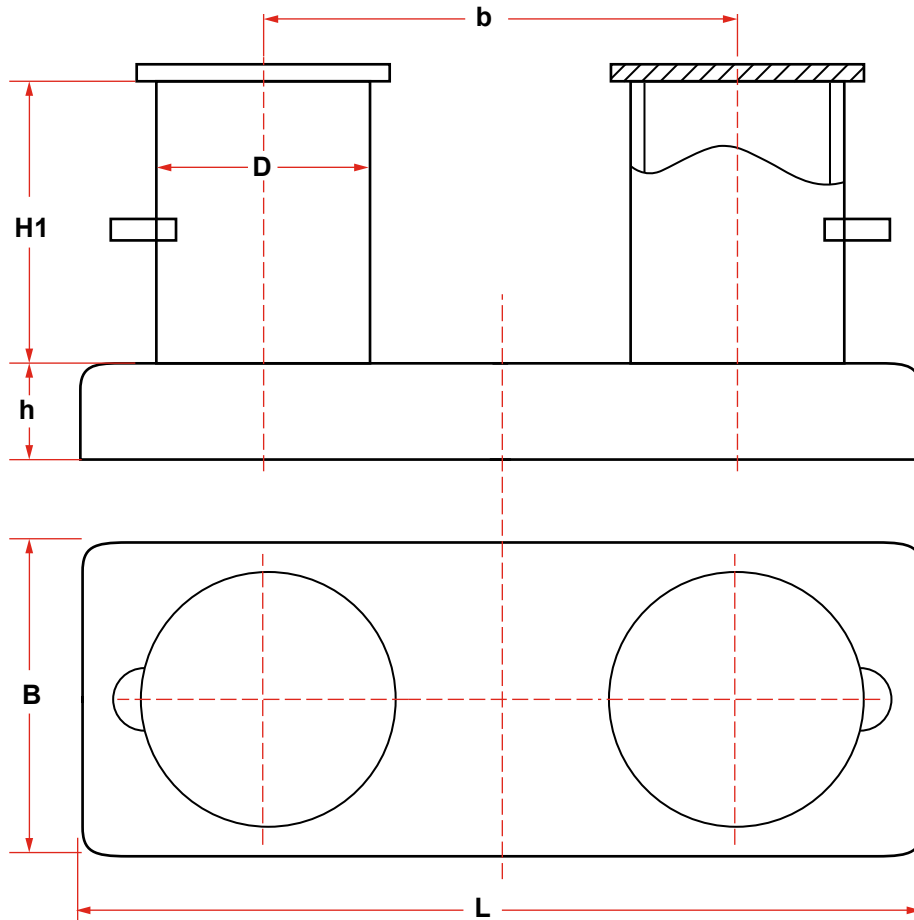

NOMINAL DIA.	DIMENSIONS (MM)						MAX B.L. OF ROPE (TON)	MASS (KG)
	D	H1	b	B	L	h		
100	114	150	250	165	445	50	3	19
125	139	190	315	195	540	60	4	29
160	165	250	400	225	670	70	5	45
200	216	300	500	290	860	85	8	80
250	267	380	630	360	1065	100	12	139
315	318	480	800	430	1300	125	20	261
355	355	530	890	480	1475	145	26	361
400	406	600	1000	550	1630	160	32	502
450	457	680	1130	620	1840	170	39	685
500	508	750	1250	690	2040	190	46	911
560	558	830	1380	750	2240	210	56	1208
630	609	940	1570	820	2510	225	70	1600
710	711	1050	1750	960	2840	260	82	2252
800	812	1200	2000	1100	3240	295	100	3071

KEVEL

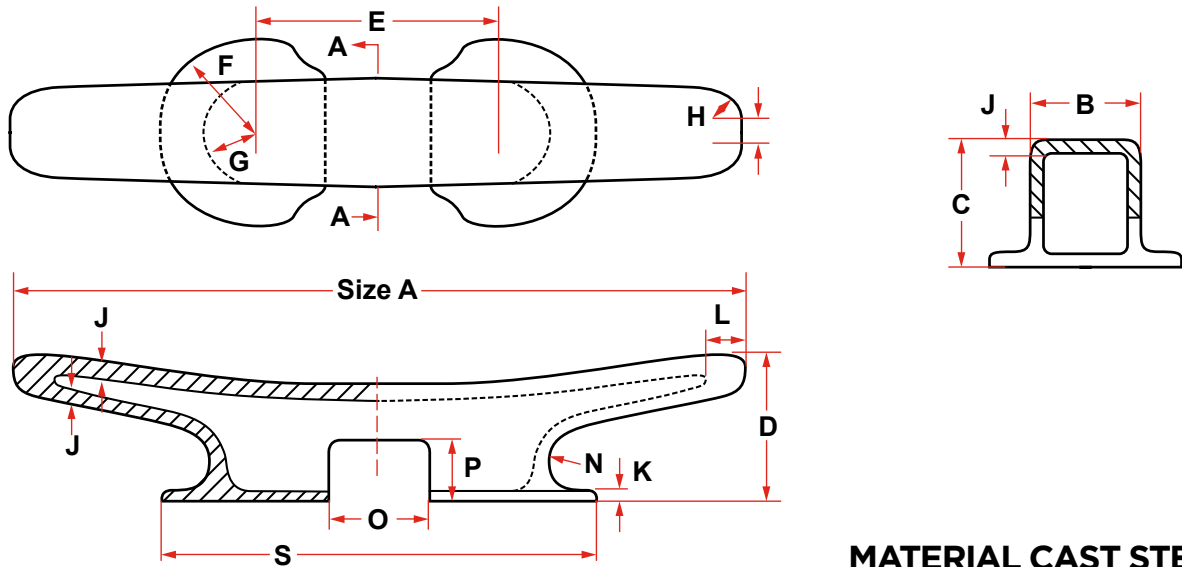

MATERIAL CAST STEEL

DIMENSIONS (INCHES)																	
A	B	C	D	E	F	G	H	I	J	K	L	M	N	O	P	S	
30	4	5	6-1/8	10	4	2	1-1/4	3/4	1/2	3/8	1-3/4	3/4	1	4	2-1/4	18	
36	5	5-7/8	7-1/8	12	5	2-1/2	1-1/2	1	9/16	1/2	2-1/8	7/8	1-1/2	5	2-3/4	22	
42	6	7	8-1/2	14	6	3	1-7/8	1-1/4	5/8	5/8	2-1/2	1	2	6	3-1/4	26	
48	7	9	10	16	7	3-1/2	2	1-1/2	3/4	3/4	4	1-1/4	2-1/2	7	4	30	
60	7	9	13	20	9	4-1/2	2	1-3/4	3/4	3/4	4	1-1/4	2-1/2	9	4	38	

KEVEL CHOCK

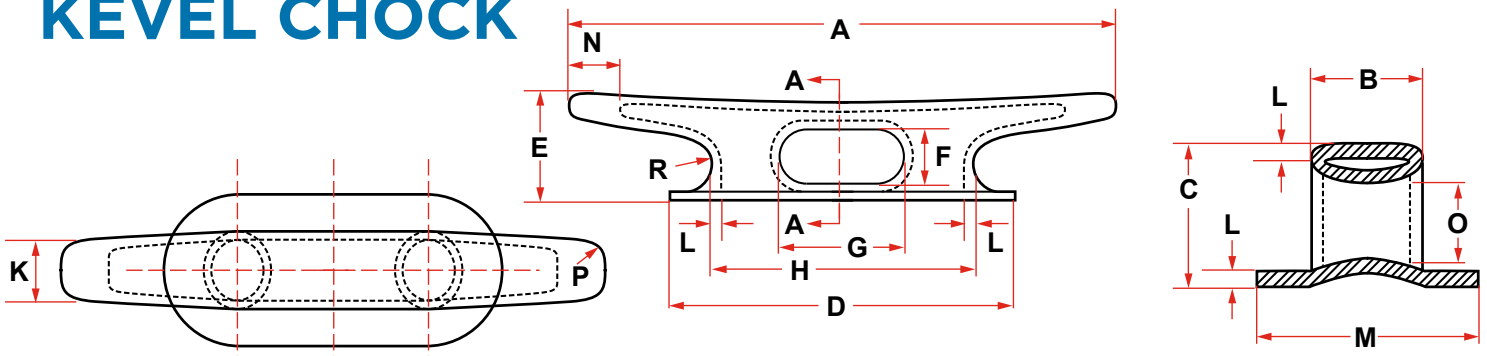

DIMENSIONS (INCHES)																
A	B	C	D	E	F	G	H	K	L	M	N	O	P	R	T	
24	3	4-1/2	17	6	1-1/2	5-1/2	11	1-1/2	1/2	8	2	1-1/2	1-1/8	1	3/4	
30	4	5-5/8	20-1/4	7	2-3/8	6-7/8	14	3-1/4	1/2	9-1/2	2	2-3/8	1-1/4	1-3/8	7/8	
36	5	6-3/4	23-1/2	8	3-1/4	8-1/4	17	4	9/16	11	2-1/2	3-1/4	1-1/2	1-3/4	1	
42	6	7-7/8	26-3/4	9	4-1/8	9-5/8	20	4-3/4	5/8	12-1/2	2-3/4	4-1/8	1-7/8	2-1/8	1-1/8	
48	7	9	30	10	5	11	23	5-1/2	3/4	14	4	5	2	2-1/2	1-1/4	

DECK MOUNT PLAIN CHOCK

Pads for Bolting to Wooden Dock Omitted Unless Specified on Order.

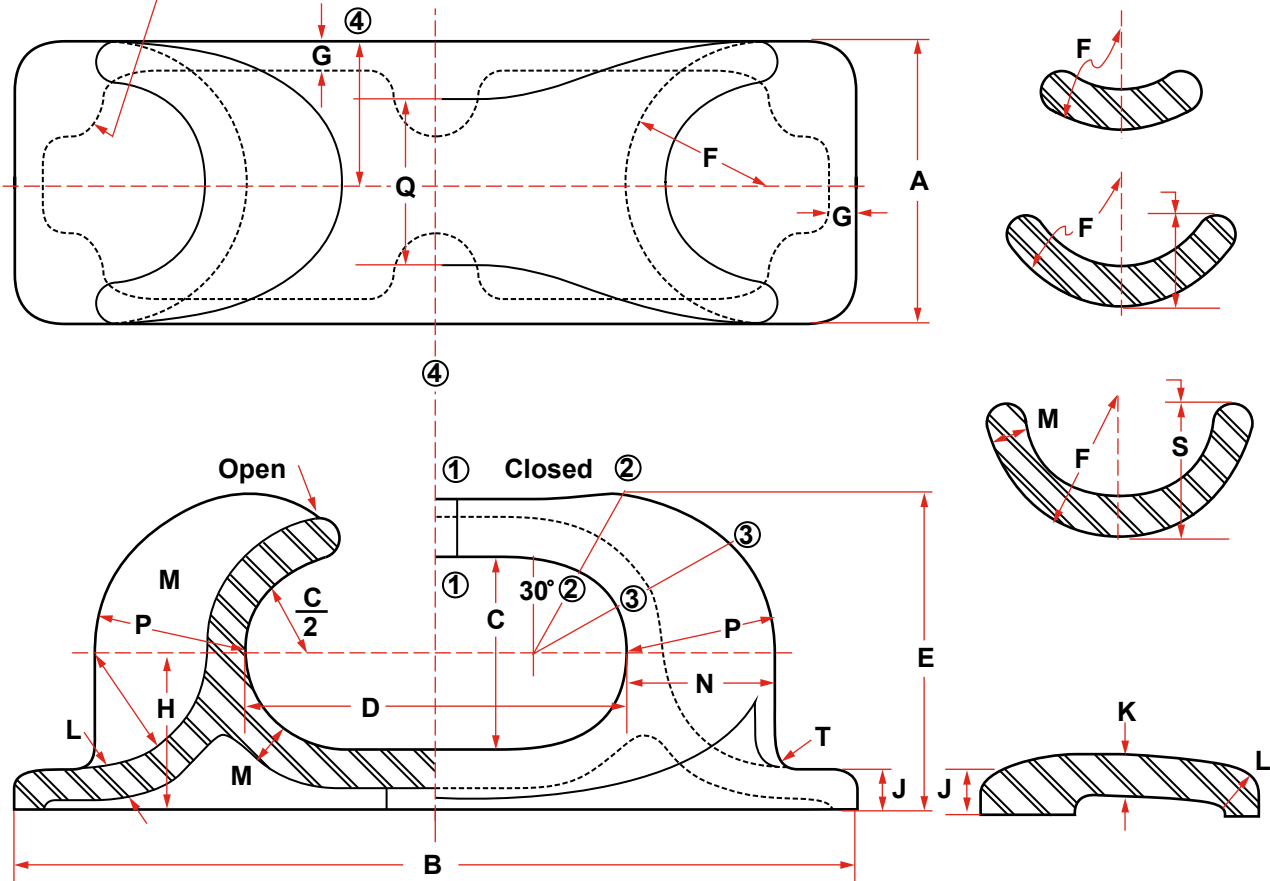

SIZE	DIMENSIONS (INCHES)																
A	B	C	D	E	F	G	H	J	K	L	M	N	P	Q	R	S	T
6	19-3/4	4	8	6-3/4	3	3/4	3-3/8	1	1-3/8	3/4	1	3-1/4	3-3/8	3-1/2	1-7/8	2-7/8	3/8
7	22-3/8	4-3/8	9-1/4	7-7/8	3-1/2	3/4	3-15/16	1-3/16	1-3/8	7/8	1-1/8	3-13/16	3-15/16	4-1/8	2-3/16	3-15/16	3/8
8	25-1/4	5-3/8	10-3/4	9	4	7/8	4-1/2	1-5/16	1-13/16	1	1-1/4	4-3/8	4-1/2	4-3/4	2-9/16	3-3/4	1/2
9	27-3/4	6	12	10-1/8	4-1/2	7/8	5-1/16	1-1/2	2-1/16	1-1/8	1-3/8	4-7/8	5-1/16	5-1/4	2-7/8	4-1/4	1/2
10	30-3/8	6-5/8	13-1/4	11-1/8	5	1	5-1/2	1-9/16	2-3/16	1-1/4	1-1/2	5-7/16	5-3/8	5-7/8	3-3/16	4-3/4	5/8
11	33-1/4	7-3/8	14-3/4	12-1/4	5-1/2	1	6-1/16	1-11/16	2-3/8	1-3/8	1-5/8	6	6-3/16	6-1/2	3-1/2	5-1/4	5/8
12	36	8	16	13-3/8	6	1-1/4	6-5/8	1-7/8	2-5/8	1-1/2	1-3/4	6-1/2	6-3/4	7	3-7/8	5-3/4	3/4
14	42	9-3/8	18-3/4	15-5/8	7	1-1/4	7-3/4	2-3/16	3-1/16	1-3/4	2	7-5/8	7-7/8	8-1/4	4-1/2	6-11/16	7/8
18	54	12	24	20	9	1-1/2	9-7/8	2-3/4	3-7/8	2-1/4	2-1/2	10-1/8	10-1/8	10-1/2	5-3/4	8-5/8	1-1/8

CHOCKS - DECK MOUNTED, SIZE 10" X 12"

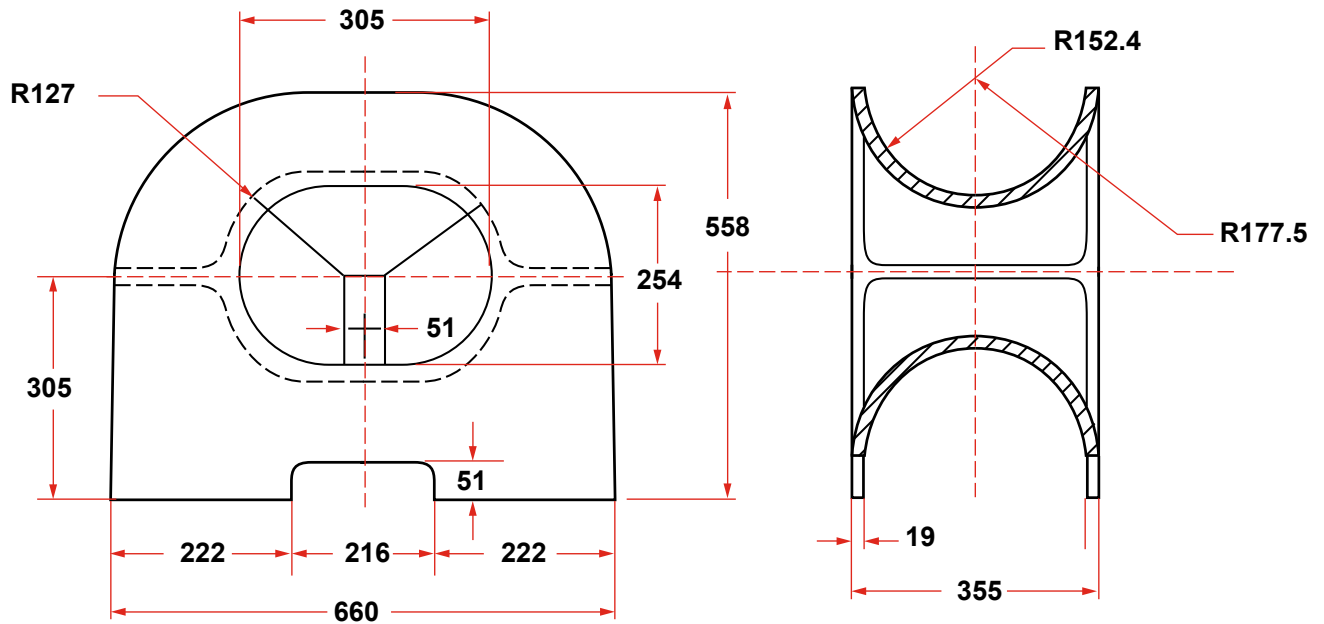

CHOCKS - DECK MOUNTED, SIZE 10" X 14"

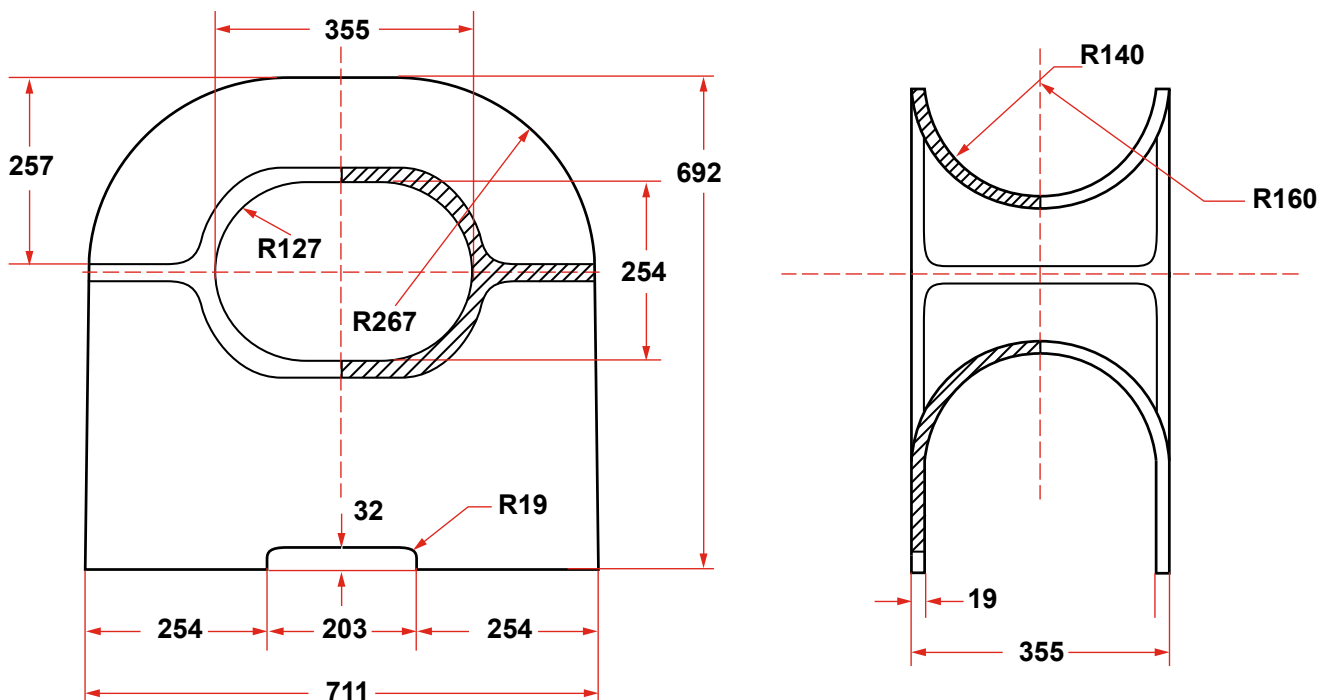

MEASUREMENTS ARE IN MILLIMETERS

CHOCKS - DECK MOUNTED, SIZE 12" X 18"

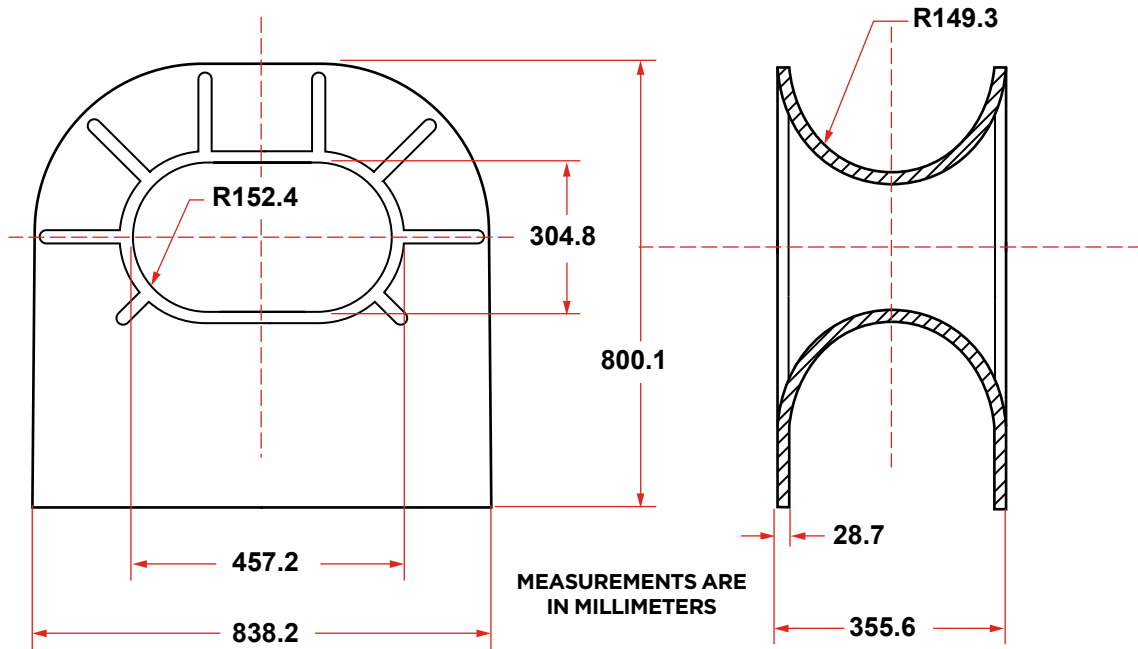

CHOCKS - DECK MOUNTED, TYPE EU SIZES 10" X 12" - 18" X 24"

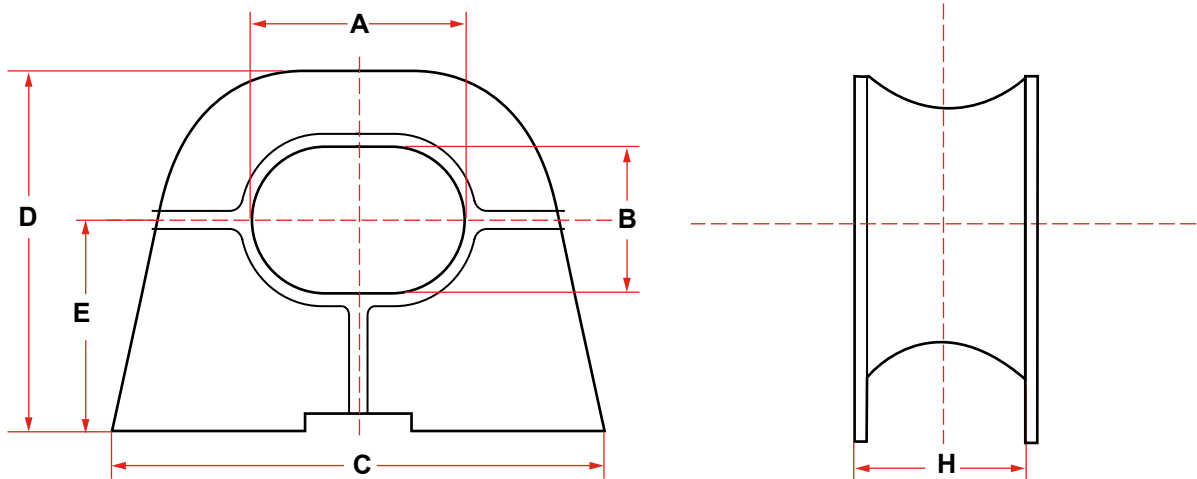

NOMINAL SIZE	DIMENSIONS (MM)						MASS (KG)
	A	B	C	D	E	H	
315 x 250	315	250	815	620	365	380	230
425 x 280	425	280	1075	785	450	500	378
600 x 315	600	315	1360	865	507	560	598
600 x 450	600	450	1360	1000	575	560	655
600 x 450	600	450	1560	1200	675	760	780

BULWARK MOUNTED PANAMA CHOCK

EU TYPE

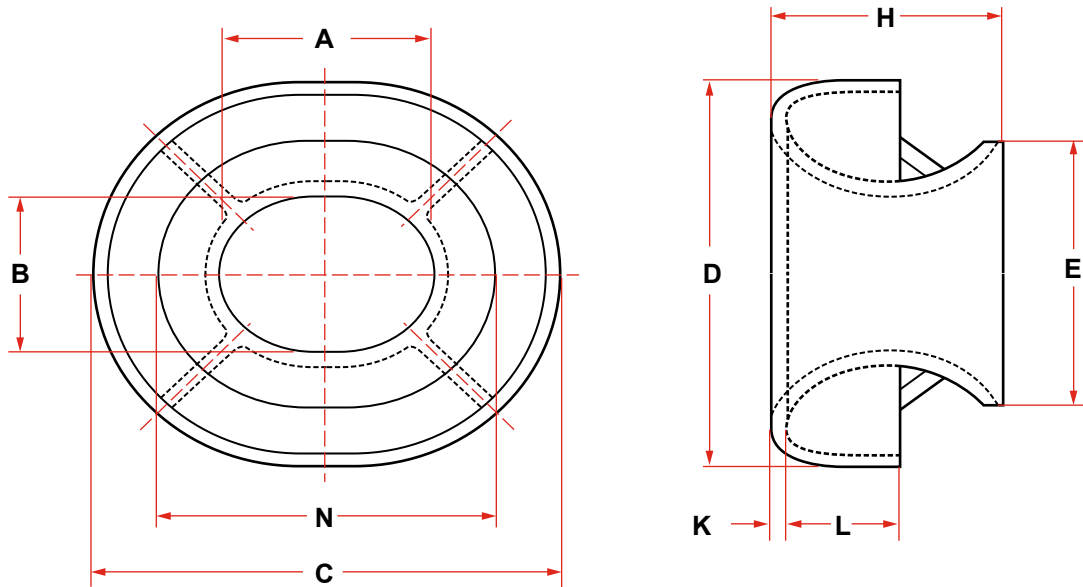

DIMENSIONS (MM)									MASS (KG)
A	B	C	D	E	H	K	L	N	
315	250	695	630	432	342	22	168	497	198
425	280	925	780	516	450	26	224	661	358
600	315	1160	875	571	504	30	250	866	547
600	450	1160	1010	706	504	30	250	866	629
600	450	1360	1160	1060	504	30	250	1260	813

BULWARK MOUNTED PANAMA CHOCK

(JIS F-2017 TYPE BC)

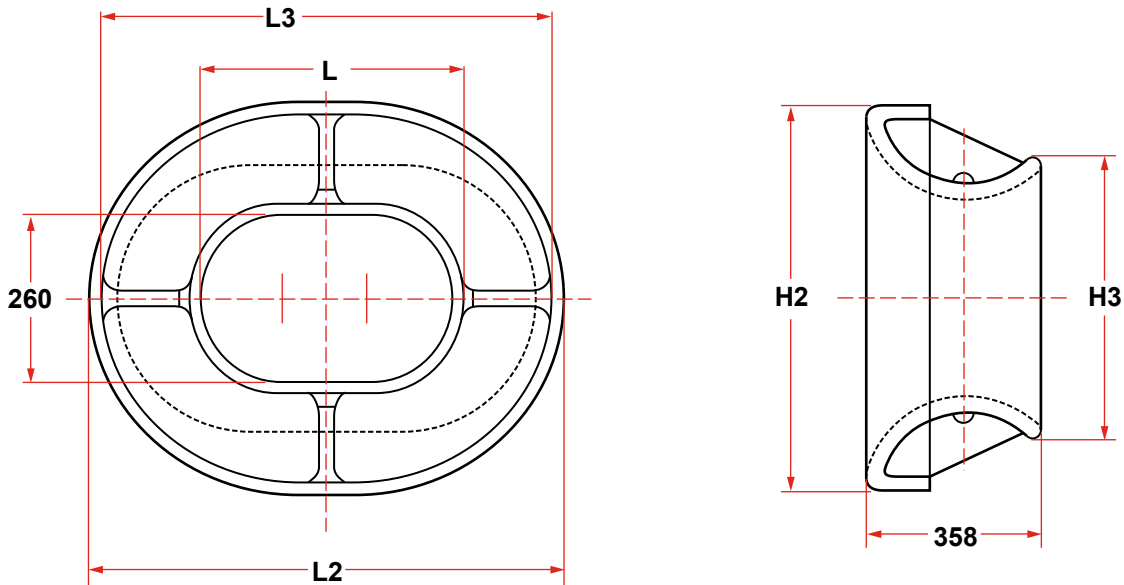

DIMENSIONS (MM)						MASS (KG)
NOMINAL SIZE	L	L2	L3	H2	H3	
310	310	734	652	684	462	276
360	360	788	701	688	464	305
400	400	832	750	692	470	344
450	450	888	802	696	474	385
500	500	940	854	700	478	422

WELD ON STEEL CLEATS

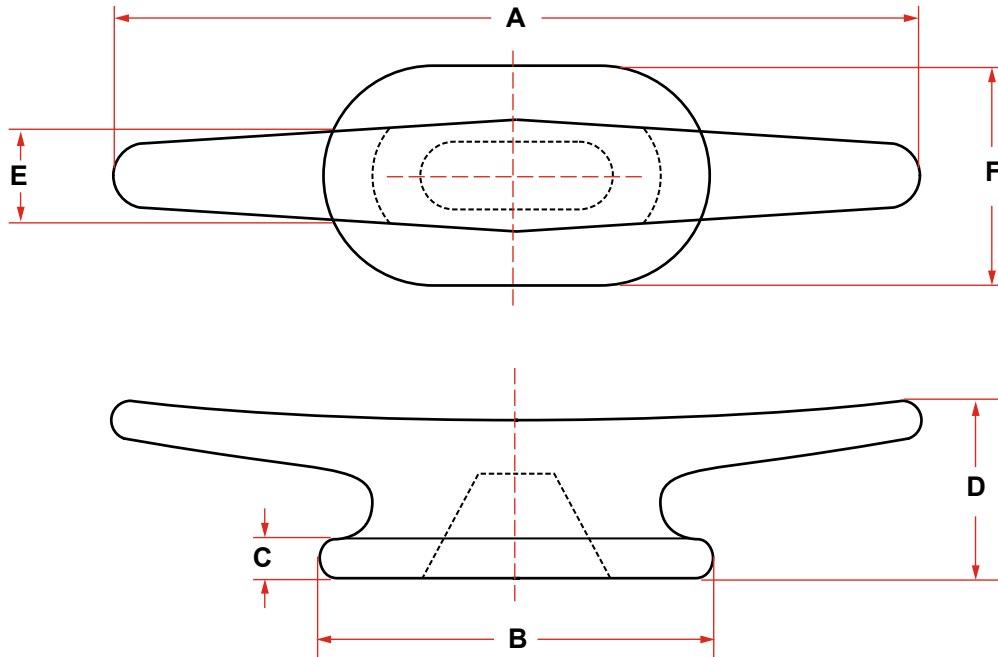

ASTM A27 GRADE 70-36 CAST STEEL

CLEAT SIZE (INCHES)	DIMENSIONS (MM)						WEIGHT (LBS)
	A	B	C	D	E	F	
8	8.00	4.40	0.35	1.70	1.25	2.14	3.00
10	10.00	5.13	0.40	2.24	1.42	2.53	4.30
12	12.00	5.55	0.55	2.75	1.70	3.50	8.00
14	14.00	7.00	0.53	3.20	2.13	4.00	13.00
16	16.00	8.25	0.75	3.50	2.13	4.50	17.00
18	18.00	9.25	0.85	4.26	2.63	4.75	24.00

HORN CLEATS - STEEL

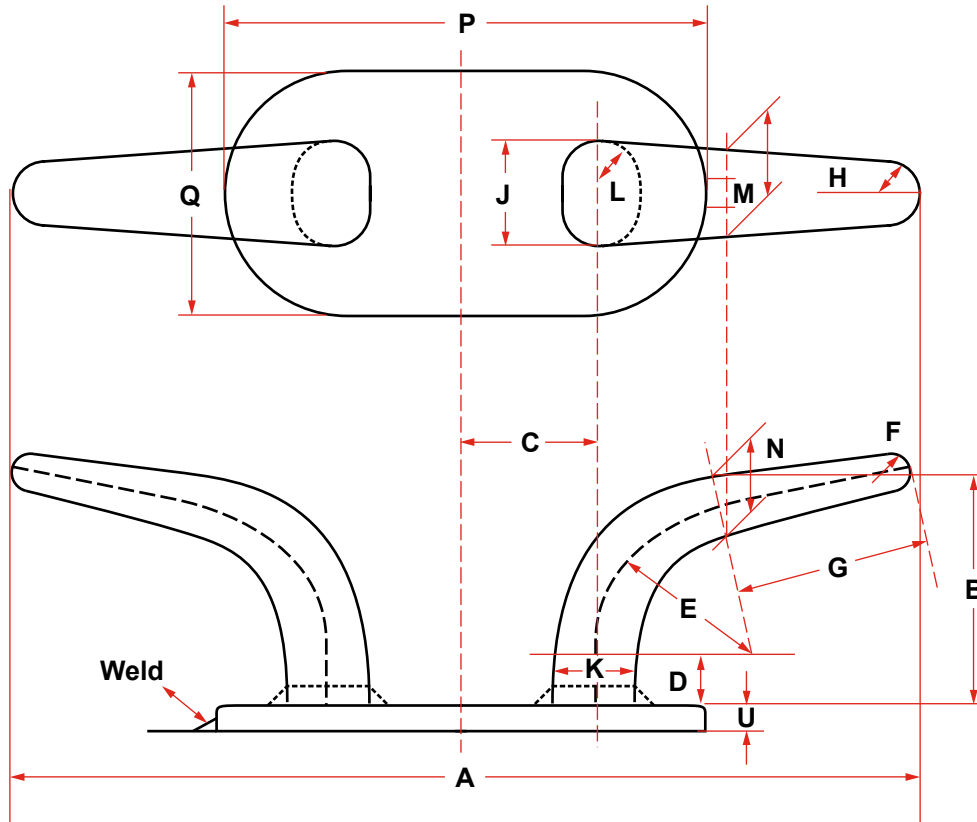

DIMENSIONS (INCHES)															
A	B	C	D	E	F	G	H	J	K	L	M	N	P	Q	U
8	2	1	1/2	1-1/4	5/32	1-15/16	5/32	11/16	11/16	-	9/16	9/16	4	2	1/4
10	2-5/8	1-1/2	1/2	1-3/4	3/16	2-5/32	3/8	1-1/4	7/8	7/16	1-1/6	11/16	5-3/8	2-3/4	5/16
12	3-1/4	1-3/4	3/4	2	3/16	2-23/32	7/16	1-5/8	1-1/8	9/16	1-3/8	7/8	6-3/8	3-1/4	3/8
16	4	2-5/8	1	2-1/2	1/4	3-7/8	9/16	2	1-1/4	5/8	1-3/4	1	8-1/4	4	1/2
18	4-1/2	2-5/8	1-1/8	2-3/8	5/16	4-11/16	5/8	2-1/2	1-1/2	3/4	2-1/8	1-1/8	9-1/8	5	5/8
20	5	2-3/4	1-1/4	2-5/8	5/16	5-3/8	3/4	2-3/4	1-5/8	13/16	2-3/8	1-1/4	9-7/8	5-1/2	5/8

TOWING PAD EYE

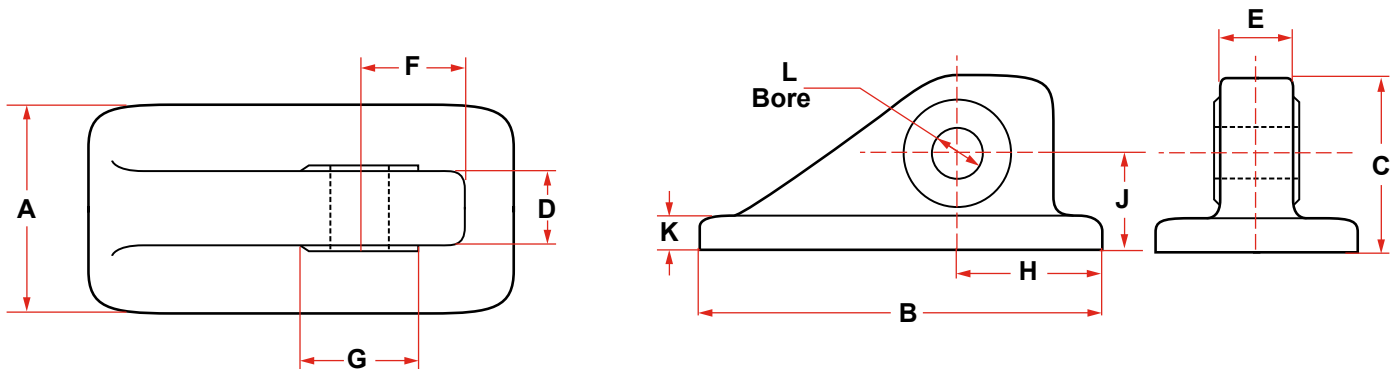

DIMENSIONS (INCHES)											
Chain Size	A	B	C	D	E	F	G	H	J	K	L
3/4	5	10	4-3/4	3/4	1	1-3/4	1-7/8	2-1/4	2-3/4	3/4	15/16
1	5	10	5-1/4	1-3/16	1-7/16	1-3/4	2-3/8	2-3/4	3	3/4	1-3/16
1-1/4	6	12	6	1-17/32	1-25/32	2-1/2	3	3-3/4	3-1/2	1	1-7/16
1-1/2	6	12	6-3/4	1-7/8	2-1/8	3	3-5/8	4-1/2	3-7/8	1	1-11/16
2	8	16	8-1/2	2-3/4	3	4-1/4	5	5-3/4	5	1-1/2	2-5/16
2-1/2	10	20	9-3/4	3-5/8	3-7/8	5	6	8	5-3/4	1-3/4	2-13/16
3	12	24	10-1/2	4-1/2	4-3/4	5-5/8	6-1/2	9	6	2	3-5/16

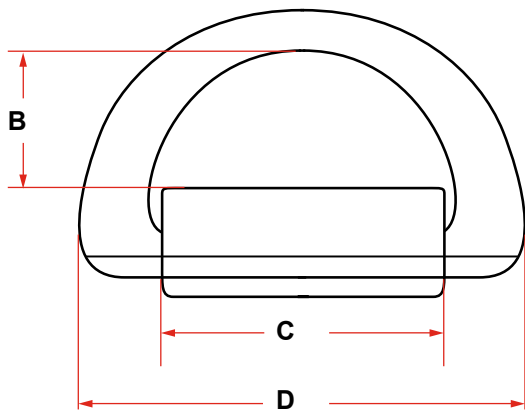

D-RING

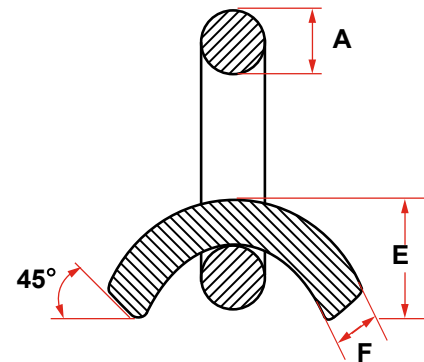

DIMENSIONS (MM)							
Tons	A	B	C	D	E	F	Weight (Kg)
7	12.7	44.5	60.3	95.3	22.4	6.5	.45
36	22	66	125	208	36	12	2.4
41	23	79.4	127	203.2	44.5	12.7	3.5
50	25.4	67.2	127	222.3	51.9	16	4.7

CAST STEEL D-RING

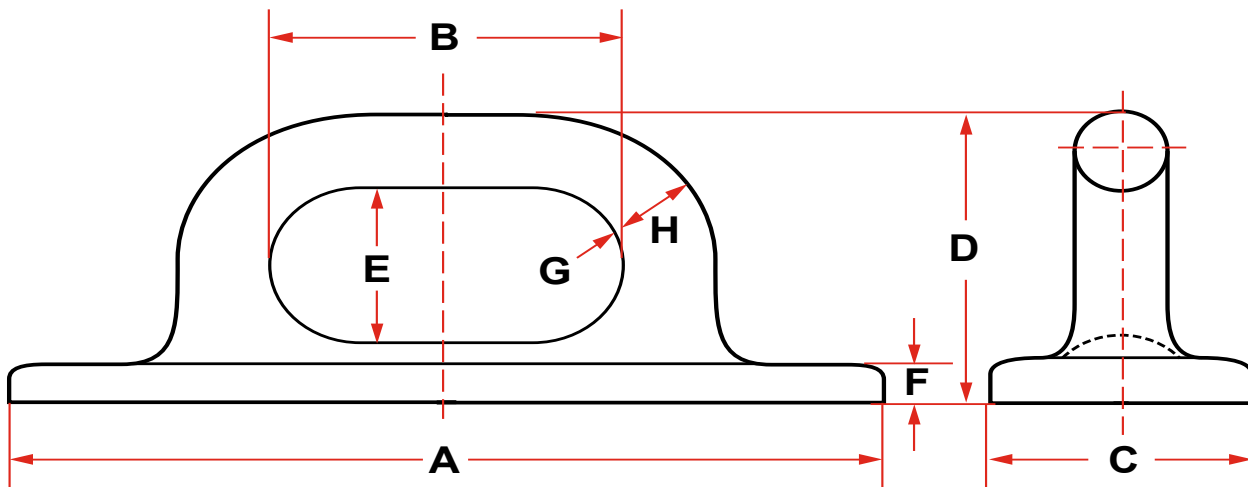

MODEL NO.	A	B	C	D	E	F	G	H	WEIGHT (LBS)
DF-196	20	8	6	7-5/8	4	1	2	2-1/8	55



CASTING INDEX

PART NUMBER	DESCRIPTION	ANCHOR BOLTS QTY. X SIZE	MAXIMUM CAPACITY
AMB-20	BOLLARD, CAST STEEL	4 X 1-3/4"	20 TONS
AMB-25	BOLLARD, CAST STEEL	4 X 2-1/4"	25 TONS
AMB-30	BOLLARD, CAST STEEL	6 X 1-3/4"	30 TONS
AMB-40	BOLLARD, CAST STEEL	8 X 1-1/2"	40 TONS
AMB-40A	BOLLARD, CAST STEEL	4 X 1-1/2"	40 TONS
AMB-45	BOLLARD, CAST STEEL	4 X 1-1/4"	45 TONS
AMB-50A	BOLLARD, CAST STEEL	4 X 1-1/4"	50 TONS
AMB-50	BOLLARD, CAST STEEL	4 X 1-3/4"	50 TONS
AMB-55	BOLLARD, CAST STEEL	4 X 1-3/4"	55 TONS
AMB-65	BOLLARD, CAST STEEL	4 X 1-3/4"	65 TONS
AMB-70	BOLLARD, CAST STEEL	4 X 2"	70 TONS
AMB-80	BOLLARD, CAST STEEL	4 X 2"	80 TONS
AMB-90	BOLLARD, CAST STEEL	6 X 2"	90 TONS
AMB-100	BOLLARD, CAST STEEL	6 X 2-1/4"	100 TONS
AMB-100A	BOLLARD, CAST STEEL	8 X 2-1/4"	100 TONS
AMB-100B	BOLLARD, CAST STEEL	8 X 2-1/4"	100 TONS
AMB-125	BOLLARD, CAST STEEL	8 X 2"	125 TONS
AMB-150	BOLLARD, CAST STEEL	8 X 2-3/4"	150 TONS
AMB-225	BOLLARD, CAST STEEL	8 X 2-3/4"	225 TONS

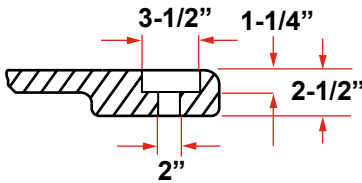
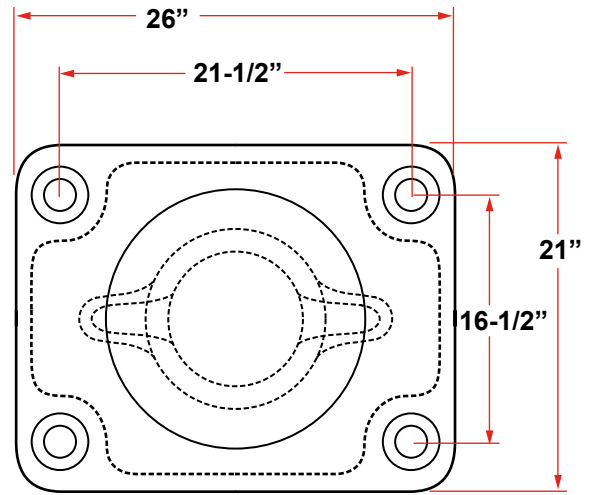
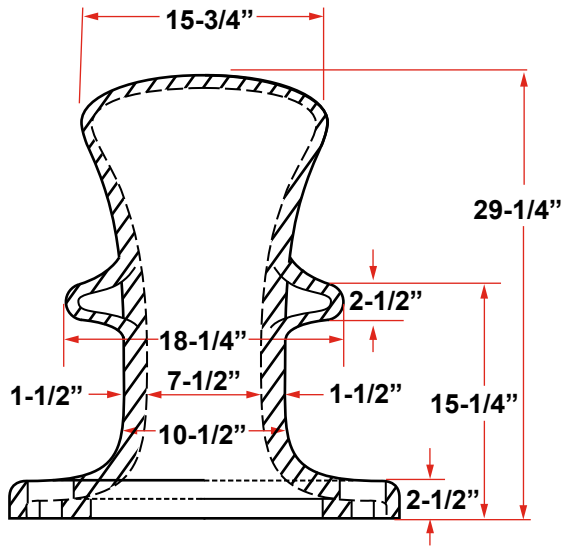

2" Ø CORE FOR
1-3/4" Ø BOLT

20 TON BOLLARD AMB-20

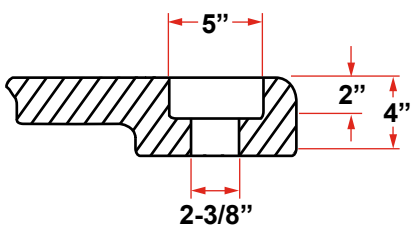
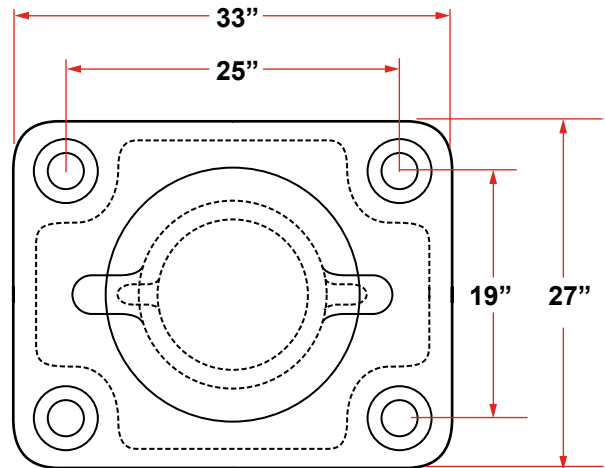
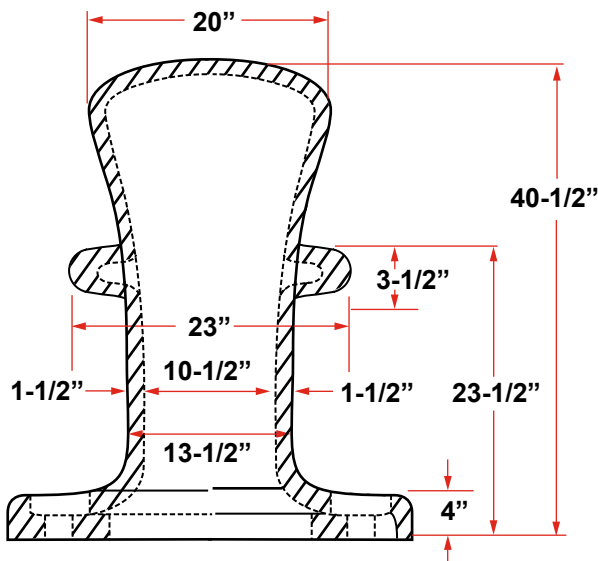

2-3/8" Ø CORE FOR
2-1/4" Ø BOLT

25 TON BOLLARD AMB-25

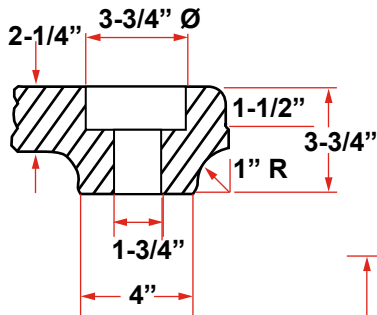
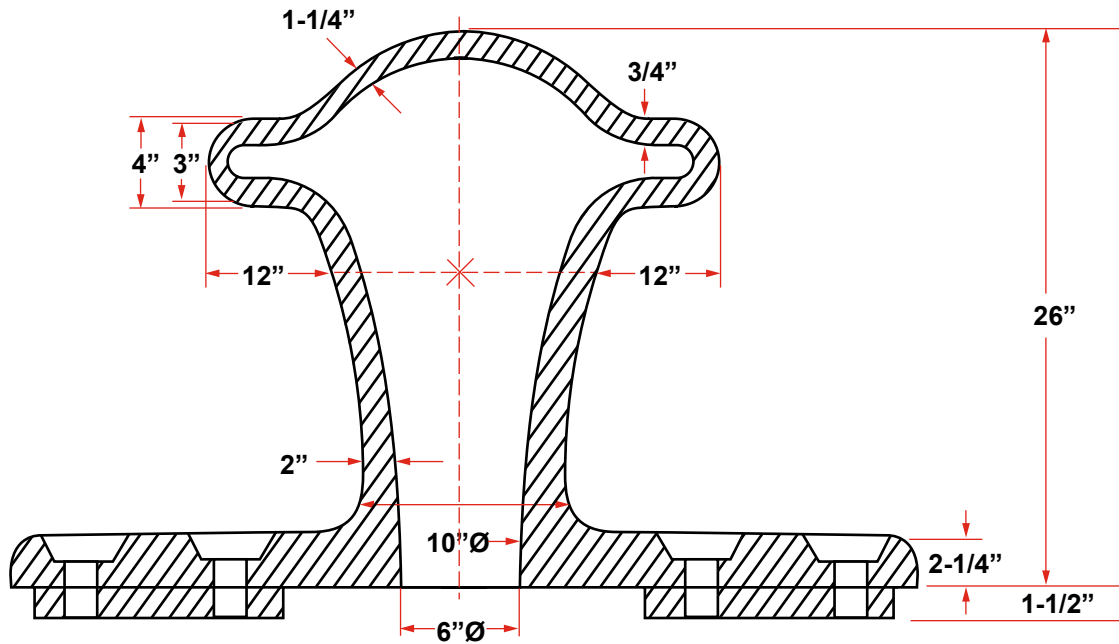

1-3/4" Ø CORE FOR
1-1/2" Ø BOLT

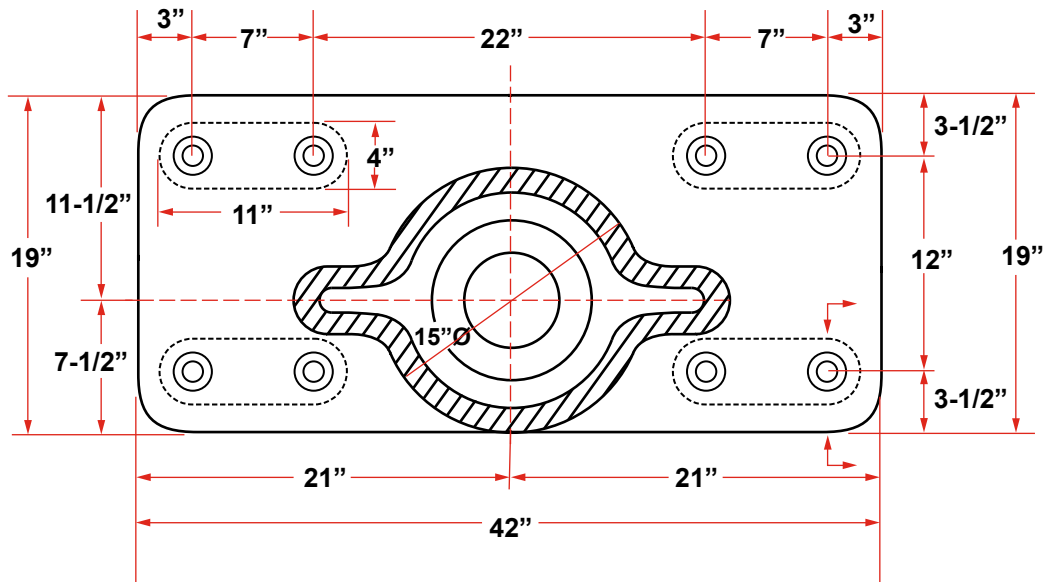
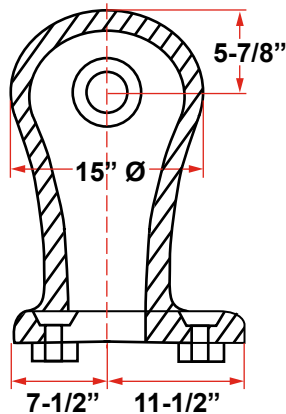

**40 TON BOLLARD
AMB-40**

40 TON BOLLARD AMB-40A

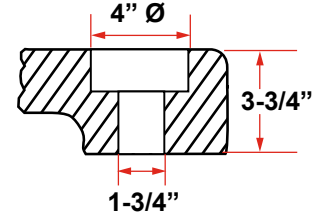
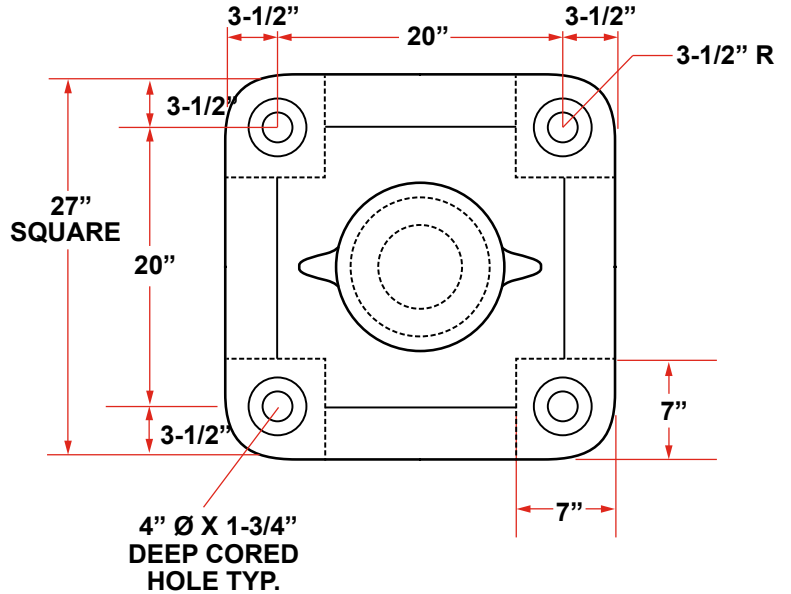
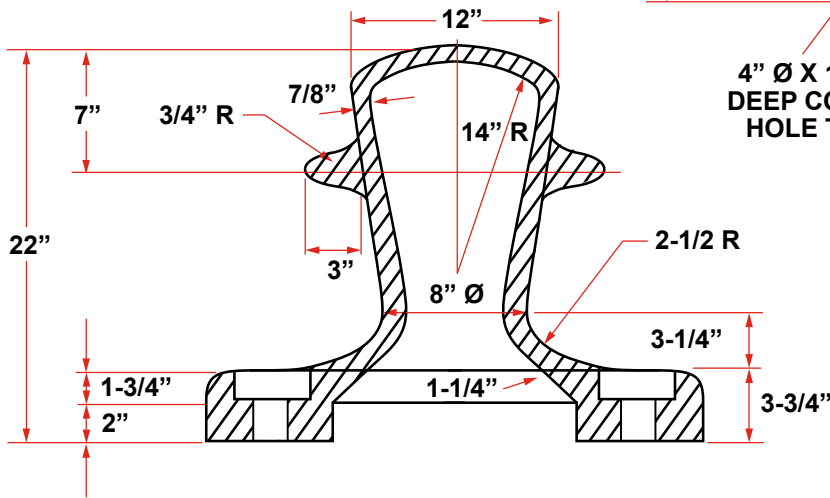

1-3/4" Ø CORE FOR
1-1/2" Ø BOLT

45 TON BOLLARD AMB-45

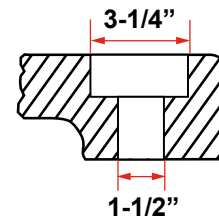
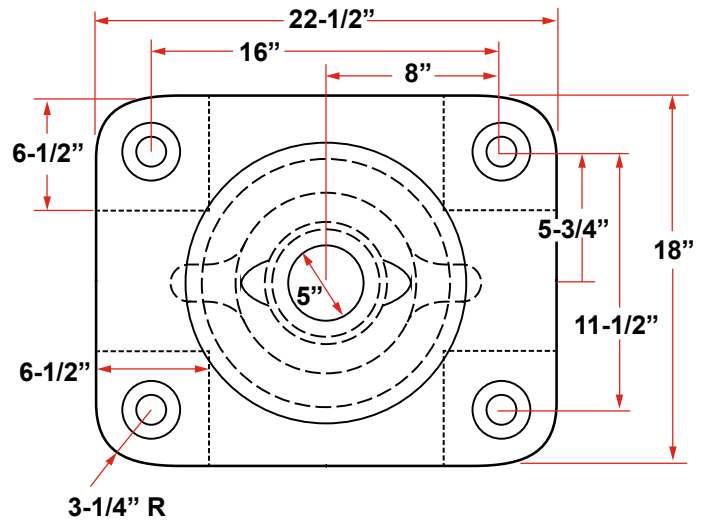
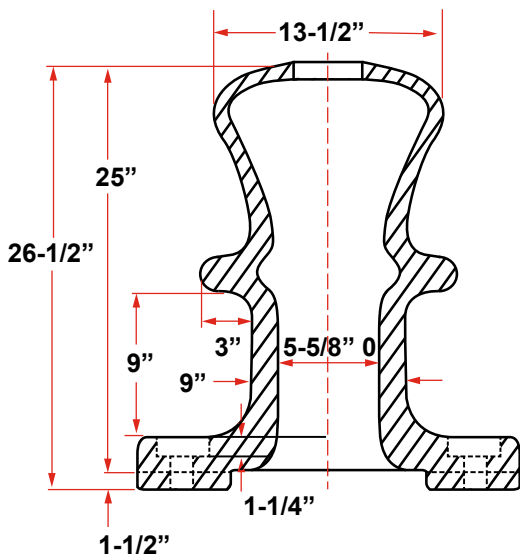

1-1/2" Ø CORE FOR
1-1/4" Ø BOLT

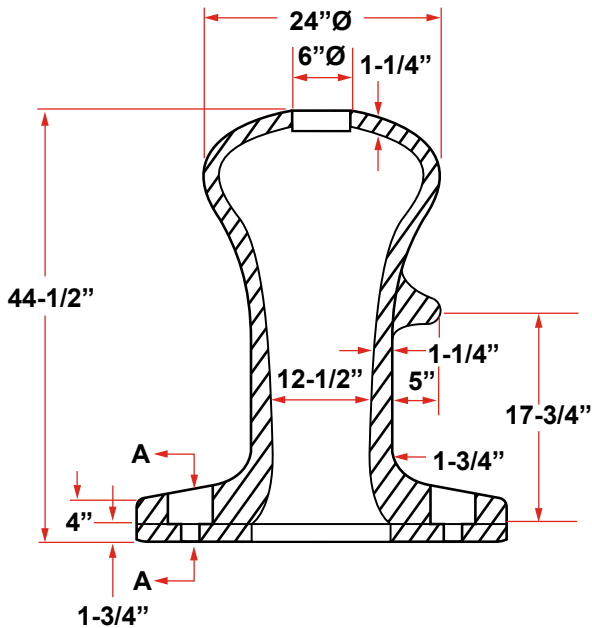

2" Ø CORE FOR
1-3/4" Ø BOLT

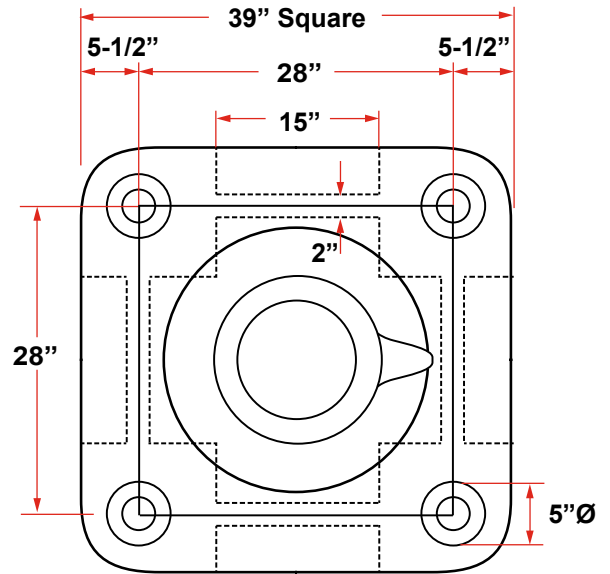
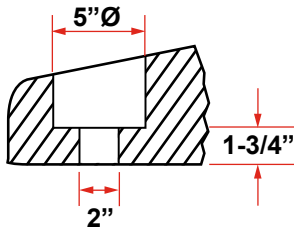

50 TON BOLLARD AMB-50

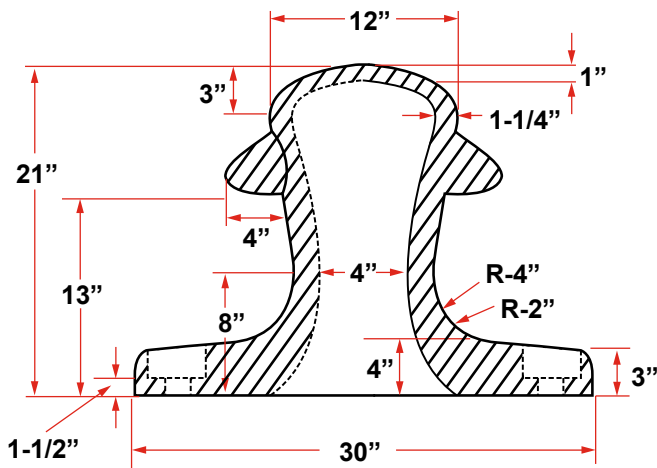

1-1/2" Ø CORE FOR
1-1/4" Ø BOLT

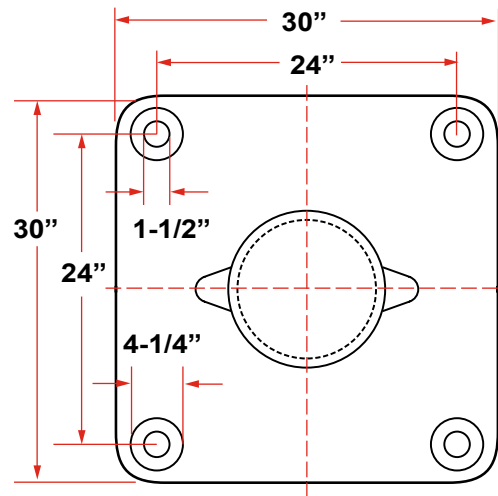
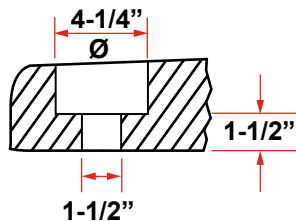

50 TON BOLLARD AMB-50A

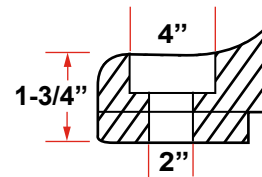
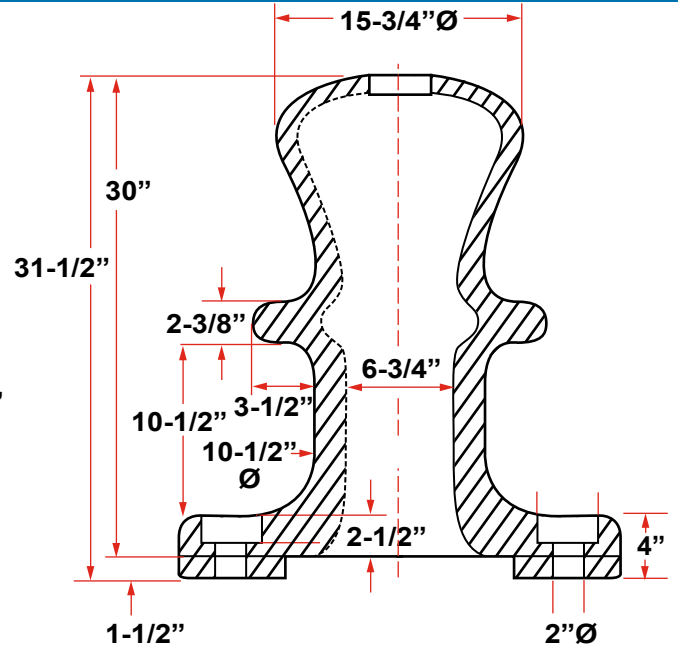
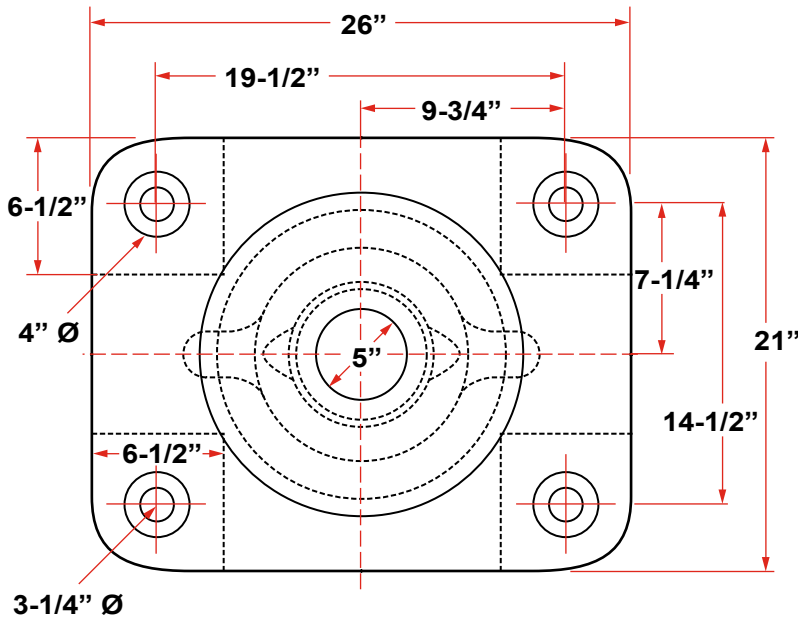

2" Ø CORE FOR
1-3/4" Ø BOLT

55 TON BOLLARD AMB-55

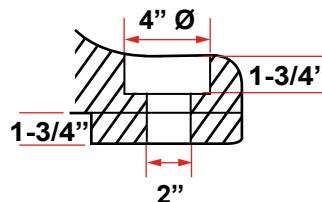
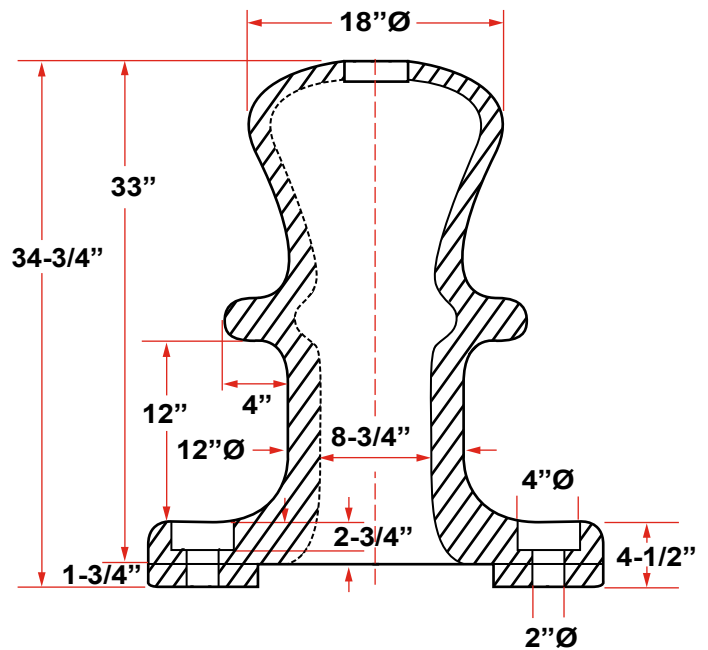
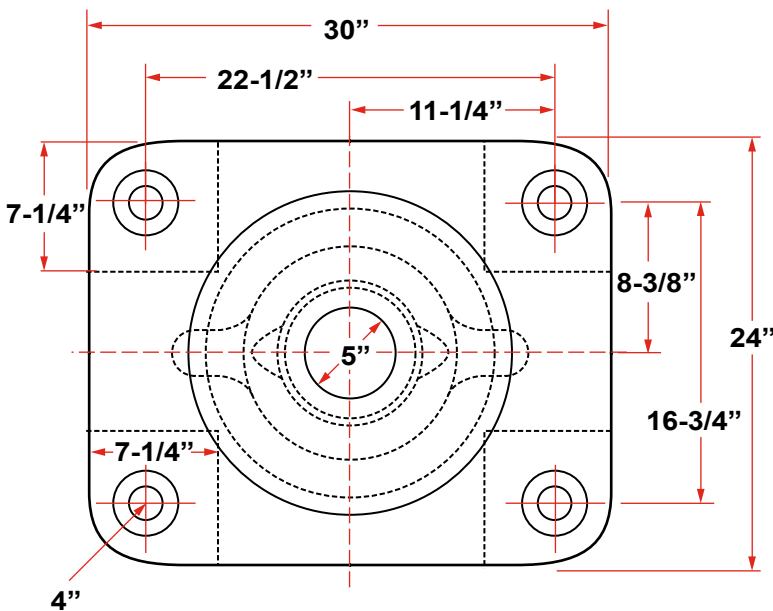

2" Ø CORE FOR
1-3/4" Ø BOLT

65 TON BOLLARD AMB-65

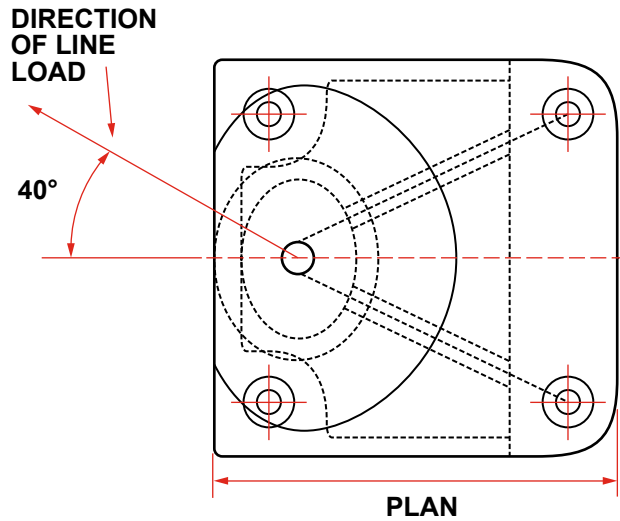
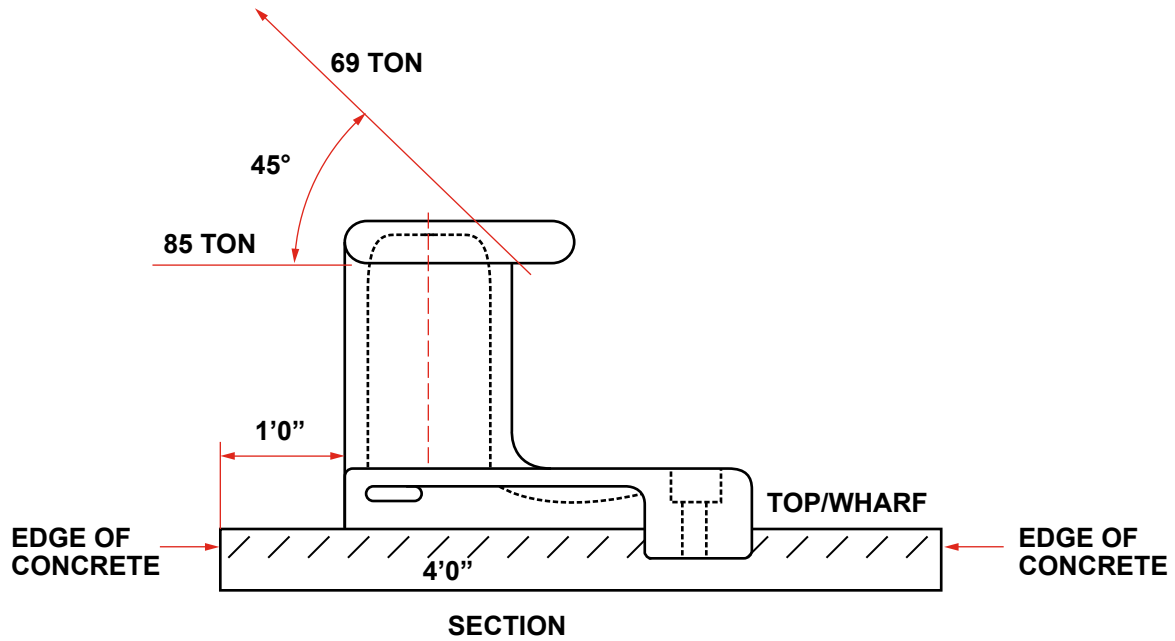

T-HEAD BOLLARD MOORING LINE LOAD

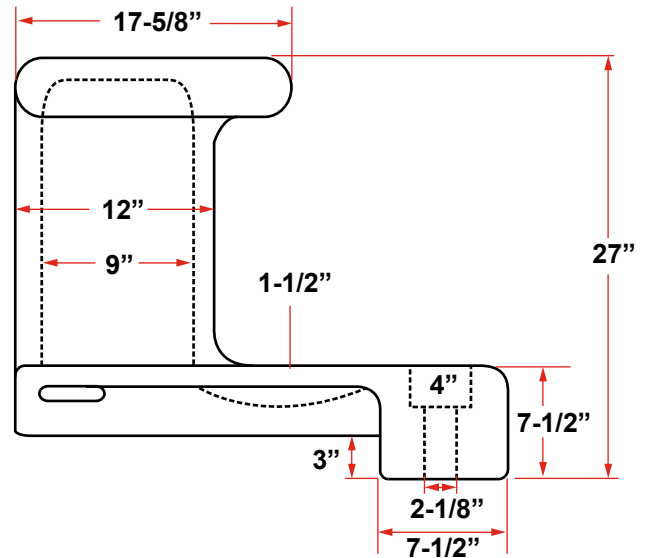
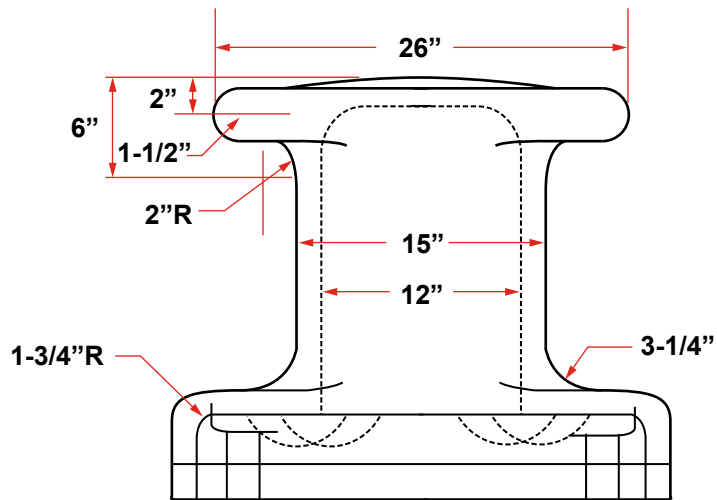
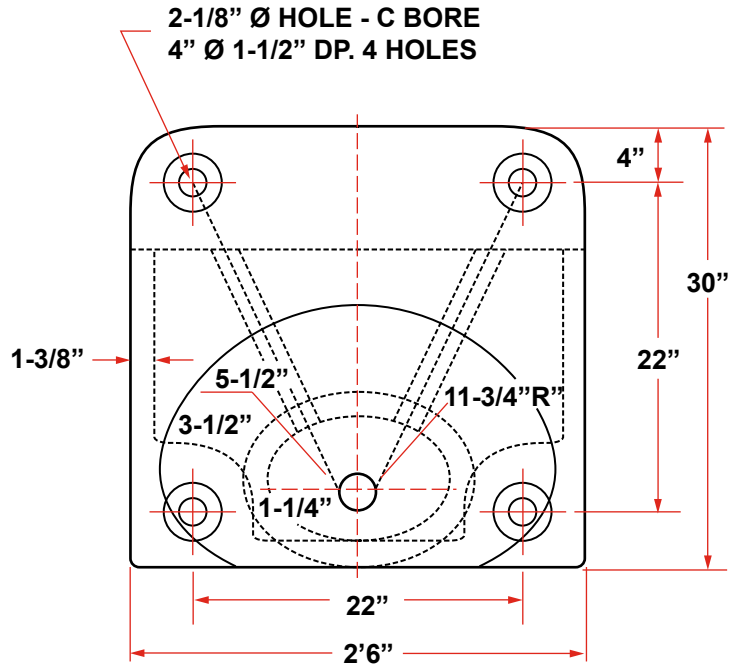

2 1/8" Ø CORE FOR
2" Ø BOLTS

**70 TON BOLLARD
AMB-70**

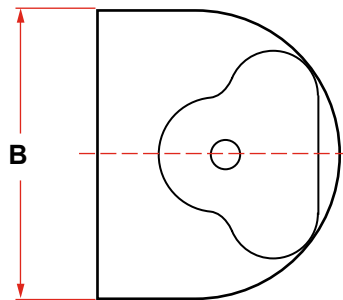
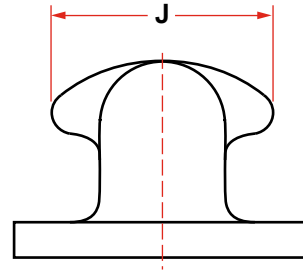
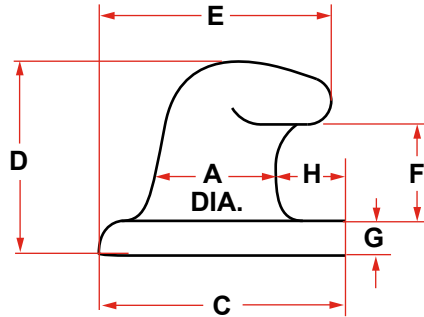

T-HEAD BOLLARD MOORING BOLLARD

APPROXIMATE DIMENSIONS (INCHES)										
Load Tons	Type No.	A	B	C	D	E	F	G	H	J
50	X-5-A	11-3/4	31-1/2	25-1/2	19	22-1/2	9-1/2	3	8	23-1/2
75	X-9-A	13-1/2	31-1/2	28-1/4	20	24-1/4	10-1/4	3-1/2	8-3/4	25-1/2
100	X-10-A	14-3/4	39-1/4	32	23-1/2	28	12	4	10-3/4	29-1/2
150	X-15-A	17	42-1/2	35-1/2	26-1/4	32-3/4	13-3/4	4-3/8	11	31-1/2

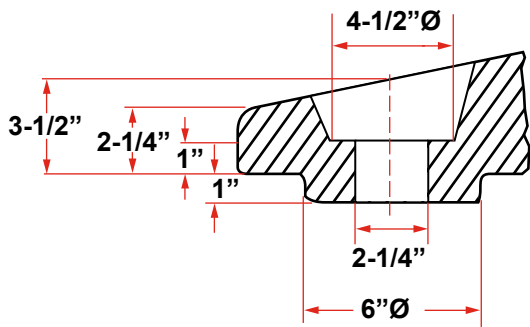
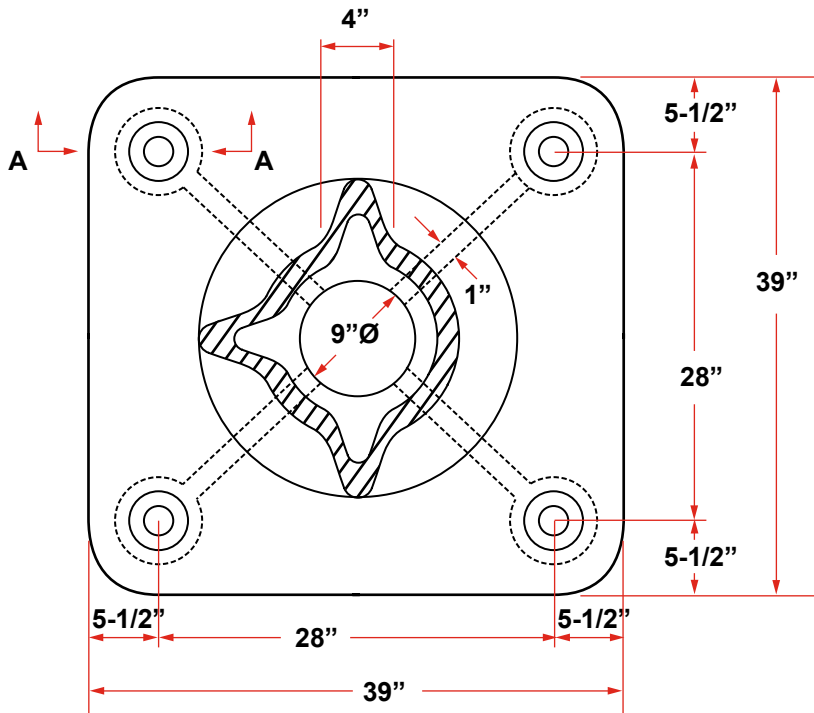

2-1/4" CORE HOLES FOR
2" Ø BOLTS

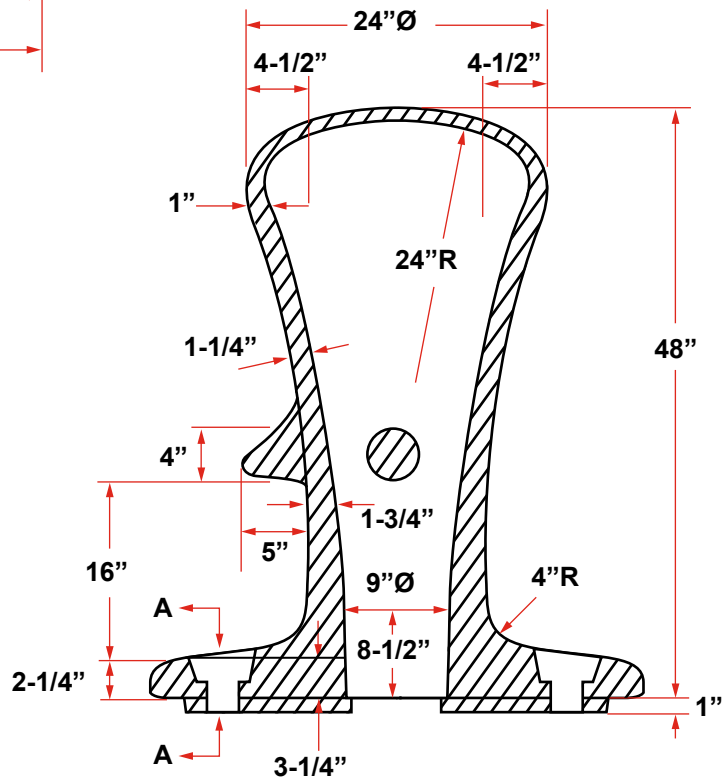

80 TON BOLLARD AMB-80

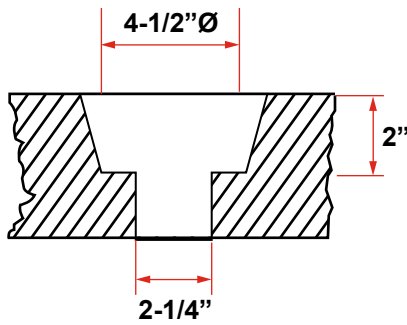

2-1/4" Ø CORE FOR
2" Ø BOLT

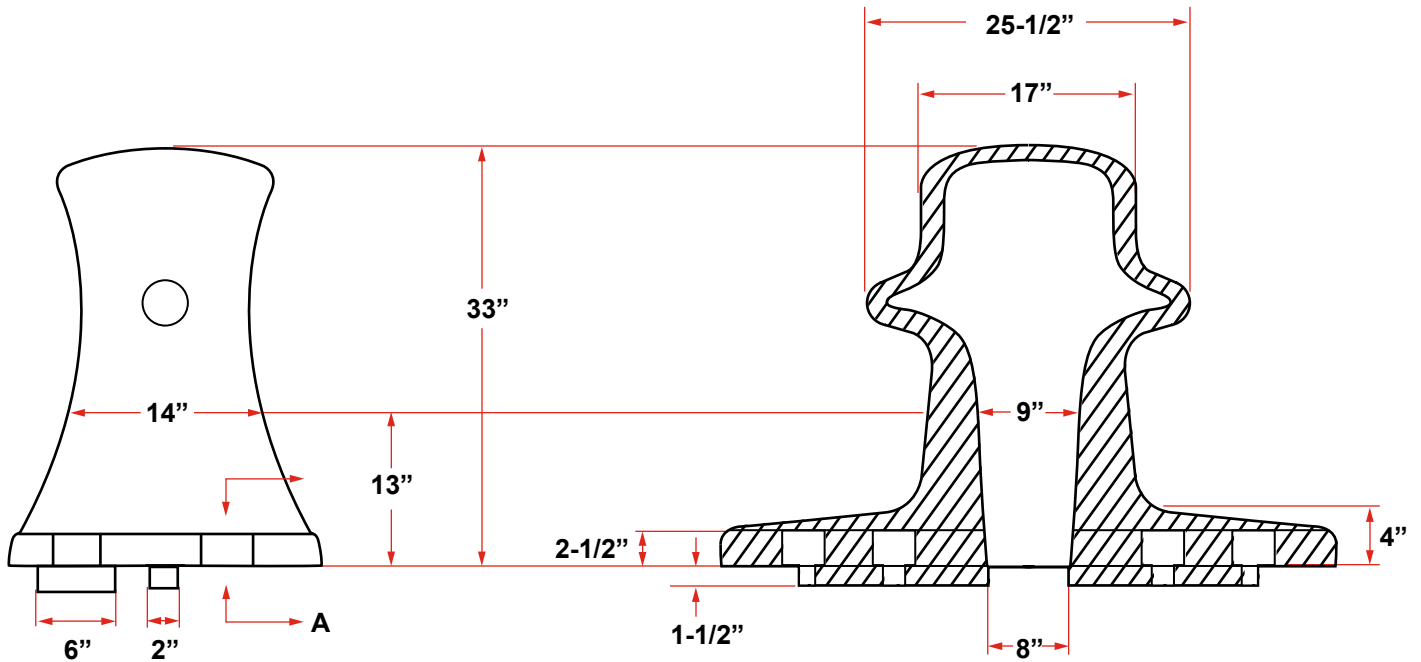
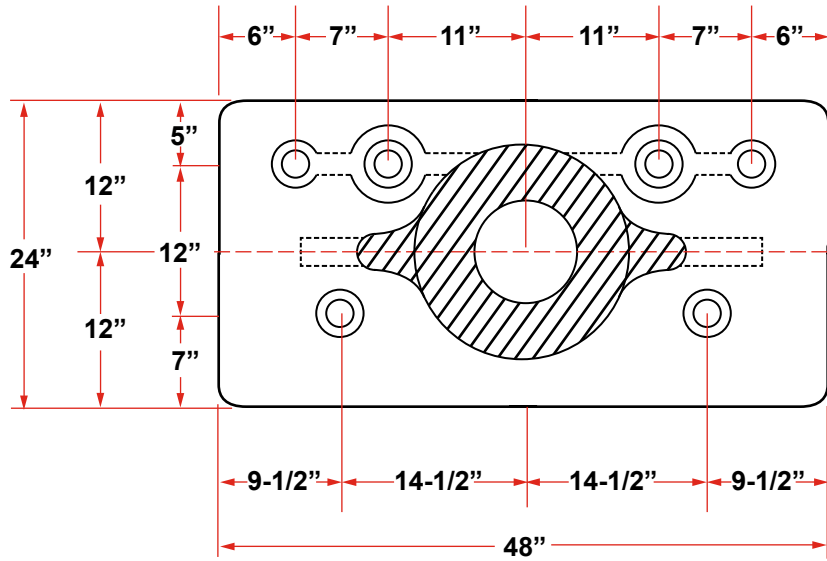

**90 TON BOLLARD
AMB-90**

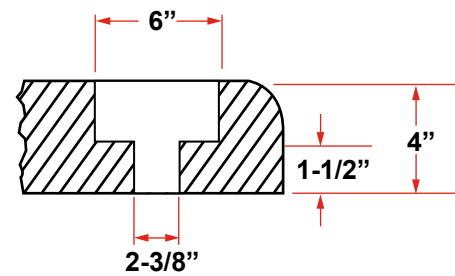
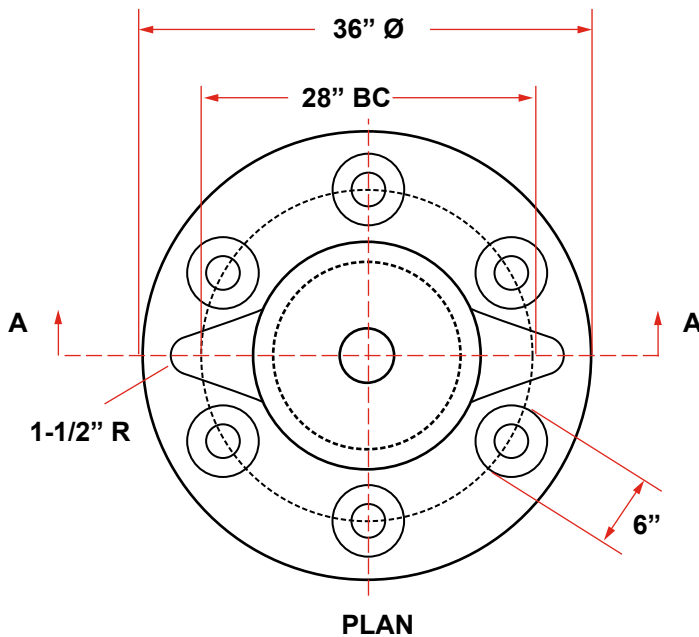
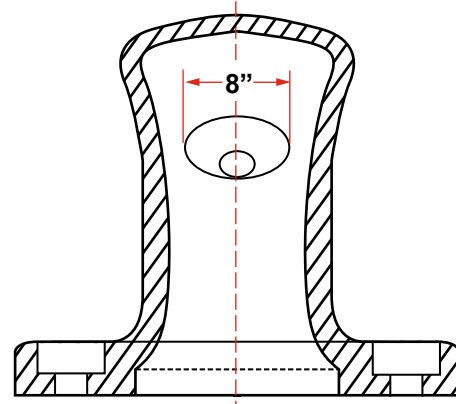
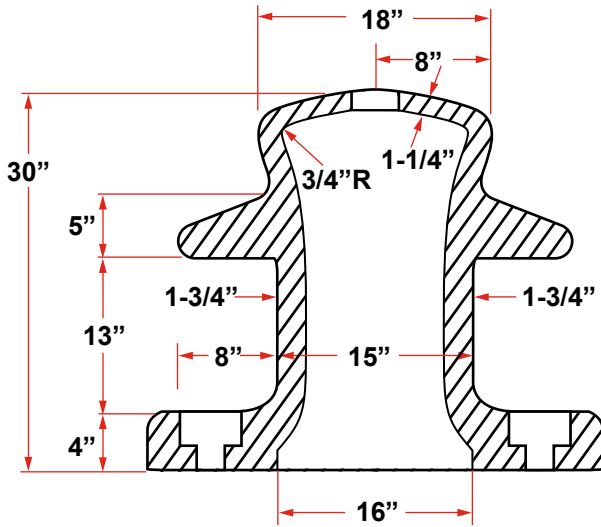

**2-3/8" Ø CORE FOR
2-1/4" Ø BOLT**

100 TON BOLLARD AMB-100

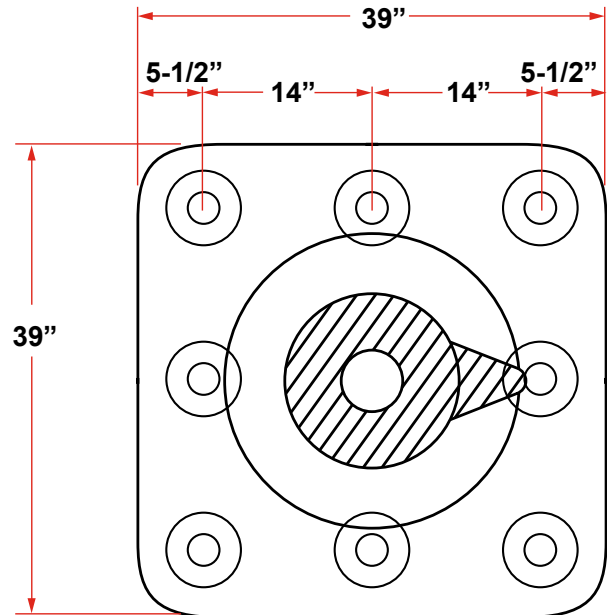
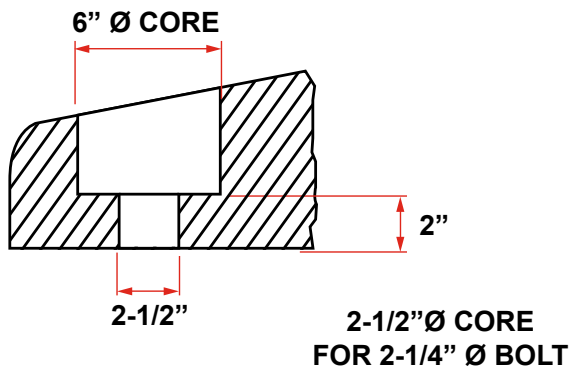
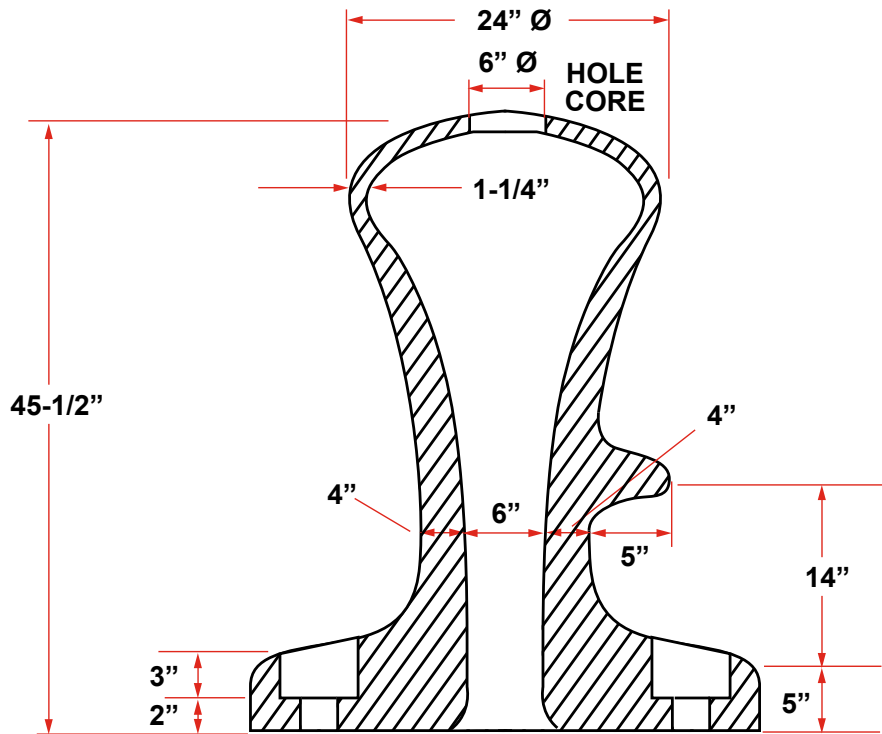

**100 TON BOLLARD
AMB-100A**

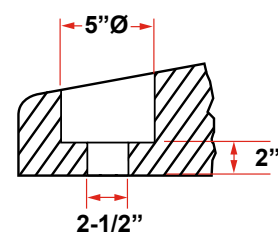
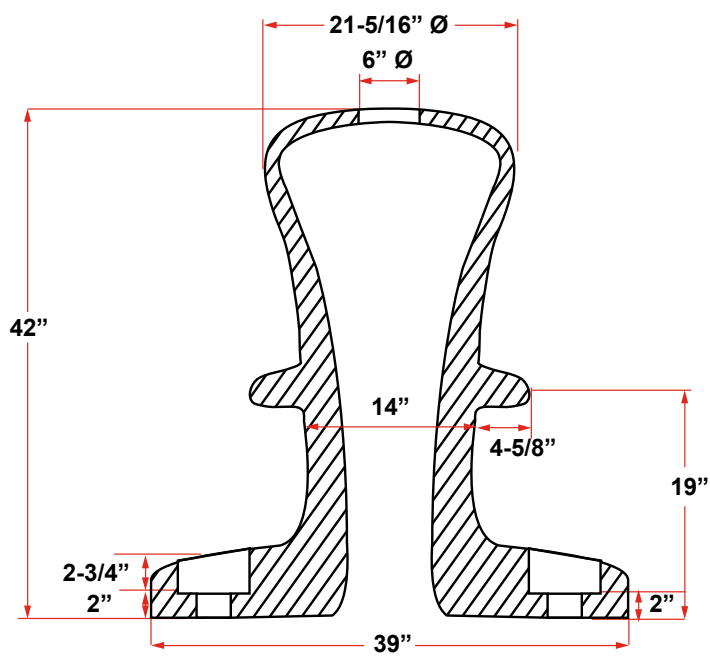
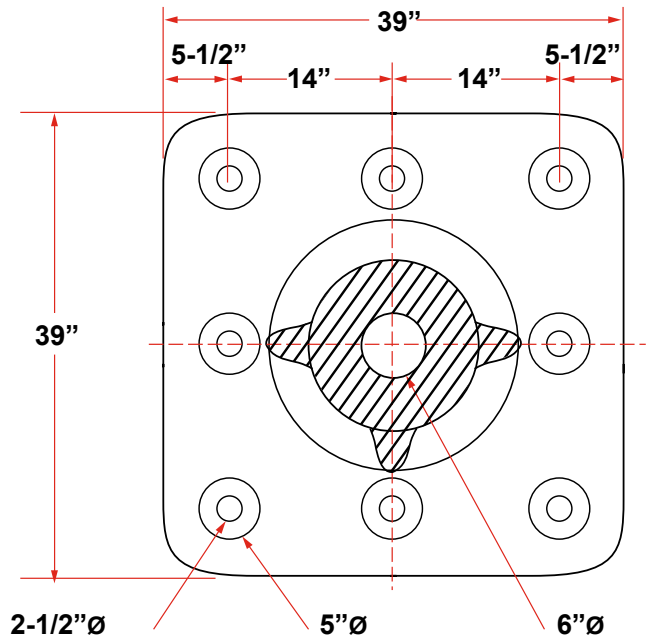

2 1/2" Ø CORE FOR
2-1/4" Ø BOLT

**100 TON BOLLARD
AMB-100B**

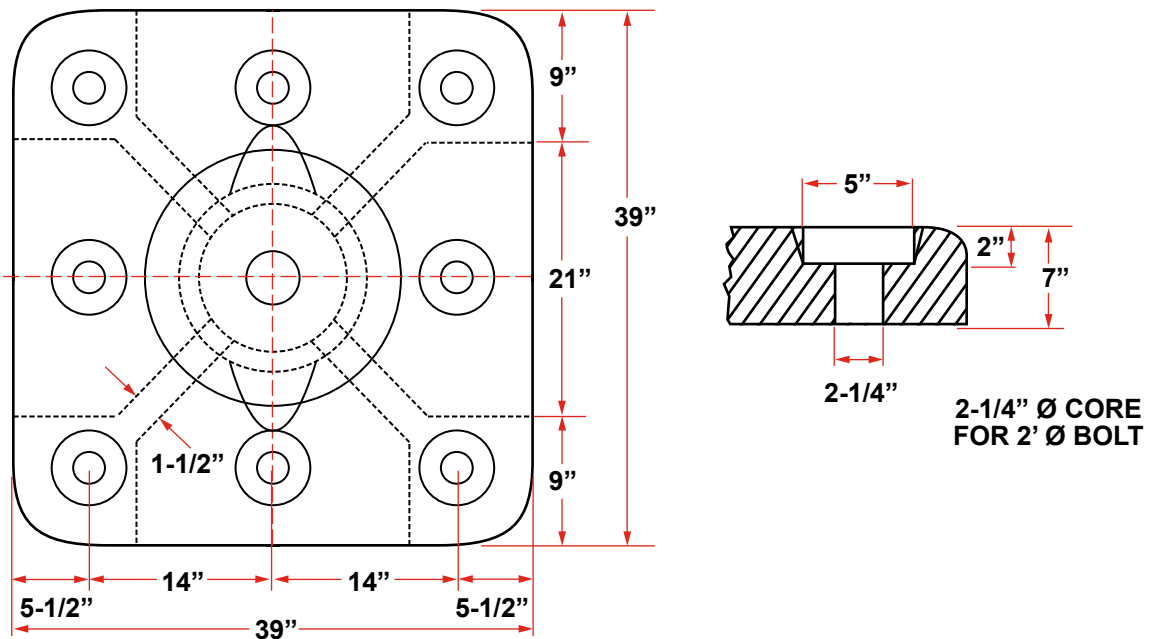
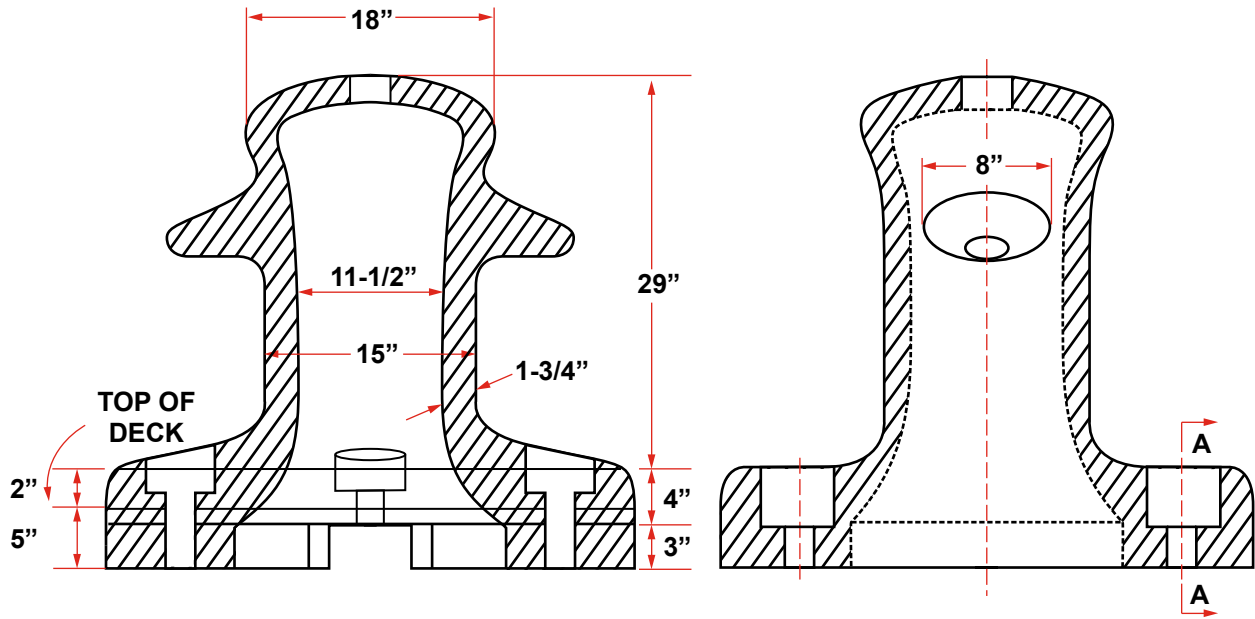

125 TON BOLLARD AMB-125

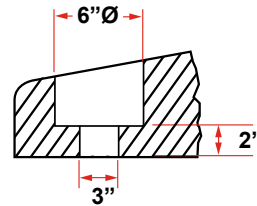
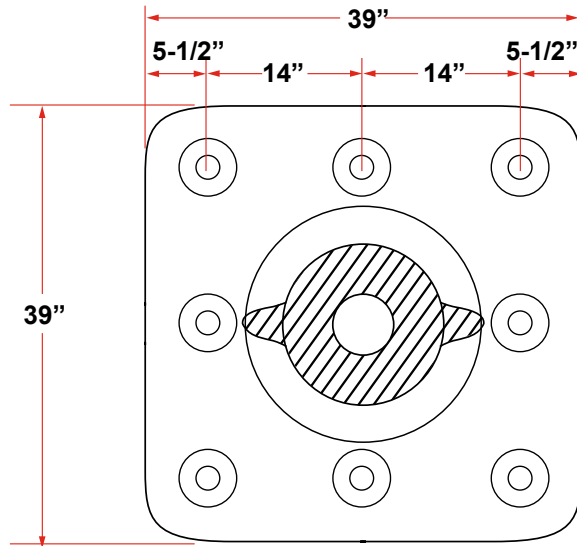

3" Ø CORE FOR
2-3/4" Ø BOLT

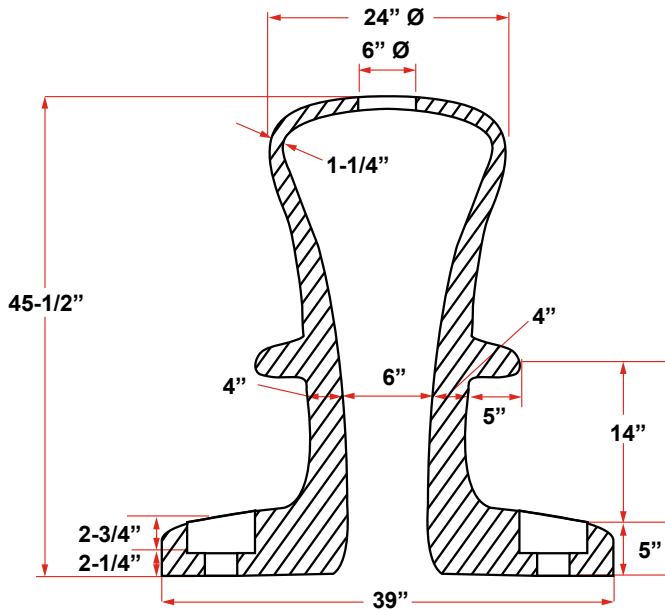

150 TON BOLLARD AMB-150

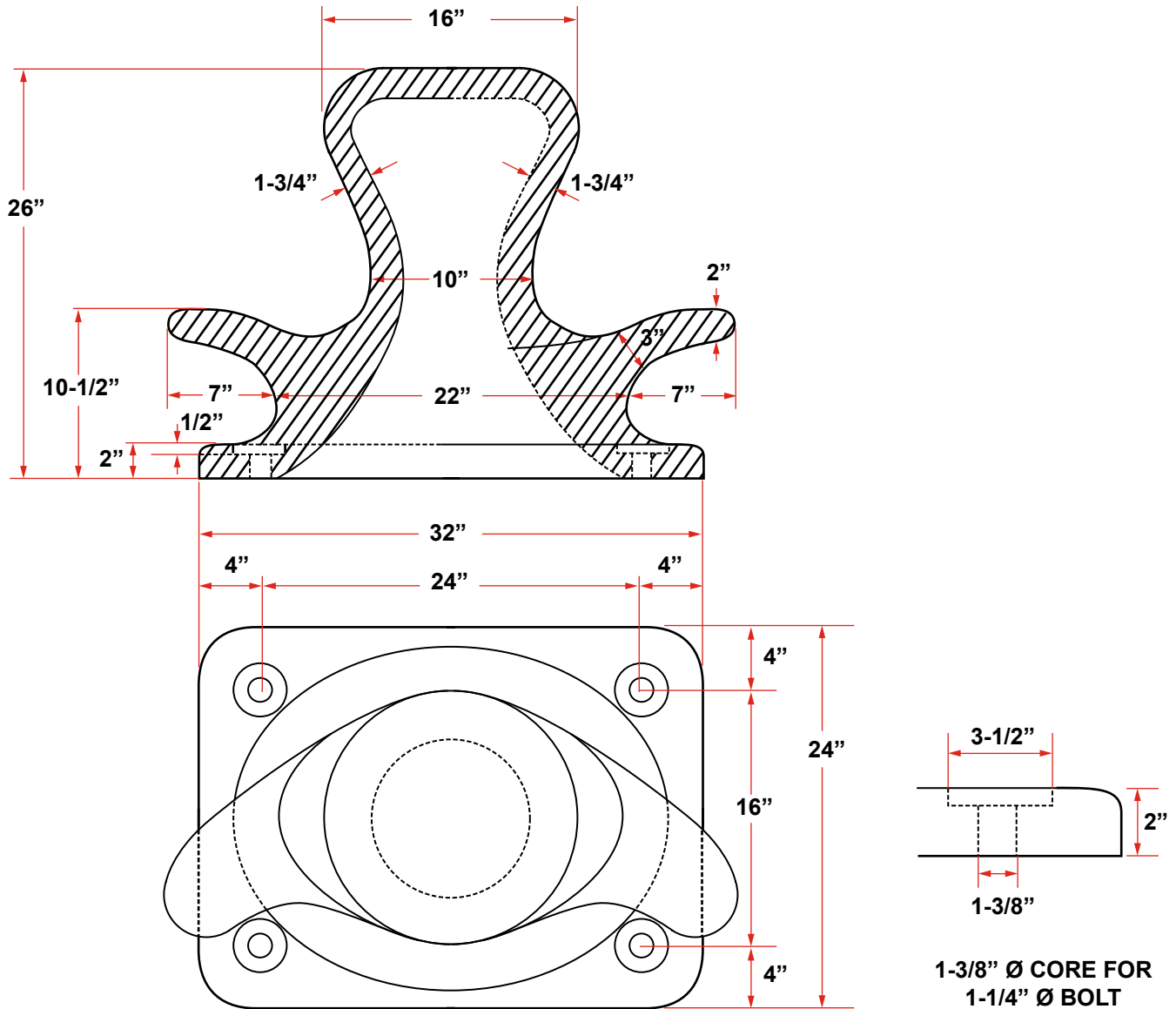

MOORING BITT MB-10.2432

QUICK RELEASE BUOY HOOK
WITH ABS CERTIFICATION

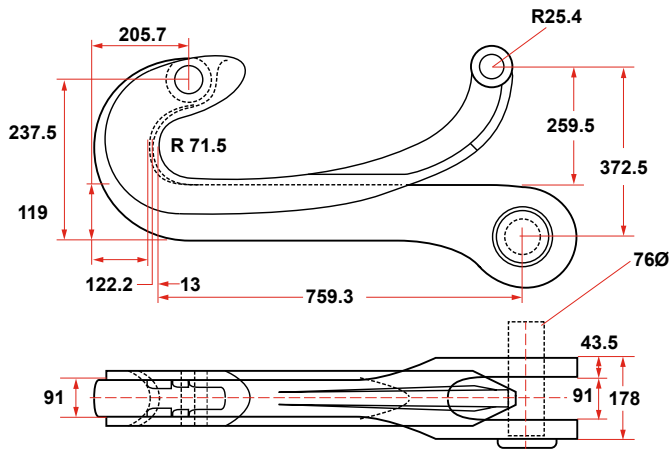

300,000 LBS PROOF LOAD
WEIGHT: 357 LBS

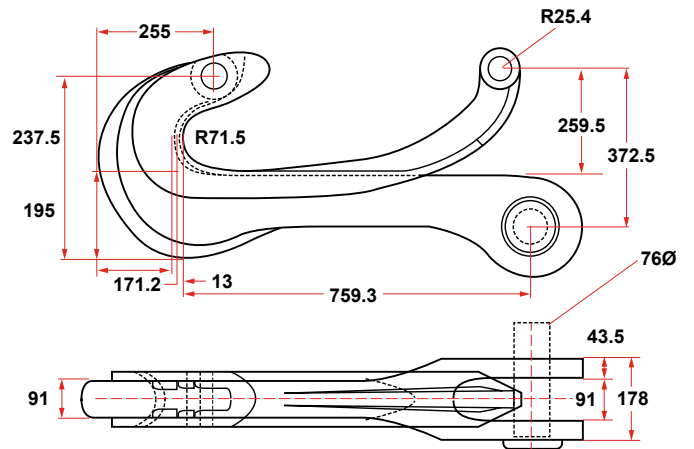

400,000 LBS PROOF LOAD
WEIGHT: 410 LBS

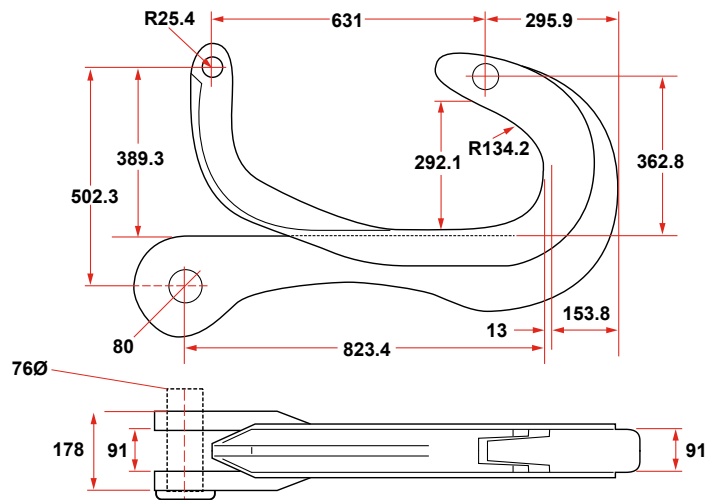

400,000 LBS PROOF LOAD WIDEMOUTH
WEIGHT: 502 LBS

SEA-LINK MOORING SHACKLES

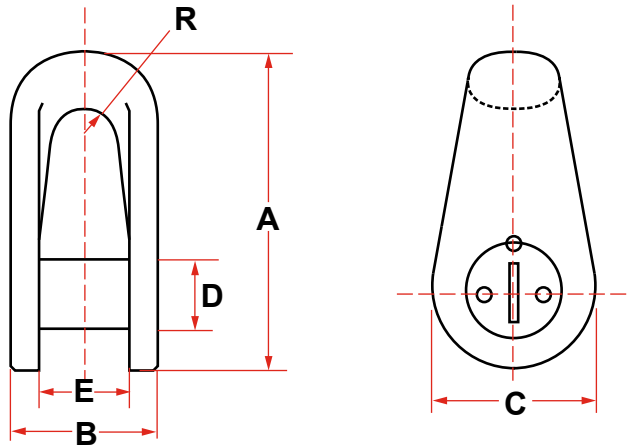

TONSBERG TYPE (PIN STYLE)

MODEL	90T	120T	180T
Forerunner Circ. (inches)	7-9	9-11	11-15
A (mm)	285	324	350
B (mm)	115	142	184
C (mm)	136	150	160
D (mm)	65	75	85
E (mm)	75	90	120
R (mm)	22	28	30
Breaking Load (M. Tons)	90	120	180
Proof Load (M. Tons)	55	70	95
Safe Working Load (M. Tons)	30	40	60
Weight	11.2 KG (25 Lbs)	16.9 KG (37 Lbs)	25 KG (55 Lbs)

MANDAL TYPE (ROLLER STYLE)

MODEL	90M	120M
Forerunner Circ. (inches)	6-9	9-11
A (mm)	255	310
B (mm)	97	121
C (mm)	120	130
D (mm)	65	82
E (mm)	67	90
F (mm)	100	128
R (mm)	34	45
Breaking Load (M. Tons)	90	120
Proof Load (M. Tons)	55	70
Safe Working Load (M. Tons)	30	40
Weight	7.8 KG (17.2 Lbs)	13.3 KG (29 Lbs)

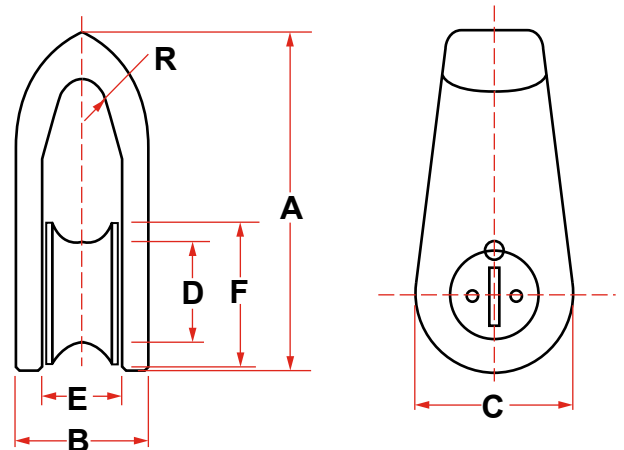

**FACTORY CERTIFICATES INCLUDED
WITH EVERY "SEA-LINK" MOORING
SHACKLE**

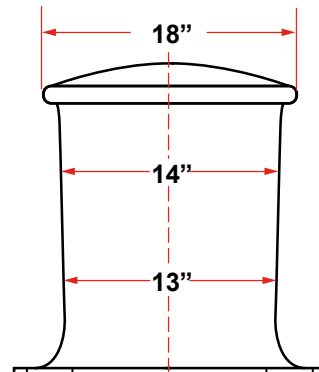
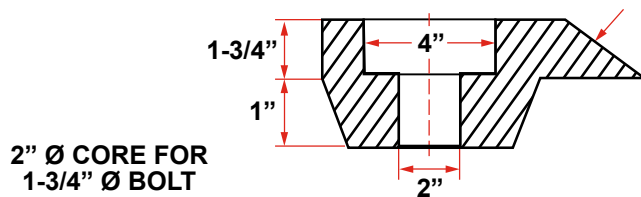
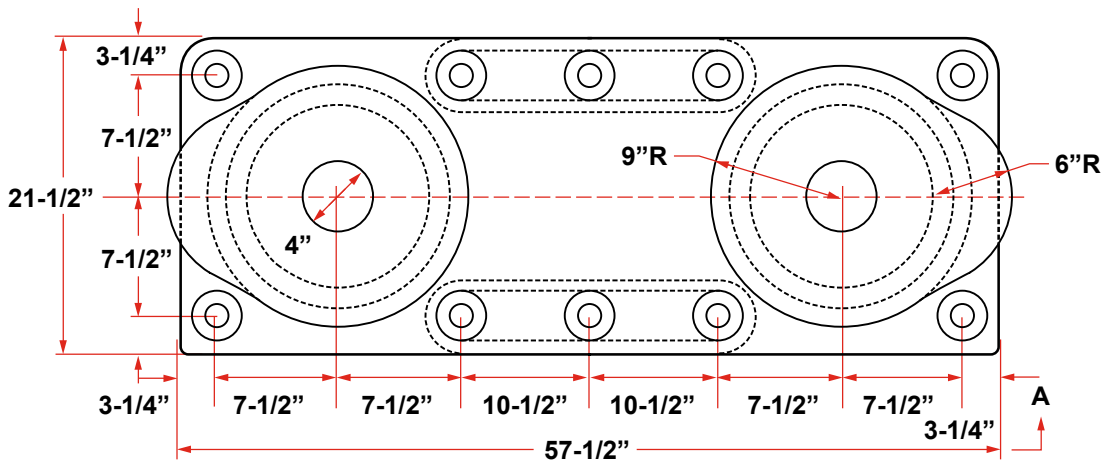
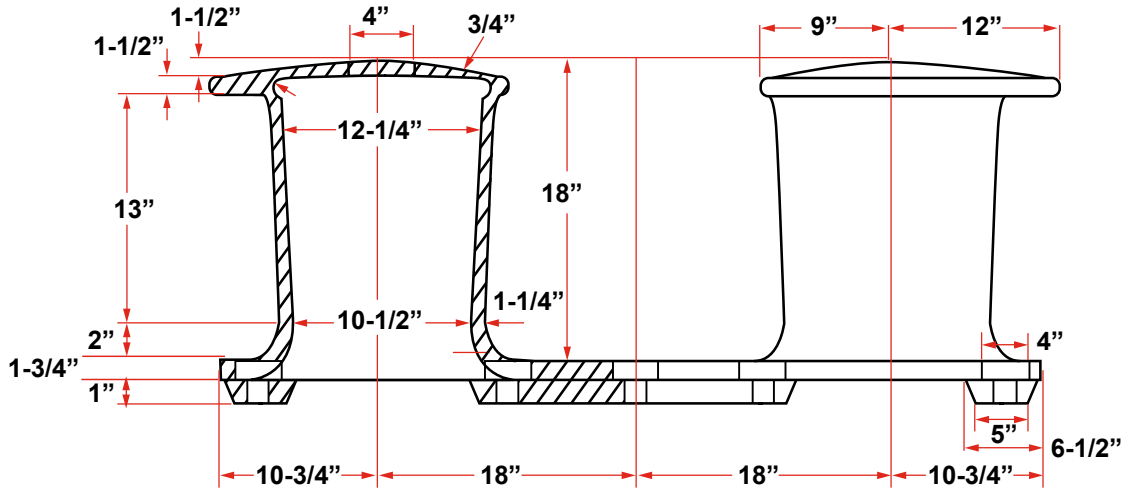

30 TON DOUBLE BITT AMDB-30

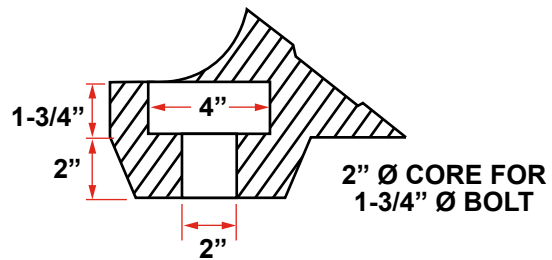
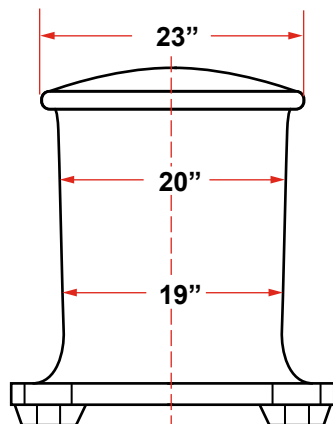
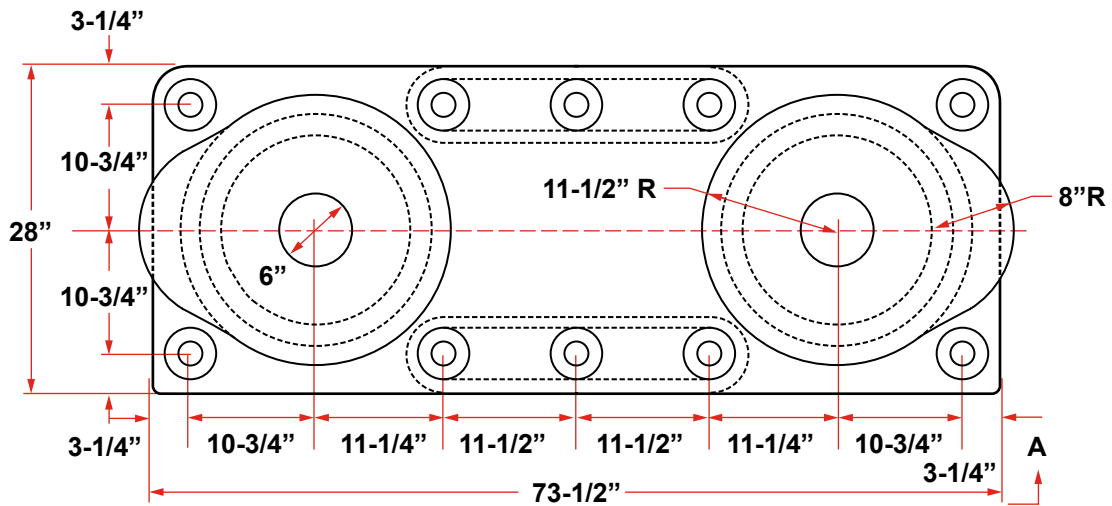
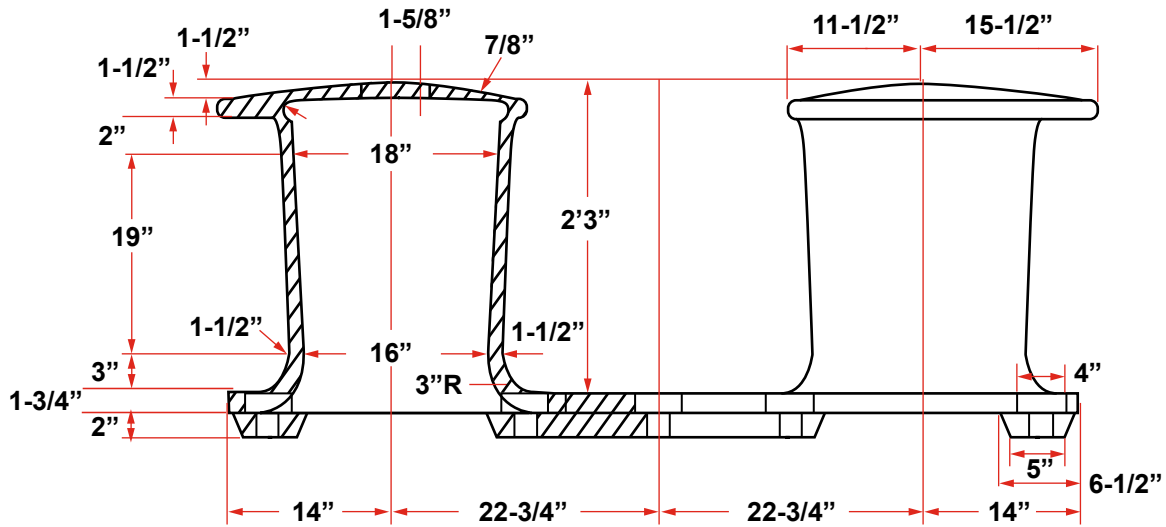

100 TON DOUBLE BITT AMDB-100

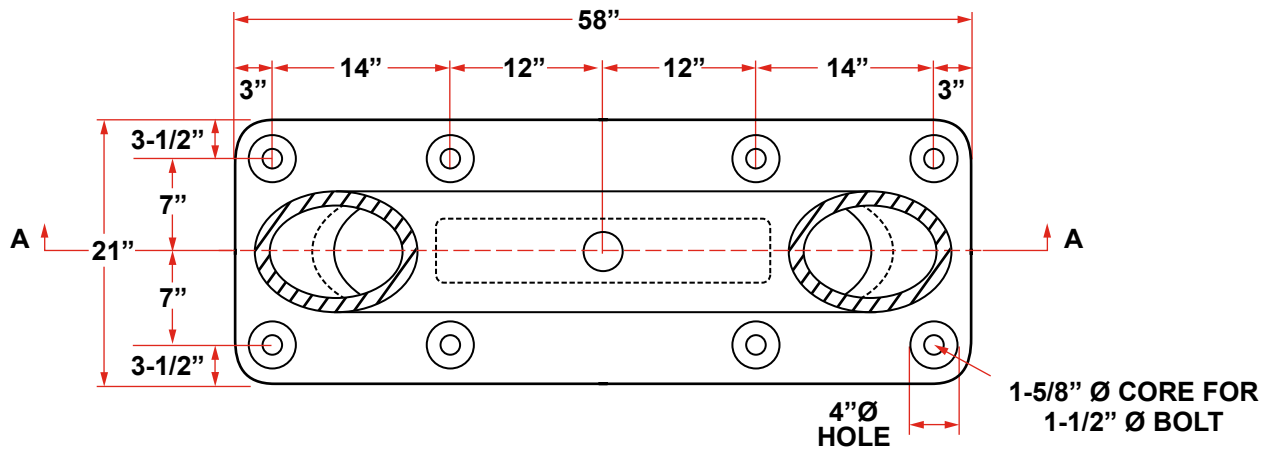
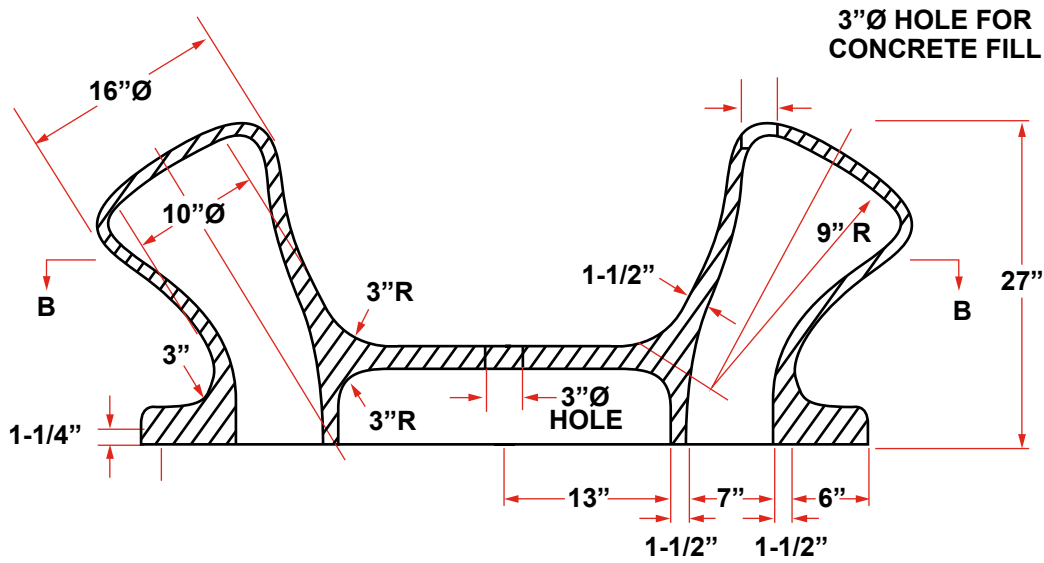

100 TON DOUBLE BITT AMDB-100-58

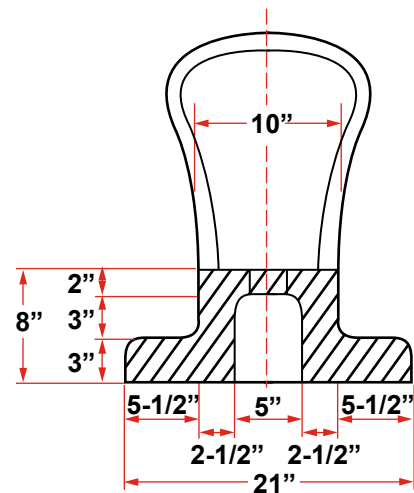

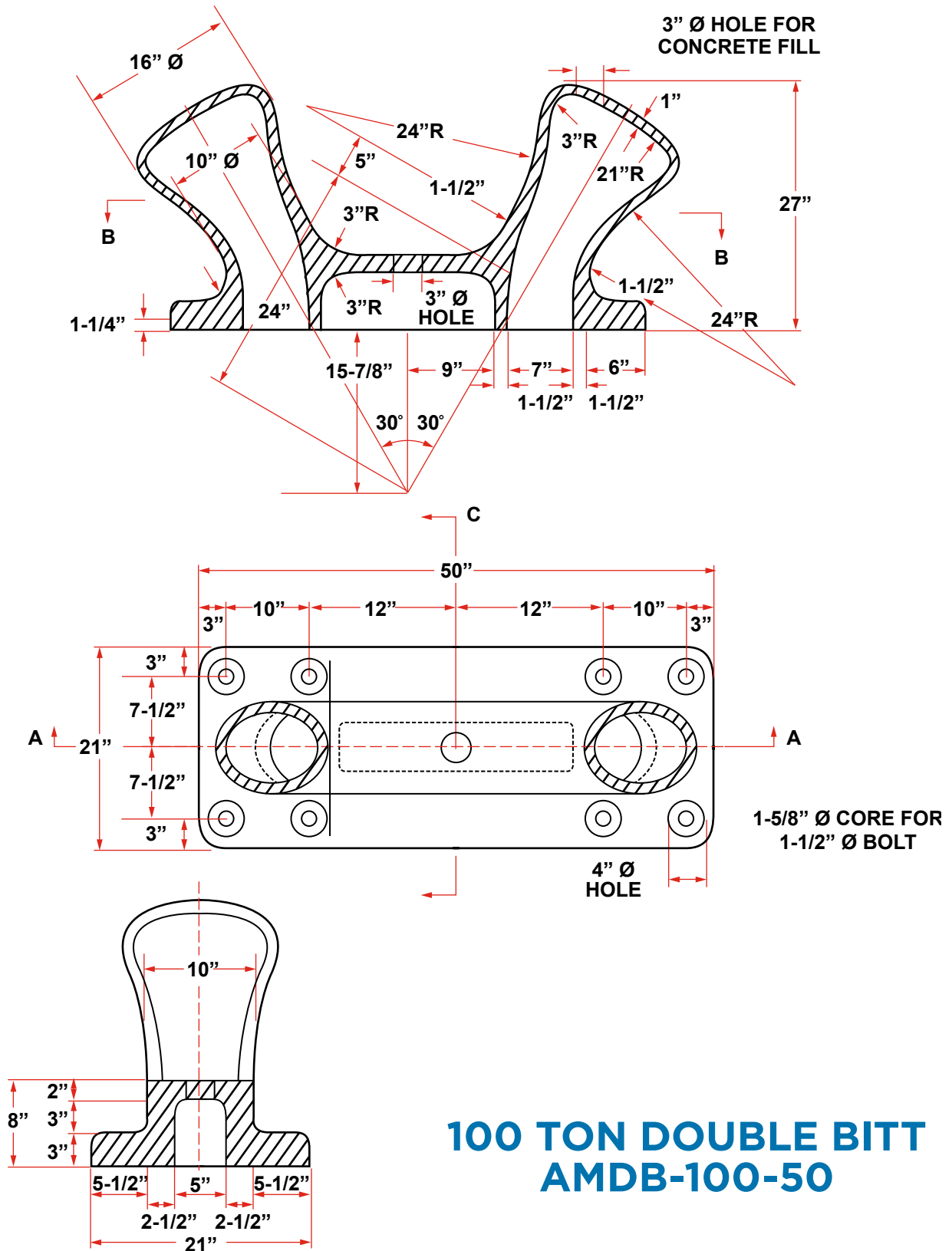

**100 TON DOUBLE BITT
AMDB-100-50**

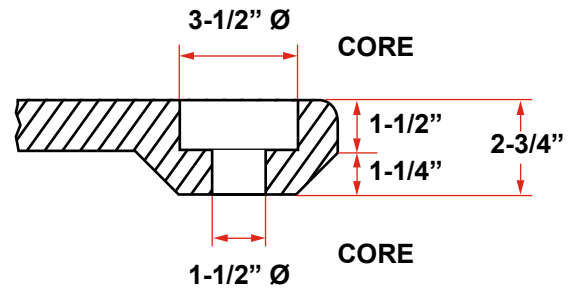
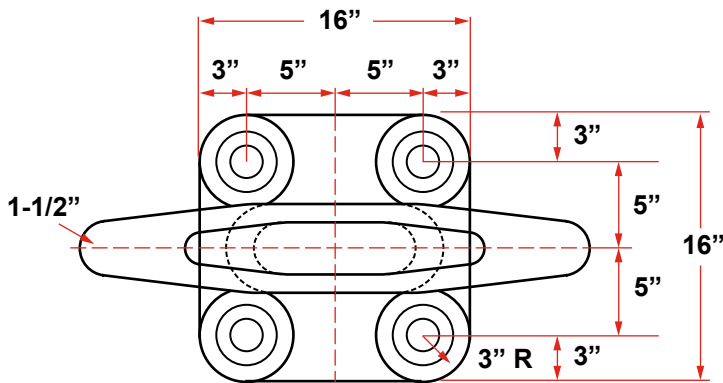
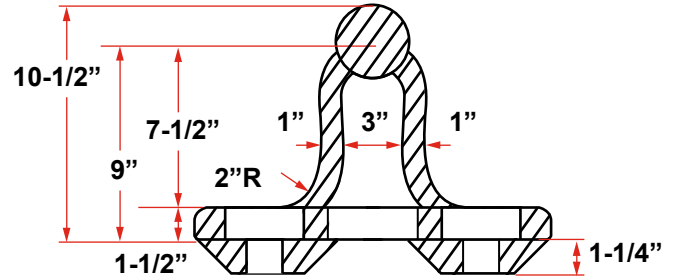
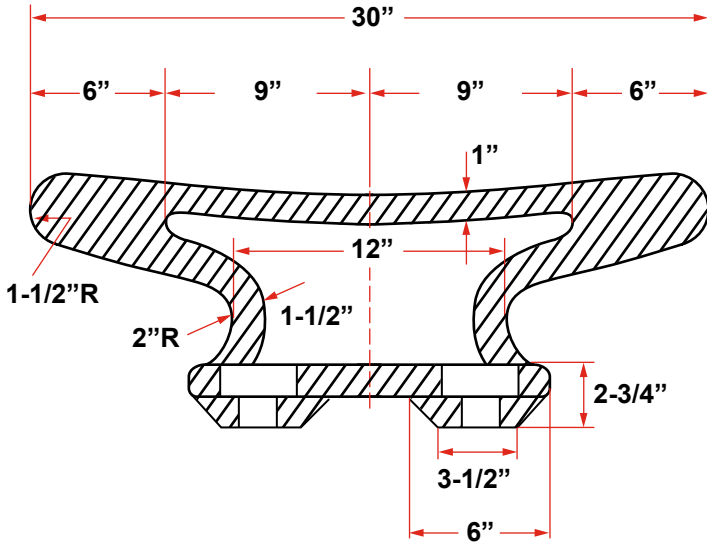

1-1/2" Ø CORE FOR
1-1/4" Ø BOLT

10 TON CLEAT AMC-10A

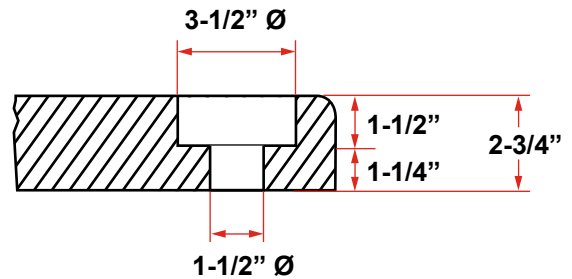
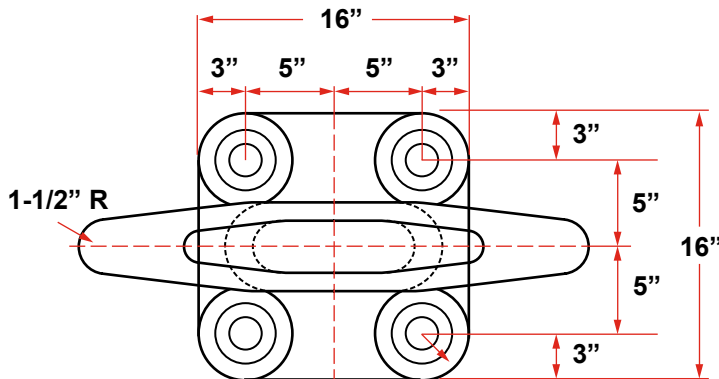
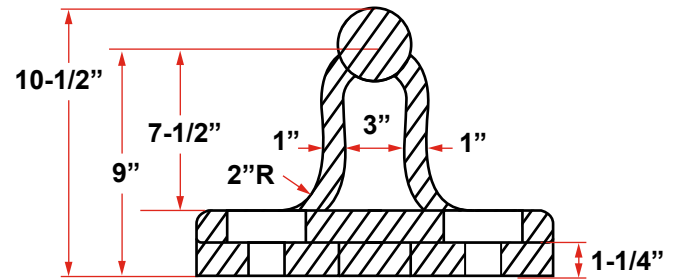
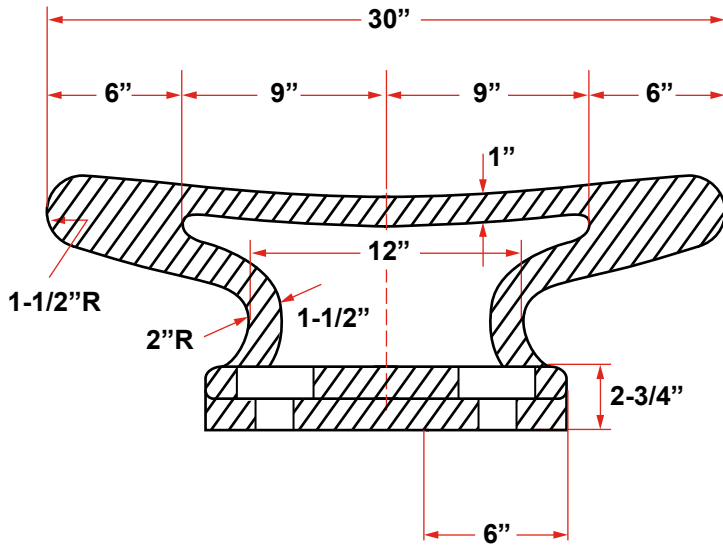

1-1/2" Ø CORE FOR
1-1/4" Ø BOLT

10 TON CLEAT AMC-10

AMCH 6-BOLT CLEATS

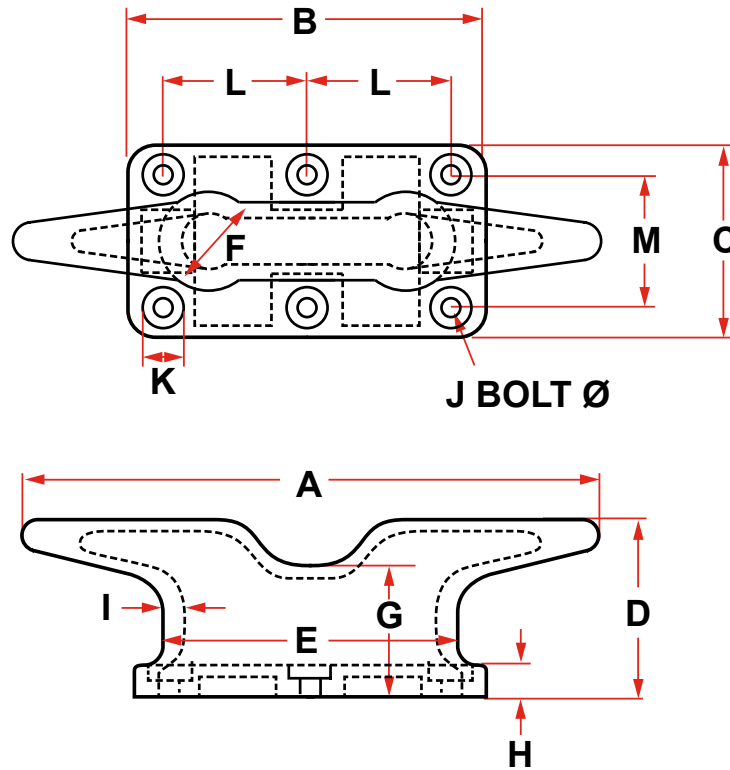

DIMENSIONS (INCHES)													
	A	B	C	D	E	F	G	H	I	J	K	L	M
AMCH-16	16	10-1/2	7-1/2	5	8	2-3/4	3-3/4	1-1/2	7/8	3/4	1-3/4	3-3/4	4-1/2
AMCH-24	24	15-1/2	9-1/2	7-1/4	12	4	5-1/4	1-3/4	1-1/8	7/8	2	6	6
AMCH-30	30	19	11-1/4	8-7/8	15	5	6-3/8	2	1-1/4	1	2-1/4	7-1/2	7-1/4

AMCH 8-BOLT CLEATS

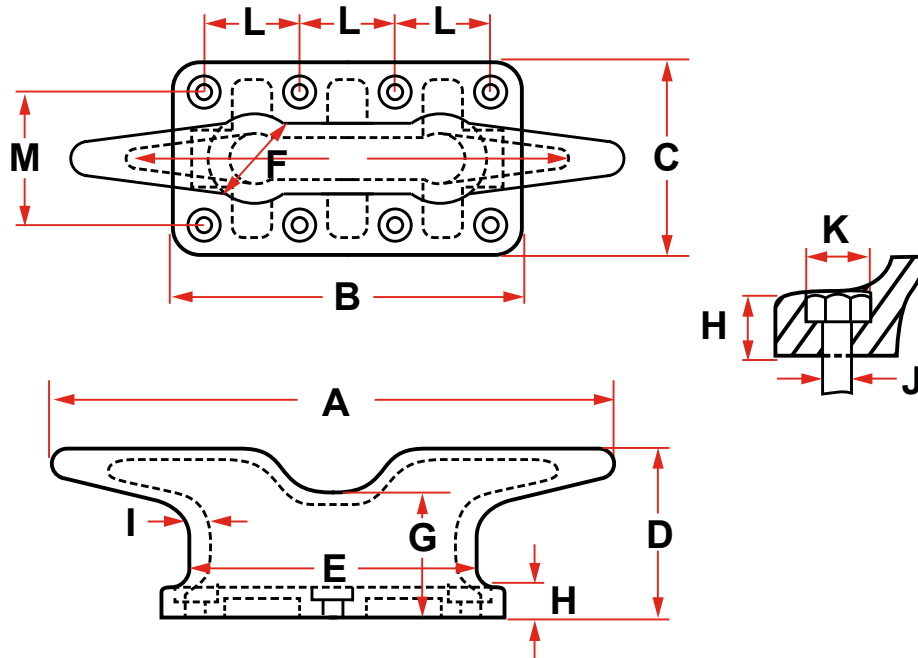

DIMENSIONS (INCHES)													
	A	B	C	D	E	F	G	H	I	J	K	L	M
AMCH-36	36	22-1/2	12-1/4	10-1/2	18	6	7-1/2	2	1-3/8	1	2-1/4	6-1/4	8-1/4
AMCH-42	42	26	14-1/4	13	21	7	8-5/8	2	1-1/2	1	2-1/4	7-1/2	9-1/4
AMCH-48	48	29-3/4	15-1/8	13-3/4	24	8	9-3/4	2-1/4	1-5/8	1-1/8	2-5/8	8-1/2	10-5/8
AMCH-54	54	33-1/2	16-3/4	16	27	8	12	2-1/2	1-5/8	1-3/8	2-3/4	9-1/2	11-3/4

AMC-200 SERIES 2-BOLT CLEATS

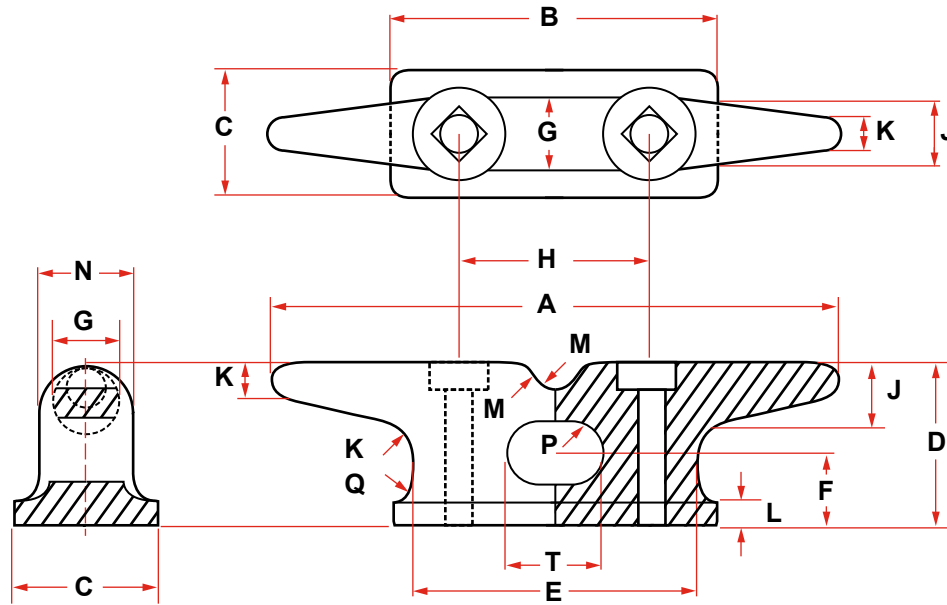

DIMENSIONS (INCHES)

	A	B	C	D	E	F	G	H	J	K	L	M	N	P	Q	R	T	U
AMC-216	16	9-1/2	3-5/8	4-1/8	8	1-1/2	2	5-1/4	1-3/4	7/8	5/8	3/4	2-3/4	1/2	7/16	1-3/8	2-1/2	3/4
AMC-220	20	11	4-1/2	5-3/8	10	2	2-1/2	6-5/8	2-1/4	1-1/8	3/4	7/8	3-3/8	3/4	9/16	1-9/16	3-1/4	7/8
AMC-224	24	13-1/2	5-3/8	6-3/8	12	2-1/2	3	8	2-3/4	1-3/8	7/8	1	4	1	11/16	1-3/4	4	1
AMC-227	27	15	6	7-3/8	13-1/2	3	3-3/8	9	3-1/8	1-9/16	1	1-1/8	4-1/2	1-1/4	13/16	1-15/16	4-1/2	1-1/8
AMC-230	30	17	6-3/4	8	15	3-1/2	3-3/4	10	3-1/2	1-3/4	1-1/8	1-1/4	5	1-1/2	7/8	2-1/8	5	1-1/4
AMC-233	33	19	7-3/8	9	16-1/2	4	4-7/8	11	3-3/4	1-7/8	1-1/4	1-3/8	5-1/2	1-3/4	15/16	2-3/8	5-1/2	1-3/8
AMC-236	36	21	8	9-7/8	18	4-1/2	4-1/2	12	4	2	1-3/8	1-1/2	6	2	1	2-5/8	6	1-1/2
AMC-242	42	24	9-3/8	11-5/8	21	5	5-1/4	14	4-3/4	2-3/8	1-1/2	1-3/4	7	2-1/4	1-3/16	2-7/8	7	1-3/4
AMC-248	48	27	10-3/4	13-1/8	24	5-1/2	6	16	5-1/2	2-3/4	1-5/8	2	8	2-1/2	1-3/8	3-3/8	8	2
AMC-254	54	30	12	14-3/4	27	6	6-3/4	18	6	3	1-3/4	2-1/4	9	2-3/4	1-1/2	3-3/4	9	2-1/4

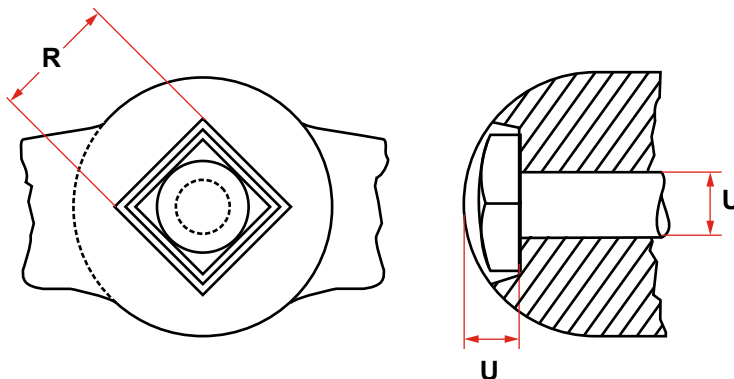

CLEAT AMC-216-254

AMC-50 CLEAT

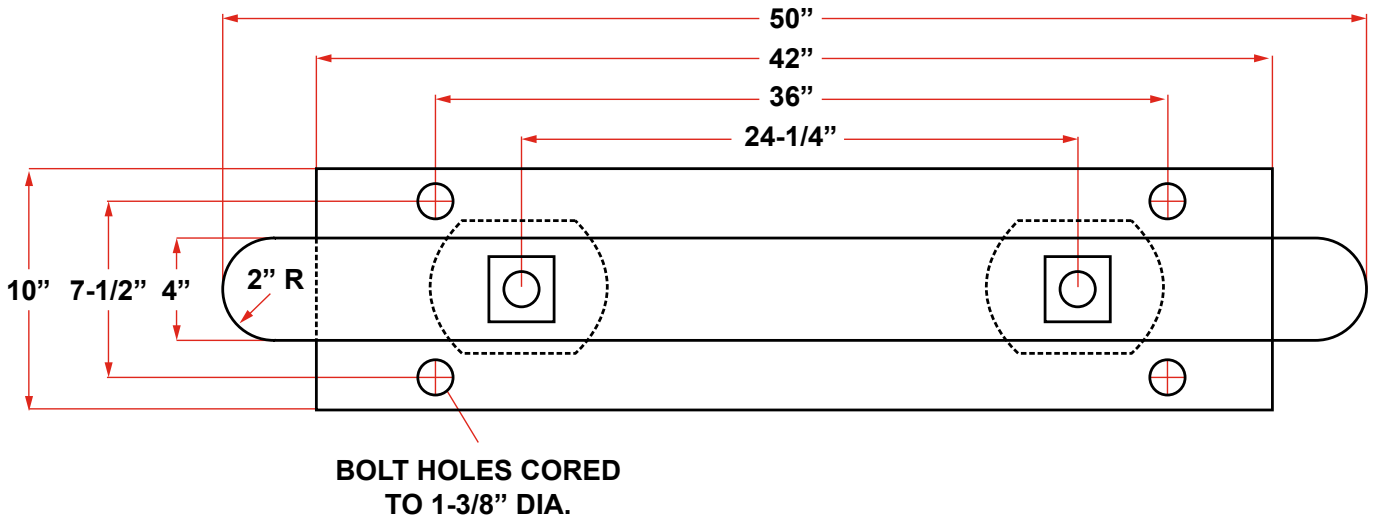
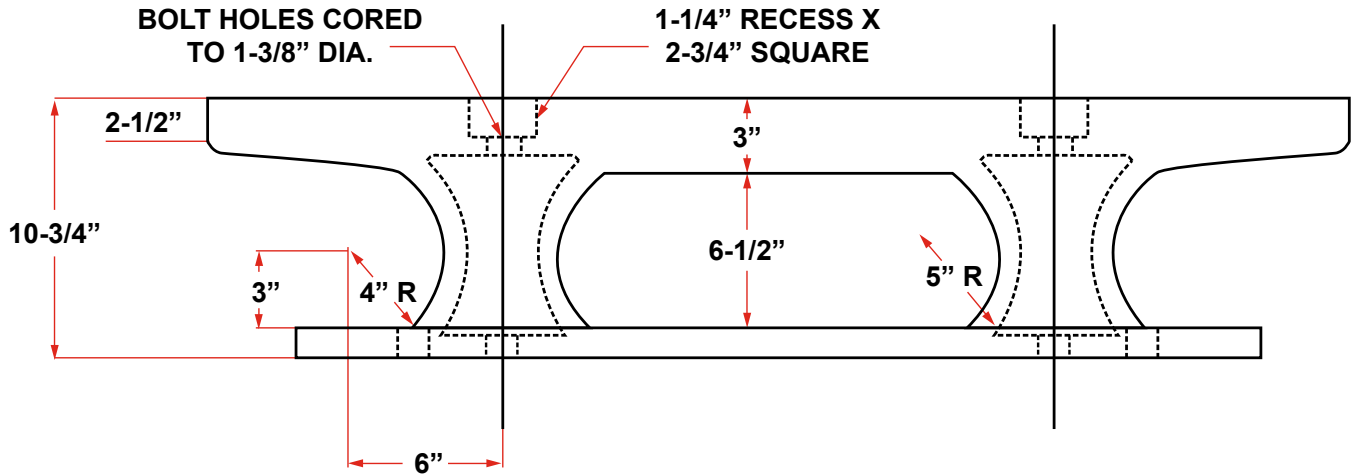

12" STD. NAVY CLEAT

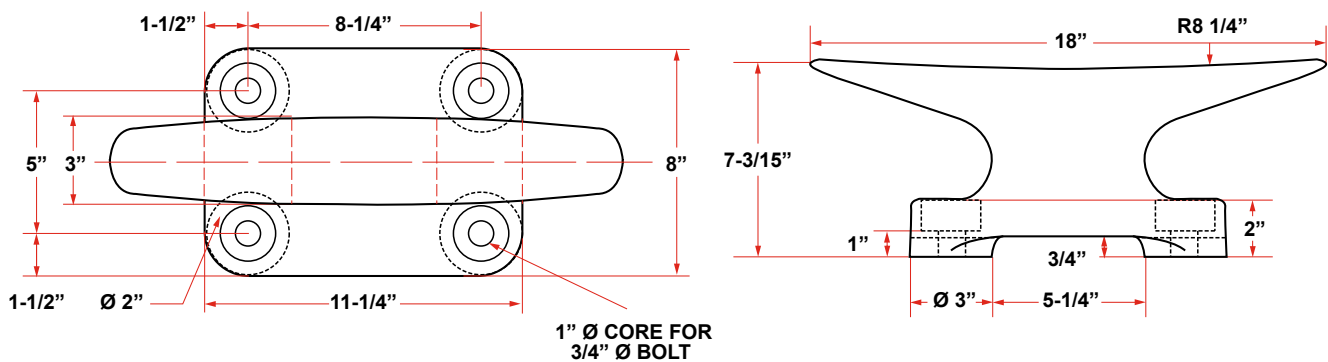
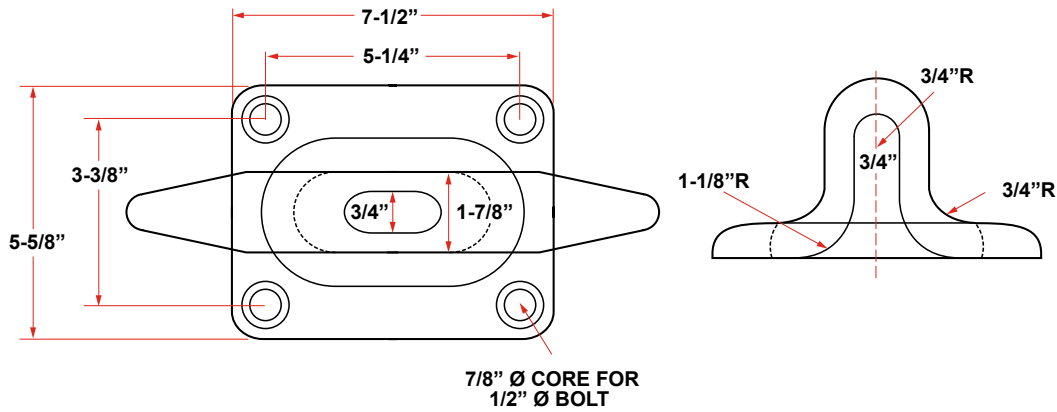
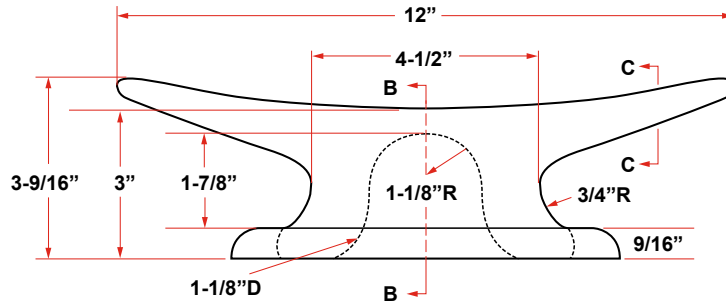

AMC-18 CLEAT

DOORS/HATCHES



WATERTIGHT DOORS

HATCHES

SCUTTLES

PORT LIGHTS

LET US KNOW YOUR REQUIREMENTS

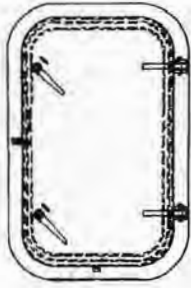

#100 2-DOG
FUMELIGHT DOOR

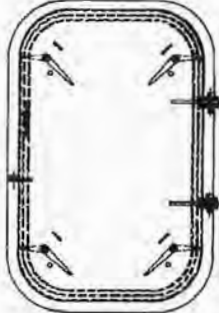

#101 4-DOG
WEAHERTIGHT DOOR

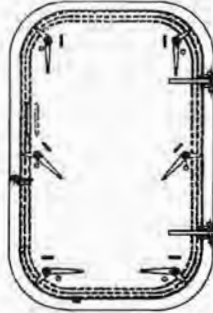

#102 6-DOG
WATERTIGHT DOOR

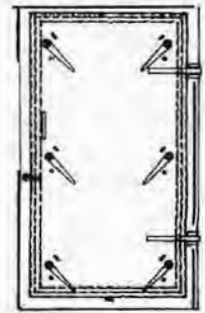

#103 6-DOG
SQUARE CORNER DOOR

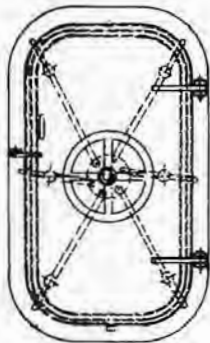

#104 6-DOG
QUICK ACTING DOOR

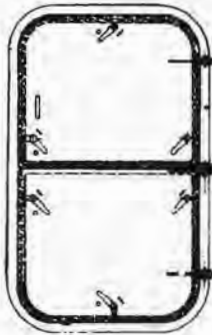

#105 6-DOG
DUTCH DOOR

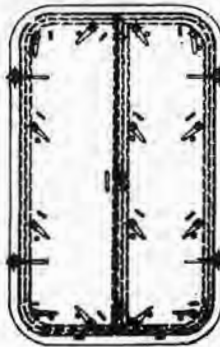

#106
DOUBLE DOOR

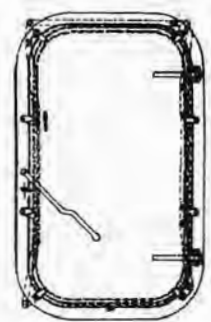

#109
QUICK ACTING LEVER
OPERATED DOOR

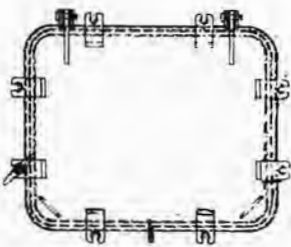

#200
DROP BOLT HATCH

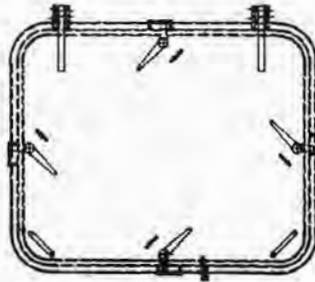

#201
WATERTIGHT HATCH

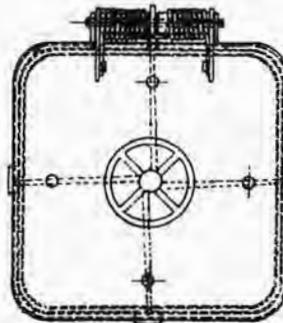

#202
QUICK ACTING SPRING
BALANCED HATCH

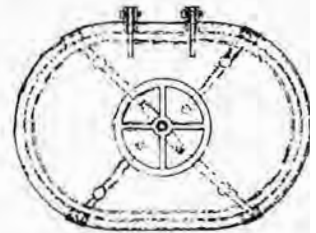

#203
QUICK ACTING OVAL
HATCH

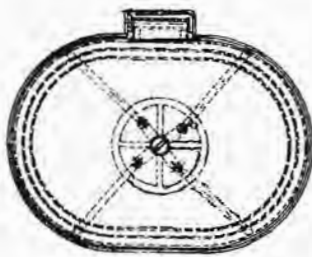

#204
QUICK ACTING FLUSH
OVAL HATCH

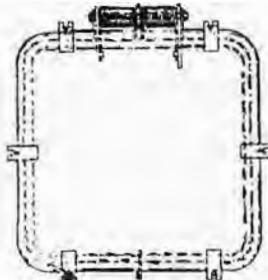

#207
SPRING BALANCED
DROP BOLT HATCH

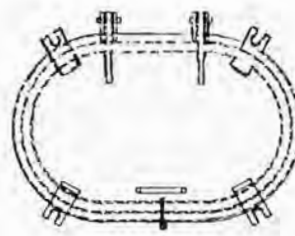

#208
OVAL DROP BOLT
HATCH

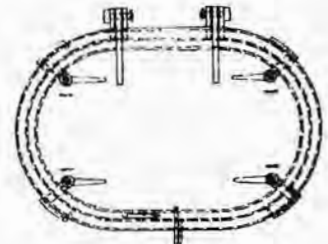

#209
OVAL DOGGED HATCH

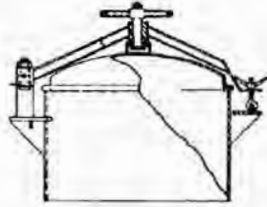

#210
OIL CARGO HATCH

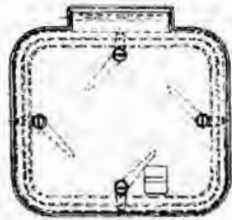

#211
FLUSH HATCH

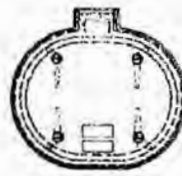

#212
FLUSH OVAL HATCH

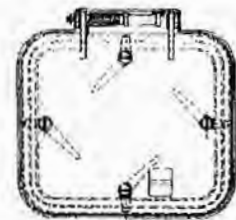

#213
SPRING BALANCED
FLUSH HATCH

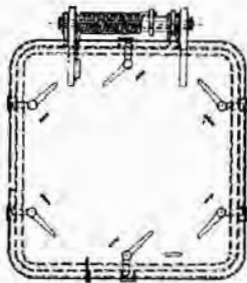

#214
SPRING BALANCED
DOGGED HATCH

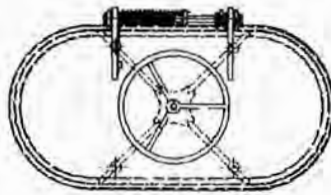

#215
SPRING BALANCED
OVAL QUICK ACTING
HATCH

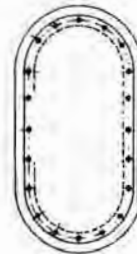

#300
BOLTED PLATE
MANHOLE

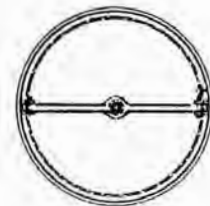

#301
SINGLE BOLT
MANHOLE



#400
SPRING BALANCED
QUICK ACTING
SCUTTLE



#401
QUICK ACTING
FLUSH SCUTTLE

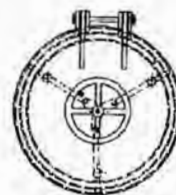

#402
QUICK ACTING RAISED
SCUTTLE

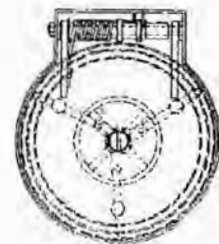

#403
QUICK ACTING
SPRING BALANCED
FLUSH SCUTTLE

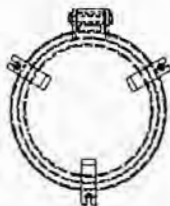

#403
DROP BOLT
RAISED
SCUTTLE



#405
DOGGED
RAISED
SCUTTLE



#406
FLUSH TOP
RAISED
SCUTTLE



#407
DOGGED
FLUSH
SCUTTLE



#500 FIXED
LIGHT

WEATHERTIGHT DOOR WITH 2 DOGS DRAWING NO. 100

SCHEDULE OF MATERIAL

PC. NO.	MATERIAL
1	Mild Steel
2	Mild Steel
3	Frg. Stl.
4	Mild Steel
5	Mild Steel
6	Brass
7	Teflon
8	Stainless
9	Mild Steel
10	Neoprene
11	Teflon
12	Delrin
13	Plated Steel
14	Frg. Stl.
15	Mild Steel
16	Frg. Stl.
17	Mild Steel
18	Mild Steel
19	Mild Steel
20	Mild Steel
21	Plated Steel
22	Mild Steel
23	Stainless
24	Mild Steel

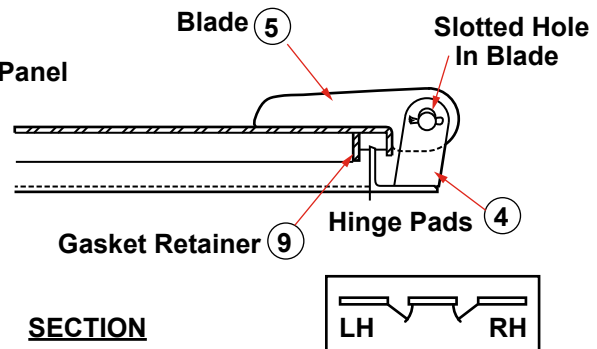
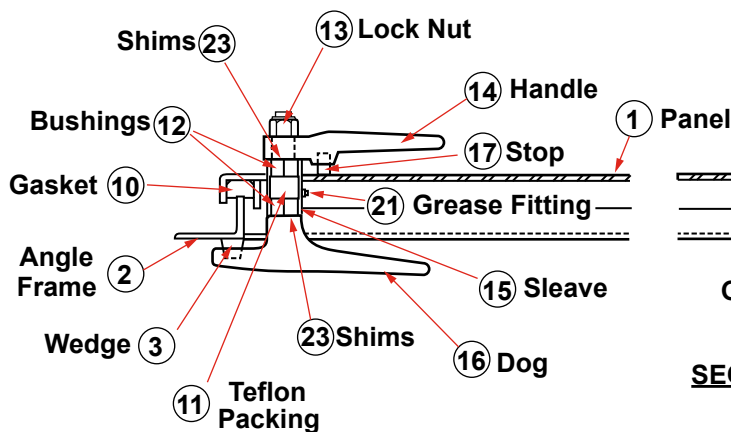
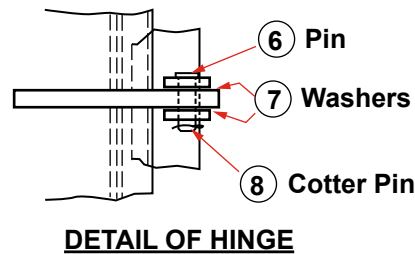
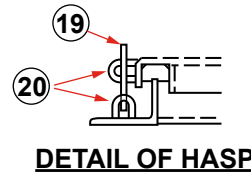
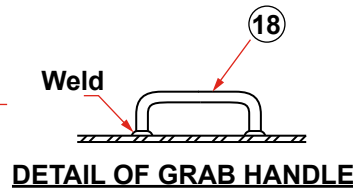
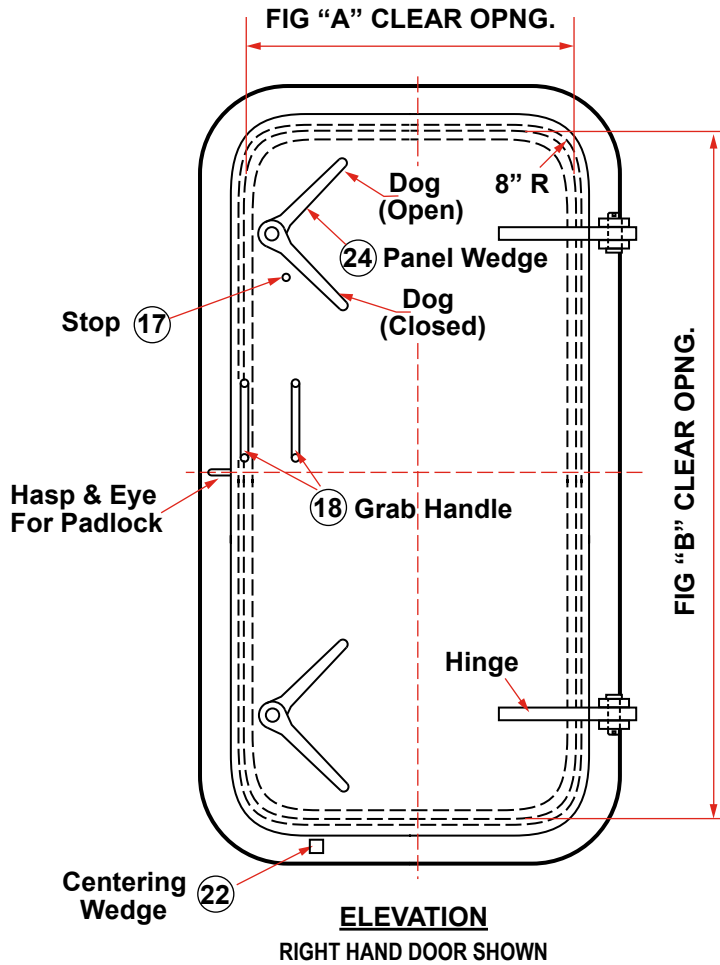

WATERTIGHT DOOR WITH 4 DOGS DRAWING NO. 101

SCHEDULE OF MATERIAL

PC. NO.	MATERIAL
1	Mild Steel
2	Mild Steel
3	Frg. Stl.
4	Mild Steel
5	Mild Steel
6	Brass
7	Teflon
8	Stainless
9	Mild Steel
10	Neoprene
11	Teflon
12	Delrin
13	Plated Steel
14	Frg. Stl.
15	Mild Steel
16	Frg. Stl.
17	Mild Steel
18	Mild Steel
19	Mild Steel
20	Mild Steel
21	Plated Steel
22	Mild Steel
23	Stainless
24	Mild Steel
25	Mild Steel

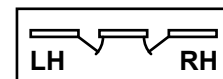
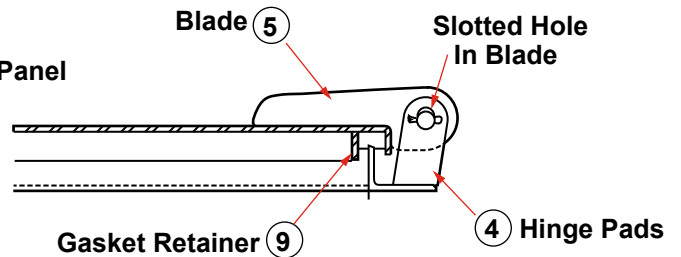
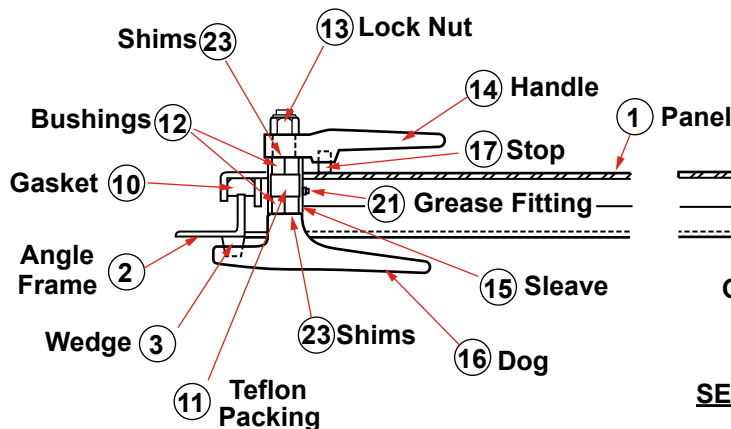
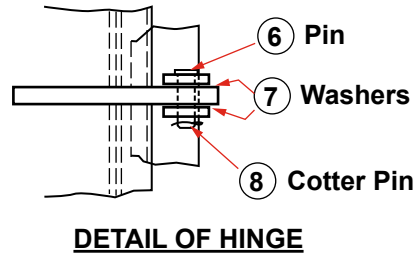
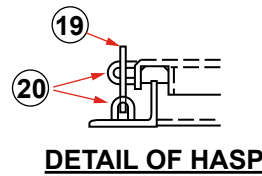
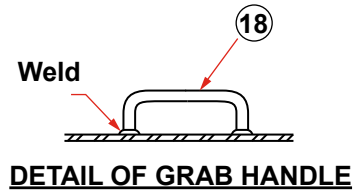
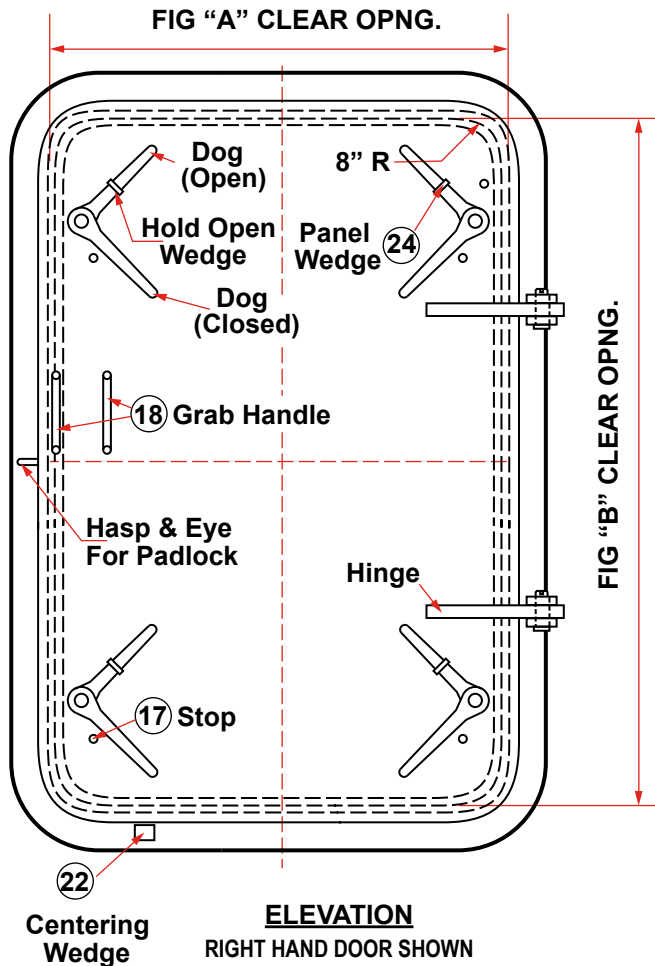

WATERTIGHT DOOR WITH 6 DOGS DRAWING NO. 102

SCHEDULE OF MATERIAL

PC. NO.	MATERIAL
1	Mild Steel
2	Mild Steel
3	Frg. Stl.
4	Mild Steel
5	Mild Steel
6	Brass
7	Teflon
8	Stainless
9	Mild Steel
10	Neoprene
11	Teflon
12	Delrin
13	Plated Steel
14	Frg. Stl.
15	Mild Steel
16	Bronze
17	Mild Steel
18	Mild Steel
19	Mild Steel
20	Mild Steel
21	Plated Steel
22	Mild Steel
23	Stainless
24	Mild Steel

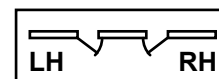
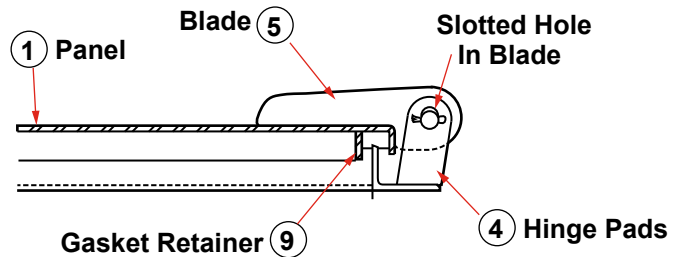
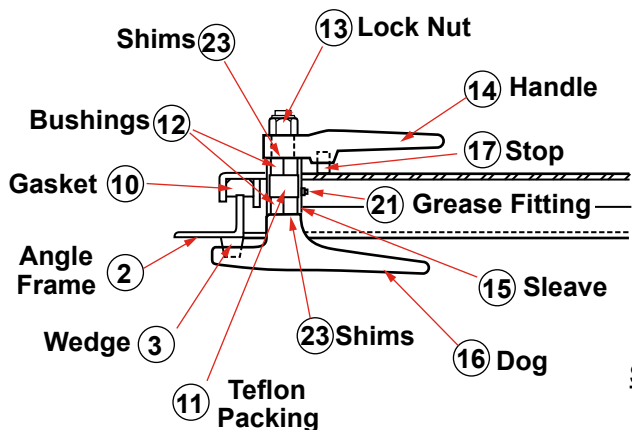
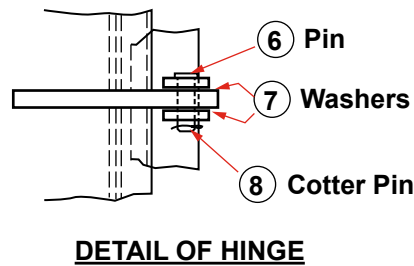
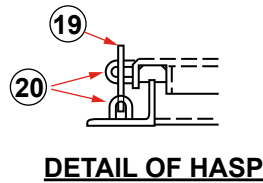
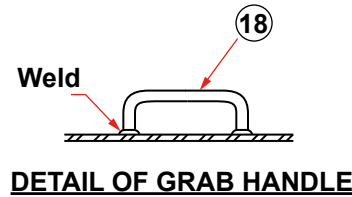
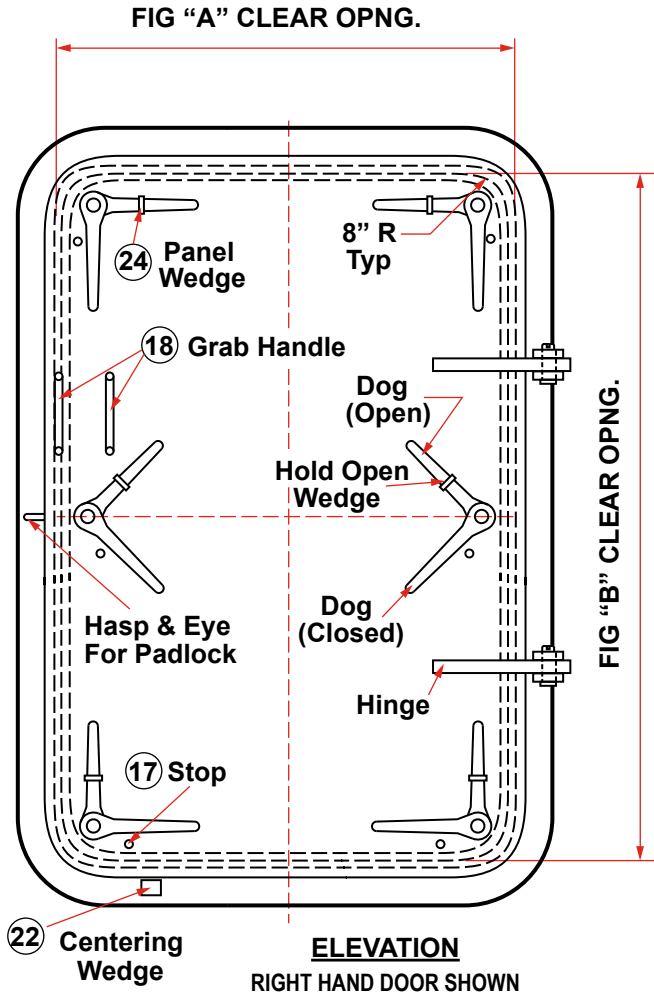

WATERTIGHT DOOR WITH 6 DOGS DRAWING NO. 103

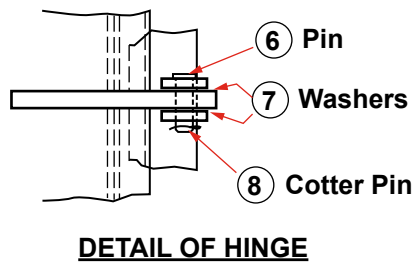
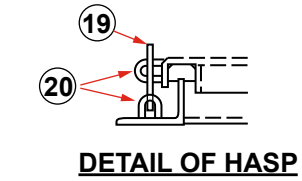
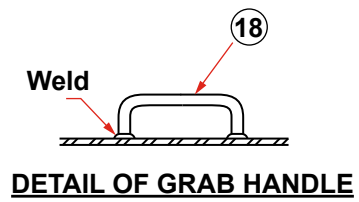
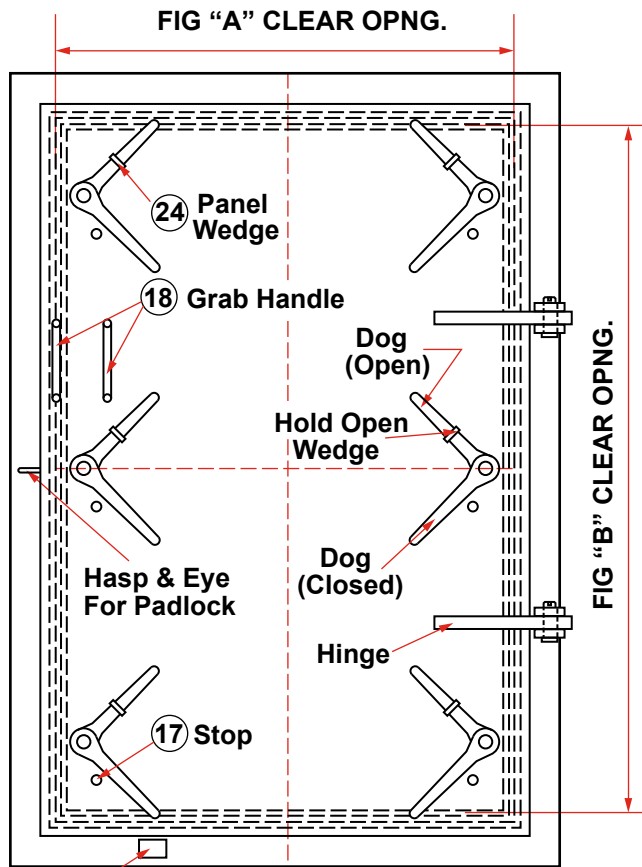

SCHEDULE OF MATERIAL

PC. NO.	MATERIAL
1	Mild Steel
2	Mild Steel
3	Frg. Stl.
4	Mild Steel
5	Mild Steel
6	Brass
7	Teflon
8	Stainless
9	Mild Steel
10	Neoprene
11	Teflon
12	Delrin
13	Plated Steel
14	Frg. Stl.
15	Mild Steel
16	Frg. Stl.
17	Mild Steel
18	Mild Steel
19	Mild Steel
20	Mild Steel
21	Plated Steel
22	Mild Steel
23	Stainless
24	Mild Steel

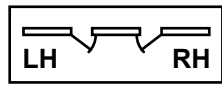
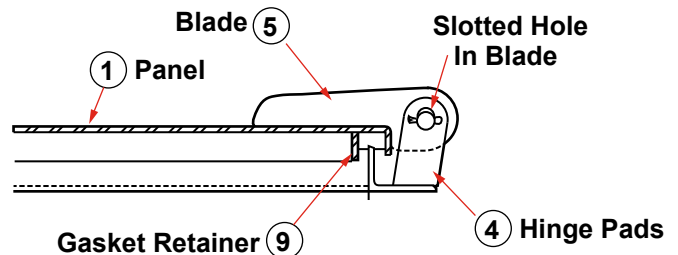
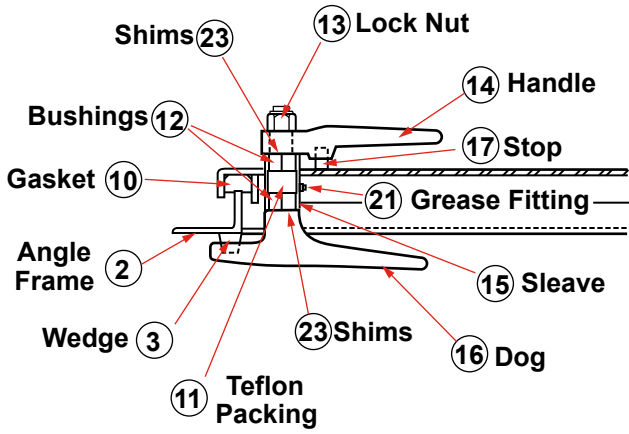

QUICK ACTING WATERTIGHT DOOR DRAWING NO. 104

SCHEDULE OF MATERIAL

PC. NO.	MATERIAL
1	Mild Steel
2	Mild Steel
3	Brass
4	Teflon
5	Stainless
6	Plated Steel
7	Neoprene
8	Cold Finish
9	Cold Finish
10	Mild Steel
11	Mild Steel
12	Mild Steel
13	Teflon
14	Mild Steel
15	Mild Steel
16	Mild Steel
17	Stainless
18	Mild Steel
19	Plated Steel
20	Mild Steel
21	Delrin
22	Stainless
23	Plated Steel
24	Mild Steel
25	Mild Steel
26	Brass
27	Spring Steel
28	Brass
29	Mild Steel
30	Cold Finish
31	Brass
32	Plated Steel

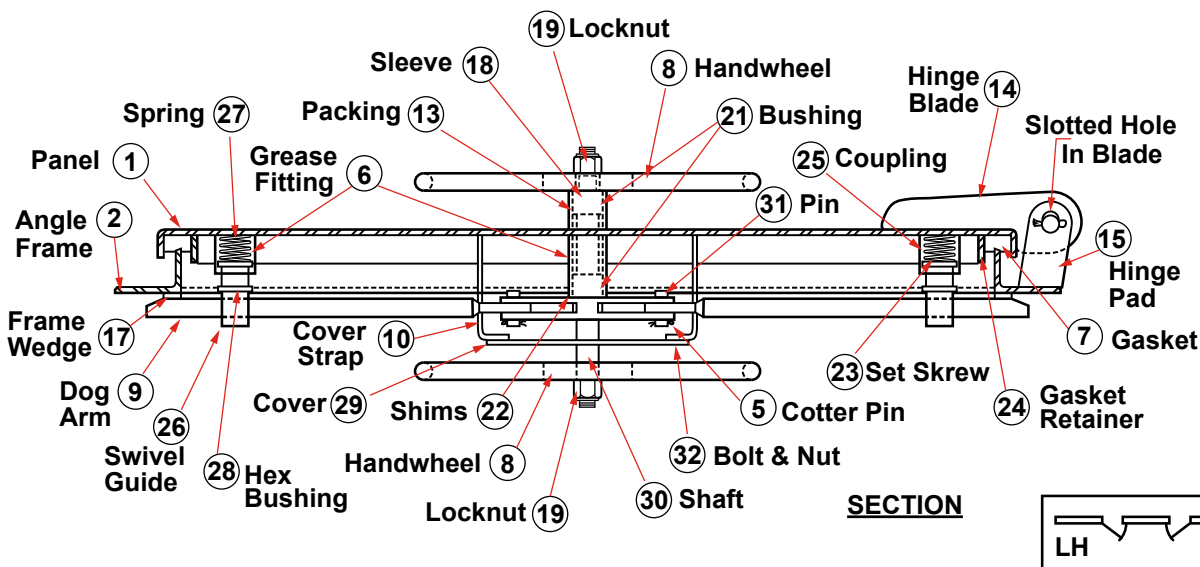
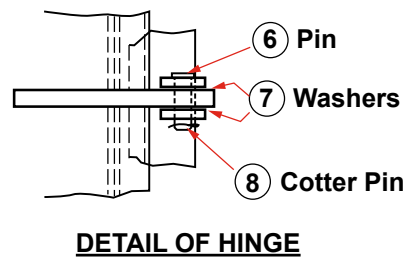
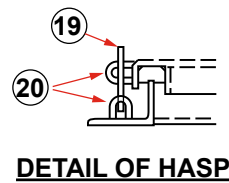
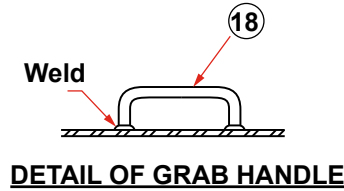
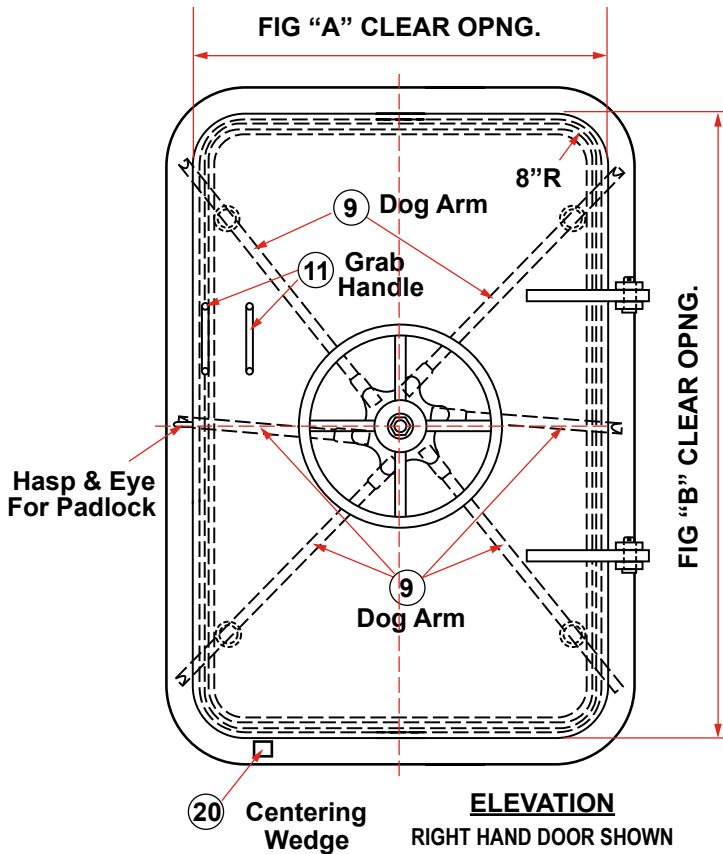

QUICK ACTING LEVER TYPE DOOR DRAWING NO. 109

SCHEDULE OF MATERIAL

PC. NO.	MATERIAL
1	Mild Steel
2	Mild Steel
3	Neoprene
4	Mild Steel
5	Mild Steel
6	Brass
7	Stainless
8	Stainless
9	Forged Stl
10	Forged Stl
11	Teflon
12	Mild Steel
13	Plated Steel
14	Cold Finish
15	Mild Steel
16	Plated Steel
17	Olite Bronze
18	Mild Steel
19	Mild Steel
20	Mild Steel
21	Plated Steel
22	Mild Steel
23	Olite Bronze
24	Cold Finish
25	Frg. Stl.
26	Bronze
27	Mild Steel
28	Brass
29	Mild Steel
30	Stainless
31	Mild Steel
32	Mild Steel

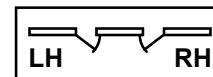
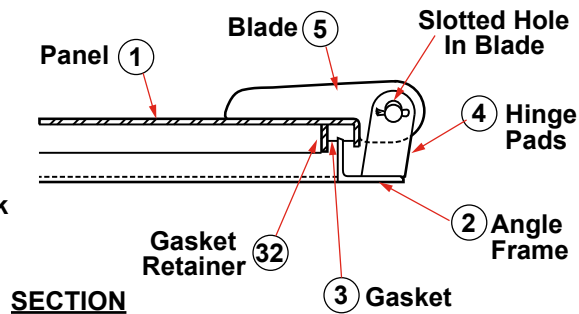
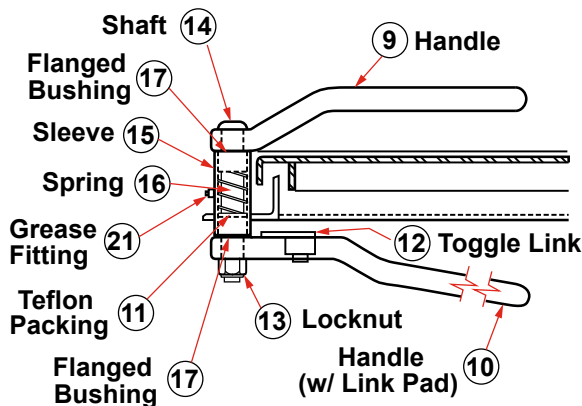
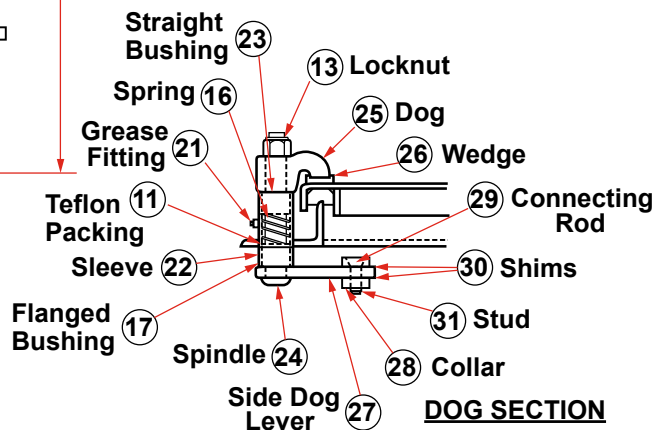
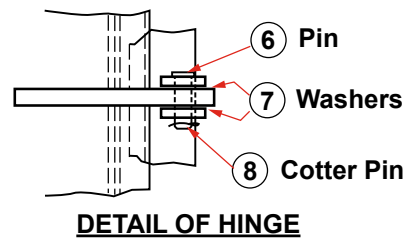
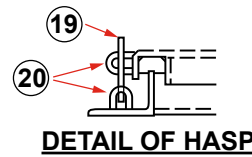
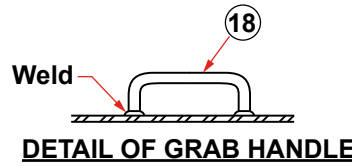
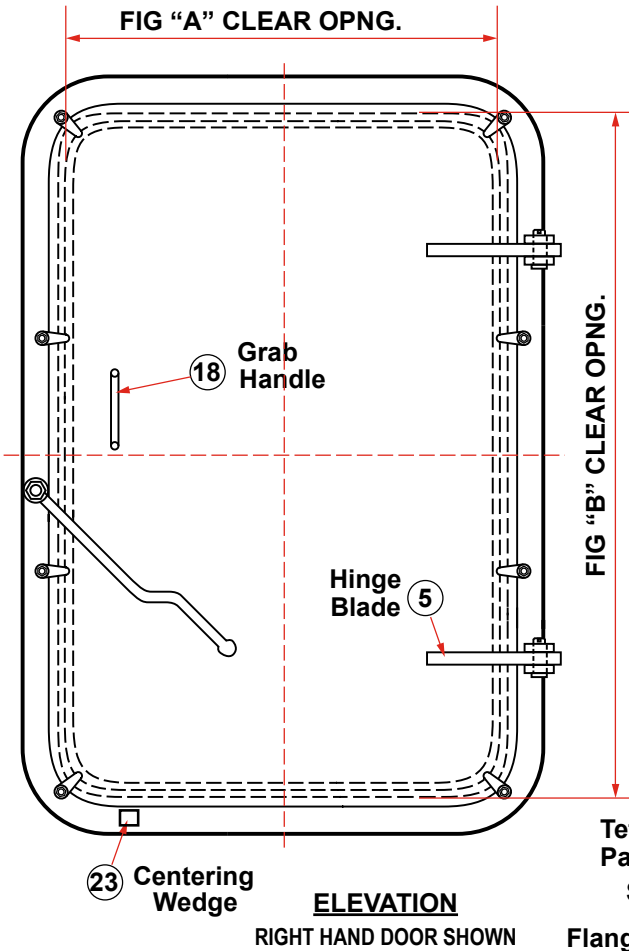

DRAWING NO. 201

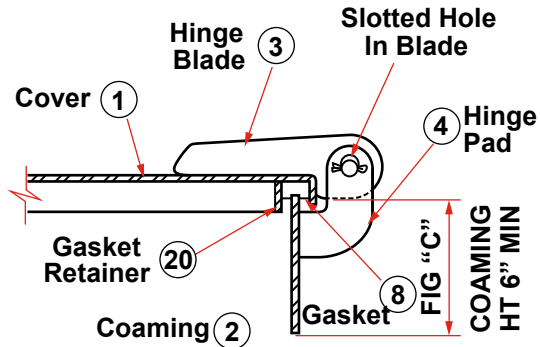
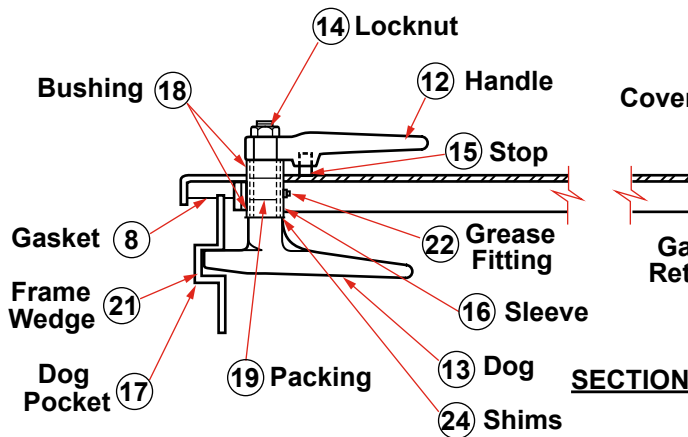
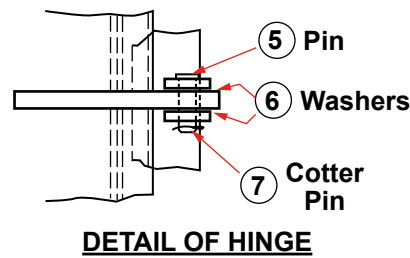
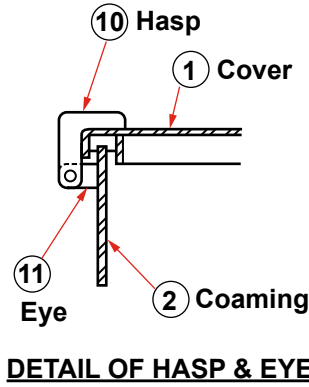
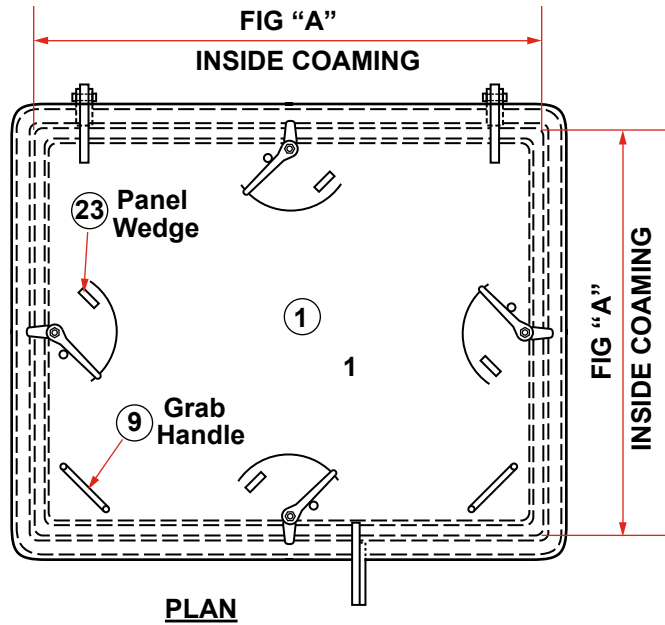

SCHEDULE OF MATERIAL

PC. NO.	MATERIAL
1	Mild Steel
2	Mild Steel
3	Mild Steel
4	Mild Steel
5	Brass
6	Stainless
7	Stainless
8	Neoprene
9	Steel
10	Mild Steel
11	Mild Steel
12	Frg. Stl.
13	Frg. Stl.
14	Plated Steel
15	Steel
16	Steel
17	Steel
18	Delrin
19	Teflon
20	Mild Steel
21	Frg. Stl.
22	Plated Steel
23	Mild Steel
24	Stainless

SPRING BALANCE QUICK ACTING WATERTIGHT HATCH DRAWING NO. 202

SCHEDULE OF MATERIAL

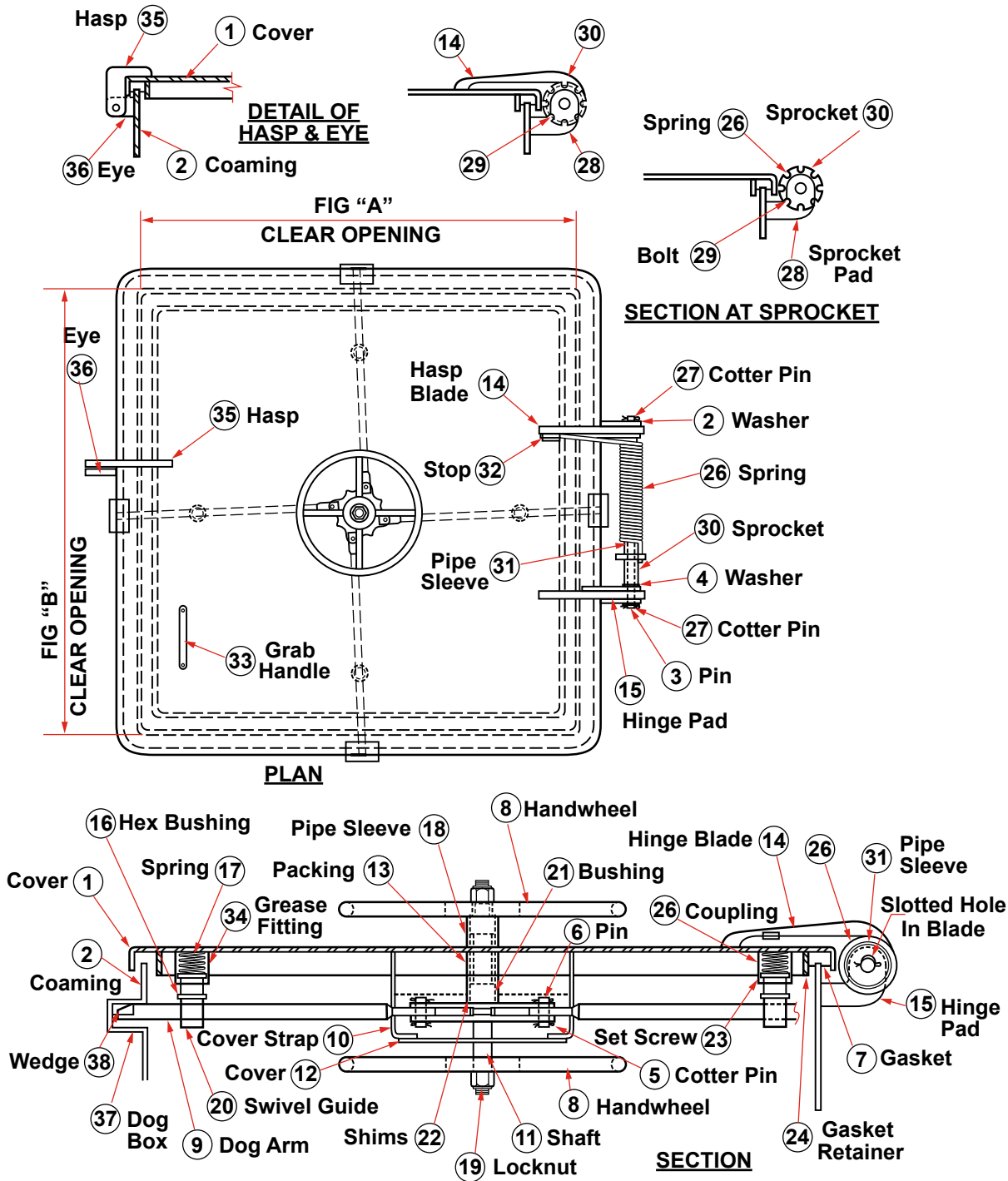

PC. NO.	MATERIAL
1	Mild Steel
2	Mild Steel
3	Cold Finish
4	Stainless
5	Stainless
6	Brass
7	Neoprene
8	Mild Steel
9	Mild Steel
10	Mild Steel
11	Cold Finish
12	Mild Steel
13	Teflon
14	Mild Steel
15	Mild Steel
16	Brass
17	Plated Steel
18	Mild Steel
19	Plated Steel
20	Brass
21	Derlin
22	Stainless
23	Plated Steel
24	Mild Steel
25	Mild Steel
26	Stainless
27	Stainless
28	Mild Steel
29	Brass
30	Mild Steel
31	Mild Steel
32	Mild Steel
33	Mild Steel
34	Plated Steel
35	Mild Steel
36	Mild Steel
37	Mild Steel
38	Mild Steel
39	Stainless
40	Mild Steel
41	Mild Steel

**QUICK ACTING OVAL HATCH
DRAWING NO. 203**

**SCHEDULE OF
MATERIAL**

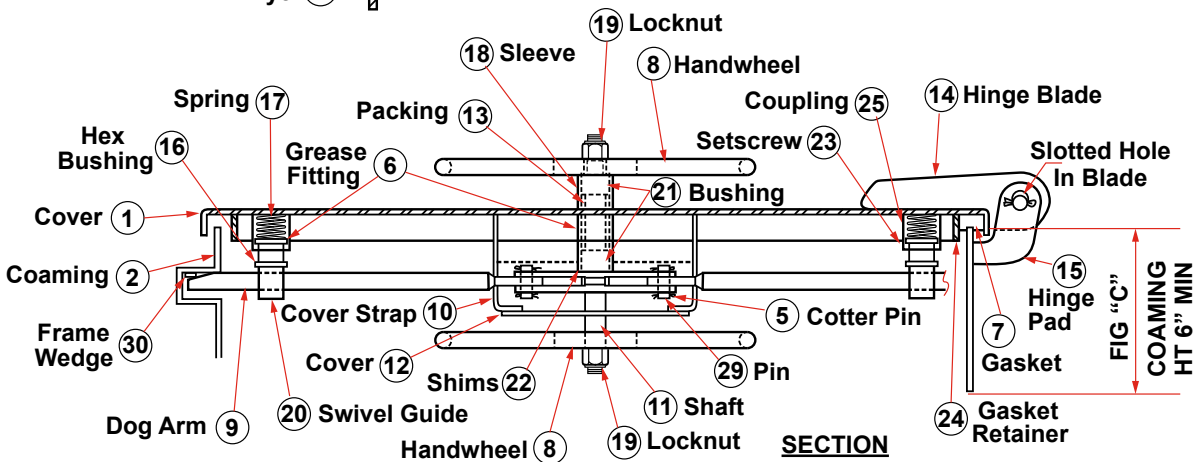
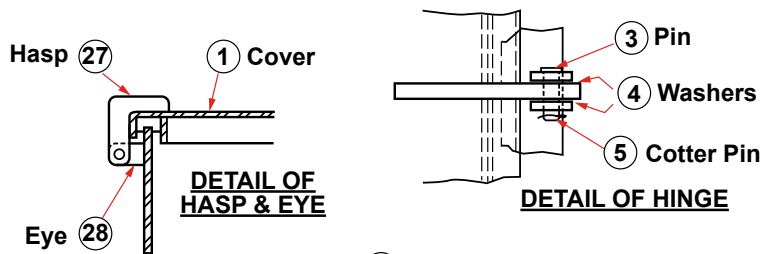
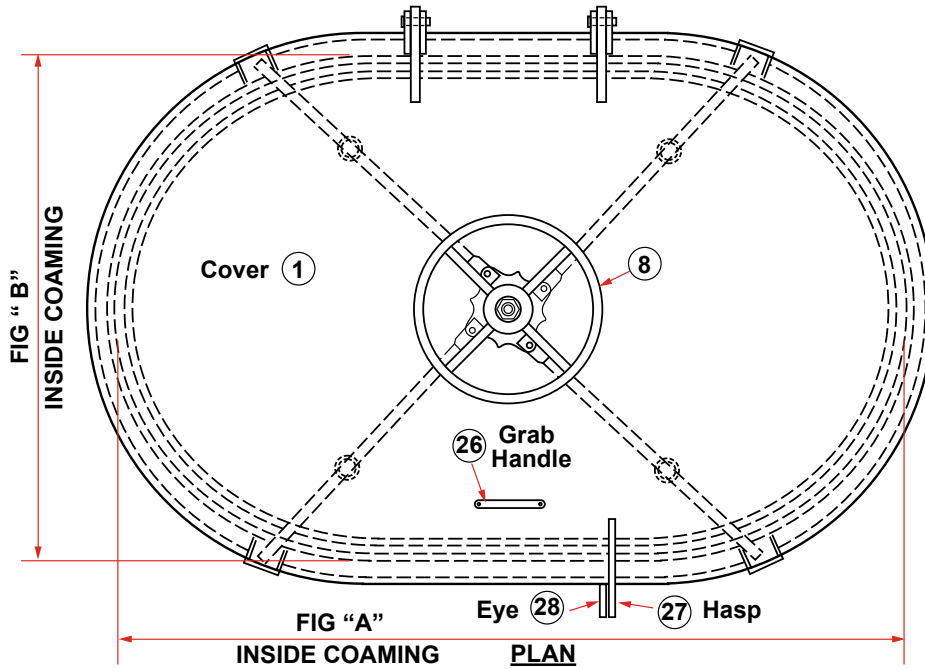

PC. NO.	MATERIAL
1	Mild Steel
2	Mild Steel
3	Brass
4	Brass
5	Brass
6	Brass
7	Neoprene
8	Mild Steel
9	Mild Steel
10	Mild Steel
11	Cold Finish
12	Mild Steel
13	Graphite
14	Mild Steel
15	Mild Steel
16	Mild Steel
17	Spring Steel
18	Mild Steel
19	Mild Steel
20	Brass
21	Delrin
22	Brass
23	Steel
24	Mild Steel
25	Mild Steel
26	Mild Steel
27	Mild Steel
28	Mild Steel
29	Brass
30	Mild Steel

QUICK ACTING FLUSH OVAL HATCH DRAWING NO. 204

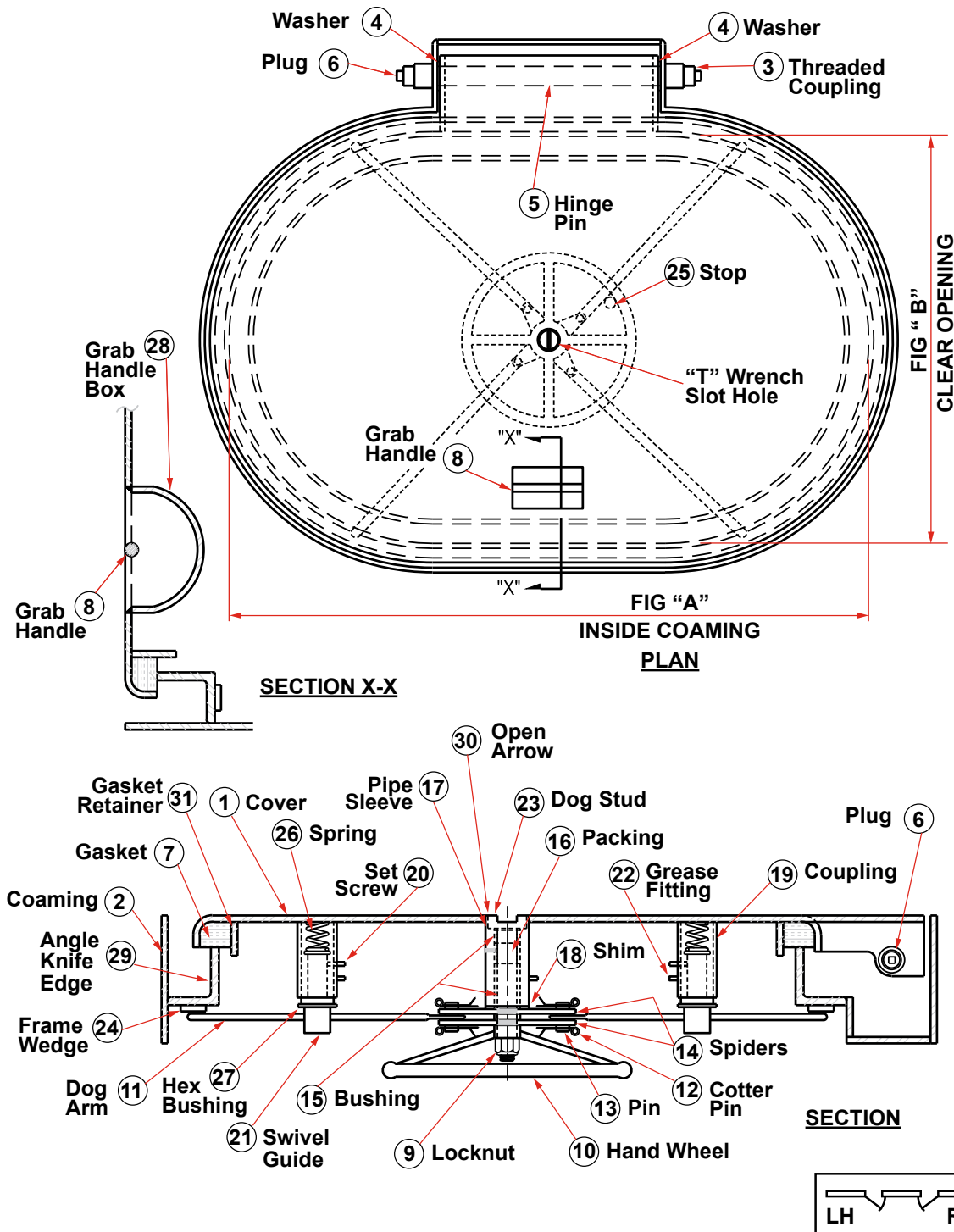

SCHEDULE OF MATERIAL

PC. NO.	MATERIAL
1	Mild Steel
2	Mild Steel
3	Mild Steel
4	Stainless
5	Cold Finish
6	Steel
7	Neoprene
8	Mild Steel
9	Plated Steel
10	Mild Steel
11	Mild Steel
12	Stainless
13	Brass
14	Mild Steel
15	Delrin
16	Teflon
17	Mild Steel
18	Brass
19	Mild Steel
20	Plated Steel
21	Brass
22	Plated Steel
23	Brass
24	Mild Steel
25	Mild Steel
26	Plated Steel
27	Brass
28	Steel
29	Mild Steel
30	Stainless
31	Mild Steel

OIL CARGO HATCH DRAWING NO. 210

SCHEDULE OF MATERIAL

PC. NO.	MATERIAL
1	Mild Steel
2	Mild Steel
3	Mild Steel
4	Mild Steel
5	Mild Steel
6	Plated Steel
7	Plated Steel
8	Mild Steel
9	Stainless
10	Brass
11	Plated Steel
12	Stainless
13	Mild Steel
14	Mild Steel
15	Mild Steel
16	Manganese Bronze
17	Manganese Bronze
18	Brass
19	Mild Steel
20	Neoprene
21	Mild Steel
22	Stainless
23	Steel
24	Plated Steel
25	Steel
26	Steel
27	Stainless
28	Stainless
29	Plated Steel
30	Brass
31	Steel

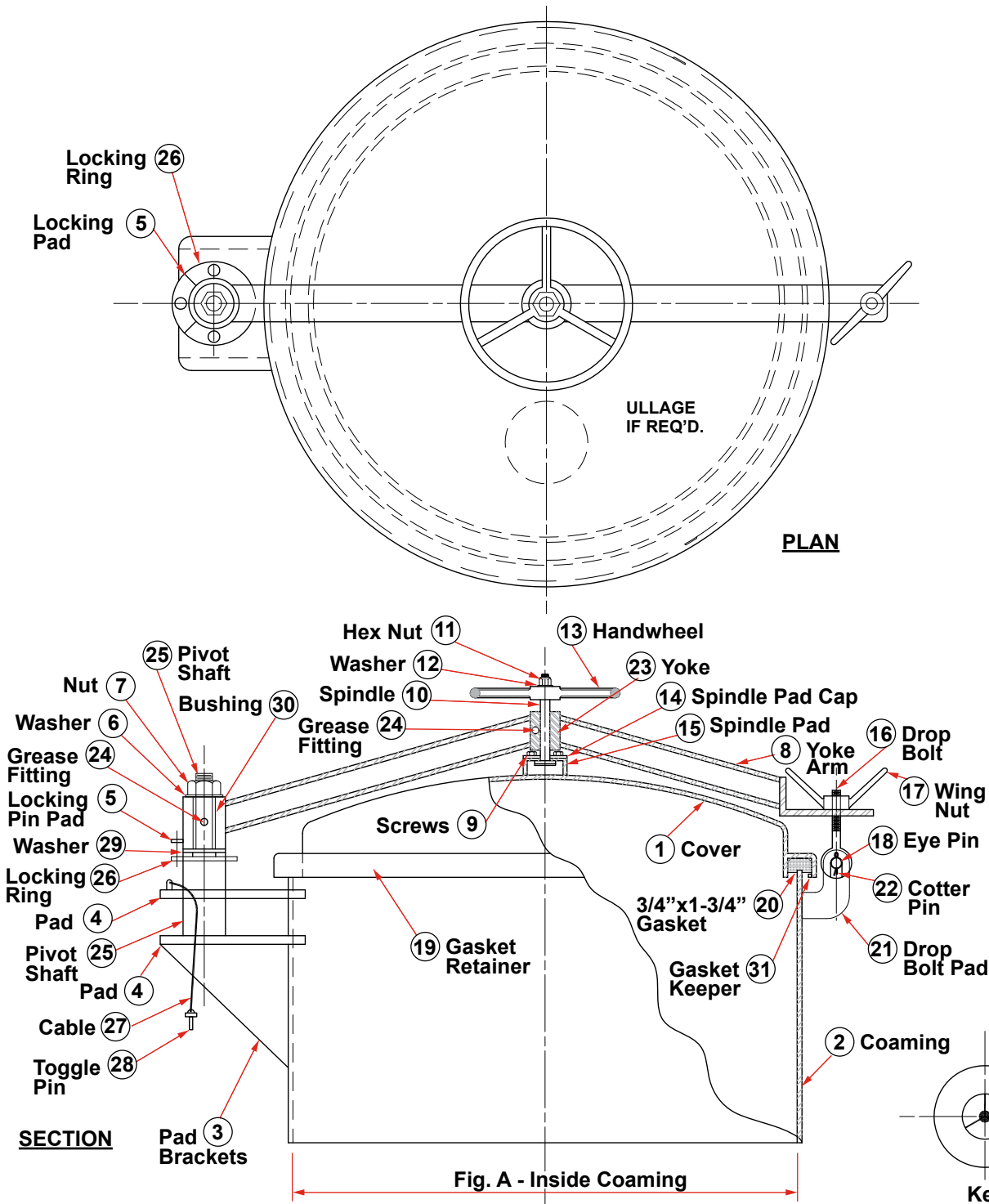

FLUSH WATERTIGHT T-HANDLE HATCH

NOTE 1: INCLUDES ALL PIECES EXCEPT PC. NO. 2 - DECK RING

The specifications and details described by drawings or text in this literature are subject to change without notice

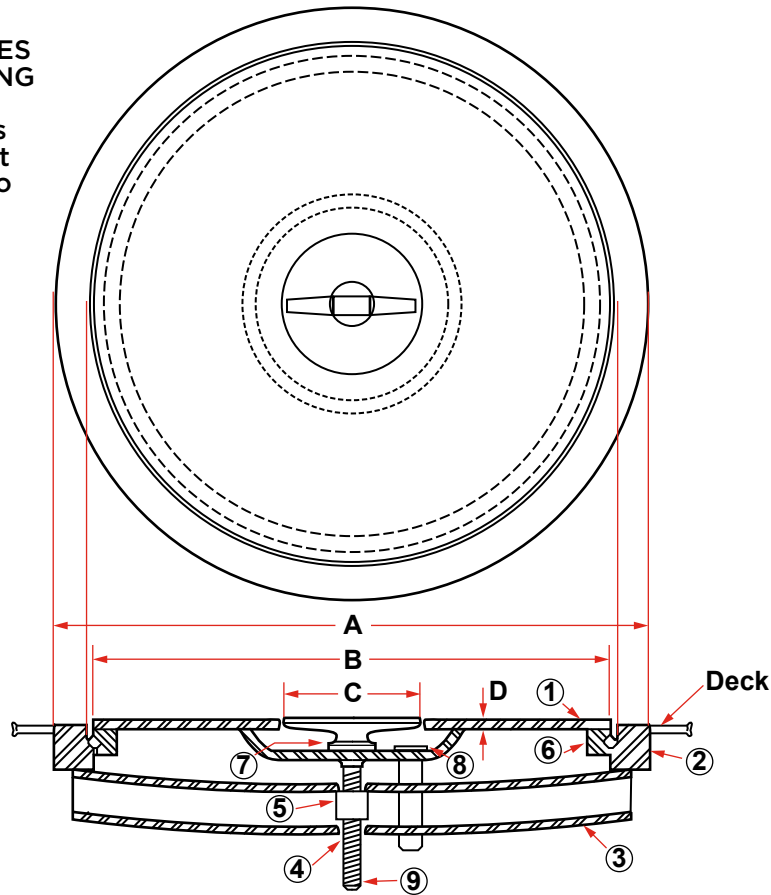

PIECE NO.	DESCRIPTION	PART NUMBER		MATERIAL
		DF-430-18D	DF-430-24D	
1	Cover Assembly	6769	15342	See Note 1 above
2	Deck Ring	6750	15334	Mild Steel
3	Strongback	6300	13870	Galvanized Steel
4	Tee Handle	16993	16993	Stainless Steel
5	Nut	507	507	Brass
6	Gasket	17256	6548	Neoprene
7	Washer	604	604	Brass
8	Washer Gasket	6556	6556	Neoprene
9	Pin	21636	21636	Stainless Steel

MODEL NO.	PART NO.	SIZE	A	B	C	D	WT. (lbs.)
DF-430-18D	6297	18	20-3/4	18	5	3/8	70
	6335 (Galvanized)						74
DF-430-24D	6270	24	26-3/4	24	5	3/8	116
	6289 (Galvanized)						120

* Actual values for above sizes may vary +/- 15% due to variations in materials and tolerances.

Dimensions are in inches unless otherwise noted.

RAISED WATERTIGHT HATCH

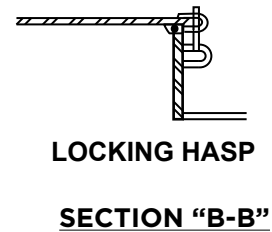
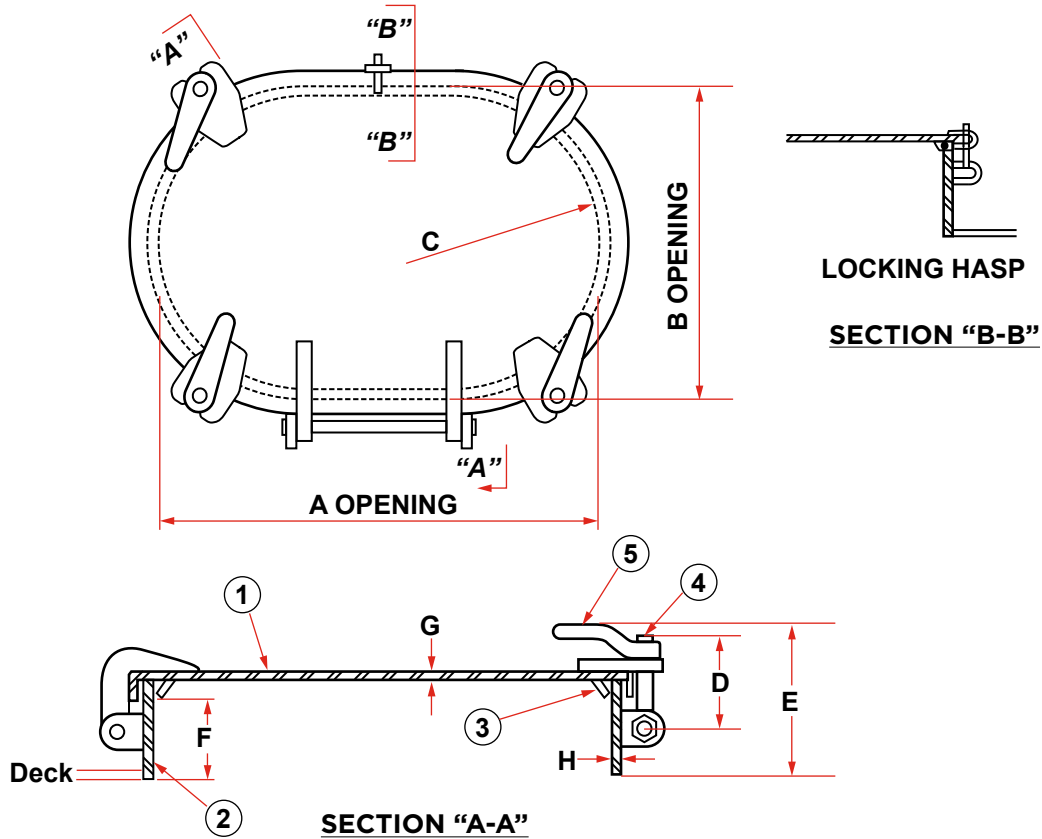

PIECE NO.	DESCRIPTION	PART NUMBER		MATERIAL
		DF-174-5	DF-464-5	
1	Cover Assembly**	77887	78484	Mild Steel
2	Coaming	74897	19551	Mild Steel
3	Gasket	74497	78530	Neoprene†
4	Tumble Bolt	10774	10774	Bronze
5	Dog Handle	74837	74837	Malleable Iron
	Flame Screen*	17051	19445	Stainless Steel

MODEL NO.	PART NO.	SIZE	A	B	C	D	E	F	G	H	WT. (lbs.)
DF-174-5	72451	15 x 23	23	15	7-1/2	5-1/4	8-5/8	5	5/16	3/8	95
DF-464-5	78514	18 x 24	24-1/4	18-1/4	9-1/8	5-1/4	8-5/8	5	5/16	3/8	105

*OPTIONAL EXTRA

** Gasket included w/cover assembly

† Other gasket material available

Other optional extras include galvanized finish, a flame screen and a variety of coaming heights.

The specification and details described by drawings or text in this literature are subject to change without notice.

Dimensions are in inches unless otherwise noted.

RAISED WATERTIGHT HATCH

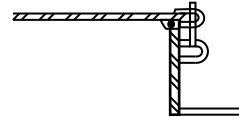
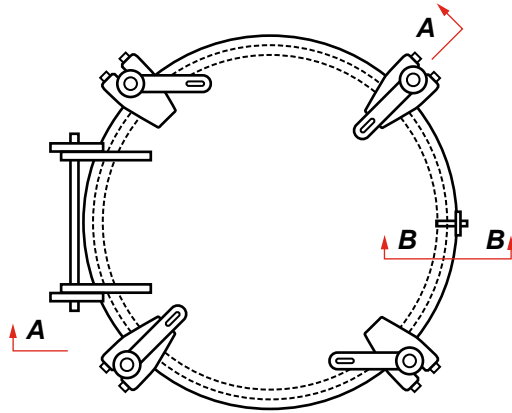

LOCKING HASP

SECTION "B-B"

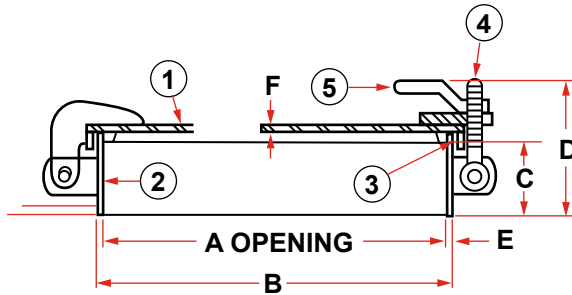

SECTION "A-A"

PIECE NO.	DESCRIPTION	PART NUMBER	MATERIAL
1	Cover Assembly**	77895	Mild Steel
2	Coaming	75026	Mild Steel
3	Gasket	74497	Neoprene†
4	Tumble Bolt	10774	Bronze
5	Dog Handle	74837	Malleable Iron

MODEL NO.	PART NO.	SIZE	A	B	C	D	E	F	WT. (lbs.)
DF-343-5	74950	19	19	19-3/4	5	8-5/8	3/8	5/16	90

*OPTIONAL EXTRA

** Gasket included w/cover assembly

† Other gasket material available

Other optional extras include galvanized finish, a flame screen and a variety of coaming heights.

The specification and details described by drawings or text in this literature are subject to change without notice.

Dimensions are in inches unless otherwise noted.

CLEAN OUT HATCH

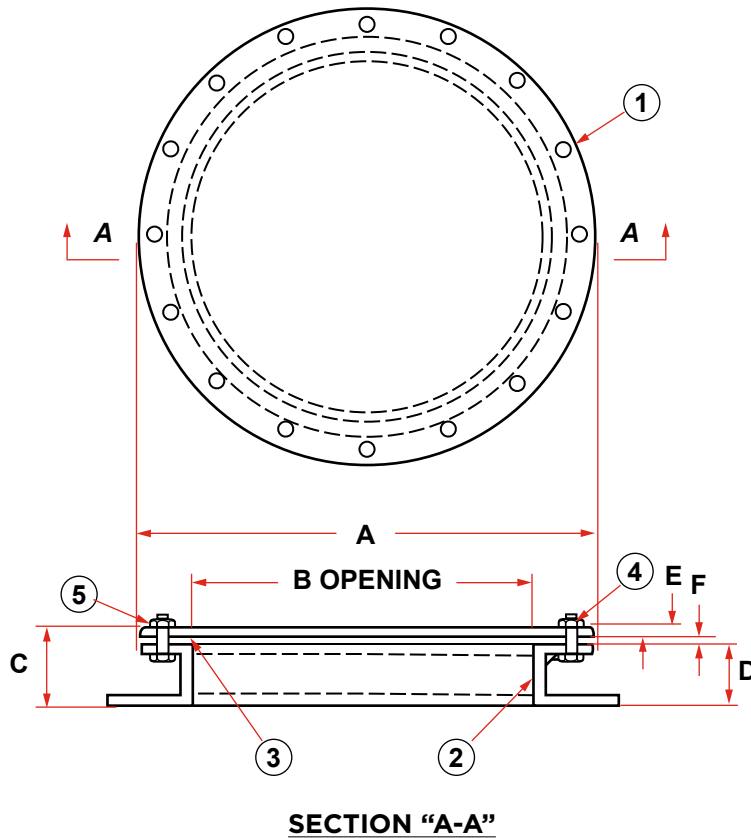

PIECE NO.	DESCRIPTION	PART NUMBER		MATERIAL
		DF-154-18	DF-154-14	
1	HATCH COVER	77216	76767	MILD STEEL
2	COAMING	77232	76783	MILD STEEL
3	GASKET	77224	76775	NEOPRENE
4	5/8" BOLT	14613	14613	STEEL
5	5/8" NUT	16179	16179	BRASS

MODEL NO.	PART NO.	SIZE	A	B	C	D	E	F	WT. (lbs.)
DF-154-14	15407	14	19	14	3-1/4	2-1/2	3/8	3/8	60
DF-154-18	77240	18	23	18	3-1/4	2-1/2	3/8	3/8	78

The specification and details described by drawings or text in this literature are subject to change without notice.

Dimensions are in inches unless otherwise noted.

RAISED BOLTED HATCH

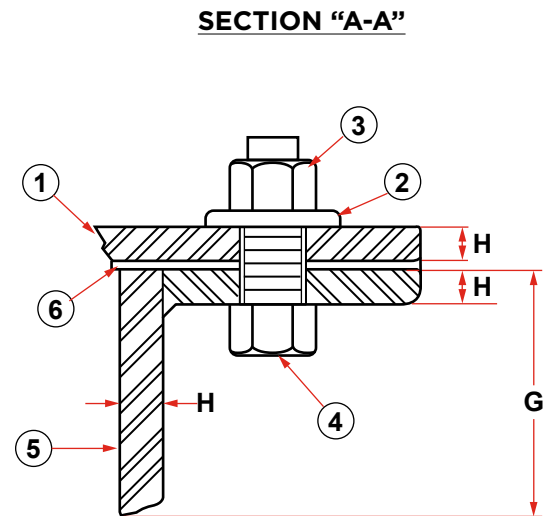
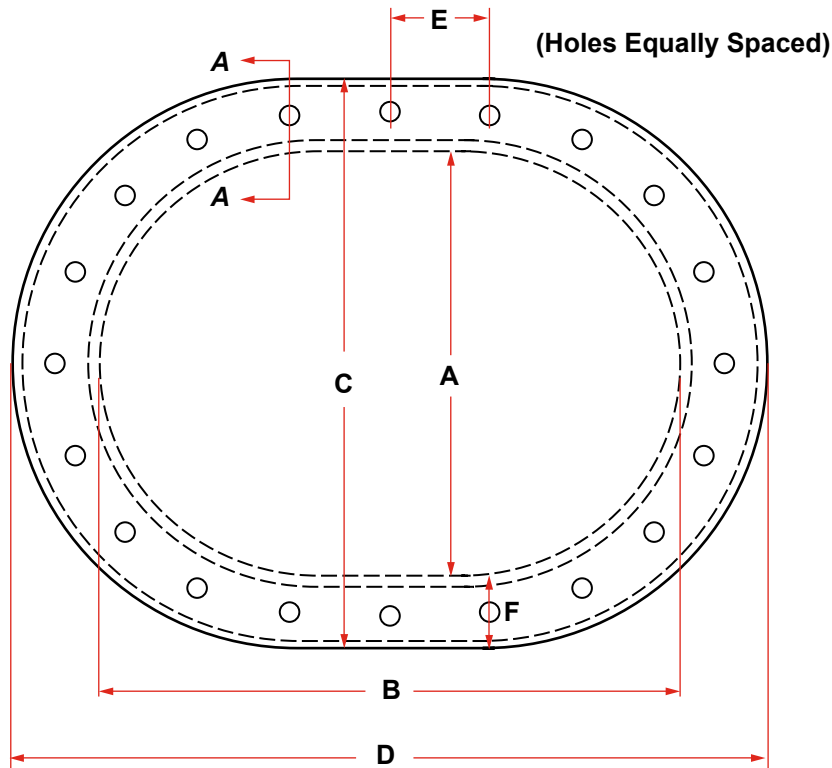

PIECE NO.	DESCRIPTION	PART NUMBER		MATERIAL
		DF-501	DF-502	
1	COVER PLATE	21342	21350	STEEL
2	WASHER	21237	21237	BRASS
3	HEX NUT	21245	21245	STAINLESS
4	HEX BOLT	14605	14605	STEEL
5	COAMING	21369	21377	STEEL
6	GASKET	21385	21393	NEOPRENE

MODEL NO.	PART NO.	SIZE	A	B	C	D	E	F	G	H	WT. (lbs.)
DF-501	21091	15 X 23	15	23	20	28-3/4	3-5/8	2-1/2	2-1/2	3/8	85
DF-502	21105	18 X 24	18	24	23	29-3/4	3-1/4	2-1/2	2-1/2	3/8	106

The specification and details described by drawings or text in this literature are subject to change without notice.

Dimensions are in inches unless otherwise noted.

FLUSH BOLTED HATCH

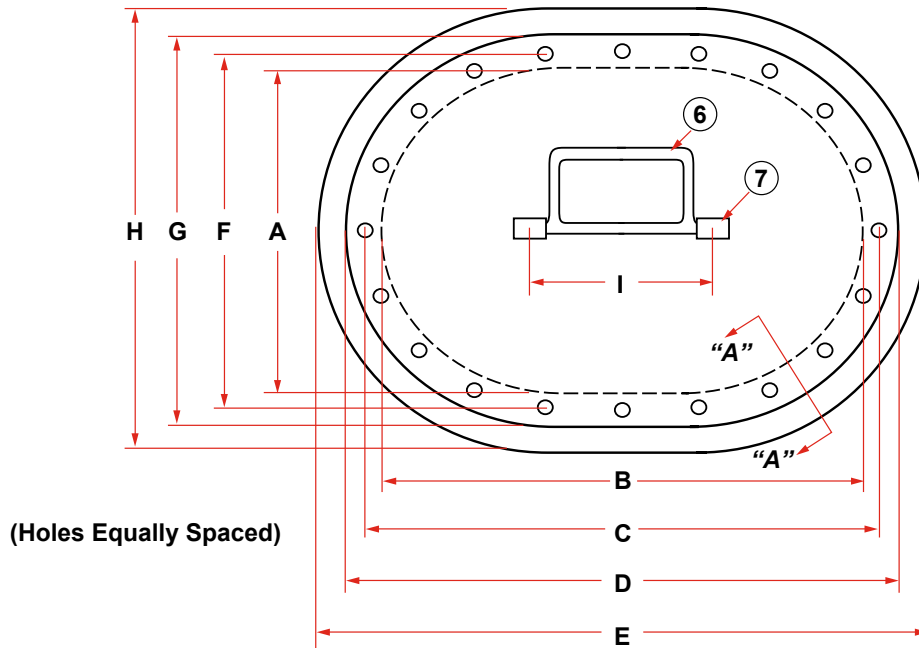

NOTE: Lampwick grommet furnished by others if required.

SECTION "A-A"

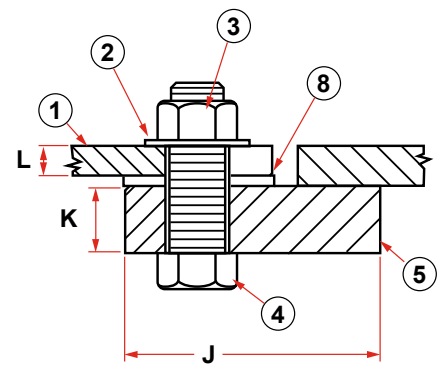

PIECE NO.	DESCRIPTION	PART NUMBER		MATERIAL
		DF-503	DF-504	
1	COVER	21229	21318	MILD STEEL
2	WASHER	21237	21237	BRASS
3	NUT	21245	21245	STAINLESS STEEL
4	BOLT	14613	14613	STEEL
5	DECK RING	21253	21326	MILD STEEL
6	HANDLE	21261	21261	MILD STEEL
7	HANDLE RETAINER	21288	21288	MILD STEEL
8	GASKET	21296	21334	NEOPRENE

MODEL NO.	PART NO.	SIZE	A	B	C	D	E	F	G	H	I	J	K	L	WT. (lbs.)
DF-503	21113	15 X 23	15	23	24-1/4	26-1/2	29	16-1/4	18-1/2	21	9	3	3/4	3/8	95
DF-504	21121	18 X 24	18	24	25-1/4	27-1/2	30	19-1/4	21-1/2	24	9	3	3/4	3/8	112

The specification and details described by drawings or text in this literature are subject to change without notice.

Dimensions are in inches unless otherwise noted.

ULLAGE HATCH

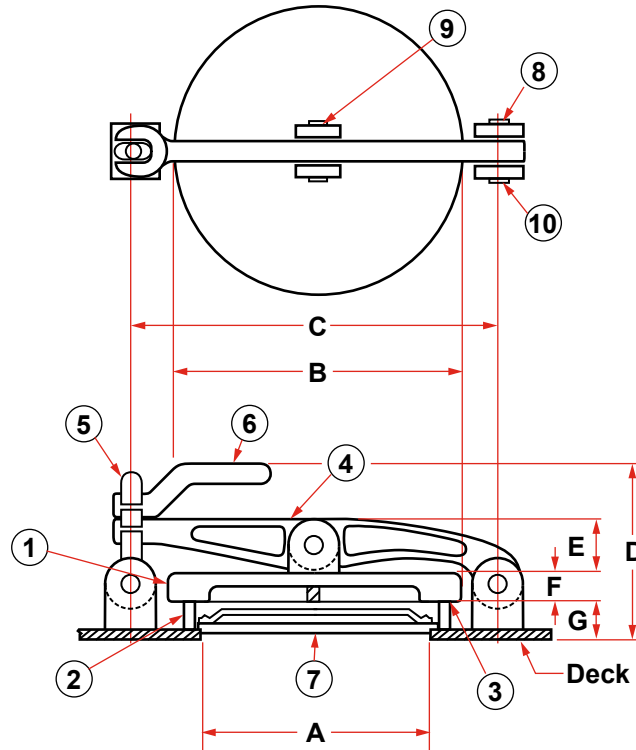

PIECE NO.	DESCRIPTION	PART NUMBER	MATERIAL
1	COVER	6637	CAST IRON
2	COAMING	75671	MILD STEEL
3	GASKET	17167	NEOPRENE
4	ARM	6831	MALLEABLE IRON
5	TUMBLE BOLT	10774	BRONZE
6	DOG HANDLE	74837	MALLEABLE IRON
7	FLAME SCREEN	6629	STAINLESS STEEL
8	HEX HEAD BOLT	20842	BRONZE
9	HEX HEAD BOLT	20850	BRONZE
10	ESNA NUT	20869	STAINLESS

MODEL NO.	PART NO.	SIZE	A	B	C	D	E	F	G	WT. (lbs.)
DF-144	6645	8	7-1/2	9-1/2	12	5-5/16	1-7/8	13/16	7/8	22

The specification and details described by drawings or text in this literature are subject to change without notice.

Dimensions are in inches unless otherwise noted.

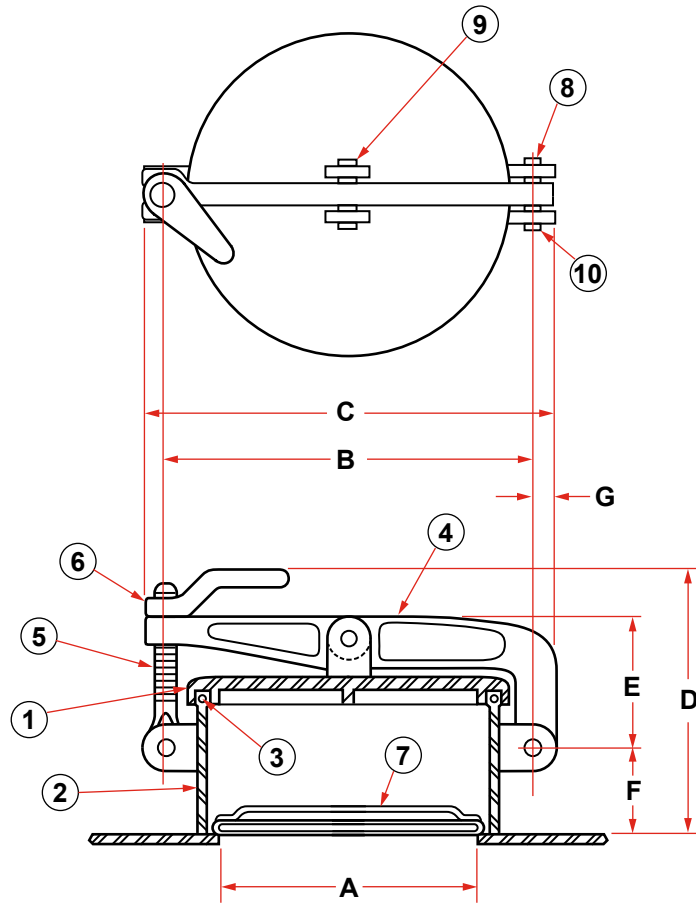

ULLAGE HATCH

PIECE NO.	DESCRIPTION	PART NUMBER	MATERIAL
1	COVER	83062	CAST IRON
2	COAMING	19526	MILD STEEL
3	GASKET	82449	NEOPRENE
4	ARM	19461	MALLEABLE IRON
5	TUMBLE BOLT	10774	BRONZE
6	DOG HANDLE	74837	MALLEABLE IRON
7	FLAME SCREEN	19496	STAINLESS STEEL
8	HEX HEAD BOLT	20842	BRONZE
9	HEX HEAD BOLT	20850	BRONZE
10	ESNA NUT	20869	STAINLESS STEEL

MODEL NO.	PART NO.	SIZE	A	B	C	D	E	F	G	WT. (lbs.)
DF-569	83097	10	9-1/2	13-1/2	14-3/4	9-5/8	4-3/8	3-1/2	3/4	42

The specification and details described by drawings or text in this literature are subject to change without notice.

Dimensions are in inches unless otherwise noted.

EXPANSION TRUNK

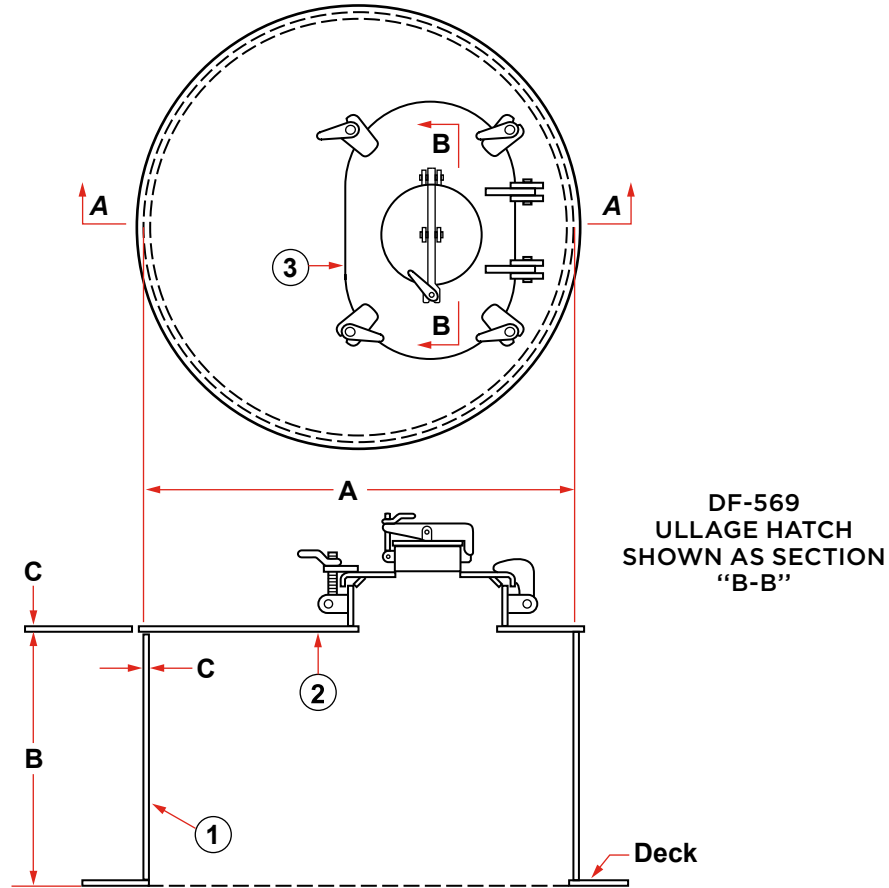

SECTION "A-A"

PIECE NO.	DESCRIPTION	PART NUMBER		MATERIAL
		DF-470	DF-449	
1	COAMING	76171	76171	MILD STEEL
2	COVER	76163	76163	MILD STEEL
3	RAISED HATCH w/ULLAGE HATCH	85316	8214	MILD STEEL

MODEL NO.	PART NO.	SIZE	A	B	C	WT. (lbs.)
DF-449	6238	24 H X 42 Dia W/DF-144	42	24	5/16	520
DF-470	85308	24 H X 42 Dia W/DF-569	42	24	5/16	540

The specification and details described by drawings or text in this literature are subject to change without notice.

Dimensions are in inches unless otherwise noted.

HINGED ROUND-DOGGED TYPE

CLEAR OPENING - 22", TYPE "C" POSITIVE LOCKING

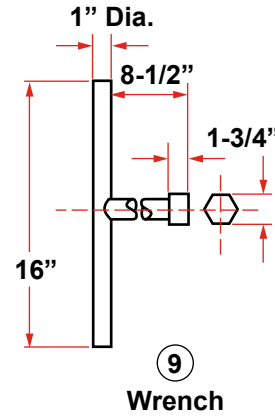
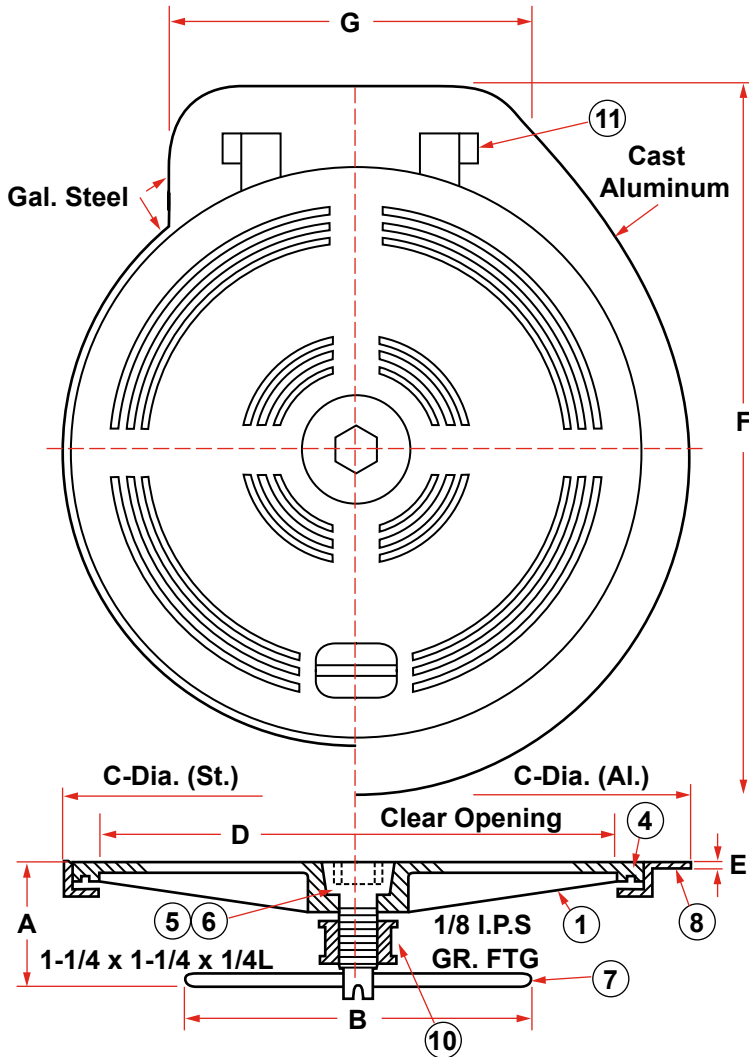

BILL OF MATERIAL		
NO.	DESC.	MAT'L
1	Cover	*
2	Yoke	* 3 arms
3	Bolt	Bronze
4	Gasket	Neoprene
5	Washer	St. Steel
6	Washer	Neoprene
7	Rod-1/2" DIA.	Steel
8	Deck Ring	*
9	Wrench	Galv. Steel
10	Lube Zerk	Anodized Steel
11	Hinge Pin	Stainless Steel
12	Spring	Stainless Steel

*Available in corrosion resistant aluminum or galv. steel

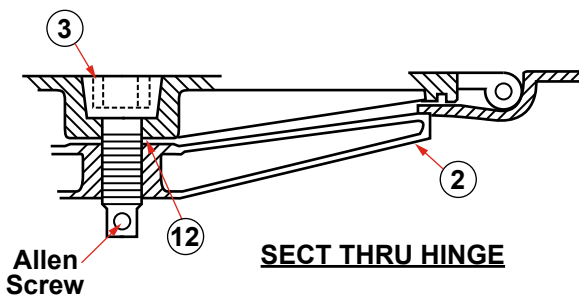

Dimensions are in inches unless otherwise noted.

MODEL NO.	SIZE.	WEIGHT (LBS.)		DIMENSIONS - (INCHES)						
		COVER	RING	A	B	C	D	E	F	G
AL.	22"	21	13	5-1/2	12-1/2	28-1/2	22	1/4	30-1/4	14
ST.		63	27			23-3/4				

WEIGHT ARE FOR ALUMINUM - FOR G. STEEL, MANUF. BY 3.0

HINGED FLUSH TYPE

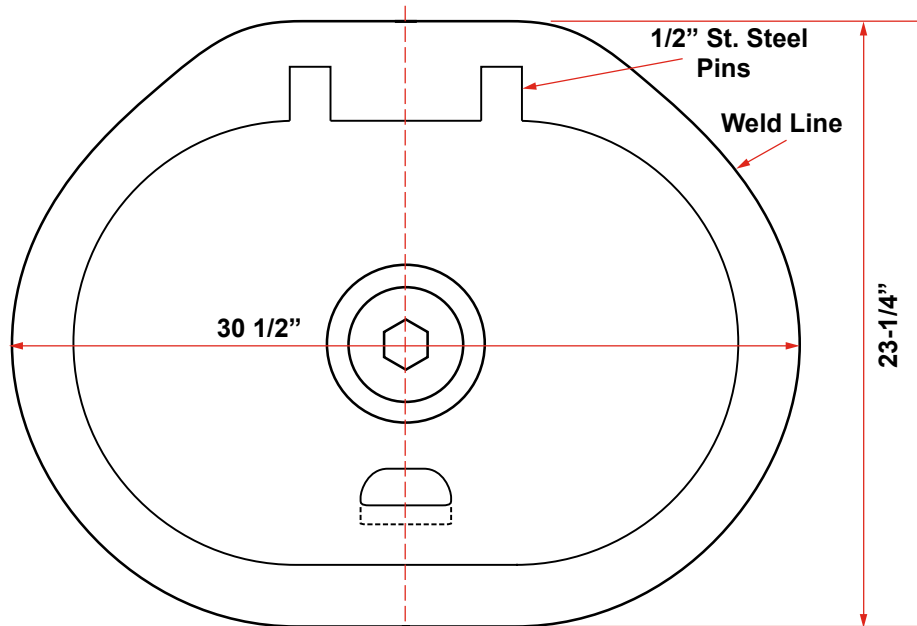

HINGED OVAL DOGGED TYPE
15X24 CLEAR OPENING
TYPE "C" POSITIVE LOCKING

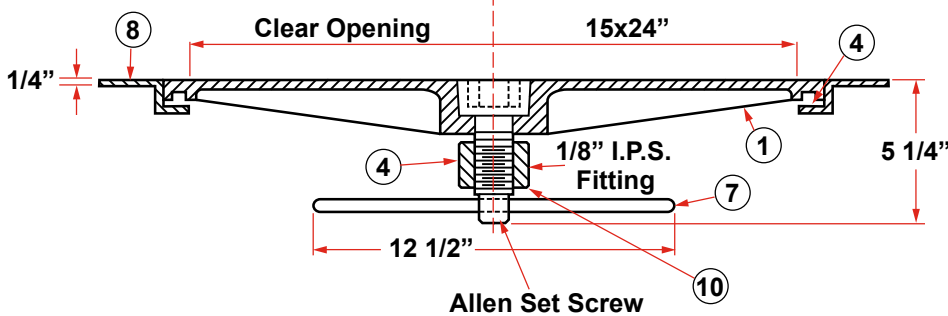

BILL OF MATERIAL		
NO.	DESC.	MAT'L
1	Cover	*
2	Strongback	*
3	Bolt	Bronze
4	Gasket	Neoprene
5	Washer	St. Steel
6	Washer	Neoprene
7	Rod-1/2" ø	Steel
8	Deck Ring	*
9	Wrench	Galv. Steel
10	Lube Zerk	Ann. Steel
11	Hinge Pins	St. Steel

*Available in corrosion resistant aluminum or galv. steel

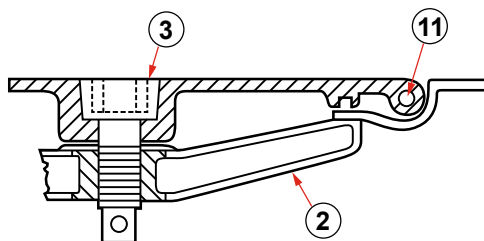

SECT THRU HINGE

Dimensions are in inches unless otherwise noted.

PLAIN FIXED LIGHT DRAWING NO. 500

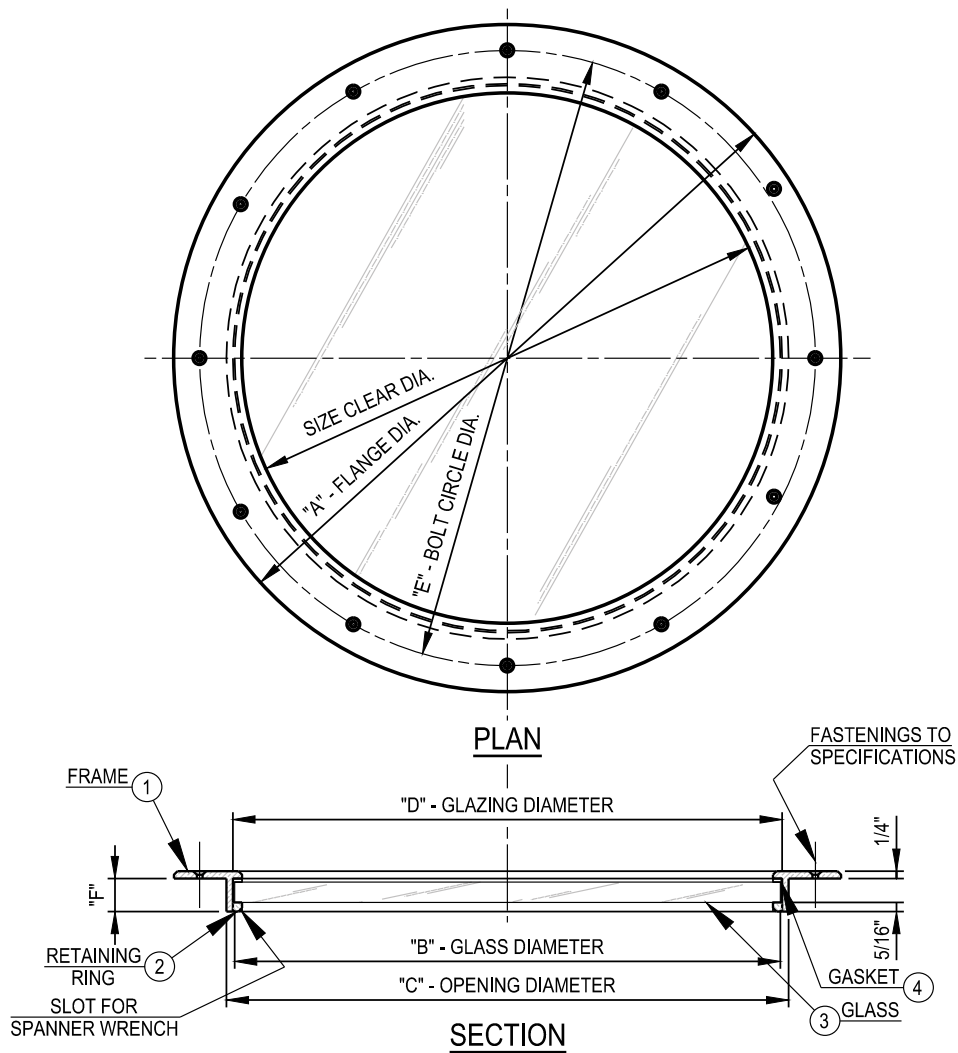

DIMENSION SCHEDULE

SIZE	4	6	7	8	10	12	14	16	18	
DIMENSIONS	A	6-5/8	8-1/2	9-3/4	11	13-1/4	15-1/4	18-1/4	20-5/8	22-5/8
	B	4-3/8 X 3/8	6-3/8 X 1/2	7-3/8 X 3/4	8-1/2 X 3/4	10-1/2 X 3/4	12-1/2 X 3/4	14-1/2 X 3/4	16-1/2 X 3/4	18-1/2 X 3/4
	C	4-13/16	6.800	7-13/16	9-1/16	11-1/16	13-1/16	15-1/16	17-1/16	19-1/16
	D	4-1/2	6-1/2	7-1/2	8-5/8	10-5/8	12-5/8	14-5/8	16-5/8	18-5/8
	E	5-7/8	7-1/2	8-7/8	10-3/8	12-1/4	14-1/4	17	18-7/8	20-7/8
	F	1	1	1	1-1/8	1-1/8	1-1/8	1-3/16	1-3/16	1-3/16
HOLES	6	6	6	8	8	12	12	12	12	
DRILLED FOR	1/4" F.H.	1/4" F.H.	1/4" F.H.	1/4" F.H.	1/4" F.H.	1/4" F.H.	1/4" F.H.	1/4" F.H.	1/4" F.H.	

Dimensions are in inches unless otherwise noted.

**REVERSE FIXED LIGHT
DRAWING NO. 600**

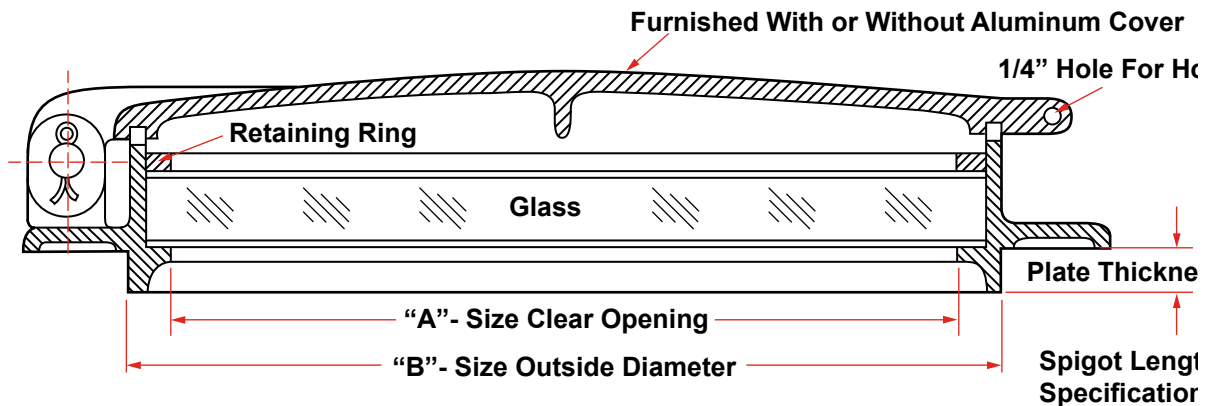
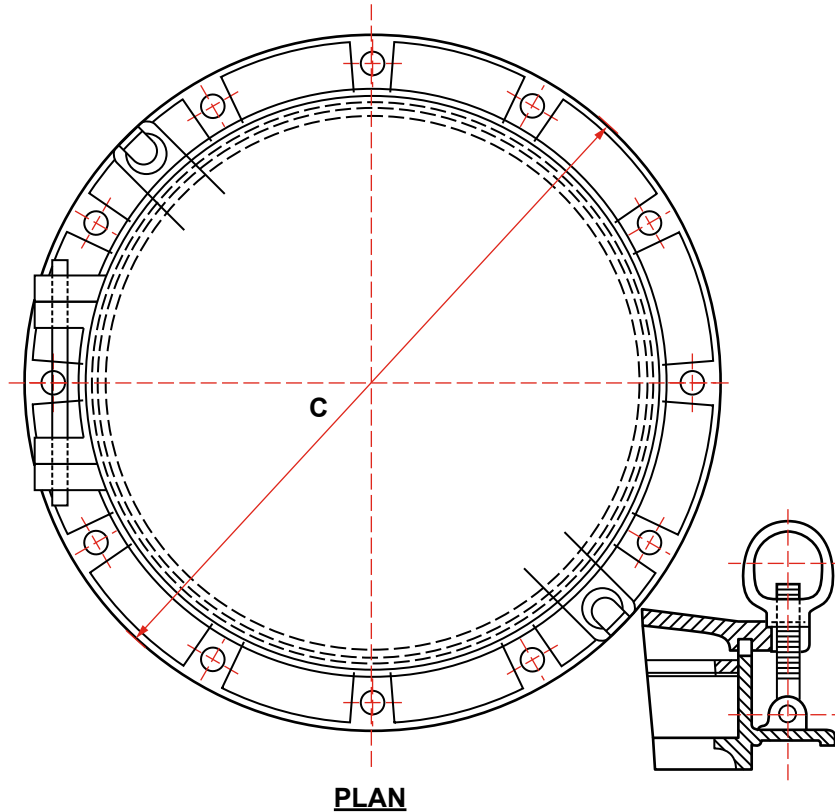

DIMENSION SCHEDULE		
A	B	C
10"	11"	13-5/8"
12"	13-1/8"	15-7/8"
16"	17-1/4"	20-3/8"

Dimensions are in inches unless otherwise noted.

STEEL BACK PORTLIGHT - WELD ON DRAWING NO. 700

SCHEDULE OF MATERIAL

PC. NO.	MATERIAL
1	Aluminum
2	Steel
3	Brass
4	Brass
5	Neoprene
6	Glass
7	Brass
8	Brass
9	Stainless
10	Brass
11	Stainless
12	Stainless
13	Brass
14	Mild Steel
15	Mild Steel
16	Neoprene

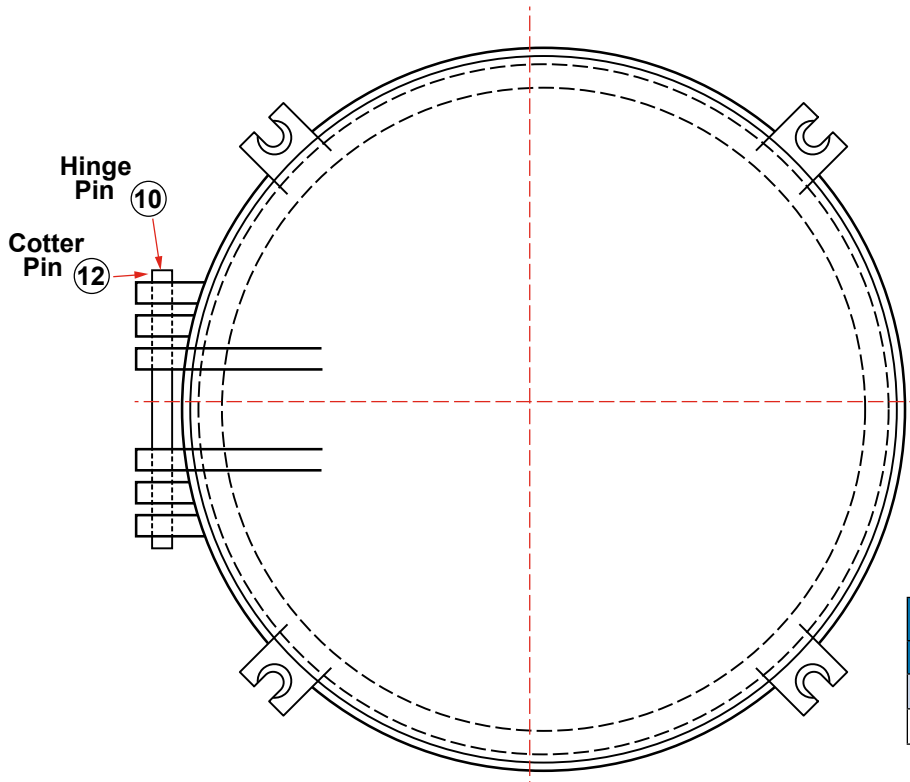

ELEVATION

DIMENSION SCHEDULE						
SIZE	8	10	12	14	16	18
A	8"	10"	12"	14"	16"	18"
B	9-5/8"	11-5/8"	13-5/8"	15-5/8"	17-5/8"	19-5/8"

Dimensions are in inches unless otherwise noted.

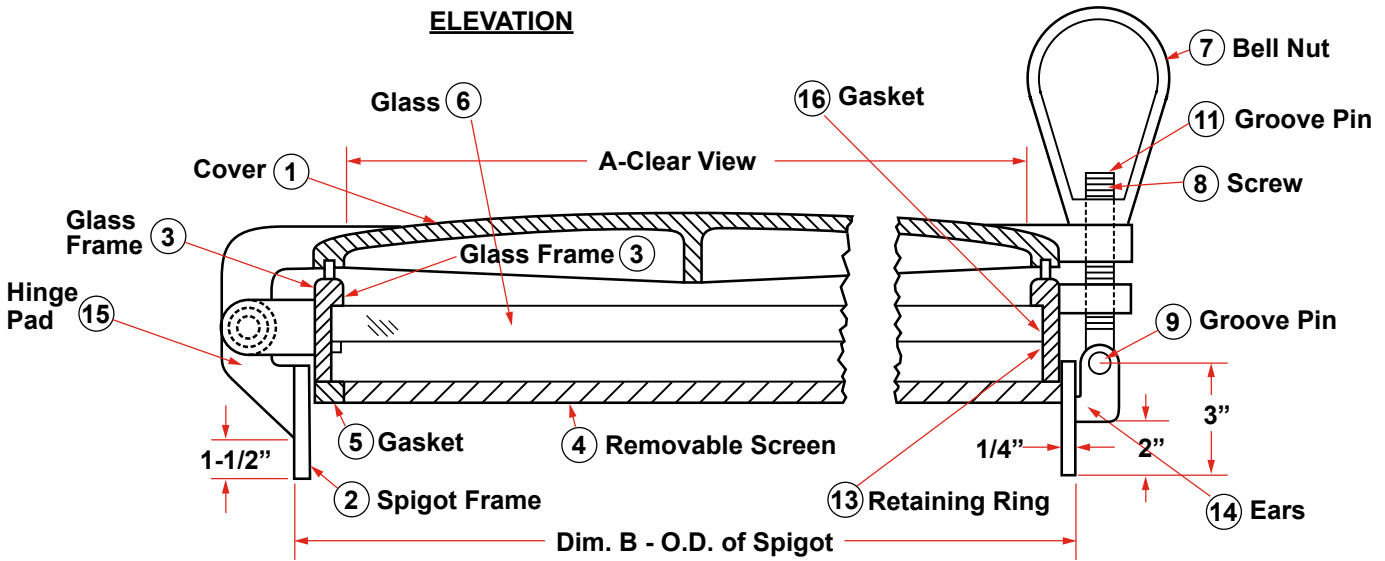

**PORTLIGHT - BOLT ON
DRAWING NO. 800**

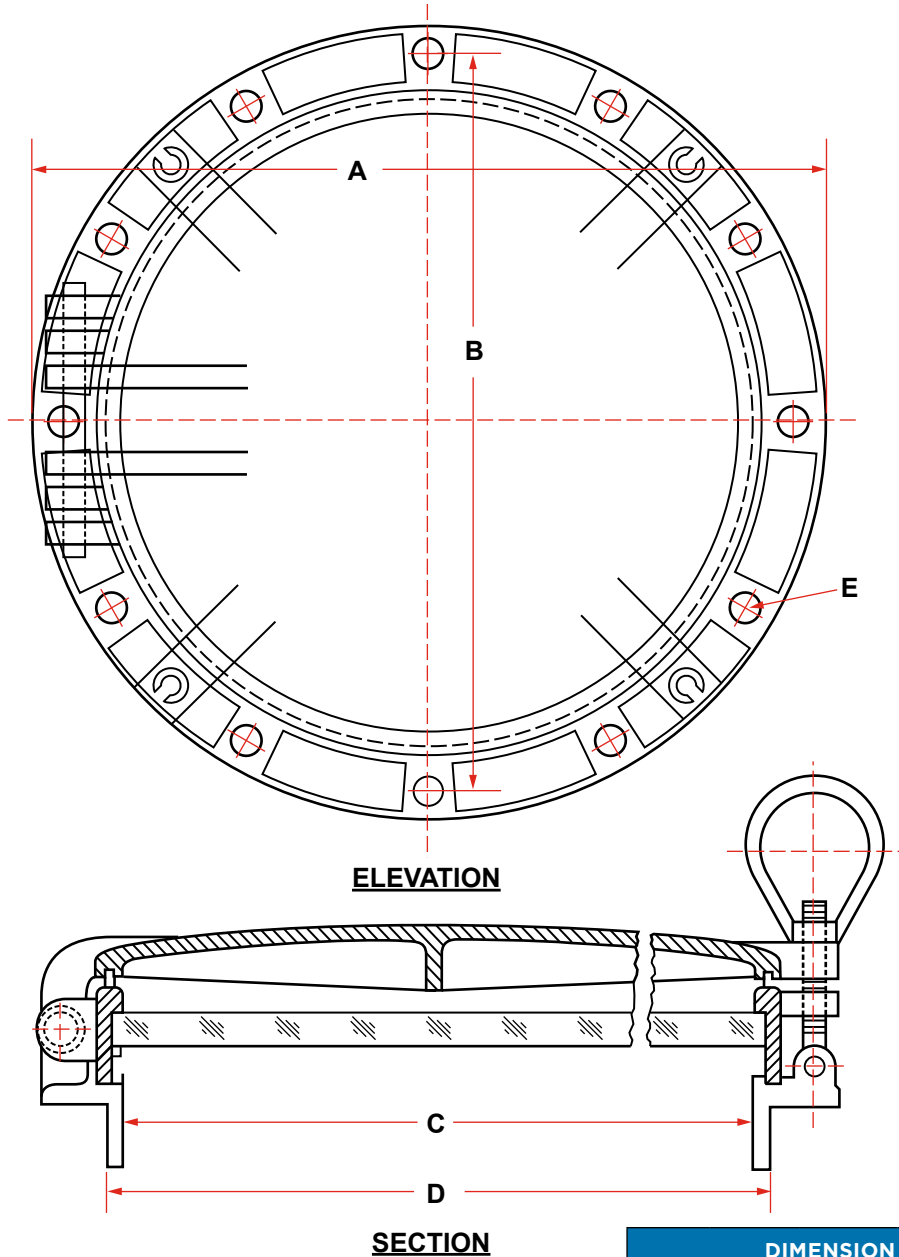

DIMENSION SCHEDULE					
SIZE	10	12	14	16	18
A	14-1/4"	16"	18"	20-3/8"	22-3/4"
B	12-3/4"	14-3/4"	17"	18-7/8"	21-1/8"
C	10"	12"	14"	16"	18"
D	10-3/8"	12-3/8"	14-3/8"	16-1/2"	18-1/2"
E	1/2"	1/2"	1/2"	1/2"	1/2"

Dimensions are in inches unless otherwise noted.

WE PROUDLY SERVICE THE MARINE & OIL INDUSTRY WITH:

- SCUTTLES
- HATCHES
- SINGLE BOLT MANHOLES
- INDIVIDUALLY DOGGED DOORS
- QUICK ACTING DOORS
- BOLTED PLATE MANHOLE
- FIXED LIGHTS
- PORTLIGHTS
- LADDERS
- PLATFORMS
- HANDRAILS
- STRUCTURAL FABRICATION

FABRICATION IN:

- STEEL
- ALUMINUM
- STAINLESS



FENDERS



PNEUMATIC FENDER WITH CHAIN HARNESS



PNEUMATIC SLING TYPE FENDER

SHIP-TO-SHIP APPLICATIONS

INSTALLATION EXAMPLES

Four large-size fenders are usually floated at the water line as primary fenders to absorb impact energy at berthing and keep proper stand-off distance between two ships. Two small-size fenders (secondary fenders) are hung high on the hull at both bow and stern of smaller ship to prevent contact from rolling of ships due to swell and wind. "STS Transfer Guide," published by the International Chamber of Shipping is a good reference for further information.

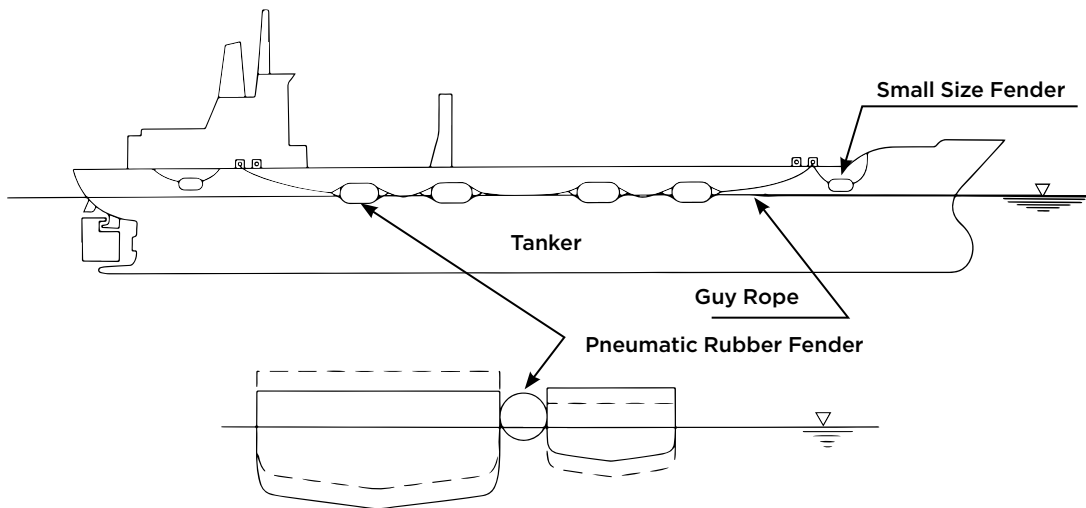

(a) Fenders Rigged in a Continuous String

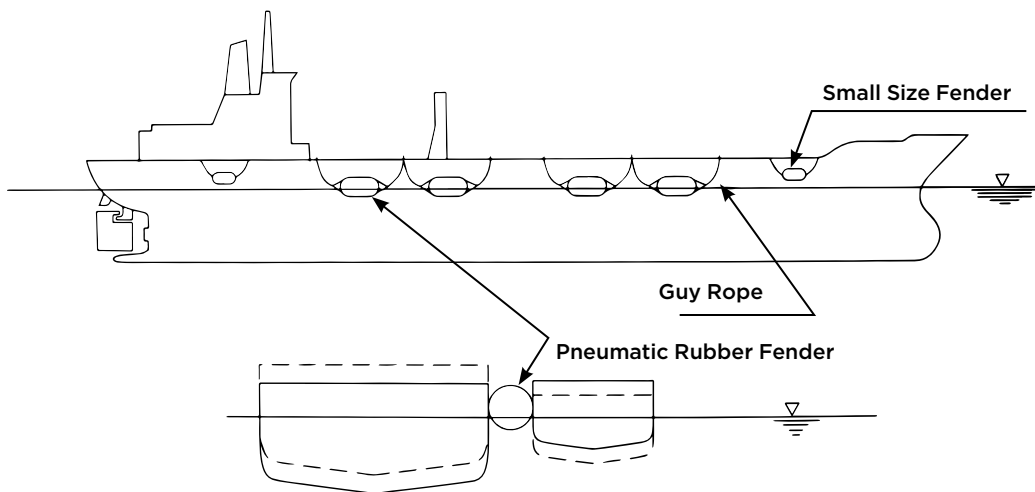

(b) Fenders Guyed Individually

Installation Method in case of Ship-to-Ship Transfer Operations.

Actual Installation Method in case of Ship-to-Ship Transfer Operations.

SHIP-TO-JETTY APPLICATIONS

INSTALLATION METHODS

At both ends of the fender, first shackles, then swivel joints, followed by a further shackle should be installed. A guy chain or guy rope is secured to the outer shackle. The swivel joint prevents twisting of the guy chain or wire.

(a) Dolphin

H.W.L

L.W.L

Anchor
Shackle
End Link

Guy Chain

Rubber Sleeve

End Link
Shackle
Swivel Joint
First Shackle
Towing Ring

Floating-Type
Pneumatic
Rubber Fender

(b) Continuous Quay

H.W.L

L.W.L

Installation Methods
for Ship-to-Jetty
Applications.

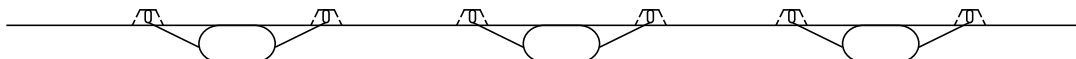

PNEUMATIC 50 (U.S. CUSTOMARY)

PNEUMATIC 50 STANDARD SIZES

NOMINAL SIZE		INITIAL INTERNAL PRESSURE	GUARANTEED ENERGY ABSORPTION (GEA)	REACTION FORCE AT GEA	HULL PRESSURE AT GEA	SAFETY VALUE SETTING PRESSURE	TESTING PRESSURE	WEIGHT OF NET TYPE (TYPE I)				WEIGHT OF SLING TYPE (TYPE II)
DIAMETER X LENGTH								E	R	P	APPROX. FENDER BODY WEIGHT	
(FT X FT)	(MM X MM)	(KIPS)	(KIPS)	(KIPS)	(KIPS/FT ²)	(PSI)	(PSI)	(LBS)	CHAIN NET	WIRE NET	SYNTHETIC FIBER NET	(LBS)
1.6 x 3	500 x 1000	7.3	4.4	14.4	2.72	-	29.0	49	243	66	44	71
2 x 3	600 x 1000	7.3	5.9	16.7	2.59	-	29.0	55	265	66	49	79
2.3 x 5	700 x 1500	7.3	12.5	30.8	2.78	-	29.0	99	331	88	82	121
3 x 5	1000 x 1500	7.3	23.6	41.0	2.51	-	29.0	161	441	176	112	216
3 x 6.5	1000 x 2000	7.3	33.2	57.8	2.72	-	29.0	194	485	309	126	249
4 x 6.5	1200 x 2000	7.3	46.5	66.8	2.59	-	29.0	289	706	419	150	344
4.4 x 8	1350 x 2500	7.3	75.3	96.1	2.67	-	29.0	441	772	441	-	529
5 x 10	1500 x 3000	7.3	113.0	130.0	2.72	-	29.0	551	1169	772	-	639
5.6 x 10	1700 x 3000	7.3	141.0	144.0	2.63	-	29.0	639	1279	970	-	728
6.5 x 11.5	2000 x 3500	7.3	227.0	197.0	2.63	-	29.0	893	2117	1411	-	1025
8 x 13	2500 x 4000	7.3	489.0	311.0	2.82	25.4	36.3	1989	2734	2007	-	2381
8 x 18	2500 x 5500	7.3	696.0	454.0	3.04	25.4	36.3	2403	4079	2558	-	2911
11 x 15	3300 x 4500	7.3	867.0	424.0	2.67	25.4	36.3	3219	3771	2800	-	4057
11 x 21	3300 x 6500	7.3	1339.0	678.0	3.00	25.4	36.3	4123	5667	4212	-	4961
11 x 35	3300 x 10600	7.3	2264.0	1183.0	3.25	25.4	36.3	5645	10275	7277	-	6747
15 x 30	4500 x 9000	7.3	3507.0	1293.0	3.00	25.4	36.3	8688	11885	7762	-	-
15 x 40	4500 x 12000	7.3	4777.0	1796.0	3.17	25.4	36.3	10562	15413	11444	-	-

PNEUMATIC 50 POPULAR NON STANDARD SIZES

NOMINAL SIZE		INITIAL INTERNAL PRESSURE	GUARANTEED ENERGY ABSORPTION (GEA)	REACTION FORCE AT GEA	HULL PRESSURE AT GEA	SAFETY VALUE SETTING PRESSURE	TESTING PRESSURE	WEIGHT OF NET TYPE (TYPE I)				WEIGHT OF SLING TYPE (TYPE II)
DIAMETER X LENGTH								E	R	P	APPROX. FENDER BODY WEIGHT	
(FT X FT)	(MM X MM)	(KIPS)	(KIPS)	(KIPS)	(KIPS/FT ²)	(PSI)	(PSI)	(LBS)	CHAIN NET	WIRE NET	SYNTHETIC FIBER NET	(LBS)
1.3 x 5	400 x 1500	7.3	4.4	19.6	3.11	-	29.0	51	-	-	-	73
2 x 4	600 x 1200	7.3	7.4	20.9	2.72	-	29.0	62	-	-	-	86
2.6 x 4	800 x 1200	7.3	11.8	26.1	2.51	-	29.0	107	529	-	-	128
4 x 6	1200 x 1800	7.3	40.6	59.0	2.51	-	29.0	271	684	-	-	326
4.4 x 11.5	1350 x 3500	7.3	112.0	144.0	2.90	-	29.0	562	1323	-	-	650
5 x 8	1500 x 2500	7.3	90.8	104.0	2.59	-	29.0	487	970	-	-	576
6.5 x 10	2000 x 3000	7.3	188.0	164.0	2.51	-	29.0	809	1985	-	-	942
6.5 x 15	2000 x 4500	7.3	309.0	267.0	2.82	-	29.0	1058	2646	-	-	1191
8 x 25	2500 x 7700	7.3	996.0	664.0	3.23	25.4	36.3	3021	6659	-	-	3528
11 x 28	3300 x 8600	7.3	1803.0	931.0	3.17	25.4	36.3	4895	8181	-	-	5998
15 x 21	4500 x 6400	7.3	2390.0	854.0	2.74	25.4	36.3	7497	8600	-	-	-

PNEUMATIC 80 (U.S. CUSTOMARY)

PNEUMATIC 80 STANDARD SIZES

NOMINAL SIZE		INITIAL INTERNAL PRESSURE	GUARANTEED ENERGY ABSORPTION (GEA)	REACTION FORCE AT GEA	HULL PRESSURE AT GEA	SAFETY VALUE SETTING PRESSURE	TESTING PRESSURE	WEIGHT OF NET TYPE (TYPE I)				WEIGHT OF SLING TYPE (TYPE II)
								APPROX. FENDER BODY WEIGHT	APPROXIMATE WEIGHT OF NET			
DIAMETER X LENGTH		E	R	P			CHAIN NET		WIRE NET	SYNTHETIC FIBER NET		
(FT X FT)	(MM X MM)	(KIPS)	(KIPS)	(KIPS)	(KIPS/FT ²)	(PSI)	(PSI)	(LBS)	(LBS)	(LBS)	(LBS)	(LBS)
1.6 x 3	500 x 1000	11.6	5.9	19.1	3.58	-	36.3	53	243	66	44	75
2 x 3	600 x 1000	11.6	8.1	22.1	3.41	-	36.3	60	265	66	49	84
2.3 x 5	700 x 1500	11.6	17.7	40.5	3.64	-	36.3	104	331	88	82	126
3 x 5	1000 x 1500	11.6	33.2	53.8	3.29	-	36.3	168	441	176	112	223
3 x 6.5	1000 x 2000	11.6	46.5	76.1	3.58	-	36.3	203	485	309	126	258
4 x 6.5	1200 x 2000	11.6	64.9	87.8	3.41	-	36.3	298	706	419	150	353
4.4 x 8	1350 x 2500	11.6	105.0	126.0	3.50	-	36.3	452	772	441	-	540
5 x 10	1500 x 3000	11.6	158.0	171.0	3.58	-	36.3	611	1169	772	-	699
5.6 x 10	1700 x 3000	11.6	197.0	189.0	3.46	-	36.3	697	1279	970	-	785
6.5 x 11.5	2000 x 3500	11.6	317.0	259.0	3.46	-	36.3	911	2139	1521	-	1043
8 x 13	2500 x 4000	11.6	683.0	408.0	3.70	33.4	43.5	2227	2756	2007	-	2624
8 x 18	2500 x 5500	11.6	972.0	597.0	4.01	33.4	43.5	2712	4101	2580	-	3219
11 x 15	3300 x 4500	11.6	1210.0	557.0	3.52	33.4	43.5	3793	3793	2822	-	4608
11 x 21	3300 x 6500	11.6	1869.0	891.0	3.93	33.4	43.5	4851	5689	4388	-	5667
11 x 35	3300 x 10600	11.6	3160.0	1554.0	4.28	33.4	43.5	6681	10275	7277	-	7762
15 x 30	4500 x 9000	11.6	4896.0	1699.0	3.95	33.4	43.5	9658	11995	7894	-	-
15 x 40	4500 x 12000	11.6	6670.0	2360.0	4.16	33.4	43.5	11753	15501	11532	-	-

PNEUMATIC 80 POPULAR NON STANDARD SIZES

NOMINAL SIZE		INITIAL INTERNAL PRESSURE	GUARANTEED ENERGY ABSORPTION (GEA)	REACTION FORCE AT GEA	HULL PRESSURE AT GEA	SAFETY VALUE SETTING PRESSURE	TESTING PRESSURE	WEIGHT OF NET TYPE (TYPE I)				WEIGHT OF SLING TYPE (TYPE II)
								APPROX. FENDER BODY WEIGHT	APPROXIMATE WEIGHT OF NET			
DIAMETER X LENGTH		E	R	P			CHAIN NET		WIRE NET	SYNTHETIC FIBER NET		
(FT X FT)	(MM X MM)	(KIPS)	(KIPS)	(KIPS)	(KIPS/FT ²)	(PSI)	(PSI)	(LBS)	(LBS)	(LBS)	(LBS)	(LBS)
1.3 x 5	400 x 1500	11.6	6.6	25.7	4.09	-	36.3	53	-	-	-	75
2 x 4	600 x 1200	11.6	10.3	27.5	3.58	-	36.3	66	-	-	-	90
2.6 x 4	800 x 1200	11.6	17.0	34.4	3.29	-	36.3	110	529	-	-	132
4 x 6	1200 x 1800	11.6	56.8	77.4	3.29	-	36.3	280	684	-	-	335
4.4 x 11.5	1350 x 3500	11.6	157.0	189.0	3.81	-	36.3	576	1323	-	-	664
5 x 8	1500 x 2500	11.6	126.0	137.0	3.41	-	36.3	538	970	-	-	626
6.5 x 10	2000 x 3000	11.6	263.0	215.0	3.29	-	36.3	827	1985	-	-	959
6.5 x 15	2000 x 4500	11.6	431.0	351.0	3.68	-	36.3	1076	2668	-	-	1208
8 x 25	2500 x 7700	11.6	1391.0	872.0	4.24	33.4	43.5	3418	6681	-	-	3925
11 x 28	3300 x 8600	11.6	2517.0	1223.0	4.16	33.4	43.5	5777	8181	-	-	6858
15 x 21	4500 x 6400	11.6	3335.0	1122.0	3.58	33.4	43.5	8291	8622	-	-	-

SIZES AND PERFORMANCES

The Pneumatic Rubber Fenders are available in the following sizes, which are generally expressed in terms of diameter by length.

Ø4500 x 9000L - P80
Pneumatic Rubber Fender

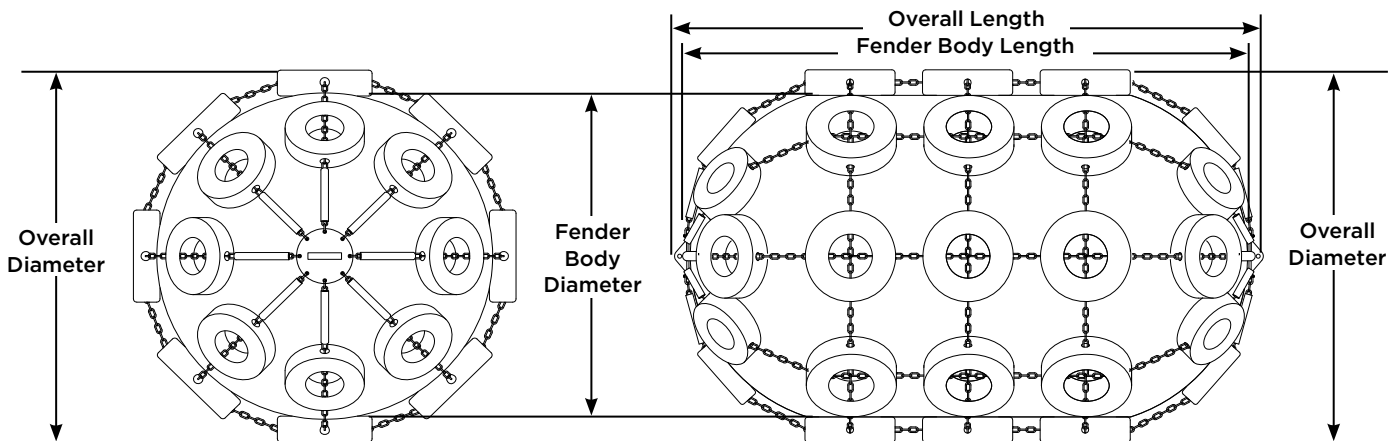
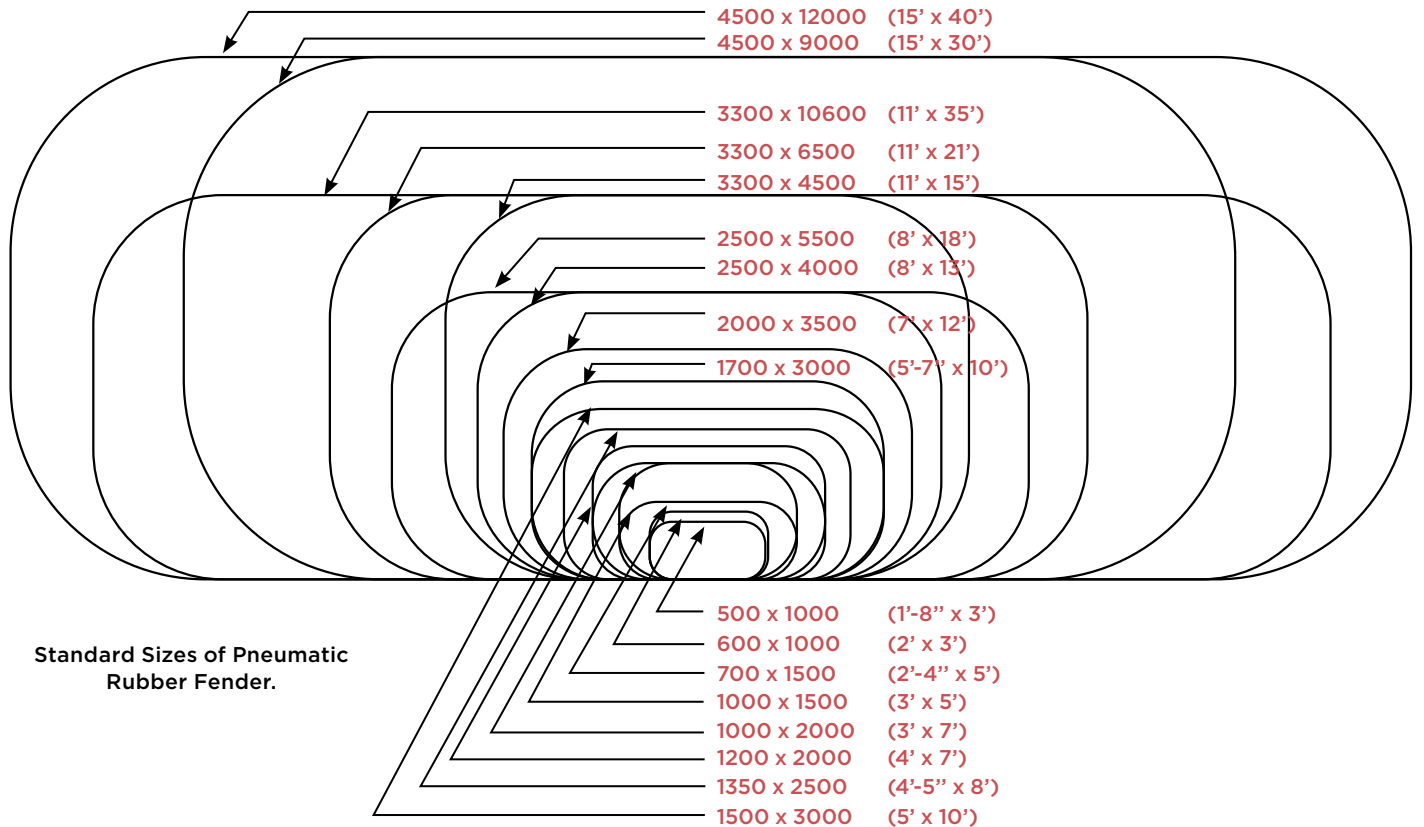

FOAM FILLED FENDERS



OCEAN CUSHION

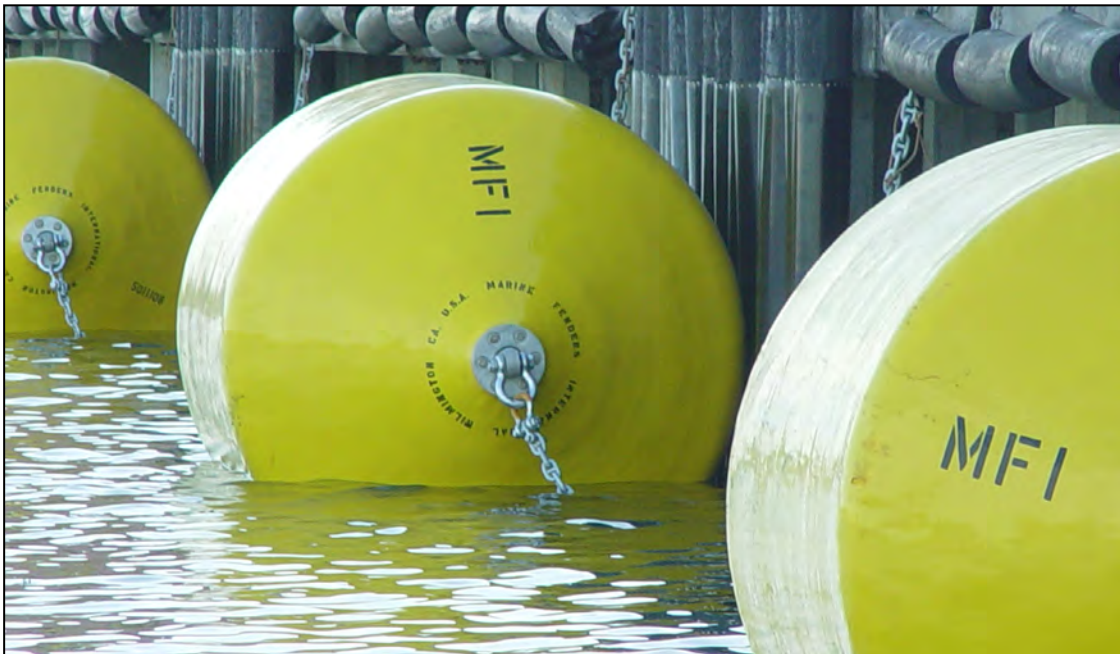

OCEAN GUARD

LOW MAINTENANCE

The design of the foam-filled Ocean Guard™ Netless Fender is highly resistant to environmental hazards such as extreme temperatures, hydrocarbons, fresh and salt water, ozone and ultraviolet radiation. The fender skin is even resistant to chemicals such as diesel fuels.

Additionally, since the internal construction consists of a solid heat laminated foam core, there is no need to maintain air pressure, inflation or relief valves, as with pneumatic fenders.



INSTALLATION

Ocean Guard™ Netless Fenders are designed for easy installation. Their buoyant construction allows the option of a floating installation. The unique end fittings and ultra heavy duty internal chain are also ideal for a fixed hanging installation. Both installations can include a 2-point and 4-point mounting arrangement. Typical mounting hardware includes dock plate padeyes, anchor bolts, shackles, swivels and stud link chain.

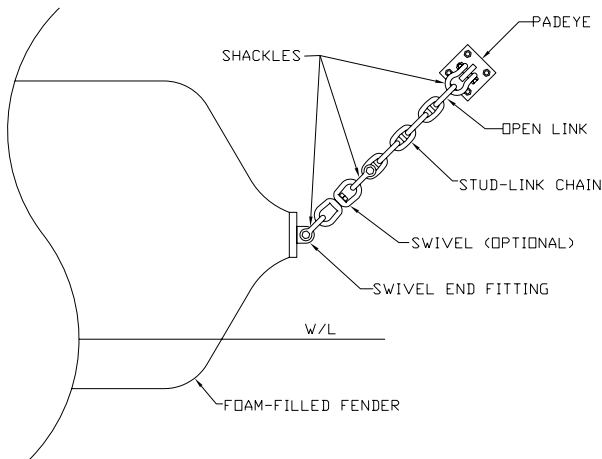

CONSTRUCTION FEATURES

FOAM CORE

Construction begins with a resilient energy absorbing closed cell cross-linked polyethylene foam core which is heat laminated into one piece solid foam core. This heat lamination process produces a thermal bond between the layers of foam which is stronger than the foam itself. It will not delaminate even under the most abusive berthing conditions. This ensures that the foam core construction of the fender will provide years of quality service and performance.

Because of this foam core, if punctured the fender will not experience a catastrophic failure as would pneumatic fenders.

REINFORCED ELASTOMERIC SKIN

The energy absorbing foam core is protected by a tough, thick filament nylon tire cord reinforced elastomer skin. This non-marking reinforced elastomer fender skin is the wear surface of the fender. The reinforcing filaments are continuously wound in a helix pattern through up to 90% of the elastomer skin, and wrap around the fender swivel end fitting housings on each end of the fender. This continuous reinforcement of the elastomer skin not only increases the tensile and tear strength of the elastomer but also distributes loads through the fender skin.

Our elastomer skin exemplifies the latest in urethane technology. This tough, resilient material is specially formulated to withstand the world's harshest conditions, providing superior performance in extreme temperatures, toxic environments, against hydrocarbons, salt water, ozone, and ultraviolet radiation. Its smooth, sleek construction is not prone to snagging on dock or hull protrusions.

URETHANE SKIN AND ENERGY ABSORBING FOAM CORE CONSTRUCTION

Continuous filament nylon tire cord reinforcement in urethane skin Outer wear surface of UV resistant urethane skin Heat laminated polyethylene foam core layers

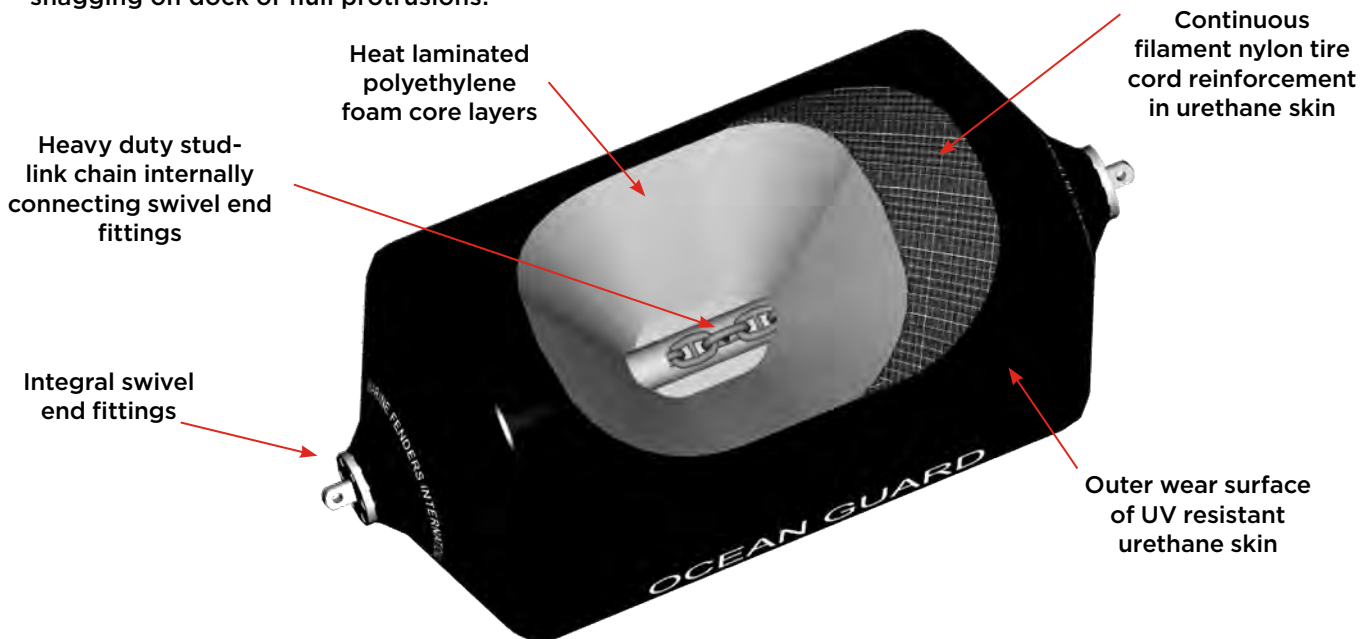
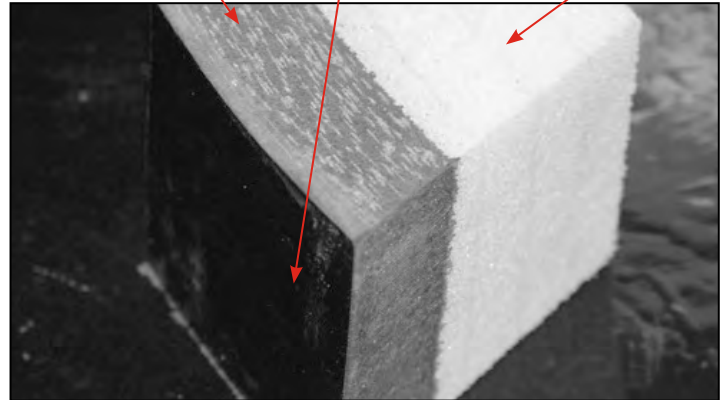

OCEAN GUARD™ NETLESS

FENDERS		LOW REACTION				STANDARD CAPACITY				HIGH CAPACITY				EXTRA HIGH CAPACITY				SUPER HIGH CAPACITY				FENDER	
SIZE		ENERGY ABSORPTION		REACTION FORCE		ENERGY ABSORPTION		REACTION FORCE		ENERGY ABSORPTION		REACTION FORCE		ENERGY ABSORPTION		REACTION FORCE		ENERGY ABSORPTION		REACTION FORCE		SAFE WORKING END PULL LOAD	
ENGLISH	METRIC	FT-KIPS	TON-M	KIPS	TONS	FT-KIPS	TON-M	KIPS	TONS	FT-KIPS	TON-M	KIPS	TONS	FT-KIPS	TON-M	KIPS	TONS	FT-KIPS	TON-M	KIPS	TONS	KIPS	KN
2 x 4	0.6 x 1.2	7	1	12	5	11	2	20	9	14	2	26	12	21	3	38	17	29	4	52	24	9.5	42
3 x 5	0.9 x 1.5	19	3	27	12	31	4	45	20	40	6	59	27	59	9	86	39	81	11	117	53	9.5	42
3 x 6	0.9 x 1.8	23	3	29	13	39	5	48	22	51	7	62	28	71	10	91	41	101	14	125	57	9.5	42
3 x 8	0.9 x 2.4	33	5	41	19	55	8	68	31	72	10	88	40	105	15	129	59	143	20	177	80	17.0	76
4 x 6	1.2x1.8	36	5	34	16	60	8	56	26	78	11	73	33	114	16	106	48	156	22	146	66	17.0	76
4 x 8	1.2 x 2.4	53	7	50	23	89	12	83	38	116	16	108	49	169	23	158	72	231	32	216	98	17.0	76
4 x 10	1.2 x 3.0	71	10	67	30	118	16	111	50	153	21	144	65	224	31	211	96	307	42	289	131	17.0	76
4 x 12	1.2 x 3.7	88	12	82	37	146	20	136	62	190	26	177	80	277	38	258	117	380	53	354	161	24.0	107
5 x 8	1.5 x 2.4	81	11	60	27	135	18	100	45	176	24	130	59	257	36	190	86	351	49	260	118	17.0	76
5 x 10	1.5 x 3.0	108	15	80	37	180	25	134	61	234	32	174	79	342	47	255	116	468	65	348	158	24.0	107
5 x 12	1.5 x 3.7	135	19	100	45	225	31	167	75	293	41	217	98	428	59	317	144	585	81	434	197	24.0	107
5 x 14	1.5 x 4.3	161	22	120	55	269	37	200	91	350	48	260	118	511	71	380	172	699	97	520	236	34.0	151
6 x 12	1.8 x 3.7	180	25	112	50	300	41	186	84	390	54	242	110	570	79	353	160	780	108	484	220	34.0	151
6 x 14	1.8 x 4.3	218	30	135	61	364	50	225	102	473	65	293	133	690	96	428	194	946	131	585	265	34.0	151
6 x 16	1.8 x 4.9	256	35	159	72	427	59	265	120	555	77	345	156	811	112	504	229	1110	154	689	313	50.0	222
7 x 14	2.1 x 4.3	292	40	155	70	487	67	259	117	633	88	337	153	925	128	482	223	1266	175	673	305	50.0	222
7 x 16	2.1 x 4.9	344	47	183	83	574	79	305	138	746	103	397	180	1091	151	580	263	1492	206	793	360	50.0	222
7 x 18	2.1 x 5.5	396	55	211	95	660	91	351	159	858	119	456	207	1254	173	667	303	1716	237	913	414	70.0	311
8 x 12	2.4 x 3.7	319	44	148	67	531	73	246	111	690	95	320	145	1008	139	468	212	1379	191	642	291	70.0	311
8 x 14	2.4 x 4.3	371	51	173	78	619	85	288	130	805	111	374	170	1176	163	547	248	1609	233	749	340	70.0	311
8 x 16	2.4 x 4.9	440	61	205	93	733	101	341	155	953	132	443	201	1393	193	648	294	1906	264	887	402	70.0	311
8 x 18	2.4 x 5.5	508	70	236	107	847	117	394	179	1101	152	512	232	1609	223	749	340	2202	305	1024	464	70.0	311
8 x 20	2.4 x 6.1	577	80	268	122	961	133	447	203	1249	173	581	264	1826	253	849	385	2499	346	1162	527	70.0	311
9 x 14	2.7 x 4.3	467	65	193	88	779	108	322	146	1012	140	418	190	1480	205	611	277	2025	280	837	380	70.0	311
9 x 16	2.7 x 4.9	534	74	221	100	890	123	368	167	1157	160	478	217	1691	234	688	317	2314	320	957	434	70.0	311
9 x 18	2.7 x 5.5	619	86	256	116	1032	143	427	194	1342	186	555	252	1961	271	811	368	2683	371	1110	503	70.0	311
10 x 16	3.0 x 4.9	649	90	241	109	1081	150	402	182	1405	194	523	237	2054	284	764	347	2811	389	1045	474	70.0	311
10 x 18	3.0 x 5.5	755	104	281	127	1258	174	468	212	1635	226	608	276	2390	331	889	403	3271	452	1217	552	70.0	311
10 x 20	3.0 x 6.1	861	119	320	145	1435	198	534	242	1866	258	694	315	2727	377	1015	460	3731	516	1388	630	110.0	489
10 x 24	3.0 x 7.3	1087	150	404	184	1811	250	674	306	2286	316	850	386	3341	462	1244	564	4572	632	1702	772	110.0	489
11 x 18	3.4 x 5.5	889	131	301	159	1482	219	501	265	1927	267	651	295	2816	389	952	432	3853	533	1303	591	110.0	489
11 x 20	3.4 x 6.1	1018	145	344	167	1696	241	573	279	2141	296	745	338	3223	446	1090	494	4410	610	1491	676	110.0	489
12 x 20	3.7 x 6.1	1298	179	425	193	2163	299	708	321	2812	389	920	417	4109	568	1346	611	5623	778	1841	835	110.0	489
13 x 26	4.0 x 7.9	1944	269	591	268	3240	448	985	447	4212	583	1281	581	6156	815	1872	849	8424	1165	2561	1162	110.0	489
14 x 28	4.3 x 8.5	2400	332	678	308	4000	553	1130	513	5200	719	1469	665	7600	1051	2147	974	10400	1438	2938	1333	110.0	489

Custom sizes and capacities available

* Actual values for above sizes may vary +/- 15% due to variations in materials, speed of compression, temperatures and tolerances. Performance based on 60% compression.

OCEAN GUARD™ NETLESS

FENDERS		LOW REACTION				STANDARD CAPACITY				HIGH CAPACITY			
SIZE		ENERGY ABSORPTION		REACTION FORCE		ENERGY ABSORPTION		REACTION FORCE		ENERGY ABSORPTION		REACTION FORCE	
METRIC	ENGLISH	FT-KIPS	TON-M	KIPS	TONS	FT-KIPS	TON-M	KIPS	TONS	FT-KIPS	TON-M	KIPS	TONS
M X M	FT X FT												
0.7 x 1.5	2.3 x 4.9	11	2	18	8	19	3	30	14	25	3	39	18
0.7 x 2.0	2.3 x 6.5	17	2	27	12	28	4	44	20	33	5	52	24
0.7 x 3.0	2.3 x 9.8	29	4	46	21	49	7	77	35	50	7	78	35
1.0 x 1.5	3.3 x 4.9	21	3	18	8	35	5	39	18	46	6	51	23
1.0 x 2.0	3.3 x 6.5	30	4	34	15	50	7	57	26	65	9	74	34
1.0 x 3.0	3.3 x 9.8	53	7	58	26	89	12	97	44	75	10	86	74
1.2 x 2.0	3.9 x 6.5	40	6	38	17	67	9	63	29	87	12	82	37
1.2 x 2.5	3.9 x 8.2	56	8	52	23	94	13	86	39	109	15	103	46
1.35 x 2.5	4.4 x 8.2	67	9	56	25	112	15	94	43	146	20	122	55
1.35 x 3.0	4.4 x 9.8	86	12	71	32	144	20	118	54	175	24	146	66
1.5 x 3.0	4.9 x 9.8	103	14	78	35	171	24	130	59	222	31	169	77
1.7 x 3.0	5.6 x 9.8	125	17	83	38	208	29	139	63	270	37	181	82
1.7 x 4.5	5.6 x 14.7	212	29	139	63	354	49	232	105	360	50	241	109
2.0 x 3.5	6.5 x 11.5	201	28	114	52	335	46	190	86	436	60	247	112
2.0 x 4.0	6.5 x 13.1	239	33	136	62	398	55	226	103	517	72	294	133
2.0 x 4.5	6.5 x 14.7	276	38	157	71	460	64	261	118	598	83	339	154
2.5 x 4.0	8.2 x 13.1	335	46	161	73	591	82	269	122	768	106	350	159
2.5 x 4.5	8.2 x 16.4	398	55	181	82	663	92	301	137	1046	145	475	215
2.5 x 5.5	8.2 x 18.0	531	73	241	109	885	122	402	182	1151	159	523	237
3.0 x 4.9	9.8 x 16.0	633	88	239	108	1055	146	339	154	1372	190	519	235
3.0 x 6.0	9.8 x 19.7	819	113	310	141	1365	189	516	234	1775	245	671	304
3.0 x 7.0	9.8 x 23.0	973	135	367	166	1621	224	611	277	1923	266	727	330
3.3 x 4.5	10.8 x 14.7	663	92	228	103	1105	153	380	172	1437	199	494	224
3.3 x 6.5	10.8 x 21.3	1072	148	368	167	1786	247	614	279	2322	321	798	362
3.3 x 8.5	10.8 x 27.9	1498	207	516	234	2496	345	860	390	2323	321	799	362
3.3 x 10.6	10.8 x 34.8	1909	264	656	298	3181	440	1094	496	4135	572	1422	645

FENDER PRESSURE AT 60% DEFLECTION			
CAPACITY	ENGLISH UNITS KIPS/SQ FT	METRIC UNITS TONS/SQ METER	METRIC UNITS KN/SQ METER
Low Reaction	2.2	10.6	104
Enhanced	2.9	14.1	138
Standard	3.6	17.6	172
Advanced	4.1	20.2	198
High Capacity	4.7	22.9	224
Advanced High	5.8	28.2	276
Extra High Capacity	6.8	33.4	327
Advanced Extra High	8.1	39.6	388
Super High Capacity	9.4	45.7	449
Advanced Super High	10.8	52.7	517
Ultra High	12.2	59.7	586

GENERIC PERFORMANCE CURVE
OCEAN GUARD FENDER

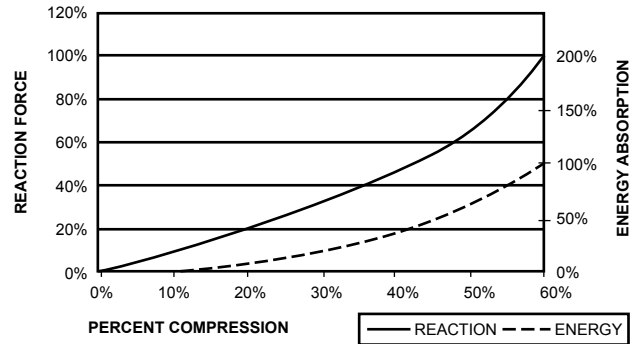

FENDERS		EXTRA HIGH CAPACITY				SUPER HIGH CAPACITY				ULTRA HIGH CAPACITY				FENDER	
SIZE		ENERGY ABSORPTION		REACTION FORCE		ENERGY ABSORPTION		REACTION FORCE		ENERGY ABSORPTION		REACTION FORCE		SAFE WORKING END PULL LOAD	
METRIC	ENGLISH	FT-KIPS	TON-M	KIPS	TONS	FT-KIPS	TON-M	KIPS	TONS	FT-KIPS	TON-M	KIPS	TONS	KIPS	KN
M X M	FT X FT														
0.7 x 1.5	2.3 x 4.9	36	5	57	26	49	7	78	35	65	9	102	46	10	42
0.7 x 2.0	2.3 x 6.5	48	7	76	34	65	9	104	47	96	13	151	68	10	42
0.7 x 3.0	2.3 x 9.8	72	10	114	52	98	14	156	71	167	23	261	118	10	42
1.0 x 1.5	3.3 x 4.9	67	9	74	34	91	13	123	56	119	16	133	60	10	42
1.0 x 2.0	3.3 x 6.5	95	13	108	49	130	18	148	67	170	24	194	88	10	42
1.0 x 3.0	3.3 x 9.8	75	10	86	39	75	10	86	39	303	42	330	150	10	42
1.2 x 2.0	3.9 x 6.5	127	18	120	54	174	24	164	74	228	32	214	97	17	76
1.2 x 2.5	3.9 x 8.2	159	22	150	68	218	30	205	93	320	44	292	133	17	76
1.35 x 2.5	4.4 x 8.2	213	29	179	81	291	40	244	111	381	53	320	145	17	76
1.35 x 3.0	4.4 x 9.8	256	35	215	97	349	48	293	133	490	68	401	182	17	76
1.5 x 3.0	4.9 x 9.8	325	45	247	112	445	62	338	153	581	80	442	200	24	107
1.7 x 3.0	5.6 x 9.8	395	55	264	120	541	75	361	164	707	98	473	214	24	107
1.7 x 4.5	5.6 x 14.7	527	73	352	160	721	100	481	218	1204	166	789	358	24	107
2.0 x 3.5	6.5 x 11.5	637	88	361	164	871	120	494	224	1139	158	646	293	34	151
2.0 x 4.0	6.5 x 13.1	756	105	429	195	1035	143	588	267	1353	187	768	349	34	151
2.0 x 4.5	6.5 x 14.7	874	121	496	225	1196	165	679	308	1564	216	887	403	50	222
2.5 x 4.0	8.2 x 13.1	1123	155	511	232	1573	213	699	317	2009	278	915	415	70	311
2.5 x 4.5	8.2 x 16.4	1529	211	694	315	2091	289	950	431	2254	312	1023	464	70	311
2.5 x 5.5	8.2 x 18.0	1682	233	764	347	2301	318	1045	474	3009	416	1367	620	70	311
3.0 x 4.9	9.8 x 16.0	2005	277	758	344	2743	379	1037	470	3587	496	1153	523	70	311
3.0 x 6.0	9.8 x 19.7	2594	359	980	445	3549	491	1342	609	4641	642	1754	796	110	489
3.0 x 7.0	9.8 x 23.0	2810	389	1062	482	3845	532	1454	659	5511	762	2077	942	110	489
3.3 x 4.5	10.8 x 14.7	2100	290	722	327	2873	397	988	448	3757	520	1292	586	110	489
3.3 x 6.5	10.8 x 21.3	3393	469	1167	529	4644	642	1596	724	6072	840	2088	947	110	489
3.3 x 8.5	10.8 x 27.9	3394	469	1168	530	4645	642	1597	724	8486	1174	2924	1326	110	489
3.3 x 10.6	10.8 x 34.8	6044	836	2079	943	8271	1144	2844	1290	10815	1496	3720	1687	110	489

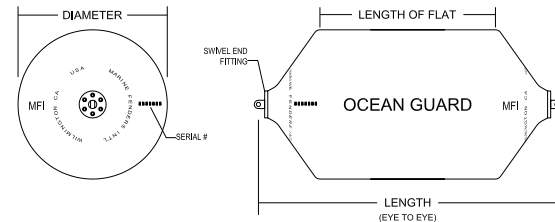

Custom sizes and capacities available

* Actual values for above sizes may vary +/- 15% due to variations in materials, speed of compression, temperatures and tolerances. Performance based on 60% compression.

OCEAN CUSHION™ STANDARD CAPACITY FOAM FILLED FENDER WITH CHAIN & AIRCRAFT TIRE NETS

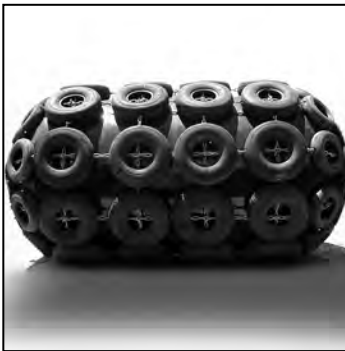

ENGLISH SIZES											
FENDERS		STAND OFF		STANDARD CAPACITY				HIGH CAPACITY			
SIZE		DIAMETER UNCOMPRESSED		ENERGY ABSORPTION		REACTION FORCE		ENERGY ABSORPTION		REACTION FORCE	
ENGLISH	METRIC										
FT X FT	M X M	FT	M	FT -KIPS	TON-M	KIPS	TONS	FT-KIPS	TON-M	KIPS	TONS
3 x 6	0.92 x 1.83	4.1	1.2	36	5	55	25	52	7	79	36
4 x 6	1.22 x 1.83	5.3	1.6	65	9	72	33	94	13	103	47
4 x 8	1.22 x 2.44	5.3	1.6	85	12	98	44	123	17	138	63
5 x 10	1.53 x 3.05	6.5	2.0	165	23	152	69	239	33	214	97
5 x 16	1.53 x 4.88	6.5	2.0	259	36	240	109	375	52	338	153
6 x 12	1.83 x 3.66	7.5	2.3	295	41	217	98	428	59	306	139
7 x 14	2.13 x 4.27	8.5	2.6	450	62	260	118	652	90	366	166
8 x 12	2.44 x 3.66	9.8	3.0	465	64	268	122	674	93	377	171
8 x 16	2.44 x 4.88	9.8	3.0	662	95	380	172	959	133	535	243
9 x 14	2.75 x 4.27	10.8	3.3	730	101	373	169	1058	146	525	238
9 x 18	2.75 x 5.49	10.8	3.3	937	130	480	218	1358	188	676	307
10 x 16	3.05 x 4.88	11.8	3.6	976	135	450	204	1414	196	634	287
10 x 20	3.05 x 6.10	11.8	3.6	1286	179	590	268	1864	258	831	377
11 x 18	3.35 x 5.49	12.8	3.9	1386	192	581	264	2009	278	818	371
11 x 22	3.35 x 6.71	12.8	3.9	1697	235	711	323	2459	340	1001	454
12 x 24	3.70 x 7.30	13.8	4.2	2196	304	844	383	3183	440	1189	539
13 x 26	3.96 x 7.90	14.8	4.5	2785	385	987	448	4036	558	1390	631
14 x 28	4.27 x 8.53	15.8	4.8	3421	473	1128	512	4958	686	1589	721

PERFORMANCE AT 60% COMPRESSION



METRIC SIZES											
FENDERS		STAND OFF		STANDARD CAPACITY				HIGH CAPACITY			
SIZE		DIAMETER UNCOMPRESSED		ENERGY ABSORPTION		REACTION FORCE		ENERGY ABSORPTION		REACTION FORCE	
METRIC	ENGLISH										
M X M	FT X FT	FT	M	FT-KIPS	TON-M	KIPS	TONS	FT-KIPS	TON-M	KIPS	TONS
1.00 x 1.50	3.3 x 4.9	4.4	1.3	35	5	50	23	50	7	71	32
1.00 x 2.00	3.3 x 6.6	4.4	1.3	49	7	67	30	71	10	96	43
1.20 x 2.00	3.9 x 6.6	5.3	1.6	64	9	76	34	93	13	107	49
1.20 x 2.50	3.9 x 8.2	5.3	1.6	80	11	94	43	116	16	132	60
1.35 x 2.50	4.4 x 8.2	5.9	1.8	103	14	108	49	150	21	152	69
1.35 x 4.00	4.4 x 13.1	5.9	1.8	165	23	172	478	239	33	242	110
1.50 x 3.00	4.9 x 9.8	6.4	2.0	156	22	146	66	226	31	206	93
1.70 x 3.00	5.6 x 9.8	7.1	2.2	196	27	162	73	284	39	227	103
1.70 x 4.50	5.6 x 14.8	7.1	2.2	297	41	244	111	430	60	344	156
2.00 x 3.50	6.6 x 11.5	8.1	2.5	318	44	222	101	461	64	313	142
2.00 x 4.00	6.6 x 13.1	8.1	2.5	371	51	259	117	538	74	365	165
2.20 x 4.50	7.2 x 14.8	8.7	2.7	500	69	321	146	725	100	452	205
2.20 x 5.50	7.2 x 18.0	8.7	2.7	609	84	390	177	883	122	549	249
2.50 x 4.00	8.2 x 13.1	10.0	3.0	542	75	305	138	786	109	430	195
2.50 x 5.50	8.2 x 18.0	10.0	3.0	793	110	447	203	1149	159	629	285
3.00 x 6.00	9.8 x 19.7	11.6	3.5	1213	168	571	259	1758	243	804	365
3.30 x 4.50	10.8 x 14.8	12.6	3.8	1010	140	430	195	1464	202	606	275
3.30 x 6.50	10.8 x 21.3	12.6	3.8	1581	219	675	306	2291	317	9511	431
3.30 x 10.6	10.8 x 34.8	12.6	3.8	2774	384	1185	538	4020	556	1669	757
4.20 x 8.40	13.8 x 27.6	15.6	4.8	3325	460	1110	503	4819	666	1563	709

PERFORMANCE AT 60% COMPRESSION

* Actual values for above sizes may vary +/- 15% due to variations in materials, speed of compression, temperatures and tolerances. Performance based on 60% compression.

Ocean Cushion foam filled fenders are also available in other sizes and capacity models, Low Reaction, High, Extra High, and Super High Capacity.



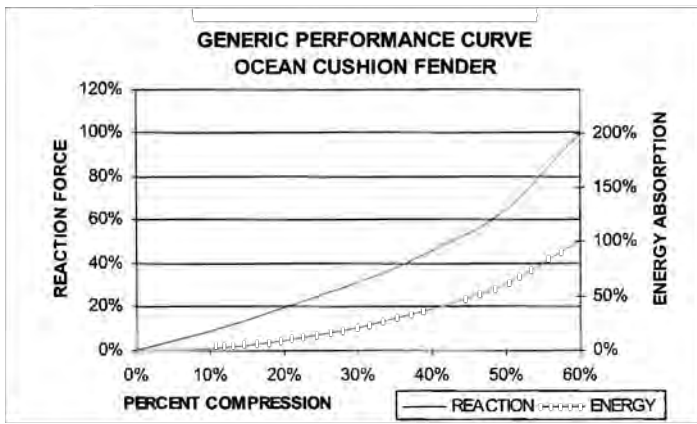
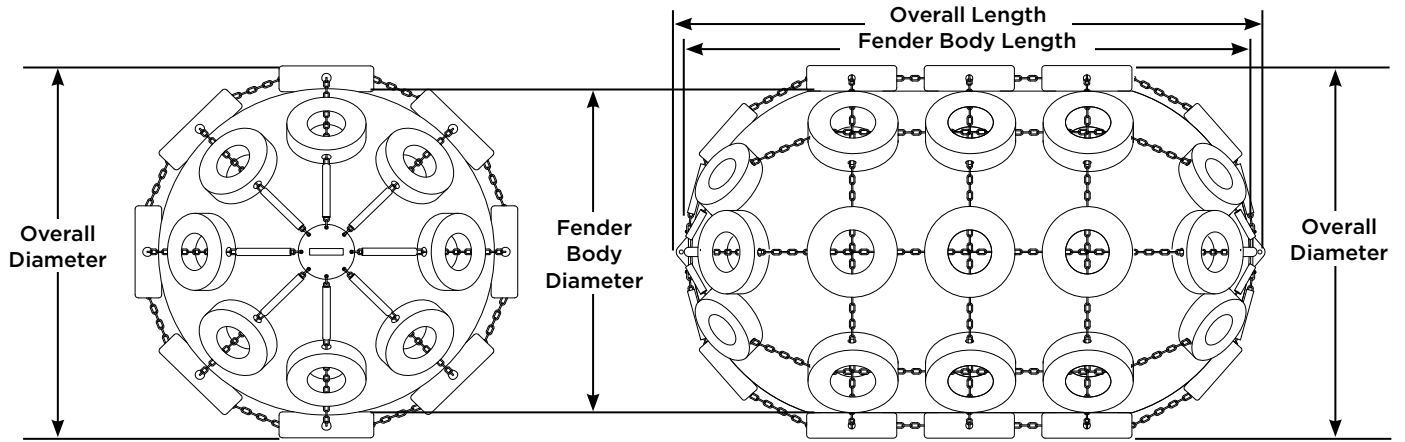

OCEAN GUARD™ SMALL STANDARD DUTY FOAM FILLED FENDER

Ocean Guard™ Small Standard Duty (SSD) & Ocean Guard™ Small Standard Duty with Hawse Pipe fitting (SSD-HP) foam filled marine fenders are designed for quick and convenient use. SSD fenders compact sizes are ideal for the limited storage space available on board of Naval and Commercial Vessels. Their light weight allows for easy installation and can be handled by one or two people.

OCEAN GUARD™ SMALL STANDARD DUTY (SSD)

SSD fenders are constructed in accordance with US Navy Technical Specifications. They are built with the same quality construction and materials as OCEAN GUARD™ fenders.

- Lightweight heat laminated closed cell resilient energy absorbing foam core
- Tough non-marking nylon Tire Cord reinforced urethane elastomeric skin
- Integral end fittings either stainless steel or galvanized
- Optional internal through chain

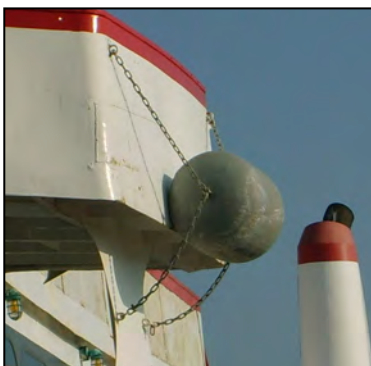
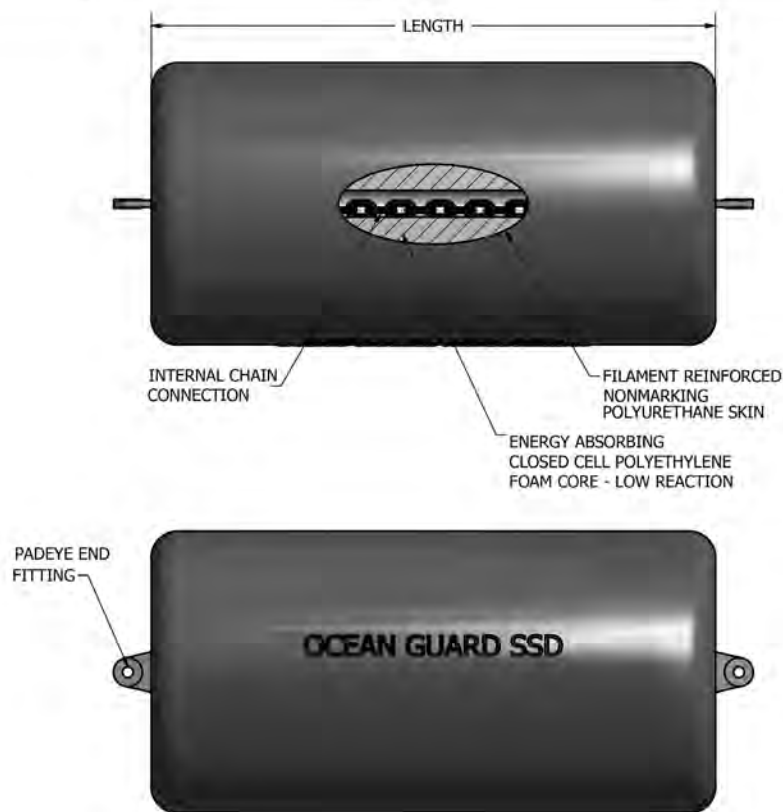

OCEAN GUARD™ SSD FOAM FILLED FENDERS

FENDERS SIZE		LOW REACTION				ENHANCED CAPACITY				STANDARD CAPACITY				HARDWARE	
ENGLISH	METRIC	ENERGY ABSORPTION		REACTION FORCE		ENERGY ABSORPTION		REACTION FORCE		ENERGY ABSORPTION		REACTION FORCE		SHACKLE SIZE	
		FT-KIPS	TON-M	KIPS	TONS	FT-KIPS	TON-M	KIPS	TONS	FT-KIPS	TON-M	KIPS	TONS	TONS	MM
16 x 24	400 x 600	1.7	0.2	10.8	4.9	2.2	0.3	14.4	6.5	2.8	0.4	18.0	8.2	0.5	13
16 x 36	400 x 900	3.2	0.4	12.0	5.4	4.2	0.6	16.0	7.3	5.3	0.7	20.0	9.1	0.5	13
18 x 36	457 x 900	4.1	0.6	12.4	5.6	5.4	0.8	16.6	7.5	6.8	0.9	20.7	9.4	0.5	13
20 x 36	500 x 900	4.9	0.7	13.6	6.2	6.6	0.9	18.1	8.2	8.2	1.1	22.6	10.3	0.5	13
20 x 39	500 x 1000	5.3	0.7	14.7	6.7	7.0	1.0	19.6	8.9	8.8	1.2	24.5	11.1	0.5	13
20 x 48	500 x 1200	6.6	0.9	18.0	8.2	8.8	1.2	24.0	10.9	11.0	1.5	30.0	13.6	0.5	13
22 x 48	558 x 1200	7.3	1.0	19.8	9.0	9.8	1.3	26.4	12.0	12.2	1.7	33.0	15.0	0.5	13
24 x 36	600 x 900	6.3	0.9	14.7	6.7	8.4	1.2	19.6	8.9	10.5	1.5	24.5	11.1	0.5	13
24 x 48	600 x 1200	8.4	1.2	19.2	8.7	11.2	1.5	25.6	11.6	14.0	1.9	32.0	14.5	0.5	13
32 x 50	800 x 1270	16.8	2.3	64.8	29.1	22.4	3.1	86.4	38.8	28.0	3.9	108.0	48.5	0.625	16
36 x 48	900 x 1200	20.4	2.8	31.2	14.2	27.2	3.8	41.6	18.9	34.0	4.7	52.0	23.6	0.625	16
36 x 60	900 x 1500	25.0	3.5	39.0	17.7	33.3	4.6	52.0	23.6	41.6	5.8	65.0	29.5	0.625	16
36 x 72	900 x 1828	32.0	4.4	50.0	22.7	42.6	5.9	66.6	30.2	53.3	7.4	83.3	37.8	0.625	16
39 x 60	1000 x 1500	30.0	4.1	42.0	19.1	40.0	5.5	56.0	25.4	50.0	6.9	70.0	31.8	0.625	16
40 x 60	1016 x 1500	31.2	4.3	43.7	19.8	41.6	5.8	58.2	26.4	52.0	7.2	72.8	33.0	0.625	16

OCEAN GUARD™ SMALL STANDARD DUTY WITH HAWSE PIPE (SSD-HP)

SSD-HP fenders are constructed equivalent to our OCEAN GUARD™ Small Standard Duty (SSD) foam filled fenders, which they exception that they are constructed with a heavy duty thru pipe - Hawse pipe instead of pad eye end fittings.

- Standard denser heat laminated closed cell resilient energy absorbing foam core
- Tough non-marking nylon Tire Cord reinforced urethane elastomeric skin
- Hawse pipe (thru pipe) construction



* Actual values for above sizes may vary +/- 15% due to variations in materials, speed of compression, temperatures and tolerances. Performance based on 60% compression.



A SERIES

THROUGHOUT THE WORLD, MORE PEOPLE RELY ON OUR A SERIES THAN ALL OTHER BUOYS.

The A Series is the product that launched the Polyform story. This all-purpose product, with the signature “blue ropehold,” has proven itself in the most adverse conditions. We’ve made a couple of changes to the legendary A-Series for 2001. There’s a new size – the A-7, with more buoyancy than any other buoy in its class, and a redesigned ropehold. The new ropehold has been incorporated into the A-5, A-6, and A-7 and features stronger ribs, a larger eye that accepts a standard shackle, and a new “dual valve” inflation-deflation system. Marking gear in heavy seas is no easy task. That’s why more fishermen use Polyform A Series than all other buoys combined. We’ve seen and heard the testimonials from our customers. You name the ocean, sea, or river, and the A Series has been there. Put your trust in Polyform’s most versatile and well-known product.

Model	Size (In) (Dia x Length)	Eye Dia. (in)	Circum. (in)	Volume (Gallons)	Pieces Per Carton
A-0	8 x 11.5	0.6	25.1	1.6	20
A-1	11 x 15	1	34.6	3.5	10
A-2	14.5 x 19.5	1.125	45.6	8.2	10
A-3	17 x 23	1.125	53.4	14.5	10
A-4	20.5 x 27	1.125	64.4	22.5	10
A-5	27 x 36	1.25	84.9	47.6	5
A-6	34 x 44	1.5	106.9	95.1	3
A-7	39 x 54	2	122.6	162	2

F SERIES

CLASSIC EUROPEAN TWIN-EYE STYLE FENDERS DESIGNED FOR THE MOST DEMANDING USE.

Polyform has been producing this fender for over 40 years and there is no comparison when it comes to quality, range of sizes and protection offered. The F Series fender has offered protection to the finest yachts and fishing vessels all over the world. Why?

Because the owners and the captains of these prestigious boats know that they can rely on Polyform’s F Series to offer the size, strength and dependability to protect their vessel from the rigors of the sea and weather. If you want the ultimate in protection for your boat, Polyform F Series is the only choice!

Model	Size (In) (Dia x Length)	Eye Dia. (in)	Circum. (in)	Volume (Gallons)	Pieces Per Carton
F-1	6 x 24	0.7	18.9	1.9	10
F-02	7.5 x 26	0.7	23.6	3.1	10
F-2	8.2 x 25	0.9	25.8	4.3	10
F-3	8.2 x 30	0.9	25.8	5.4	10
F-4	8.5 x 40.5	0.9	26.7	7.7	5
F-5	11 x 30	1	34.6	7.3	5
F-6	11 x 42	1	34.6	15.1	5
F-7	15 x 41	1	47.1	18.8	5
F-8	15 x 58	1	47.1	39.6	4
F-10	18 x 50	1	56.6	33.8	2
F-11	21.2 x 57.5	1.1	66.6	63.7	3
F-13	29 x 76.5	1.2	91.1	158.6	2

RUBBER FENDERS

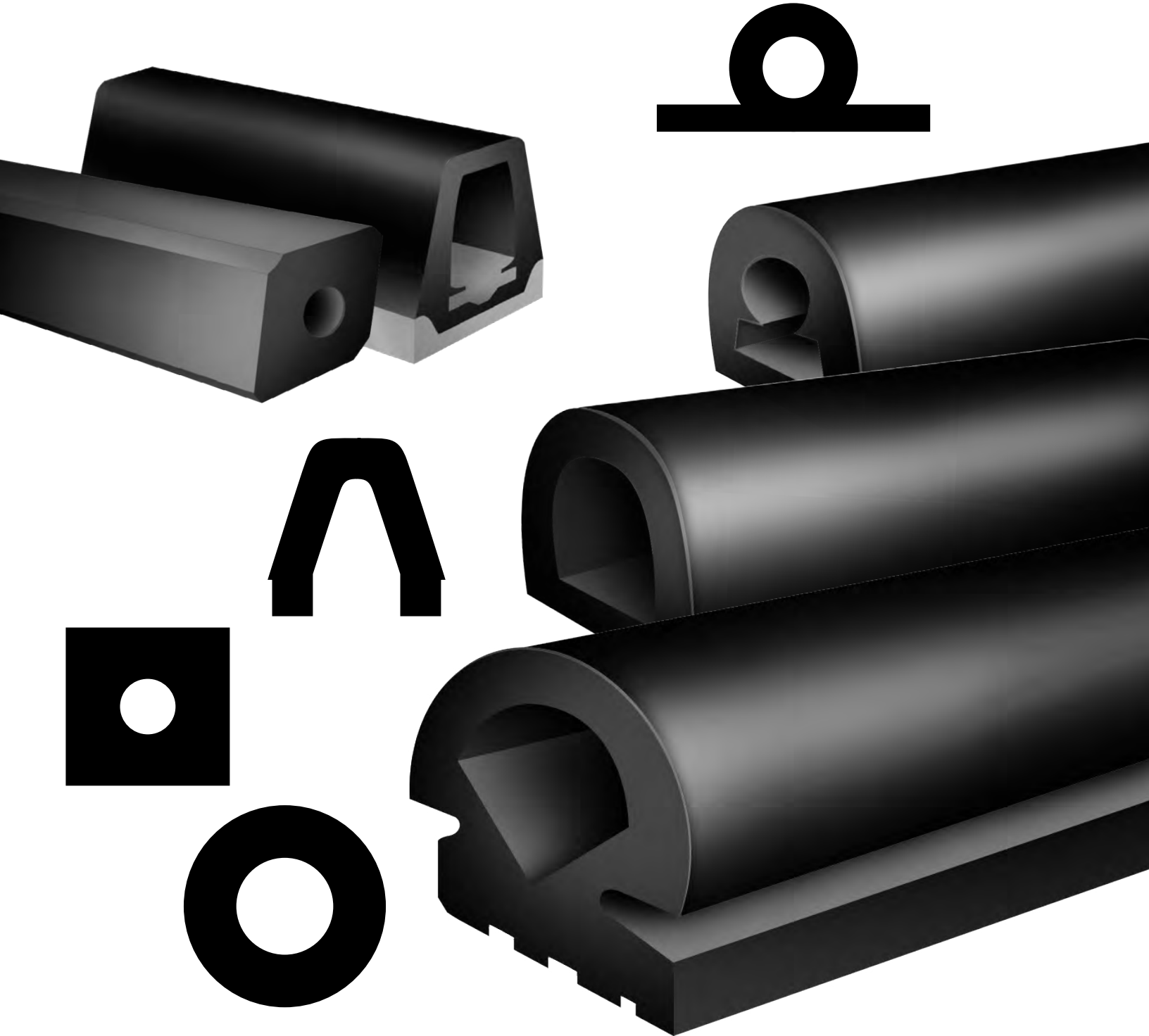

TYPES, SIZES & WEIGHTS CYLINDRICAL FENDERS

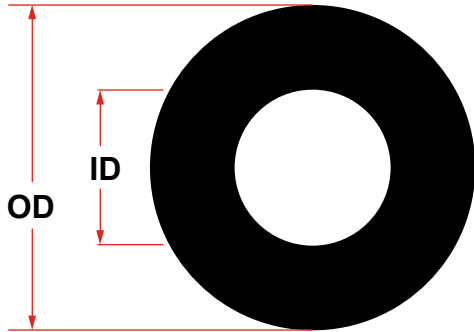

Tolerances:
+/- 3% on faces
+/- 8% on bore
+/- 1% on length
or 1/2"

RECTANGULAR FENDERS

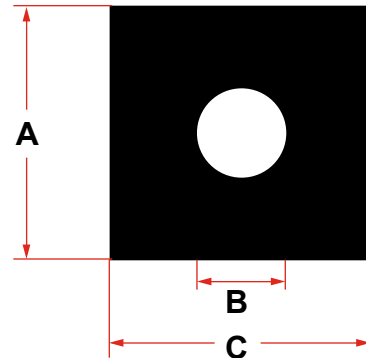

Tolerances:
+/- 4% on faces
+/- 8% on bore
+/- 1% on length
or 1/2"

D-Bore Optional.

DIMENSIONS (INCHES)

OD	ID	WT*
7	3-1/2	14
7	3	16
8	4	19
8	3-1/2	21
10	5	30
12	6	43
15	7-1/2	67
18	9	97
21	10-1/2	131
24	12	171
28	14	233
32	16	294
36	18	372
48	24	661
60	30	1032

* LBS./FT.

DIMENSIONS (MM)

OD	ID	WT*
178	89	21
178	75	24
203	102	28
203	89	31
254	127	45
305	152	64
381	191	100
457	229	144
533	267	195
610	305	255
711	356	347
813	406	437
914	457	554
1219	610	984
1524	762	1535

* KG/METER

DIMENSIONS (INCHES)

A	B	C	WT*
4	0	8	16.0
5	2-1/2	6	13.0
5	2-1/2	6-1/2	14.0
6	2-1/2	6-1/2	19.5
6	3	10	27.0
6	2	12	35.0
7	3	10	32.0
8	3	8	29.0
8	3	10	37.0
10	4	10	44.5
10	4	12	54.0
12	5	12	63.0
12	6	14	71.0
14	6	14	85.0
16	6-1/2	16	114.0
18	7-1/4	18	143.0
20	8	20	177.0

* LBS./FT.

DIMENSIONS (MM)

A	B	C	WT*
102	0	203	23.8
127	64	152	19.3
127	64	165	20.8
152	64	165	29.0
152	76	254	40.2
152	51	305	52.0
178	76	254	47.6
203	76	203	43.2
203	76	254	55.1
254	102	254	66.2
254	102	305	80.4
305	127	305	93.7
305	152	356	105.7
356	152	356	126.5
406	165	406	169.4
457	184	457	212.4
508	203	508	263.0

* KG/METER

WING-TYPE FENDERS

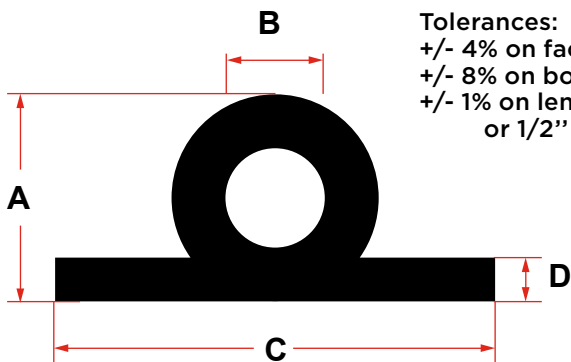

Tolerances:
+/- 4% on faces
+/- 8% on bore
+/- 1% on length
or 1/2"

DIMENSIONS (INCHES) WEIGHTS (LBS./FT)

A	B	C	D	WT
6	3	9	1-1/2	15.4
8	4	12	2	26.0
10	4	16	2-1/2	46.0
12	6	18	3	59.0

DIMENSIONS (MM) WEIGHTS (KG./METER)

A	B	C	D	WT
152	76	229	38	22.9
203	101	305	51	38.7
254	101	406	64	68.4
305	152	457	76	87.8

ROUND BORE

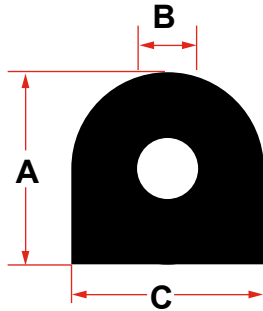

Tolerances:
+/- 4% on faces
+/- 8% on bore
+/- 1% on length
or 1/2"

DIMENSIONS (INCHES) WEIGHTS (LBS./FT)

A	B	C	WT
6	2-1/2	5	11.5
8	3	8	25.5
10	3	8	34.5
10	4	10	39.0
10	4	12	46.0
12	5	12	55.0
14	6	14	75.0
14	3	18	104.0

DIMENSIONS (MM) WEIGHTS (KG/METER)

A	B	C	WT
152	64	127	17.1
203	76	203	37.9
254	76	203	51.3
254	102	254	58.0
254	102	305	68.4
305	127	305	81.8
356	152	356	112.0
356	76	457	155.0

D-SHAPED BORE

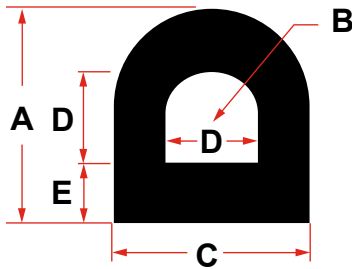

Tolerances:
+/- 4% on faces
+/- 8% on bore
+/- 1% on length
or 1/2"

DIMENSIONS (INCHES) WEIGHTS (LBS./FT)

A	B	C	D	E	WT
6	3	6	3	1-1/2	12.5
8	4	8	4	2	22.0
10	5	10	5	2-1/2	34.0
12	6	12	6	3	49.0
14	7	14	7	3-1/2	66.0
16	8	16	8	4	86.0
18	9	18	9	4-1/2	109.0
20	10	20	10	5	135.0

DIMENSIONS (MM) WEIGHTS (KG/METER)

A	B	C	D	E	WT
152	76	152	79	38	18.6
203	101	203	101	51	32.7
254	127	254	127	64	506.0
305	152	305	152	76	72.9
356	178	356	178	89	98.2
406	203	406	203	102	128.0
457	229	457	229	114	162.2
508	254	508	254	127	200.9

"D" FENDERS TAPERED SIDES

DIMENSIONS (INCHES) WEIGHTS (LBS./FT)

A	B	C	D	E	WT
3-3/4	2	4-1/2	2-1/4	3/4	5.0
6	2-7/8	6-3/4	3	1-1/2	12.5

A	B	C	D	E	WT
95	51	114	57	19	7.4
152	73	171	76	38	18.6

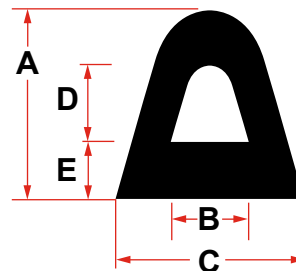

Tolerances:
+/- 4% on faces
+/- 8% on bore
+/- 1% on length
or 1/2"

DELTA "A" SERIES, EXTERNAL PLATE

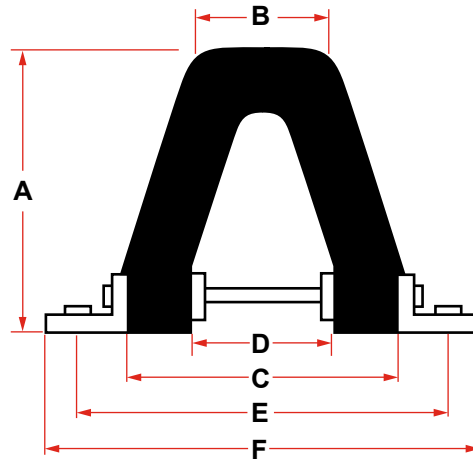

Tolerances:
 +/- 4% on faces
 +/- 8% on bore
 +/- 1% on length
 or 1/2"

DIMENSIONS (INCHES) WEIGHTS IN LBS./FT.

MODEL	A	B	C	D	E	F
13A	12	7-1/2	13	6-1/2	17	20
20A	16	10	20	10	25	28
23A	20	12	23	12	29	33

* RUBBER/STEEL

MODEL	A	B	C	D	E	F
13A	305	191	330	165	432	508
20A	406	254	508	254	635	711
23A	508	305	584	305	737	838

* RUBBER/STEEL

Rubber options: EPDM/butyl, butyl, low-friction butyl and non-marking gray EPDM rubber compounds all are available.

Designer's note: Consult Waterman Supply for design/budgetary assistance on any special shape or profile. Our analysis can include load deflection/energy characteristics, as well as low/high temperature behavior, shape factor limitations, tear strength and other design criteria free of charge. Special compounds may be recommended for specific problem solutions.

COMMERCIAL BUMPERS

100 SERIES - "D" SHAPE

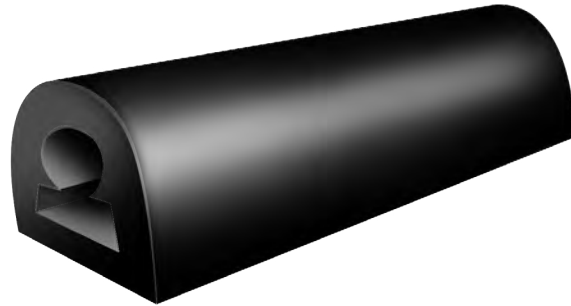
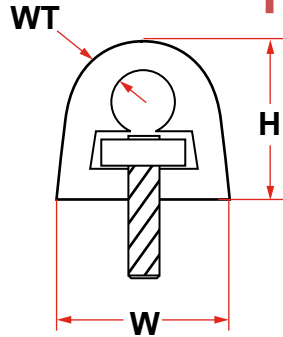

CODE NO.	COLOR	DIMENSIONS (INCHES)			WT./FT. LBS.	LENGTH UP TO
		BASE WIDTH (W)	HEIGHT (H)	WALL THKNS. (WT)		
DB-50	Black	2-1/8	2	7/16	1.3	60 FT.
DB-50B	Grey	2-1/8	2	7/16	1.6	60 FT.
DB-50C	White	2-1/8	2	7/16	1.6	60 FT.
DB-75	Black	3-1/8	2-7/8	11/16	2.8	60 FT.
DB-75B	Grey	3-1/8	2-7/8	11/16	3.4	60 FT.
DB-75C	White	3-1/8	3-7/8	11/16	3.4	60 FT.
DB-100	Black	4-1/4	3-7/8	3/4	4.6	60 FT.
DB-100B	Grey	4-1/4	3-7/8	3/4	5.3	60 FT.
DB-100C	White	4-1/4	3-7/8	3/4	5.3	60 FT.

D SHAPE / D-BORE

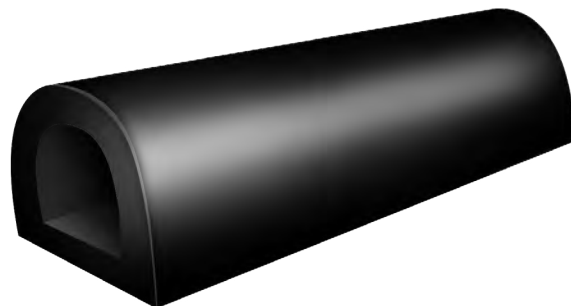
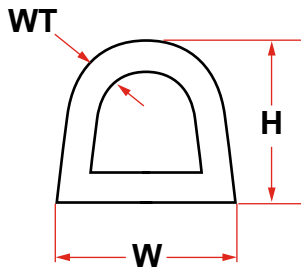

CODE NO.	COLOR	DIMENSIONS (INCHES)			WT./FT. LBS.	LENGTH UP TO
		BASE WIDTH (W)	HEIGHT (H)	WALL THKNS. (WT)		
DB-101	Black	4-1/4	3-7/8	3/4	4.6	60 FT.
DB-115	Black	4-1/2	3-3/4	3/4	4.7	60 FT.
DB-125	Black	6-3/4	6	1-1/2	13.6	20 FT.
DB-150	Black	9-1/2	8	1-1/2	19.5	20 FT.

200 SERIES - CYLINDRICAL FENDER

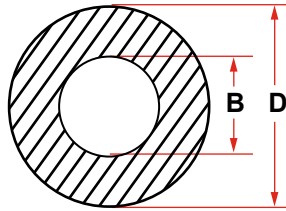

CODE NO.	DIMENSIONS (INCHES)		WT./FT. LBS.	LENGTH UP TO
	OUTSIDE DIAMETER (D)	BORE (B)		
DB-202	3	1	3.2	60 FT.
DB-203	3	1-1/2	2.7	60 FT.
DB-205	5	2-1/2	8.0	30 FT.
DB-206	7	3	16.0	20 FT.
DB-207	7	3-1/2	15.5	20 FT.
DB-208	8	4	18.2	20 FT.
DB-210	10	5	32	20 FT.
DB-212	12	6	46	20 FT.
DB-215	15	7-1/2	67	20 FT.
DB-218	18	9	96.7	10 FT.

300 SERIES - RECTANGULAR FENDER

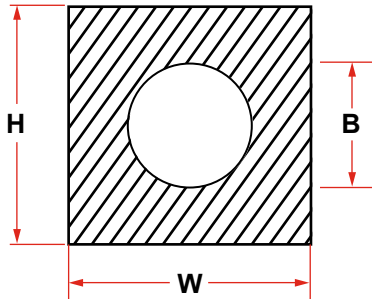

CODE NO.	DIMENSIONS (INCHES)			WT./FT. LBS.	LENGTH UP TO
	HEIGHT (H)	WIDTH (W)	BORE (B)		
DB-302	2	4	SOLID	3.9	60 FT.
DB-303	3-1/2	4-1/2	1	8.0	60 FT.
DB-304	5	5	2-1/2	9.8	60 FT.
DB-305	5	6-1/2	2-1/2	13.0	40 FT.
DB-305A	5-1/2	6	2-1/2	13.9	40 FT.
DB-306	6	6-1/2	2-1/2	17.4	20 FT.
DB-306A	6	6	2-7/8	14.6	20 FT.
DB-306B	6	7	2-1/2	18.0	20 FT.
DB-307	7	10	3	34.1	20 FT.
DB-307A	7	10	3-1/2	30.0	20 FT.
DB-308	8	8	3	28.2	20 FT.
DB-309	8	10	3	39.5	20 FT.
DB-309A	9	10	SOLID	50.7	20 FT.
DB-310	10	10	4	42.4	20 FT.
DB-311	10	12	4	60.0	20 FT.
DB-312	12	12	5	68.0	20 FT.
DB-313	12	12	4	68.5	20 FT.
DB-314	14	14	6	83	20 FT.

400 SERIES

WING TYPE "O" BORE

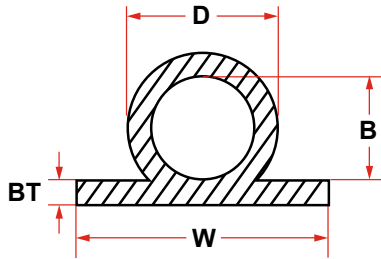

CODE NO.	DIMENSIONS (INCHES)				WT./FT. LBS.	LENGTH UP TO
	BASE WIDTH (W)	BASE THICKNESS (BT)	OUTSIDE DIAMETER (D)	BORE (B)		
DB-404	4	1/2	2-1/2	1	3.5	60 FT.
DB-405	5	1/2	2-1/2	1	4.0	60 FT.
DB-406	6	3/4	3	1	5.3	60 FT.
DB-407	6-1/2	1	4	2	7.0	60 FT.
DB-408	6-1/2	1	4	1	8.9	60 FT.
DB-409	9	1-1/2	6	3	14.4	20 FT.
DB-410	9-1/2	1-1/2	6	2	16.2	20 FT.
DB-412	12	2	8	4	27.0	20 FT.
DB-416	16	2-1/2	10	4	46.0	20 FT.
DB-418	18	3	12	6	61.0	20 FT.

WING TYPE SOLID BORE

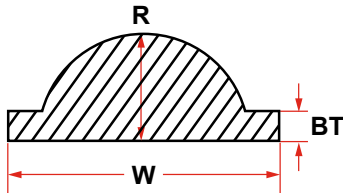

CODE NO.	DIMENSIONS (INCHES)			WT./FT. LBS.	LENGTH UP TO
	BASE WIDTH (W)	BASE THICKNESS (BT)	RADIUS (R)		
DB-460	10	1-1/4	4	14.6	20 FT.

WING TYPE "D" BORE

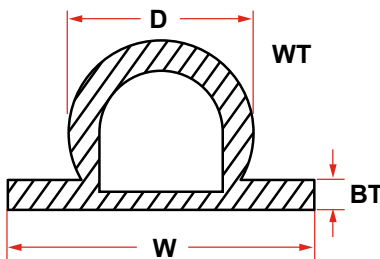

CODE NO.	DIMENSIONS (INCHES)				WT./FT. LBS.	LENGTH UP TO
	BASE WIDTH (W)	BASE THICKNESS (BT)	OUTSIDE DIAMETER (D)	WALL THICKNESS (WT)		
DB-440	9-1/2	1-1/2	6	1	14.9	20 FT.

500 SERIES - FAN NOSE

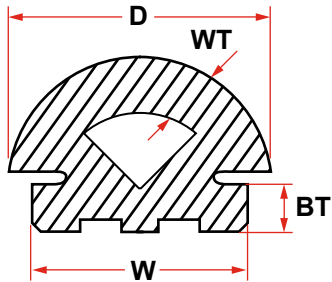

CODE NO.	DIMENSIONS (INCHES)				WT./FT. LBS.	WALL THICK.	LENGTH UP TO
	BASE WIDTH (W)	BASE THICKNESS (BT)	OUTSIDE DIAMETER (D)	P			
DB-503*	2-1/2	17/32	3	1/4	2.5	5/8	60 FT.
DB-504*	3-3/4	25/32	4-1/4	1/4	3.2	3/4	60 FT.
DB-506*	5-7/16	1	6	5/16	9.0	1	40 FT.
DB-508*	7-1/4	1-3/16	8	3/8	15.5	1-1/2	20 FT.
DB-510*	9-1/4	1-11/16	10	3/8	24.8	1-1/2	20 FT.
DB-512*	11	2	12	9/16	28.6	2	20 FT.

* WHITE OR GREY UPON REQUEST

800 SERIES - CORNER GUARD

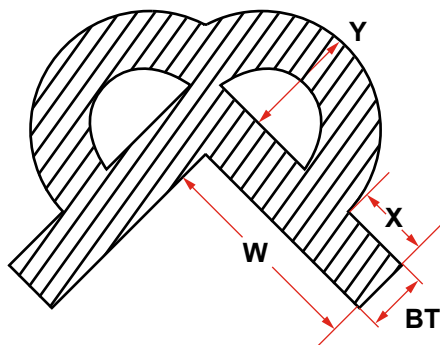

CODE NO.	DIMENSIONS (INCHES)				WT./FT. LBS.	LENGTH UP TO
	BASE WIDTH (W)	BASE THICKNESS (BT)	WING LENGTH (X)	OUTSIDE DIAMETER (Y)		
DB-809*	5-9/16	1-1/2	2	3	21.0	10 FT.

* WHITE OR GREY UPON REQUEST

900 SERIES - D-SHAPED / O-BORE



CODE NO.	DURAMAX PART NO.	BASE WIDTH (W)	BASE HEIGHT (H)	BORE (B)	WT./FT.	LENGTH UP TO
DB-906	802090601	5"	6"	2-1/2"	11.7 LBS.	20 FT.
DB-906A	802090611	6"	6"	3"	13 LBS.	20 FT.
DB-908	802090801	8"	8"	3"	26.2 LBS.	20 FT.
DB-909	802090901	8"	10"	3"	34 LBS.	20 FT.
DB-909B	802090911	9-1/4"	10"	3"	40 LBS.	20 FT.
DB-910	802091001	10"	10"	3"	43 LBS.	20 FT.
DB-910A	802091011	10"	10"	4"	41.7 LBS.	20 FT.
DB-912	802091201	12"	12"	4"	66 LBS.	20 FT.
DB-912A	802091211	12"	12"	5"	65 LBS.	20 FT.
DB-912B	802090013	12"	14"	5"	69.6 LBS.	20 FT.
DB-912C	802091231	12"	14"	4"	73.3 LBS.	20 FT.
DB-914	802091401	14"	14"	6"	76.8 LBS.	20 FT.
DB-914B	802091421	14"	12"	6"	60 LBS.	20 FT.
DB-914C	802091431	13.5"	12"	6"	60 LBS.	20 FT.

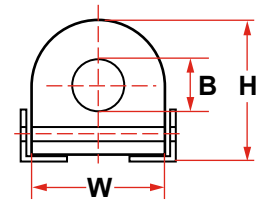

900 SERIES - D-SHAPED / D-BORE



CODE NO.	DURAMAX PART NO.	BASE WIDTH (W)	BASE HEIGHT (H)	BORE (B)	WT./FT.	LENGTH UP TO
DB-954	802090022	4"	4"	2" x 2"	6 LBS.	20 FT.
DB-956	802090021	6"	6"	3" x 3"	12.5 LBS.	20 FT.
DB-958	802090005	8"	8"	4" x 4"	22.5 LBS.	20 FT.
DB-960	802090011	10"	10"	5" x 5"	35.1 LBS.	20 FT.
DB-962	802090015	12"	12"	6" x 6"	50.5 LBS.	20 FT.
DB-964	802090003	14"	14"	7" x 7"	72 LBS.	20 FT.

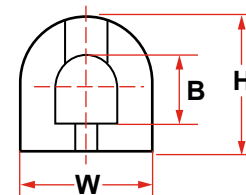

1000 SERIES - FLAT HEAD

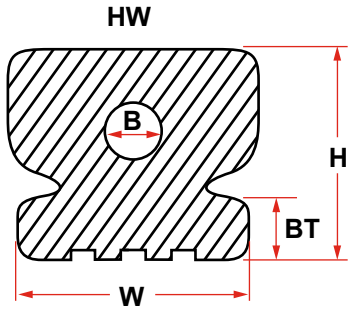

CODE NO.	BASE WIDTH (W)	BASE THKNS. (BT)	HEAD WIDTH (HW)	HEIGHT	BORE (B)	WT./FT.	LENGTHS UP TO
DB-1006	6-1/2"	1-11/16"	7-3/8"	6"	1-3/4"	18.6 LBS.	30 FT.
DB-1009	9"	2-29/32"	9-7/16"	7-1/2"	3"	24 LBS.	30 FT.

1000 SERIES - CHANNEL LOCK

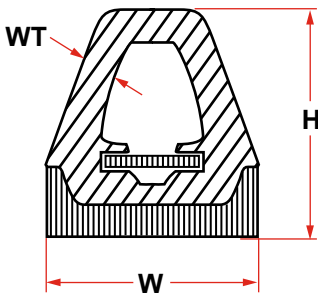

CODE NO.	BASE WIDTH (W)	HEIGHT (H)	WALL THKNS. (WT)	WT./FT. RUBBER ONLY	LENGTHS UP TO	NOT SUPPLIED AS STANDARD EQUIPMENT
DB-1103	3"	3-1/4"	1-9/32"	2.8 LBS.	60 FT.	REYNOLDS ALUMINUM CHANNEL NO. 351 3" X .247 WEB 1/4" X 1-1/2" ALUM. BAR
DB-1104	4"	4-5/16"	3/4"	4.5 LBS.	40 FT	REYNOLDS ALUMINUM CHANNEL NO. 2644 4" X .247 WEB 1/4" X 2" ALUM. BAR

ANCHOR PATTERN SHACKLES

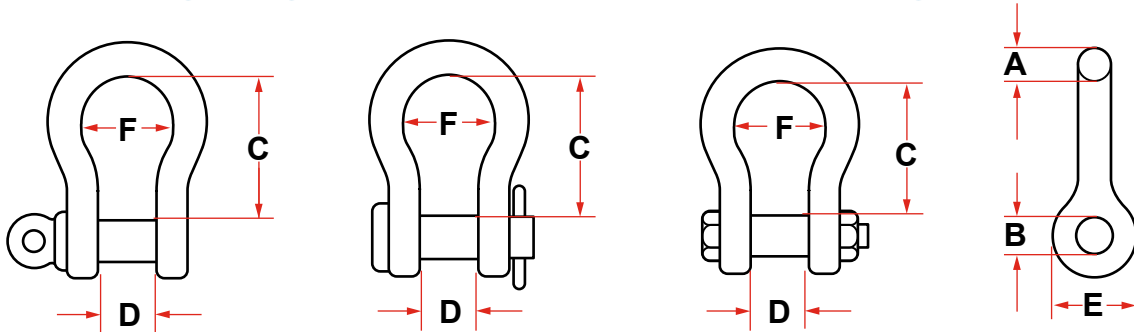

HEAT-TREATED, DROP FORGED CARBON STEEL
ANCHOR SHACKLE: SCREW PIN, ROUND PIN, SAFETY BOLT PIN

RATED LOAD TONS	DIMENSIONS (INCHES)						WEIGHT IN POUNDS	
	A	B	C	D	E	F	SCREW PIN OR ROUND PIN	SAFETY BOLT
0.33	3/16	1/4	7/8	3/8	9/16	19/32	0.05	
0.5	1/4	5/16	1-1/8	1/2	3/4	3/4	0.12	
0.75	5/16	3/8	1-1/4	9/16	7/8	1	0.18	
1	3/8	7/16	1-7/16	11/16	1	1-1/8	0.3	
1.5	7/16	1/2	1-11/16	3/4	1-1/8	1-1/4	0.5	
2	1/2	5/8	1-7/8	13/16	1-3/16	1-5/16	0.75	0.8
3.25	5/8	3/4	2-7/16	1-1/16	1-9/16	1-11/16	1.5	1.6
4.75	3/4	7/8	3	1-1/4	1-7/8	2	2.16	3.0
6.5	7/8	1	3-5/16	1-7/16	2-1/8	2-1/4	3.37	4.0
8.5	1	1-1/8	3-3/4	1-11/16	2-3/8	2-5/8	5.3	5.5
9.5	1-1/8	1-1/4	4-1/4	1-7/8	2-5/8	3	7.0	8.0
12	1-1/4	1-3/8	4-1/2	2	2-15/16	3-3/8	9.6	11.0
13.5	1-3/8	1-1/2	5-1/4	2-1/4	3-5/16	3-5/8	12.6	15.0
17	1-1/2	1-5/8	5-3/4	2-3/8	3-5/8	3-7/8	17.3	19.5
21	1-5/8	1-3/4	6-1/4	2-5/8	3-3/16	4-3/8	21.0	23.0
25	1-3/4	2	7	2-7/8	4-5/16	5	27.8	31.5
35	2	2-1/4	7-3/4	3-1/4	5	5-3/4	41.0	42.0
42	2-1/4	2-1/2	8-3/4	3-7/8	5-1/2	6-1/2	65.0	69.0
55	2-1/2	2-3/4	10	4-1/8	6	7-1/4	83.5	94.0
60	2-3/4	3	11-1/4	4-1/2	6-1/4	8	118.0	121.0
85	3	3-1/4	13	5	6-3/4	9	140.0	146.0
120	3-1/2	3-3/4	15	5-3/4	8-1/2	10-1/8		250.0
150	4	4-1/4	17	6-1/2	9-3/8	10-1/2		360.0
175	4-1/2	4-3/4	19	7-1/4	10	12-1/2		445.0

Sizes 3/16" Thru 1" Available in Stainless Steel Safety Type
NOTES: Minimum breaking strength is six times rated working load.
Furnished in galvanized or self colored finish.

Pins are galvanized after threading.
Shackles can be furnished with complete traceability, proof test certificates, and serial number at slight additional charge.

CHAIN PATTERN SHACKLES

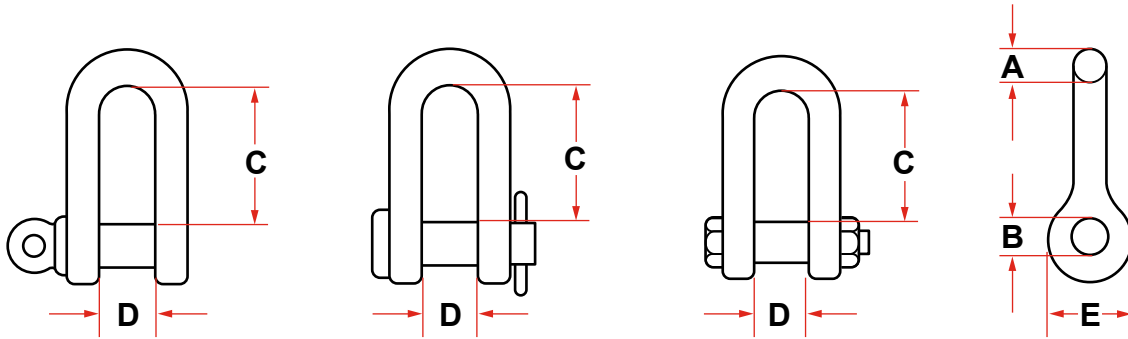

**HEAT-TREATED, DROP FORGED CARBON STEEL
CHAIN SHACKLE: SCREW PIN, ROUND PIN, SAFETY BOLT PIN**

RATED LOAD TONS	DIMENSIONS (INCHES)					WEIGHT IN POUNDS	
	A	B	C	D	E	SCREW PIN OR ROUND PIN	SAFETY BOLT
0.33	3/16	1/4	7/8	3/8	9/16	0.05	
0.5	1/4	5/16	1-1/8	1/2	3/4	0.1	
0.75	5/16	3/8	1-1/4	9/16	7/8	0.18	
1	3/8	7/16	1-7/16	11/16	1	0.25	
1.5	7/16	1/2	1-11/16	3/4	1-1/8	0.41	
2	1/2	5/8	1-7/8	13/16	1-3/16	0.61	0.8
3.25	5/8	3/4	2-7/16	1-1/16	1-9/16	1.2	1.4
4.75	3/4	7/8	3	1-1/4	1-7/8	2.12	2.5
6.5	7/8	1	3-5/16	1-7/16	2-1/8	3.28	3.8
8.5	1	1-1/8	3-3/4	1-11/16	2-3/8	4.6	5.5
9.5	1-1/8	1-1/4	4-1/4	1-7/8	2-5/8	6.3	7.5
12	1-1/4	1-3/8	4-1/2	2	2-15/16	9.25	10.8
13.5	1-3/8	1-1/2	5-1/4	2-1/4	3-5/16	12.19	14.3
17	1-1/2	1-5/8	5-3/4	2-3/8	3-5/8	16.15	19.0
21	1-5/8	1-3/4	6-1/4	2-5/8	3-13/16	21.0	23.0
25	1-3/4	2	7	2-7/8	4-5/16	27.0	30.5
35	2	2-1/4	7-3/4	3-1/4	5	39.5	45.0
42	2-1/4	2-1/2	8-3/4	3-7/8	5-1/2	65.0	69.0
55	2-1/2	2-3/4	10	4-1/8	6	72.0	82.0
60	2-3/4	3	11-1/4	4-1/2	6-1/4		98.0
85	3	3-1/4	13	5	6-3/4		135.0
120	3-1/2	3-3/4	15	5-3/4	8-1/2		187.0
150	4	4-1/4	17	6-1/2	9-3/8		360.0
175	4-1/2	4-3/4	19	7-1/4	10		445.0

Sizes 3/16" Thru 1" Available in Stainless Steel Safety Type
NOTES: Minimum breaking strength is six times rated working load.
Furnished in galvanized or self colored finish.

Pins are galvanized after threading.
Shackles can be furnished with complete traceability, proof test certificates,
and serial number at slight additional charge.

GREEN PIN SUPER[®] BOW SHACKLE BN

GRADE 8 BOW SHACKLE WITH SAFETY BOLT

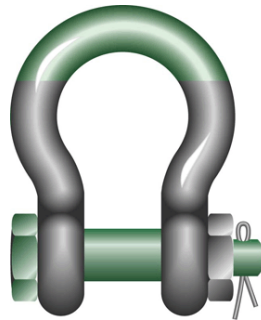

G-5263

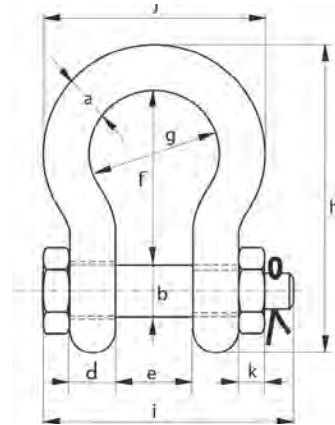

- **Material:** bow and pin alloy steel, grade 8, quenched and tempered MBL
- **Safety Factor:** equals 5 x WLL
- **Standard:** ASME B30.26 and meets performance requirements of US Fed. Spec. RR-C-271 Type IVA Class 3, grade B
hot dipped galvanized (150 t and upward are painted)
-20°C up to +200°C
- **Finish:** hot dipped galvanized (150 t and upward are painted)
- **Temperature Range:** -20°C up to +200°C
- **Certification:** [2.1](#) [2.2](#) [3.1](#) [MTC](#) [LROS](#) [CE IIA](#) [ABS PDA](#) [ABS MA](#)

Working Load Limit	Diameter Bow	Diameter Pin	Diameter Eye	Width Eye	Width Inside	Length Inside	Width Bow	Length	Length Bolt	Width	Thickness Nut	Weight Each
t mm	a mm	b mm	c mm	d mm	e mm	f mm	g mm	h mm	i mm	j mm	k mm	kg
3.3	13.5	16	34	13	22	51	32	90	80	59	13	0.40
5	16	19	40	16	27	64	43	110	98	75	17	0.73
7	19	22	46	19	31	76	51	129	115	89	19	1.19
9.5	22	25	52	22	36	83	58	144	130	102	22	1.73
12.5	25	28	59	25	43	95	68	164	150	118	25	2.56
15	28	32	67	28	47	108	75	186	166	131	27	3.60
18	32	35	73	32	51	115	83	201	184	147	30	4.95
21	35	38	79	35	57	133	92	227	197	162	33	6.62
30	38	42	88	38	60	146	99	249	202	175	33	8.11
40	45	50	104	45	74	178	126	300	243	216	23	14.8
55	57	57	119	57	83	197	138	342	283	252	26	24.2
85	70	70	145	70	105	260	180	438	339	320	32	45.1
120	83	83	164	83	127	329	190	537	397	356	39	72
150*	95	95	204	95	147	400	238	644	453	428	50	112
175*	105	108	235	105	169	410	275	686	496	485	50	160

* For shackles WLL 150 t and WLL 175 t available with and without LROS

* With round headed bolt

* Excluded from ABS Type Approval

TURNBUCKLES

ACCORDING TO FEDERAL SPECIFICATION FF-T-79LB

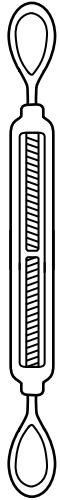

EYE & EYE

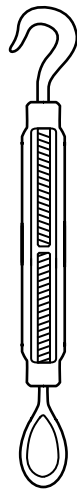

HOOK & EYE

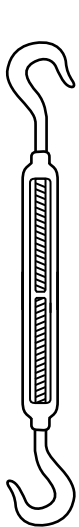

HOOK & EYE

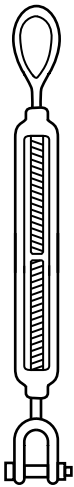

JAW & EYE

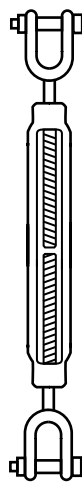

JAW & JAW

DIAMETER (A) AND TAKEUP (B) INCHES	AVERAGE OVERALL LENGTH (C) IN CLOSED POSITION INCHES	WEIGHT POUNDS EACH		
		WITH EVE OR HOOKS	JAW AND EYE	JAW AND JAW
1/4 x 4	8-1/4	0.31	0.33	0.35
5/16 x 4-1/2	9-9/16	0.50	0.53	0.58
3/8 x 6	11-7/8	0.79	0.86	0.93
1/2 x 6	13-5/16	1.42	1.54	1.66
9	16-5/16	1.83	1.95	2.07
12	19-5/16	2.01	2.19	2.37
5/8 x 6	15-1/2	2.61	2.81	3.02
9	18-1/2	2.81	3.01	3.22
12	21-1/2	3.12	3.32	3.53
18	28-1/8	6.00	6.20	6.40
3/4 x 6	17-1/16	3.60	3.87	4.18
9	20-1/8	4.69	4.98	5.27
12	23-1/16	5.07	5.36	5.65
18	29-1/16	6.21	6.51	6.81
7/8 x 12	24-5/8	8.10	8.75	9.40
18	30-5/8	9.93	10.60	11.20
1 x 6	20-5/8	8.75	9.15	9.50
12	26-5/8	10.40	11.20	12.10
18	32-5/8	13.20	14.10	14.90
24	38-5/8	15.90	16.80	17.60
1-1/4 x 12	29-7/8	19.00	20.50	22.00
18	35-7/8	23.40	24.90	26.40
24	41-7/8	27.80	29.30	30.90
1-1/2 x 12	32-3/8	26.10	28.20	30.30
18	38-3/8	37.50	39.60	41.80
24	44-3/8	43.10	45.20	47.30
36	58-3/4	52.60	54.80	57.00
1-3/4 x 18	41-3/4	45.00	48.80	52.40
24	47-3/4	52.20	56.00	59.60
2 x 24	51-3/4	89.80	94.60	100.00
2-1/2 x 24	58-1/2	140.00	150.00	161.00
2-3/4 x 24	61-1/2	194.00	200.00	216.00

When Ordering Be Sure to Specify:
 1st - Diameter of thread.
 2nd - Length of take-up.
 3rd - Self colored or galvanized.
 4th - The type of end fittings desired.

Larger sizes available per request.
 Lock nuts available per request.
 Jaw end fittings sizes 1/4" through 5/8" have bolts and nuts.
 Jaw end fittings sizes 3/4" through 2-3/4" have pins and cotters.
 Large jaw sizes available with bolts and nuts upon special request.

TURNBUCKLES

HOOK

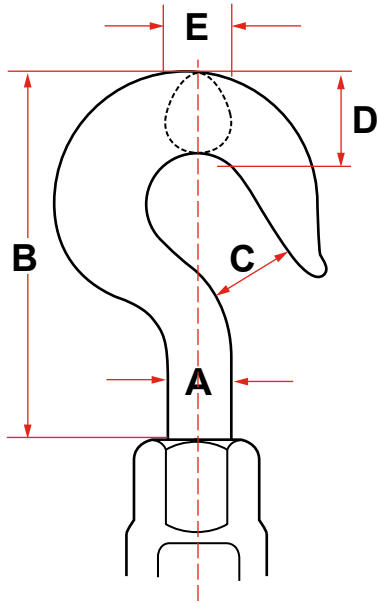

DIMENSIONS (INCHES)					RATED LOAD (LBS.)
A	B	C	D	E	
1/4	1-5/8	7/16	3/8	1/4	400
5/16	1-29/32	1/2	7/16	5/16	700
3/8	2-9/32	9/16	17/32	3/8	1000
1/2	2-27/32	21/32	11/16	1/2	1500
5/8	3-17/32	27/32	27/32	5/8	2250
3/4	4-5/16	31/32	1	3/4	3000
7/8	5	1-1/8	1-3/16	7/8	4000
1	5-11/16	1-1/4	1-3/8	1	5000
1-1/4	6-29/32	1-1/2	1-1/2	1-1/16	6500
1-1/2	8-11/16	1-7/8	1-3/4	1-5/16	7500

EYE

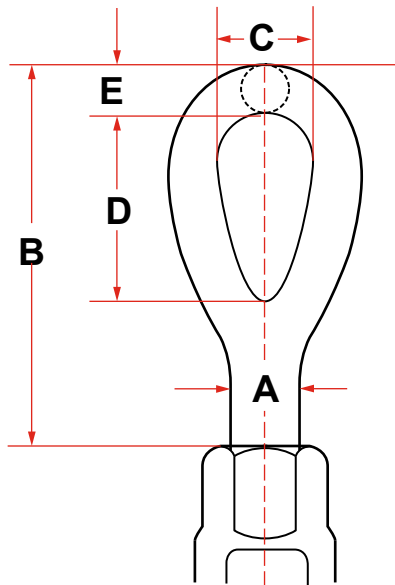

DIMENSIONS (INCHES)					RATED LOAD (LBS.)
A	B	C	D	E	
1/4	1-25/32	11/32	25/32	7/32	500
5/16	2-3/16	7/16	15/16	9/32	800
3/8	2-9/16	17/32	1-1/8	11/32	1200
1/2	3-7/32	23/32	1-7/16	7/16	2200
5/8	3-7/8	7/8	1-3/4	1/2	3500
3/4	4-11/16	1	2-1/8	5/8	5200
7/8	5-1/4	1-1/4	2-3/8	3/4	7200
1	6-3/8	1-7/16	3	7/8	10000
1-1/4	7-3/4	1-13/16	3-9/16	1-1/8	15200
1-1/2	8-5/8	2-1/8	4-1/8	1-1/4	21400
1-3/4	10	2-3/8	4-11/16	1-1/2	28000
2	12-1/8	2-11/16	5-3/4	1-3/4	37000
2-1/2	13-9/16	3-1/8	6-1/2	2	60000
2-3/4	15	3-1/4	7	2-1/4	75000

JAW

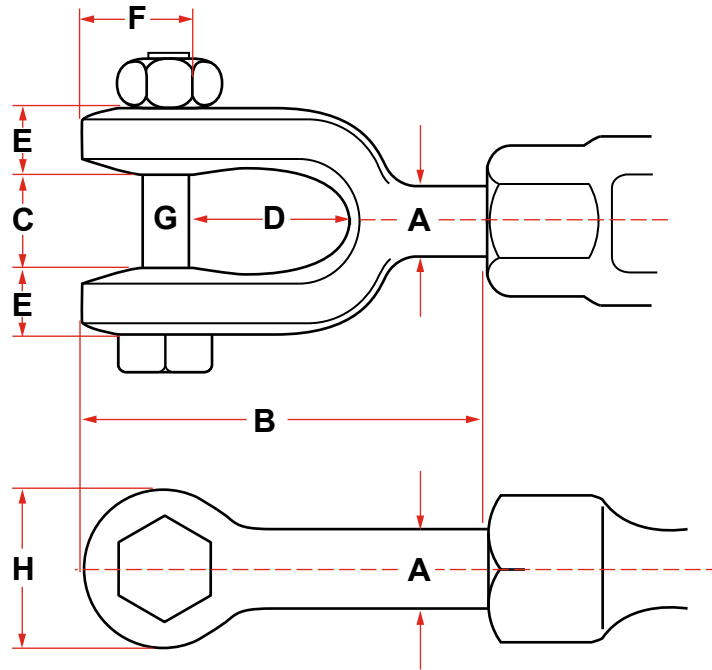

DIMENSIONS (INCHES)								RATED LOAD (LBS.)
A	B	C	D	E	F	G	H	
1/4	1-5/8	13/32	5/8	9/32	1/2	1/4	5/8	500
5-16	2	15/32	7/8	9/32	1/2	1/4	11/16	800
3/8	2-3/16	1/2	7/8	5/16	19/32	5/16	13/16	1200
1/2	2-3/4	5/8	1-1/16	13/32	3/4	3/8	1	2200
5/8	3-1/2	3/4	1-5/16	1/2	1-1/32	1/2	1-5/16	3500
3/4	4-1/8	15/16	1-1/2	9/16	1-9/32	5/8	1-5/8	5200
7/8	4-27/32	1-1/8	1-3/4	11/16	1-15/32	3/4	1-7/8	7200
1	5-17/32	1-3/16	2-1/16	25/32	1-21/32	7/8	2-1/8	10000
1-1/4	7-3/16	1-3/4	2-13/16	1	2-3/32	1-1/8	2-5/8	15200
1-1/2	7-7/8	2-1/16	2-13/16	1-1/16	2-15/32	1-3/8	3-1/8	21400
1-3/4	9-3/8	2-1/8	3-3/8	1-1/4	2-29/32	1-5/8	3-1/2	28000
2	10-7/8	2-1/2	3-11/16	1-9/16	3-17/32	2	4-3/16	37000
2-1/2	13-11/16	2-7/8	4-7/16	1-9/16	4-5/8	2-1/4	5-5/8	60000
2-3/4	15	3-1/2	4-3/16	1-5/8	5-3/8	2-3/4	6-1/2	75000

ALLOY PEAR SHAPE LINK

- Quenched & Tempered Alloy Steel
- Unless noted otherwise, each link is individually proof tested to values shown on the certificate.
- Each link is shipped with a proof test certificate.
- Sizes 1" and under are drop forged. Sizes over 1" are welded and magnetic particle inspected.

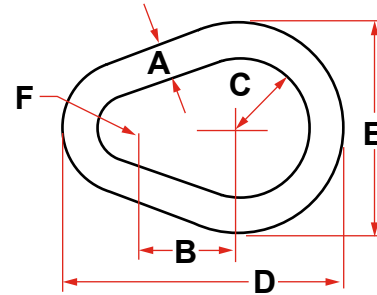

Never Exceed Working Load Limit.

SIZE A (INCHES)	WORKING LOAD LIMIT (LBS.)	PROOF LOAD (LBS.)	WEIGHT EACH (LBS.)	DIMENSIONS (INCHES)				
				B	C	D	E	F
1/2	7000	14000	0.55	1.50	1.00	4.00	3.00	0.50
5/8	9000	18000	1.10	1.88	1.25	5.00	3.75	0.63
3/4	12300	24600	1.76	2.25	1.50	6.00	4.50	0.75
7/8	14000	28000	2.82	2.63	1.75	7.00	5.25	0.88
1	24360	48700	4.22	3.00	2.00	8.00	6.00	1.00
1-1/8	30600	61200	6.25	3.38	2.25	8.75	6.75	1.13
1-1/4	36200	72400	8.25	3.75	2.50	10.00	7.50	1.25
1-3/8	43000	86000	11.25	4.13	2.75	11.00	8.25	1.38
1-1/2	54300	113200	14.25	4.50	3.00	12.00	9.00	1.50
1-5/8	62600	125200	18.50	4.88	3.25	13.00	9.75	1.63
1-3/4	84900	169800	22.50	5.25	3.50	14.00	10.50	1.75
1-7/8	95800	191600	29.00	5.63	3.75	15.00	11.25	1.88
2	102600	205200	34.00	6.00	4.00	16.00	12.00	2.00
2-1/4	143100	289200	48.00	6.75	4.50	18.00	13.50	2.25
2-1/2	160000	320000	66.00	7.50	5.00	20.00	15.00	2.50
2-3/4	216900	433800	88.00	8.25	5.50	22.00	16.50	2.75
3	228000	456000	114.00	9.00	6.00	24.00	18.00	3.00
3-1/4	262200	524400	146.00	9.75	6.50	26.00	19.50	3.25
3-1/2	279000	558000	181.00	10.50	7.00	28.00	21.00	3.50
4	373000	746000	271.00	12.00	8.00	32.00	24.00	4.00

ALLOY MASTER LINK

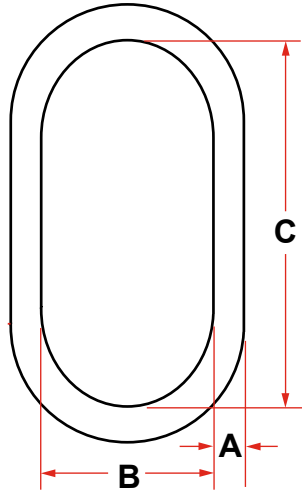

- Quenched & Tempered Alloy Steel
- Unless noted otherwise, each link is individually proof tested to values shown on the certificate. Proof tested according to ASTM A952 to avoid localized point loading.
- Each link is shipped with a proof test certificate.
- Sizes 2" and under are drop forged. Sizes over 2" are welded and magnetic particle inspected.

Never Exceed Working Load Limit.

SIZE A (INCHES)	WEIGHT (LBS.)			DIMENSIONS (INCHES)	
	WORKING LOAD LIMIT	PROOF LOAD	WEIGHT EACH	B	C
1/2	7000	14000	0.82	2.50	5.00
5/8	9000	18000	1.52	3.00	6.00
3/4	12300	24600	2.07	2.75	5.50
1	24360	48700	4.85	3.50	7.00
1-1/4	36200	72400	9.57	4.38	8.75
1-1/2	54300	113200	16.22	5.25	10.50
1-3/4	84900	169800	25.22	6.00	12.00
2	102600	205200	37.04	7.00	14.00
2-1/4	143100	289200	54.10	8.00	16.00
2-1/2	160000	320000	67.75	8.00	16.00
2-3/4	216900	433800	87.70	9.50	16.00
3	228000	456000	115.00	9.00	18.00
3-1/4	262200	524400	145.00	10.00	20.00
3-1/2	279000	558000	200.00	12.00	24.00
3-3/4	336000	672000	198.00	10.00	20.00
4	373000	746000	228.00	10.00	20.00
4-1/4	354000	708000	302.00	12.00	24.00
4-1/2	360000	720000	345.00	14.00	28.00
4-3/4	389000	778000	436.00	14.00	28.00
5	395000	790000	516.00	15.00	30.00

CHAIN HOOKS

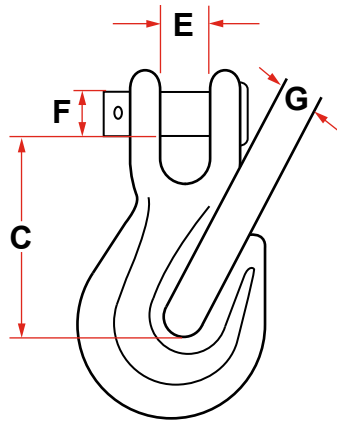

CLEVIS GRAB HOOK

SIZE OF CHAIN	RATED LOAD POUNDS			APPROXIMATE DIMENSIONS (INCHES)				WEIGHT POUNDS EACH
	HIGH TEST	TRANSPORT	LOW ALLOY	C	E	F	G	
1/4	2600	3150	3600	1-13/16	7/16	3/8	11/32	0.36
5/16	3900	4700	5400	2-5/32	1/2	7/16	7/16	0.60
3/8	5400	6600	7500	2-15/32	19/32	15/32	1/2	1.00
7/16	7200	8750	10000	2-25/32	21/32	9/16	9/16	1.31
1/2	9200	11300	12750	3-7/32	3/4	5/8	21/32	2.06
5/8	12750	16500	19000	4-3/32	29/32	3/4	25/32	4.25
3/4	18500		27000	4-5/8	15/16	7/8	15/16	7.19

WIRE ROPE CLIPS

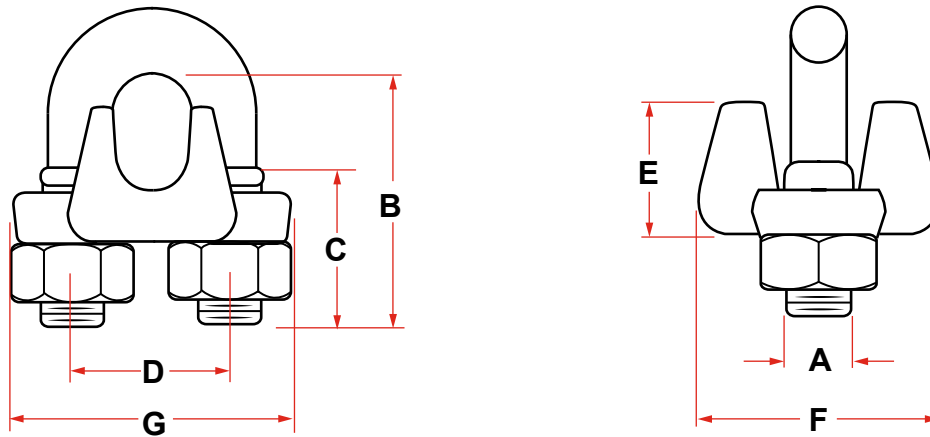

DROP FORGED U-BOLT TYPE

Meets Federal Specification FF-C-450 Type 1 Class-1.

CLIP AND ROPE SIZE (INCHES)	DIMENSIONS (INCHES)							MINIMUM NUMBER OF CLIPS REQUIRED	TORQUE IN FT. (LBS.)	MINIMUM ROPE TURNBACK (INCHES)	WEIGHT LBS. PER 100
	A	B	C	D	E	F	G				
1/8	7/32	23/32	7/16	15/32	13/32	13/16	15/16	2	4.5	3-1/4	5
3/16	1/4	31/32	9/16	19/32	1/2	15/16	1-5/32	2	4.5	3-3/4	9
1/4	5/16	1-1/32	1/2	3/4	21/32	1-3/16	1-7/16	2	15	4-3/4	18
5/16	3/8	1-3/8	3/4	7/8	23/32	1-5/16	1-11/16	2	30	5-1/4	30
3/8	7/16	1-1/2	3/4	1	29/32	1-5/8	1-15/16	2	45	6-1/2	42
7/16	1/2	1-7/8	1	1-3/16	1-1/32	1-13/16	2-9/32	2	65	7	70
1/2	1/2	1-7/8	1	1-3/16	1-1/8	1-29/32	2-9/32	3	65	11-1/2	75
9/16	9/16	2-1/4	1-1/4	1-5/16	1-7/32	2-1/16	2-1/2	3	95	12	100
5/8	9/16	2-3/8	1-1/4	1-5/16	1-11/32	2-1/16	2-1/2	3	95	12	100
3/4	5/8	2-3/4	1-7/16	1-1/2	1-13/32	2-1/4	2-27/32	4	130	18	150
7/8	3/4	3-1/8	1-5/8	1-3/4	1-19/32	2-7/16	3-5/32	4	225	19	240
1	3/4	3-1/2	1-13/16	1-7/8	1-25/32	2-5/8	3-15/32	5	225	26	250
1-1/8	3/4	3-7/8	2	2	1-29/32	2-13/16	3-19/32	6	225	34	310
1-1/4	7/8	4-1/4	2-1/8	2-5/16	2-3/16	3-1/8	4-1/8	7	360	44	460
1-3/8	7/8	4-5/8	2-5/16	2-3/8	2-5/16	3-1/8	4-3/16	7	360	44	520
1-1/2	7/8	4-15/16	2-3/8	2-19/32	2-17/32	3-13/32	4-7/16	8	360	54	590
1-5/8	1	5-5/16	2-5/8	2-3/4	2-21/32	3-5/8	4-3/4	8	430	58	730
1-3/4	1-1/8	5-3/4	2-3/4	3-1/16	2-15/16	3-13/16	5-9/32	8	590	61	980
2	1-1/4	6-7/16	3	3-3/8	3-9/32	4-7/16	5-7/8	8	750	71	1340
2-1/4	1-1/4	7-1/8	3-3/16	3-7/8	3-15/16	4-9/16	6-3/8	8	750	73	1570
2-1/2	1-1/4	7-11/16	3-7/16	4-1/8	4-7/16	4-11/16	6-5/8	9	750	84	1790
2-3/4	1-1/4	8-5/16	3-9/16	4-3/8	4-7/8	5	6-7/8	10	750	100	2200
3	1-1/2	9-3/16	3-7/8	4-3/4	5-11/32	5-5/16	7-5/8	10	1200	106	3200
3-1/2	1-1/2	10-3/4	4-1/2	5-1/2	6	6-3-16	8-3/8	12	1200	149	4000

Furnished in galvanized finish. Also Available in stainless steel and bronze.

HAWSER THIMBLES

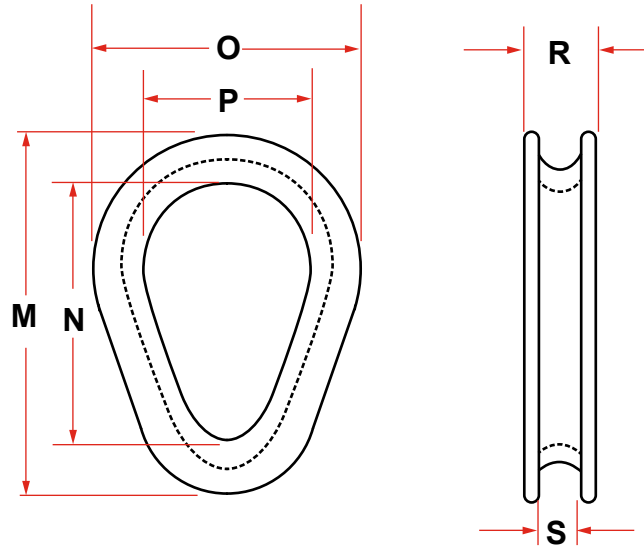

HEAVY DUTY HAWSER THIMBLE GALVANIZED OR SELF-COLORED

CAST, 1035 S

DIMENSIONS (INCHES)							WEIGHT (LBS.)
ROPE DIAMETER	M	N	O	P	R	S	
5/8 - 3/4	6-3/4	4-7/8	5	3	1-1/4	13/16	2-1/2
7/8 - 1	8-5/8	5-3/4	6-1/4	3-3/4	1-7/16	1-1/16	4-1/2
1-1/8 - 1-1/4	10-1/8	6-3/4	7-1/4	4-1/4	1-11/16	1-5/16	9
1-3/8 - 1-1/2	11-1/2	8	8-1/2	5	2-1/4	1-5/8	14
1-5/8 - 1-3/4	12-1/2	8	9-3/4	5	2-1/2	1-7/8	20
1-7/8 - 2	14-3/4	9-1/4	11-1/4	5-3/4	2-3/4	2-3/16	30
2-1/8 - 2-1/4	17	10-1/2	12-3/4	6-1/4	3-1/4	2-1/2	52
2-3/8 - 2-1/2	21	14-1/2	15-1/2	9-1/2	3-3/4	2-3/4	80
2-3/4 - 3	21	14-1/8	16	9	4-1/4	3-1/4	115

Larger Sized Available Upon Application.
Furnished with or without Reinforcement Plate (*Gusset). Cast Alloy Available upon Request.

WIRE ROPE THIMBLES

STANDARD WIRE ROPE THIMBLES, GALVANIZED STEEL

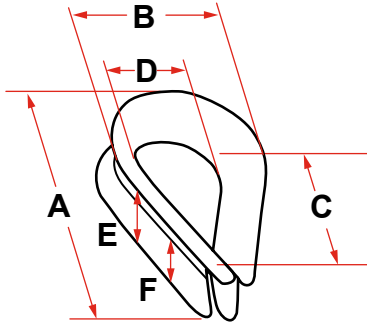

CLIP AND ROPE SIZE (INCHES)	DIMENSIONS (INCHES)						MAXIMUM PIN DIAMETER (INCHES)	WEIGHT LBS. PER 100
	A OVERALL	B OVERALL	C INSIDE	D INSIDE	E OVERALL	F INSIDE WIDTH OF SCORE		
1/8	1-15/16	1-1/16	1-5/16	11/16	1/4	5/32	5/8	3.3
3/16	1-15/16	1-1/16	1-5/16	11/16	5/16	7/32	5/8	3.4
1/4*	1-15/16	1-1/16	1-5/16	11/16	3/8	9/32	5/8	3.5
5/16*	2-1/8	1-1/4	1-1/2	13/16	7/16	3/8	3/4	4.0
3/8*	2-3/8	1-15/32	1-5/8	15/16	17/32	7/16	7/8	7.5
1/2*	2-3/4	1-3/4	1-7/8	1-1/8	11/16	9/16	1-1/16	15.8
5/8*	3-1/2	2-3/8	2-1/4	1-3/8	29/32	11/16	1-1/4	36.0
3/4	3-3/4	2-11/16	2-1/2	1-5/8	1-3/32	13/16	1-1/2	50.0
7/8	5	3-3/16	3-1/2	1-7/8	1-9/32	15/16	1-3/4	90.0
1	5-11/16	3-3/4	4-1/4	2-1/2	1-3/8	1-1/16	2-3/8	105.0
1-1/8 - 1-1/4	6-1/4	4-5/16	4-1/2	2-3/4	1-3/4	1-5/16	2-5/8	176.0
1-1/2	7-1/2	5-3/8	5	3-1/4	2-1/16	1-9/16	3-1/8	330.0
1-3/4	10-3/4	7-1/4	7-1/4	4-1/4	1-3/8	1-7/8	4-1/8	590.0
2	10-3/4	7-1/4	7-1/4	4-1/4	2-5/8	2-1/8	4-1/8	595.0

* Available in opened pattern. Suggested for light duty service only.

EXTRA HEAVY DUTY WIRE ROPE THIMBLES, GALVANIZED STEEL

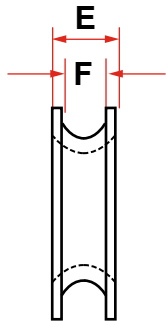
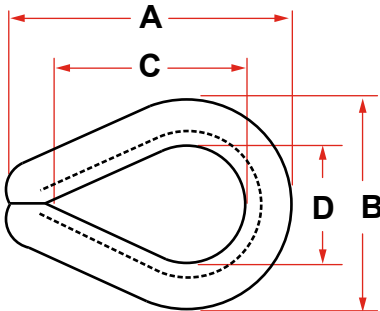

CLIP AND ROPE SIZE (INCHES)	DIMENSIONS (INCHES)						MAXIMUM PIN DIAMETER (INCHES)	WEIGHT LBS. PER 100
	A OVERALL	B OVERALL	C INSIDE	D INSIDE	E OVERALL	F INSIDE WIDTH OF SCORE		
1/4*	2-3/16	1-1/2	1-5/8	7/8	13/32	9/32	13/16	7.5
5/16*	2-1/2	1-13/16	1-7/8	1-1/16	1/2	11/32	15/16	14.0
3/8*	2-7/8	2-1/8	2-1/8	1-1/8	21/32	13/32	1-1/16	25.0
7/16	3-1/4	2-3/8	2-3/8	1-1/4	3/4	15/32	1-3/16	36.0
1/2*	3-5/8	2-3/4	2-3/4	1-1/2	27/32	17/32	1-7/16	51.0
9/16	3-5/8	2-11/16	2-3/4	1-1/2	29/32	19/32	1-7/16	52.0
5/8*	4-1/4	3-1/8	3-1/4	1-3/4	1	21/32	1-5/8	75.0
3/4*	5	3-13/16	3-3/4	2	1-1/4	25/32	1-7/8	147.0
7/8	5-1/2	4-1/4	4-1/4	2-1/4	1-3/8	15/16	2-1/8	185.0
1*	6-1/8	4-15/16	4-1/2	2-1/2	1-9/16	1-1/16	2-3/8	295.0
1-1/8 - 1-1/4	7	5-7/8	5-1/8	2-7/8	1-7/8	1-5/16	2-3/4	390.0
1-1/4 - 1-3/8	9-1/16	6-13/16	6-1/2	3-1/2	2-1/4	1-7/16	3-1/4	820.0
1-3/8 - 1-1/2	9	7-1/8	6-1/4	3-1/2	2-5/8	1-9/16	3-3/8	1175.0
1-5/8	11-1/4	8-1/8	8	4	2-3/4	1-23/32	3-7/8	1625.0
1-3/4	12-3/16	8-1/2	9	4-1/2	2-7/8	1-27/32	4-3/8	1800.0
1-7/8 - 2	15-1/8	10-3/8	12	6	3-1/8	2-3/32	5-7/8	2600.0
2-1/4	17-1/8	11-7/8	14	7	3-5/8	2-3/8	6-7/8	3880.0
2-1/2**	20-1/2	13-1/2	15-3/4	8-1/2	4-1/4	2-5/8	8-1/4	7500.0

* Available in stainless steel. A rugged rope thimble suggested for heavy duty services. ** Available in Cast Steel. Larger sizes available per request (with or without Gusset Plates).

REGULAR SWIVELS

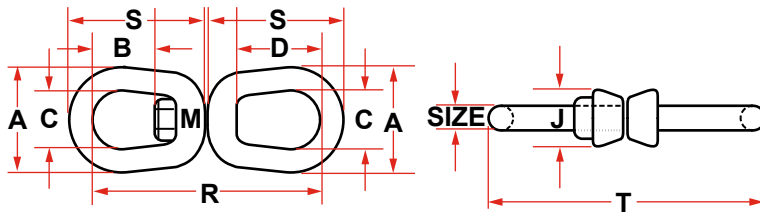

Hot Dip Galvanized
Quenched & Tempered

Meets the requirements of Federal
Specification RR-C-271D

SIZE (INCHES)	WORKING LOAD LIMIT (LBS.)	WEIGHT EACH (LBS.)	DIMENSIONS (INCHES)								
			A	B	C	D	J	M	R	S	T
1/4	850	0.21	1.25	0.69	0.75	1.06	0.69	0.31	2.94	1.69	3.44
5/16	1250	0.39	1.63	0.81	1.00	1.25	0.81	0.38	3.56	2.06	4.19
3/8	2250	0.75	2.00	0.94	1.25	1.50	1.00	0.50	4.31	2.50	5.06
1/2	3600	1.43	2.50	1.31	1.50	2.00	1.31	0.63	5.44	3.19	6.44
5/8	5200	2.50	3.00	1.56	1.75	2.38	1.50	0.75	6.56	3.88	7.81
3/4	7200	4.13	3.50	1.75	2.00	2.63	1.88	0.88	7.19	4.31	8.69
7/8	10000	6.25	4.00	2.06	2.25	3.06	2.13	1.00	8.38	5.00	10.13
1	12500	9.00	4.50	2.31	2.50	3.50	2.38	1.13	9.63	5.75	11.63
1-1/4	18000	16.37	5.63	2.69	3.13	3.69	3.00	1.38	11.13	6.75	13.35
1-1/2	45200	49.06	7.00	4.19	4.00	4.19	4.00	2.25	17.13	10.00	20.13

JAW END SWIVELS

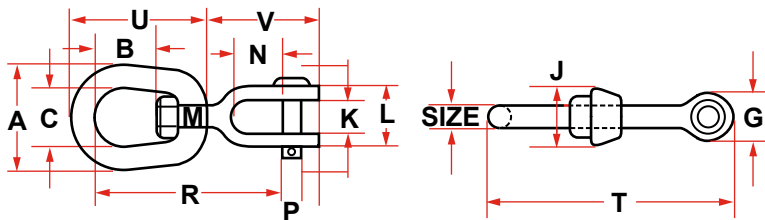

Hot Dip Galvanized
Quenched & Tempered

Meets the requirements of Federal
Specification RR-C-271D

SIZE (INCHES)	WORKING LOAD LIMIT (LBS.)	WEIGHT EACH (LBS.)	DIMENSIONS (INCHES)													
			A	B	C	G	J	K	L	M	N	P	R	T	U	V
1/4	850	0.25	1.25	0.69	0.75	0.69	0.69	0.47	1.03	0.31	0.88	0.25	2.63	3.38	1.69	1.69
5/16	1250	0.37	1.63	0.81	1.00	0.81	0.81	0.50	1.13	0.38	0.88	0.31	2.94	3.88	2.06	1.81
3/8	2250	0.70	2.00	0.94	1.25	1.00	1.00	0.63	1.41	0.50	1.06	0.38	3.63	4.75	2.50	2.25
1/2	3600	1.43	2.50	1.31	1.50	1.31	1.31	0.75	1.75	0.63	1.31	0.50	4.50	6.06	3.19	2.88
5/8	5200	2.48	3.00	1.56	1.75	1.63	1.50	0.94	2.06	0.75	1.50	0.63	5.31	7.31	3.88	3.44
3/4	7200	3.88	3.50	1.75	2.00	1.88	1.88	1.13	2.53	0.88	1.75	0.75	6.06	8.31	4.31	4.00
7/8	10000	5.75	4.00	2.06	2.25	2.13	2.13	1.19	2.75	1.00	2.06	0.88	7.00	9.53	5.00	4.53
1	12500	10.25	4.50	2.31	2.50	2.63	2.38	1.75	3.72	1.13	2.81	1.13	8.56	11.69	5.75	5.94
1-1/4	18000	15.75	5.69	2.69	3.13	3.13	3.00	2.06	4.31	1.38	2.81	1.38	9.44	13.13	6.75	6.38
1-1/2	45200	54.75	7.00	4.19	4.00	5.63	4.00	2.88	6.00	2.25	4.44	2.25	14.74	20.84	10.00	10.84

S181 EYE AND JAW SWIVEL

Stainless 316

DIMENSIONS (INCHES)				WORKING LOAD LIMIT (LBS.)	WEIGHT (LBS.)
SIZE (A)	B	C	D		
1/4	0.50	0.43	2.62	600	0.14
5/16	0.62	0.62	3.62	1100	0.33
3/8	0.75	0.87	4.62	1540	0.63
1/2	1.00	1.12	6.00	2640	1.40
5/8	1.25	1.37	7.37	4750	2.38
3/4	1.50	1.62	8.62	7000	3.93

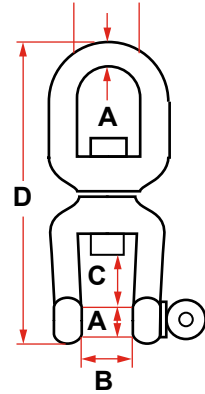

S0182 JAW AND JAW SWIVEL

Stainless 316

DIMENSIONS (INCHES)				WORKING LOAD LIMIT (LBS.)	WEIGHT (LBS.)
SIZE (A)	B	C	D		
1/4	0.50	0.43	2.50	600	0.15
5/16	0.62	0.62	3.50	1100	0.38
3/8	0.75	0.87	4.44	1540	0.74
1/2	1.00	1.12	5.88	2640	1.54
5/8	1.25	1.37	7.31	4750	2.63
3/4	1.50	1.62	8.63	7000	4.34

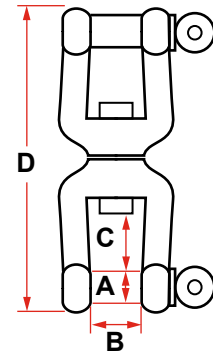

NOTE: COMMERCIAL TYPE

STAINLESS SCREW PIN ANCHOR SHACKLE

DIMENSIONS (INCHES)				LBS.	
A SIZE	B	C	D	WORKING LOAD LIMIT	WEIGHT
3/16	0.26	0.41	0.83	650	0.05
1/4	0.31	0.47	1.11	1000	0.10
5/16	0.38	0.53	1.20	1300	0.17
3/8	0.44	0.66	1.41	1500	0.30
7/16	0.50	0.72	1.77	2000	0.50
1/2	0.63	0.82	1.83	3000	0.71
5/8	0.75	1.02	2.41	4000	1.39
3/4	0.88	1.25	2.84	6000	2.31
7/8	1.00	1.48	3.30	8000	3.64
1	1.13	1.70	3.80	10000	5.18
1-1/4	1.38	2.03	4.69	14000	9.88

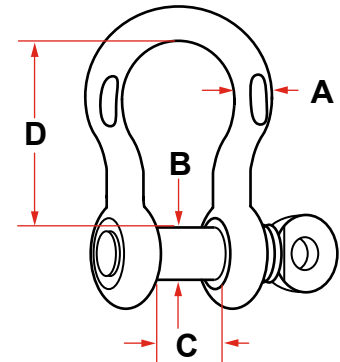

SCREW PIN

STAINLESS SAFETY ANCHOR SHACKLE

DIMENSIONS (INCHES)				LBS.	
A SIZE	B	C	D	WORKING LOAD LIMIT	WEIGHT
1/4	0.31	0.47	1.11	1000	0.12
5/16	0.38	0.53	1.20	1300	0.18
3/8	0.44	0.66	1.41	1500	0.35
7/16	0.50	0.72	1.77	2000	0.57
1/2	0.63	0.82	1.83	3000	0.84
5/8	0.75	1.02	2.41	4000	1.64
3/4	0.88	1.25	2.84	6000	2.75
7/8	1.00	1.48	3.30	8000	4.18
1	1.13	1.70	3.80	10000	5.61
1-1/4	1.38	2.03	4.69	14000	9.88

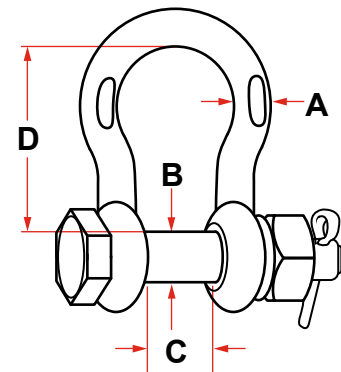

SAFETY TYPE

STAINLESS SAFETY CHAIN SHACKLE

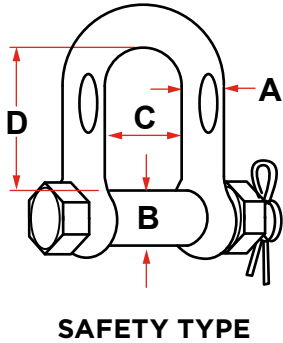

DIMENSIONS (INCHES)				LBS	
A SIZE	B	C	D	WORKING LOAD LIMIT	WEIGHT
5/32	0.17	0.32	0.55	200	0.02
3/16	0.19	0.37	0.69	500	0.03
1/4	0.23	0.47	0.82	750	0.05
5/16	0.31	0.62	1.10	1000	0.12
3/8	0.39	0.79	1.34	1200	0.23
1/2	0.47	0.95	1.65	1500	0.38

STAINLESS SCREW PIN CHAIN SHACKLE

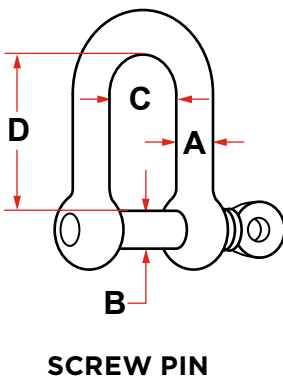

DIMENSIONS (INCHES)				LBS.	
A SIZE	B	C	D	WORKING LOAD LIMIT	WEIGHT
1/4	0.31	0.46	0.87	1000	0.11
5/16	0.38	0.52	1.02	1300	0.18
3/8	0.44	0.65	1.24	1500	0.31
7/16	0.50	0.75	1.43	2000	0.50
1/2	0.63	0.79	1.58	3000	0.74
5/8	0.75	1.05	1.94	4000	1.14
3/4	0.88	1.20	2.40	6000	2.36
7/8	1.01	1.45	2.88	8000	3.46
1	1.13	1.67	3.20	10000	4.85

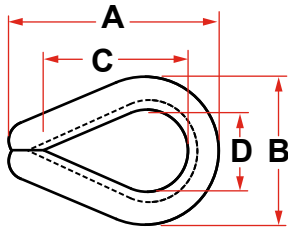

HEAVY DUTY WIRE ROPE THIMBLE

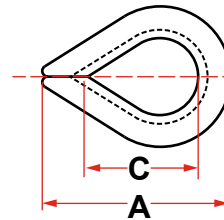
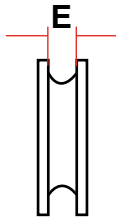

REGULAR WIRE ROPE THIMBLE

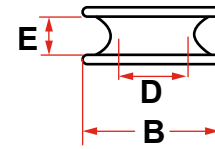

According to Federal Specification FF-C-450, Type III, Class I.

STAINLESS HEAVY DUTY WIRE ROPE THIMBLES - TYPE 304 & 316

SIZE (INCHES)	DIMENSIONS (INCHES)					APPROX. WEIGHT (LBS.)
	A	B	C	D	E	
1/4	2.19	1.50	1.63	0.88	0.44	0.08
5/16	2.50	1.88	1.88	1.13	0.50	0.10
3/8	2.88	2.09	2.09	1.13	0.66	0.25
1/2	3.63	2.63	2.75	1.50	0.88	0.45
5/8	4.25	3.09	3.25	1.75	1.00	0.68
3/4	5.00	3.50	3.75	2.00	1.25	1.20
7/8	5.66	4.19	4.31	2.25	1.50	1.85
1	6.13	4.63	5.00	2.50	1.56	2.20
1-1/8 - 1-1/4	7.13	5.33	5.38	2.88	1.88	3.80
1-1/4 - 1-3/8	8.38	6.67	6.50	3.50	2.25	8.60

STAINLESS REGULAR WIRE ROPE THIMBLES - TYPE 316

SIZE (INCHES)	DIMENSIONS (INCHES)					APPROX. WEIGHT (LBS.)
	A	B	C	D	E	
1/16						0.01
1/8	1.88	1.06	1.25	0.69	0.16	0.02
3/16	1.88	1.06	1.25	0.69	0.22	0.02
1/4	1.94	1.06	1.31	0.69	0.28	0.03
5/16	2.13	1.25	1.50	0.81	0.38	0.05
3/8	2.38	1.47	1.63	0.94	0.44	0.06
1/2	2.75	1.75	1.88	1.13	0.56	0.12
5/8	3.50	2.38	2.25	1.38	0.69	0.24

MARINE LANTERNS



SABIK 

MARINE LANTERNS

SELF-CONTAINED



SELF-CONTAINED LANTERN M650H
Self-contained LED lantern for buoys and minor beacons, 2 to 4+ NM range



SELF-CONTAINED LANTERN SC 155I
Self-powered LED lantern for buoys and minor beacons with 4 NM range



SELF-CONTAINED LANTERN SC 160I
Self-powered LED lantern for buoys and minor beacons with up to 8 NM range



SELF-CONTAINED LANTERN SC LS-100
Self-contained LED Light with 10 NM range

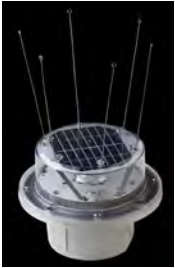

HYBRID LANTERN HBL 110
Unique Hybrid LED, lantern HBL 110 is a robust lantern to be used integrated into buoy applications
Standard range: 4 NM at $T_c = 0.74$
(5 NM at $T_c = 0.85$)



SELF-CONTAINED LANTERN M850
Solar Powered LED Marine Lantern up to 7.5 NM range



SELF-CONTAINED LANTERN SC 110
Marine self-contained LED light for buoys, beacons, marinas and aquaculture farms



SELF-CONTAINED LANTERN SC 155II
Self-contained LED Lantern for buoys and minor beacons



SELF-CONTAINED LANTERN SC 160II
SC 160II is a self-contained LED lantern with best in class optical performance for fixed and floating structures with longer range. Range up to 10 NM ($T_c=0.74$), 14 NM ($T_c=0.85$) depending on geographical location

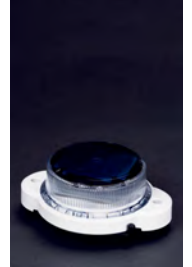

SELF-CONTAINED LANTERN M550
Solar Powered LED Marine Lantern up to 3 NM range



SELF-CONTAINED LANTERN M660
Self-contained LED lantern for buoys and minor beacons, up to 4 NM range



SELF-CONTAINED LANTERN M860
Solar Powered LED Marine Lantern up to 7.8 NM range

SABIK 

MARINE LANTERNS

LED SIGNALS FOR ALL APPLICATIONS



MARINE LANTERN LED 110
Marine LED light for buoys and small beacons with up to 4 NM range



MARINE LANTERN LED 160
Full Range Lantern for fixed and floating installations with three different lantern options available covering a range from 3 NM up to 12NM



ICE BUOY LANTERN MPV LED
Heavy Duty Ice Buoy LED light with Visual range from 2 to 6 NM



MARINE LANTERN LED 350 H
High Power LED light for fixed installations. A LED beacon capable of visual ranges up to 18 NM. LED 350H is designed to substitute rotating beacons with a considerably smaller power consumption



MARINE LANTERN LED 155
A general purpose LED lantern commonly used on both fixed and floating structures



ICE BUOY LANTERN VP LED
LED lantern designed to be used in moderate ice conditions



MARINE LANTERN LED 350
High intensity LED light for fixed installations. A high performance omni-directional LED precision beacon with arange of 15 nautical miles



SECTOR LIGHT OD SL 200
Omni-directional LED sector light. The range of the light, depending on color and flash character, is between 6 and 10 NM

SABIK 

M550

SOLAR POWERED LED MARINE LANTERN, 1 TO 3 NM RANGE

Leveraging custom optics, high-efficiency solar panels, and premium materials, this miniature solar LED marine lantern offers up to three times the range at half the size of its M502 predecessor. Now with replaceable, recyclable batteries this lantern provides excellent value and reliable operation over the long term. Battery life expectancy is five years with product life up to 15 years and a three-year warranty. Ideal for marine aids-to-navigation, marina lighting, dock lighting, and port lighting.

To view performance in your installation location, visit www.carmanahmarine.com/selector.

- 40 user-adjustable flash patterns and programmable intensities
- Replaceable, recyclable, high-temperature-rated NiMH AA batteries
- Automatic Light Control (ALC) 2.0; achieve optimal intensities throughout the year
- Premium grade, UV resistant polycarbonate body and lens material
- IP 68 rated
- Ventilated battery compartment

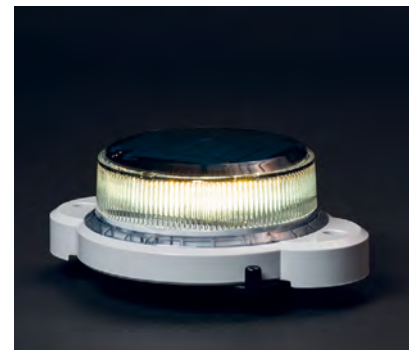

SABIK 

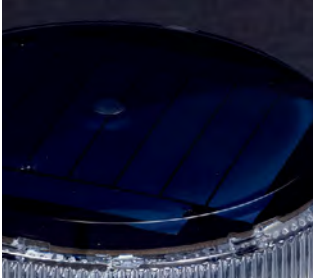

SOLAR MODULES

High-efficiency cells embedded in shatterproof polyurethane.

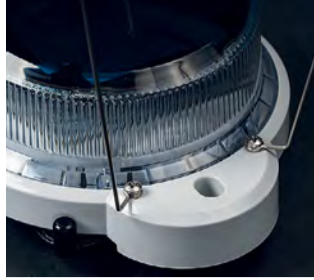

BIRD DETERRENT

Stainless steel bird deterrent available as accessory. Fits up to four per lantern.

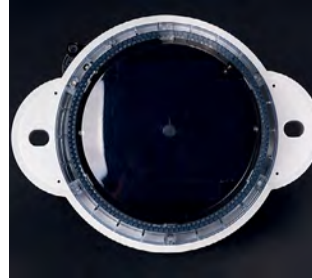

INSTALLATION

Simple installation using 2 x M6 bolts on a 127 mm diameter. No additional mounting hardware required.



POLE MOUNT

Easily adjusts to 2 3/8 inch, 60mm or 1 7/8 inch, 48 mm pole dimensions.



BATTERIES

Replaceable and recyclable NiMH batteries with extreme temperature range and 5-year life expectancy.



IR CONTROLLER

Check battery status, change flash code, adjust light intensity and turn lantern off with optional mini IR (Infrared) programmer.



EXTERNAL SWITCH

Optional external ON/OFF switch.

SABIK 

TECHNICAL SPECIFICATION M550

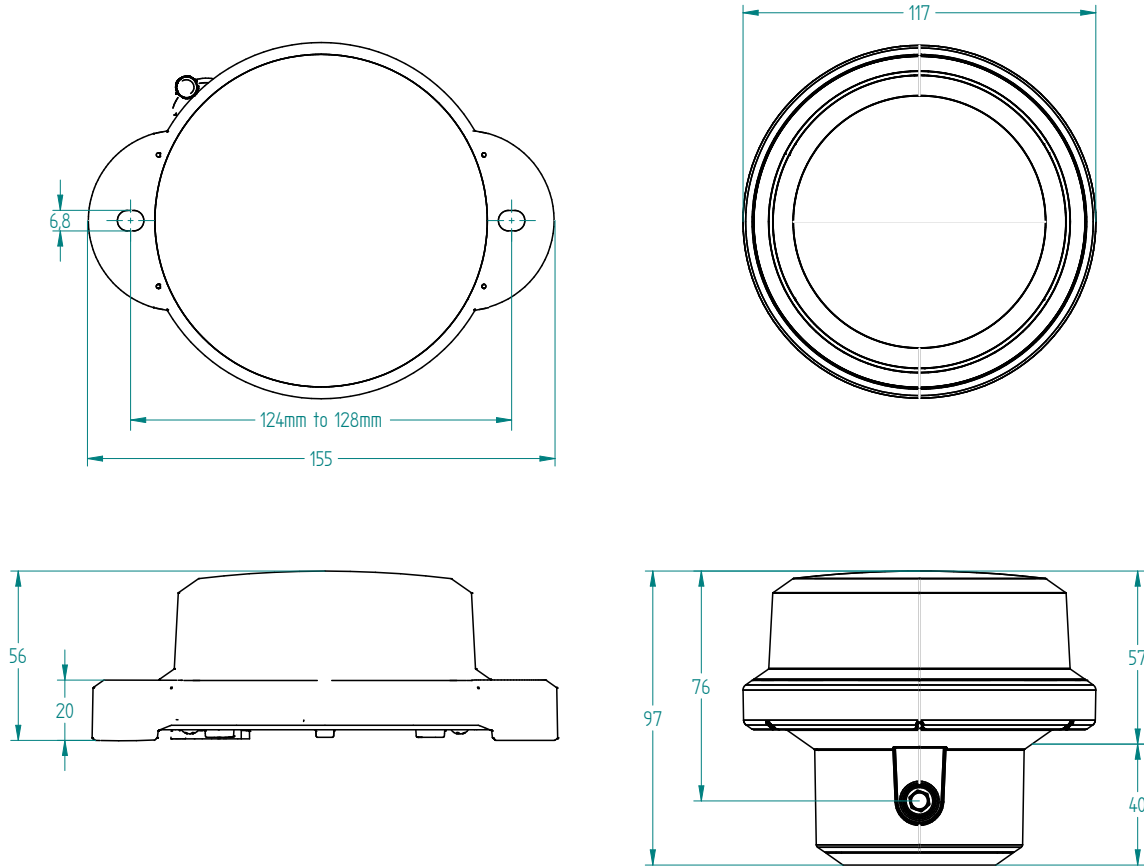

OPTICAL PERFORMANCE

Maximum fixed intensity

18 cd	23 cd	29 cd	25 cd	8 cd
-------	-------	-------	-------	------

Note: Peak IALA intensity dependent on location. To view performance in your installation location, visit www.carmanahmarine.com/selector.

SABIK 

MAIN TECHNICAL SPECIFICATION

Construction	Premium grade, UV resistant polycarbonate lens/head and polycarbonate/polysiloxane co-polymer base.
Lens visual/Mechanical diameter	102 mm
Lens material	UV stabilized polycarbonate
Light source	High Flux Surface Mount LED
Solar module	High efficiency cells
Battery	NiMH AA batteries
Degree of ingress protection	IP 68
Weight	Flange Mount: 0.37 kg (0.8 lbs) Pole Mount: 0.40 kg (0.9 lbs)
Overall height	56 mm (flange mount), 96 mm (pole mount)
Overall width	155 mm dia.
Installation	2 x M6 on 128 mm dia.

ORDER OVERVIEW M550

OPTION MATRIX

M550 Flange Mount - Switched	2-bolt mount with ON/OFF switch
M550 Flange Mount - Unswitched	2-bolt mount. No ON/OFF switch
M550 Pole Mount	Pole mount. No ON/OFF switch

ACCESSORIES

69935	Pole Mount Replacement/Conversion Kit
70943	Flange Mount Replacement/Conversion Kit
70937	Switched Kit (compatible with Flange Mount only)
70955	Replacement NiMH batteries
69934	Bird Deterrent (single)

PRODUCT CODES

Colour	M550 Flange unswitched	M550 Flange switched	M550 Pole
red	M55ORF	M55ORF-S	M55ORP
green	M55OGF	M55OGF-S	M55OGP
white	M55OWF	M55OWF-S	M55OWP
yellow	M55OYF	M55OYF-S	M55OYP
blue	M55OBF	M55OBF-S	M55OBP

SABIK 

M650H

SELF-CONTAINED LED LANTERN FOR BUOYS AND MINOR BEACONS, 2 TO 4+ NM RANGE

The M650H is a cost effective, self-contained, high-performance, low-maintenance and easy-to-install solar LED marine lantern. The M650H features a replaceable battery pack that extends the service life beyond five years, reducing the total cost of ownership. Applications include: marine aids-to-navigation marking, marina lighting, dock lighting, and port lighting. To view performance in your installation location, visit carmanahmarine.com/selector.

- Standard IALA colours Red, Green, White, Yellow, Blue
- High-efficiency solar cells with bypass and blocking diode function. Maximum power point tracking (MPPT) for optimal energy collection
- Premium grade UV resistant, polycarbonate/polysiloxane co-polymer body and lens material
- Colour-specific temperature corrected LED drivers provide consistent intensity under all operating conditions
- IP 68 rated. Double O-ring sealing with waterproof vent
- SLA battery
- Ventilated battery compartment
- Adjustable intensity and range
- Vertical divergence > 8° (FWHM)
- Programmable with On-Board User Interface, USB port, or optional wireless IR-Programmer
- Integrated event-log
- Optional ON/OFF switch
- Optional external charger
- Optionally integrated GPS synchronization

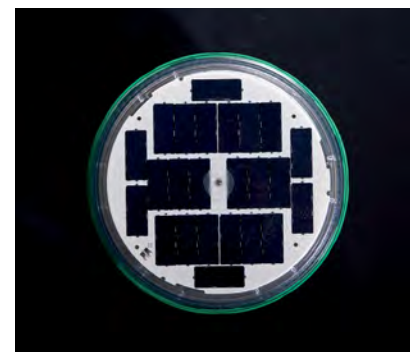

SABIK 



BIRD DETERRENT
Stainless steel as standard. Tool-less installation and replacement.

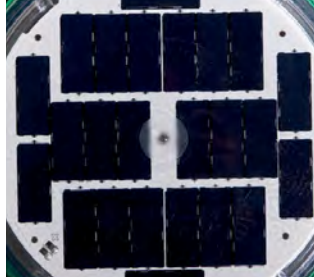

SOLAR MODULES
High-efficiency cells with bypass and blocking diode function. Maximum power point tracking (MPPT) for optimal energy collection.



SLA BATTERY
Tool-less replaceable and recyclable best-in-class battery pack with extreme temperature range and 5-year life expectancy. On-board battery status feedback of Good, Charge, Low or Replace. True battery voltage shown.



COLOUR INDICATOR
Protective bumper indicates LED colour.



ON-BOARD USER INTERFACE
Replaceable and recyclable NiMH batteries with extreme temperature range and 5-year life expectancy.



650 DEVICE MANAGER SOFTWARE
Check battery status, change flash code, adjust light intensity and turn lantern off with optional mini IR (Infrared) programmer.



IR CONTROLLER
Optional external ON/OFF switch.



INSTALLATION
Easily adjusts to 2 3/8 inch, 60mm or 1 7/8 inch, 48 mm pole dimensions.



BOTTOM COVER REMOVAL TOOL
Available as accessory.



BARGE APPLICATION
For barge application, sector plates with open sectors of 112,5°, 135° and 225°.

TECHNICAL SPECIFICATION M650H

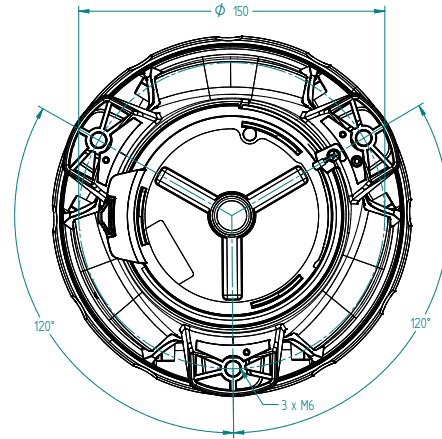
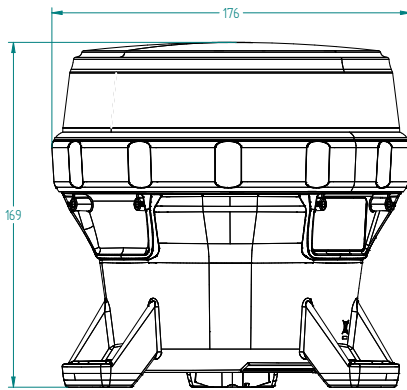

OPTICAL PERFORMANCE

Maximum fixed intensity

31 cd

45 cd

60 cd

52 cd

15 cd

Note: Peak IALA intensity dependent on location. To view performance in your installation location, visit www.carmanahmarine.com/selector.

MAIN TECHNICAL SPECIFICATION

Lens visual/Mechanical diameter	165 mm
Lens material	UV stabilized Polycarbonate
Light source	High Power Light Emitting Diode (LED)
Vertical divergence	>8° (FWHM)
Solar module	High efficiency cells; bypass and blocking diodes; MPPT
Battery	Sealed Lead Acid
Degree of ingress protection	IP 68
Weight	1.58 kg
Overall height	169 mm
Overall width	176 mm dia.
Installation	3 x M6 on 150 mm dia.

SABIK 

ORDER OVERVIEW M650H

OPTION MATRIX

M650H Switched	ON/OFF switch
M650H Unswitched	No ON/OFF switch
M650H Switched GPS	Includes GPS synchronization & ON/OFF switch
M650H Unswitched GPS	Includes GPS synchronization (no ON/OFF switch)

ACCESSORIES

57003	650 Bird Deterrent - Additional (1 ships with each lantern)
57392	650 Bottom Cover Replacement Pack Switched
57393	650 Bottom Cover Replacement Pack Unswitched
59198	650 Bottom Cover Removal Tool
72835	650 Battery Replacement Pack
59188	650 International Wall Charger Assembly
57394	650 USB Cable
69899	IR (Infrared) Programmer
38334	650 Standard Bolt Kit
64407	650 Security Mounting Bolt Kit (Includes drivers)
56578	650 Security Bolt and Nut Set (Drivers not included)
53284	500/650 Security Key
53285	500/650 Security Socket

PRODUCT CODES

Colour	M650H unswitched	M650H switched	M650H unswitched GPS	M650H switched GPS
red	M650R	M650R-S	M650R-GPS	M650R-SGPS
green	M650G	M650G-S	M650G-GPS	M650G-SGPS
white	M650W	M650W-S	M650W-GPS	M650W-SGPS
yellow	M650Y	M650Y-S	M650Y-GPS	M650Y-SGPS
blue	M650B	M650B-S	M650B-GPS	M650B-SGPS

SABIK 

M660

SELF-CONTAINED LED LANTERN FOR BUOYS AND MINOR BEACONS, UP TO 4 NM RANGE

The M660 is a high-performance, long life, easy-to-use and cost effective self-contained solar LED marine lantern. The M660 features a Li-ion battery pack that extends the service life of the lantern up to eight years. M660 has four different mounting options and can be programmed and controlled with Bluetooth® Control. To view performance in your installation location, visit Marine Selector Tool at www.carmanahmarine.com/selector.

- Standard IALA colours Red, Green, White, Yellow, Blue
- Ventilated battery compartment
- Adjustable intensity and range
- Vertical divergence > 8° (FWHM)
- High-efficiency solar cells. Maximum Power Point Tracking (MPPT) for optimal energy collection
- Premium grade UV resistant, polycarbonate/polysiloxane co-polymer body and lens material
- IP 68 rated. O-ring sealing with waterproof vent. Battery case is also IP68 (duration under test)
- Li-ion battery, optional dual pack
- Programmable with Bluetooth® Control and IR-Programmer
- Optional ON/OFF switch, external charger and charging port

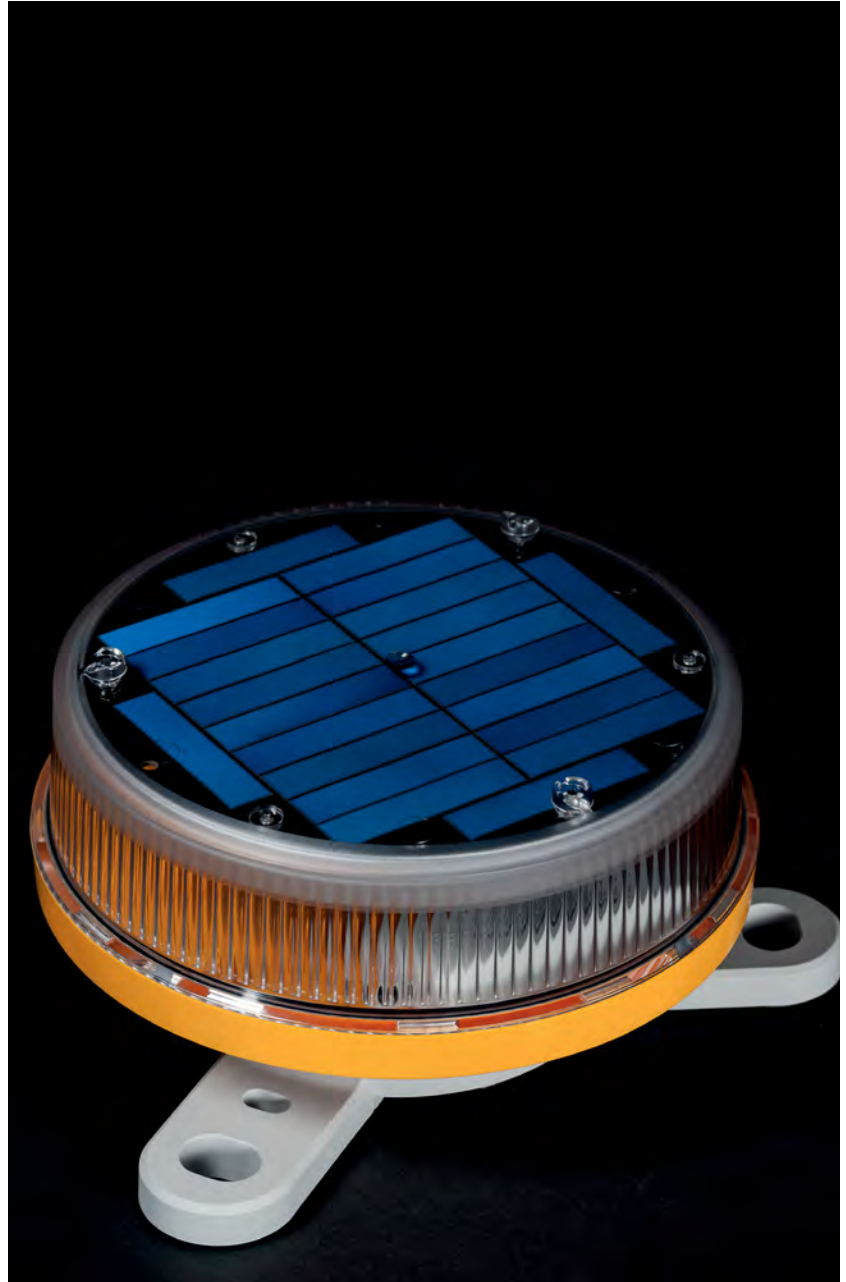

SABIK 

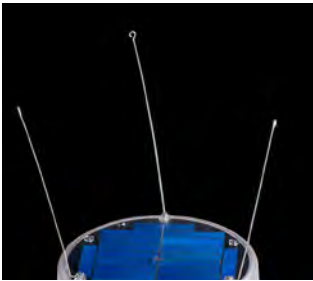

BIRD DETERRENTS
Stainless steel as standard.



SOLAR MODULES
High-efficiency cells.
Maximum Power Point
Tracking (MPPT) for optimal
energy collection.



LI-ION
Replaceable Li-ion battery
pack with extreme
temperature range and up
to 8-year life expectancy.



COLOUR INDICATOR
Protective bumper
indicates
LED colour.



INSTALLATION
Four different mounting
options Dual bolt circles
standard (150 and 200
mm, 3 holes). Two pole
mounting options.



POLE MOUNT
Pole mount by removing
adapter. 2.5" or 6 cm
diameter and smaller and 4"
or 10 cm diameter (nominal,
sched. 40)

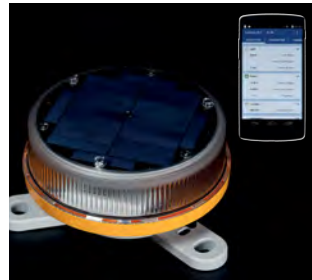

BLUETOOTH® CONTROL
Lantern can be
programmed and battery
status checked up to 50
meters distance with an
app for Android and iOS.



IR CONTROLLER
Set intensity, change flash
code, check battery status,
set ship mode and turn
lantern off with optional IR
(Infrared) controller.



EXTERNAL SWITCH
An optional external switch
can be installed.

TECHNICAL SPECIFICATION M660

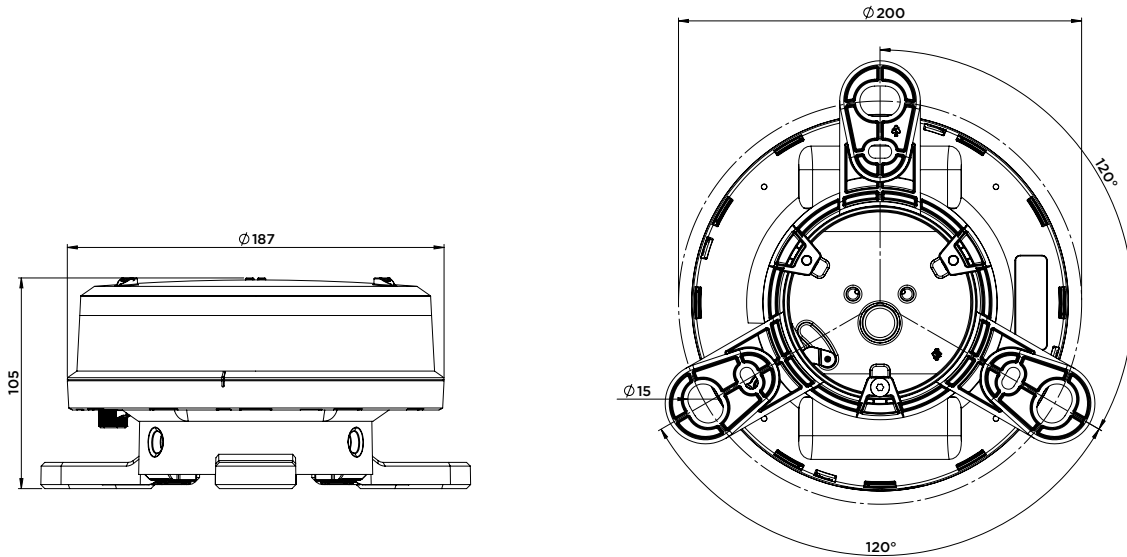

OPTICAL PERFORMANCE

Maximum fixed intensity

40 cd

42 cd

71 cd

52 cd

18 cd

Note: Peak IALA intensity dependent on location. To view performance in your installation location, visit www.carmanahmarine.com/selector.

MAIN TECHNICAL SPECIFICATION

Lens visual/Mechanical diameter	177 mm
Lens material	UV stabilized Polycarbonate
Light source	High Power Light Emitting Diode (LED)
Vertical divergence	>8° (FWHM)
Solar module	High efficiency cells; MPPT
Battery	Li-ion (IEC 61233)
Degree of ingress protection	IP 68
Weight	0.8 kg
Overall height (excl. bird deterrents)	105 mm
Installation (adapter)	3 x M6 on 150mm and 3 x M12 on 200mm
Installation (pole mount)	3 x #10-14 60mm or 73mm diameter

SABIK 

ORDER OVERVIEW M660

OPTION MATRIX

M660 Switched	ON/OFF switch
M660 Unswitched	No ON/OFF switch
M660 Dual Battery	Dual Battery Pack
M660 Charge Port	With Charge Port

ACCESSORIES

69934	660 Bird Deterrent - Single
79848	Spare adapter (incl. screws)
79273	Optional switch
79399	660 Battery Replacement Pack
69885	660 International Wall Charger Assembly
69899	IR (Infrared) Programmer
38334	660 Standard Bolt Kit
79400	660 Dual Battery Replacement Pack

PRODUCT CODES

Colour	M660 unswitched	M660 switched	M660 dual battery	M660 charge port
red	M660R	M660R-S	M660R-2B	M660R-C
green	M660G	M660G-S	M660G-2B	M660G-C
white	M660W	M660W-S	M660W-2B	M660W-C
yellow	M660Y	M660Y-S	M660Y-2B	M660Y-C
blue	M660B	M660B-S	M660B-2B	M660B-C

Product code example: M660RSC2B

- **M660R** is Sabik/Carmanah code for M660 in red with a selection of switched with charge port and dual battery

SABIK 

M850

SOLAR POWERED LED MARINE LANTERN, 3 TO 6+ NM RANGE

The M850 combines a compact, high-efficiency solar engine with premium components and a rugged design for best-in-class performance at an optimal price. This lantern is suitable for use in most solar locations. To view performance in your installation location, visit www.carmanahmarine.com/selector.

- Option for standard or wide divergences (for fixed or floating applications)
- Multiple cost-effective battery pack options suitable for a wide variety of installation locations
- Built-in calendar function for automatic de-activation during off-season months
- Top-mounted 4-character LED display with simple »tap to activate« functionality
- Premium grade, UV resistant polycarbonate lens material
- Environmentally friendly, super durable powder-coated aluminium chassis
- Adjustable intensity and range
- IP 68 rated
- GPS synchronized flash option

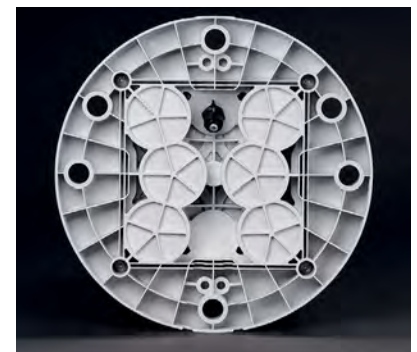
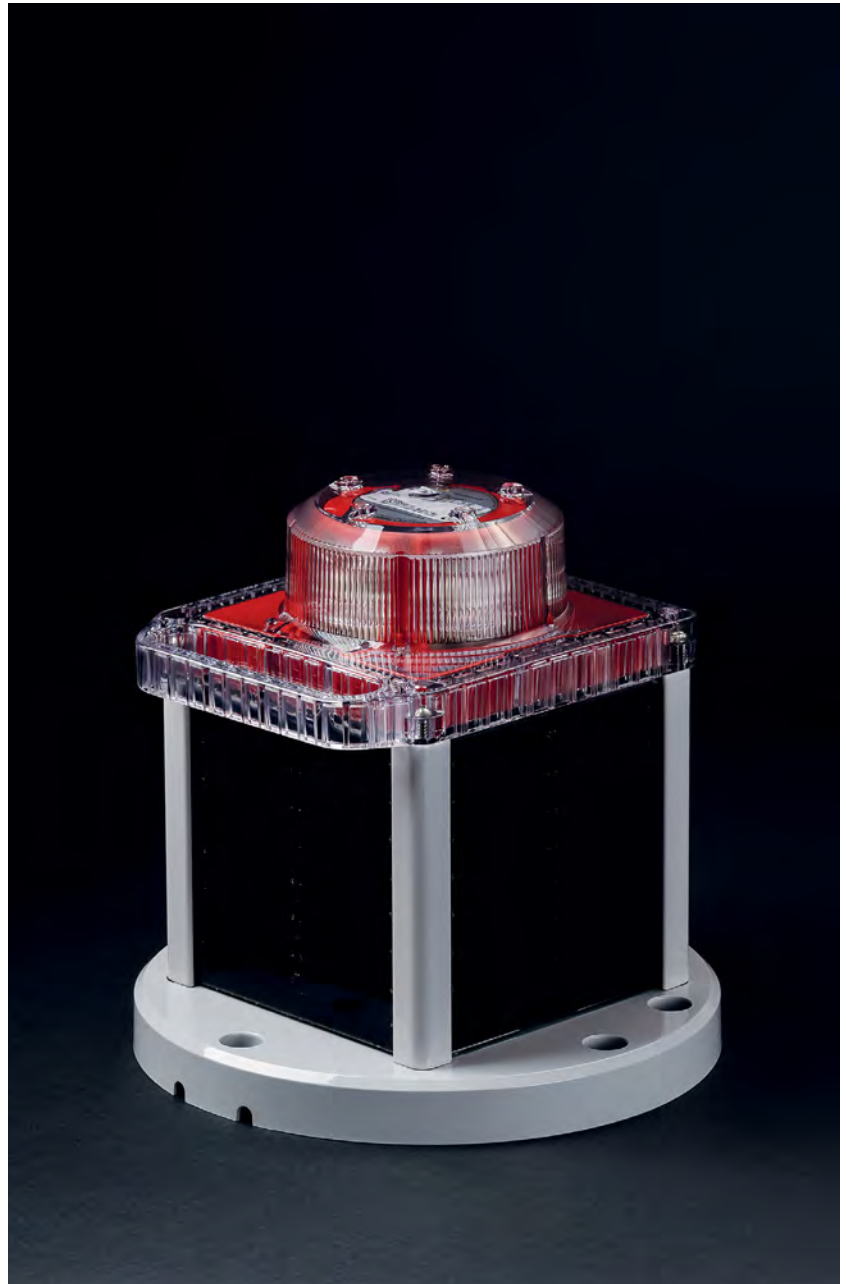

SABIK 



TOP-MOUNTED DISPLAY
Easily check light settings with a »tap-to-activate« digital display.



INFRARED PROGRAMMER
Check battery state of charge, program flash codes, set intensities and more.

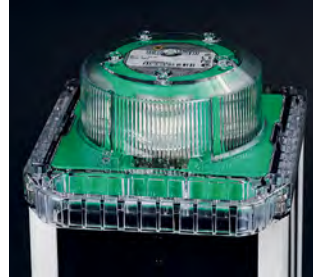

OPTICAL ASSEMBLY
Durable, UV resistant optical lens with options for standard (8°) or wide (10°) divergence.



SCALABLE BATTERY PACK
Multiple replaceable, recyclable battery pack options for reliable, cost-effective performance in a variety of installation locations.



VISIBLE COLOUR INDICATOR
LED colour is clearly indicated by the colour of the lantern head.



EXTERNAL CHARGE PORT
Optional charge port in the lantern base allows for easy overnight charging via wall plug.



INSTALLATION
Supports installation on structure using 3 x M12 bolts, 4 X M12 bolts, or 5 x M12 bolts on a 200 mm diameter. Standard and security bolt kits are available.

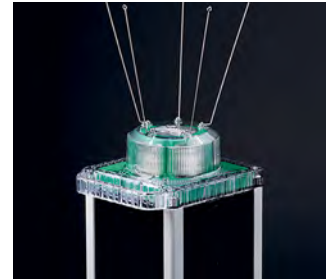

BIRD DETERRENT
Stainless steel bird deterrent. Five deterrents supplied with option for up to ten per lantern.

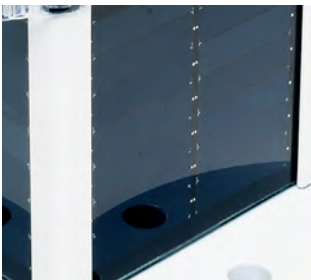

SOLAR MODULES
High efficiency cells protected by rugged powder-coated aluminium extrusion.

SABIK 

TECHNICAL SPECIFICATION M850

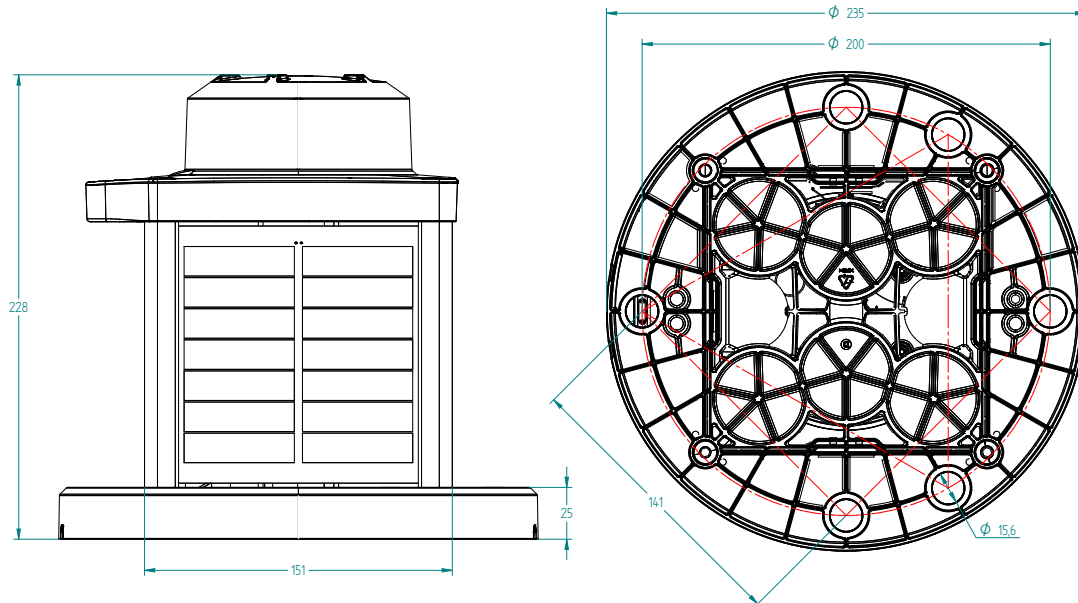

OPTICAL PERFORMANCE				
Maximum fixed intensity				
M850	239 cd	290 cd	445 cd	320 cd

Note: Peak IALA intensity dependent on location. To view performance in your installation location, visit www.carmanahmarine.com/selector.

MAIN TECHNICAL SPECIFICATION

Lens visual/Mechanical diameter	111 mm
Construction	Premium grade, UV resistant polycarbonate lens/head and polycarbonate/polysiloxane co-polymer base
Light source	High Flux Surface Mount LEDs with colour-specific temperature-corrected LED driver
Solar modules	High-efficiency cells; MPPT
Battery	Multiple replaceable, recyclable battery options (refer to options matrix)
Degree of ingress protection	IP 68 immersion
Weight	4.5 kg M850 60X 5.3 kg M850 96E
Overall height	226 mm
Overall width	235 mm dia.
Installation	3, 4, or 5 x M12 on 200 mm dia.

SABIK 

ORDER OVERVIEW M850

OPTION MATRIX					
Model	Colour Options	Battery	Lens	Control	Charge Port
M850	Red	60X	Standard (8°)	GPS Sync	With External Chargeport
	White				
	Green	96E	Wide (10°)	Non-GPS Sync	Without External Chargeport
	Yellow				

ACCESSORIES

71757	M800 Series Standard Bolt Kit
71884	M800 Series Security Bolt Kit (drivers not included)
53288	M800 Series Security Key
53289	M800 Series Security Socket
69885	M800 Series AC/DC 12V-2.5A Charger, International Plug Adapters
69934	Bird Deterrent (single)
69954	M800 Series Battery Replacement Kit - 60 Wh
69955	M800 Series Battery Replacement Kit - 96 Wh
HEAD KIT	M800 Series Head Replacement Kit (please specify colour at time of order)
HEAD KIT GPS	M800 Series GPS Head Replacement Kit (please specify colour at time of order)
69899	Remote Control

PRODUCT CODES

Colour	M850 60X (with 60Wh battery)	M850 96E (with 96Wh battery)	M850 60X GPS (with 60Wh battery)	M850 96E GPS (with 96Wh battery)
red	M850R-60X	M850R-96E	M850R-60XGPS	M850R-96EGPS
green	M850G-60X	M850G-96E	M850G-60XGPS	M850G-96EGPS
white	M850W-60X	M850W-96E	M850W-60XGPS	M850W-96EGPS
yellow	M850Y-60X	M850Y-96E	M850Y-60XGPS	M850Y-96EGPS

SABIK

SOCKETS

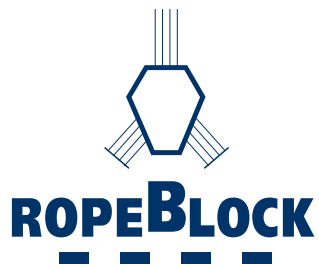

WARNINGS & APPLICATION INSTRUCTIONS

GENERAL

Safety measures should be taken into account when using our sockets. Carefully follow all installation instructions. Important measures can be found below.

SPELTER SOCKETS

- Proper spelter socket terminations have an efficiency equal to the breaking load of the wire. This can be limited by the minimum breaking load of the socket (MBL), as mentioned in the tables
- Please read the instructions of the resin manufacturer carefully before use. Incorrect use of the resin or spelter material can result in an unsafe termination. More information can also be obtained from your wire rope supplier
- Always remove any dirt and grease from the wire rope broom and socket basket
- Ensure that the broomed wires are evenly spaced in the basket and that the wire and basket are aligned with each other
- When using white metal or zinc, the socket may be preheated to 300°C (570°F), but never over 350°C (660°F)
- Make sure the base of the socket is properly sealed. This to prevent resin leakage, which may cause voids
- Never use an assembly before the resin is fully hardened
- Procedures in EN 13411-4, ISO 17558 or equivalent should be followed
- Socketing shall always be executed by competent personnel only

FAST CONNECTOR SOCKETS

- The FCS Spin Resistant connector shall be used with non-rotation resistant wire rope and may be used with rotation resistant wire rope
- The FCS standard (rotating) connector shall be used with non-rotating or rotation resistant wire rope only
- Socketing of the connector shall be executed by competent personnel only. Normal socketing procedures for spelter sockets shall be followed

WARNINGS

- Always carry out a visual inspection before using a socket and pin.
- Never use a part showing cracks.
- Do not side-load a socket.
- Repairs are not allowed, for any repairs contact your supplier.
- Never shock-load a socket.

Required resin volume for socketing wire rope terminations

FOR WIRE ROPE Ø		APPROXIMATE RESIN VOLUME
MM	INCH	CC
6 - 7	1 5/8	9
8 - 10	1 3/4 - 1 7/8	15
11 - 13	2 - 2 1/8	35
14 - 16	2 1/4 - 2 3/8	50
18 - 19	2 1/2 - 2 5/8	80
20 - 22	2 3/4 - 2 7/8	120
23 - 26	3 - 3 1/8	160
27 - 30	3 1/4 - 3 3/8	220
31 - 36	3 1/2 - 3 5/8	350
37 - 39	3 3/4 - 4	425
40 - 42	4 1/4 - 4 1/2	500
43 - 48	4 3/4 - 5	700
49 - 54	6 3/4 - 7	1200
55 - 60	7 1/4 - 7 1/2	1450
61 - 68	7 3/4 - 8	1850
69 - 75	9	2250
76 - 80	15	3500
81 - 86	35	4000
87 - 93	50	5000
94 - 102	80	7500
108 - 115	120	10500
120 - 130	160	14000
135 - 140	220	16000
141 - 153	350	20000
154 - 165	425	26000
166 - 178	500	33000
179 - 191	700	39000
192 - 204	1200	48000

WARNINGS & APPLICATION INSTRUCTIONS

SUPER REEVE CONNECTOR SOCKETS

- The SCS Spin Resistant connector shall be used with non-rotation resistant wire rope and may be used with rotation resistant wire rope
- The SCS standard (rotating) connector shall be used with non-rotating or rotation resistant wire rope only
- Socketing of the connector shall be executed by competent personnel only Normal socketing procedures for spelter sockets shall be followed
- The connector cap shall be secured after socketing by means of a high strength thread locking adhesive
- The connector cap is not a lifting device; it is used to pull the connector through the reeving system with a standard shackle
- The connector shall always be installed and used with the retainer properly installed

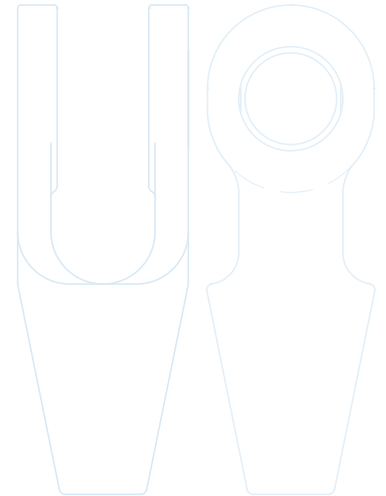

WEDGE SOCKETS

- Always mount the loaded part of the wire in the centre line of the pin (see figures below)
- Secure properly the dead end with a wire rope clip
- Do not attach the dead end to the live wire
- The dead end should have a length of 6 times the wire diameter with a minimum of 150 mm
- Ensure that the wire rope and wedge are fully seated after the first load
- A load may slip if the connection is not properly installed
- Inspect the connection regularly
- The efficiency of a 6 or 8 strand wire rope and most high performance ropes with a Ropeblock wedge socket connection is 80% of the MBL of the wire rope, but limited to the MBL of the socket
- Check your wire rope supplier for efficiency rating details when used with high performance ropes and test the assembly to determine efficiency
- Nominal intermediate rope sizes should be used with the biggest socket within the range

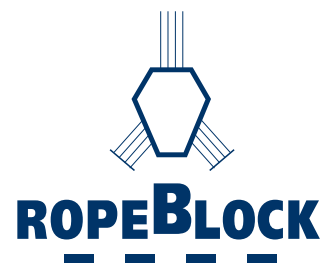
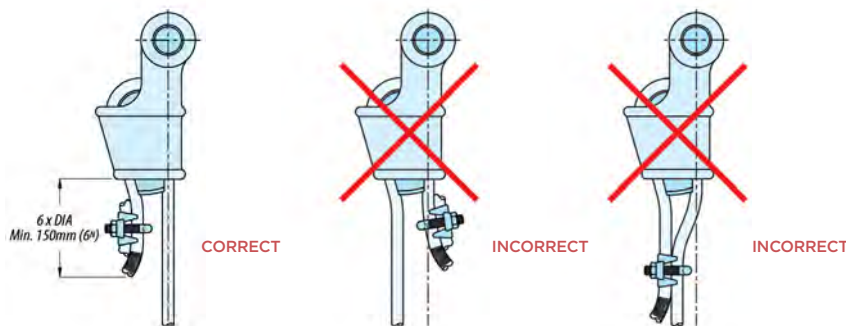

OPEN SPELTER SOCKETS WITH PIN QUENCHED AND TEMPERED CAST STEEL

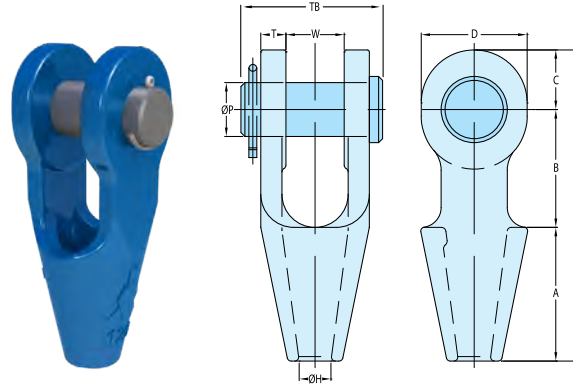

MODEL NR.	MBL (USTONS)	FOR WIRE		STRAND		DIMENSIONS (INCH)										WEIGHT (LBS)
		MM	INCH	MM	INCH	A	B	C	D	Ø H	Ø P	T	TL	TB	W	
OSS 196 P	9	6-7	¼	-	-	1 15/16	1 9/16	¾	1 5/16	¾	5/8	¾	4 5/16	2	¾	0.9
OSS 197 P	13	8-10	⅜	-	-	2 ¼	1 ¾	7/8	1 5/8	½	13/16	7/16	4 7/8	2 ½	1 1/16	1.5
OSS 198 P	22	11-13	7/16 - ½	-	-	2 ½	2	1 1/16	1 5/16	9/16	1	7/16	5 9/16	2 5/8	1	2.2
OSS 199 P	28	14-16	9/16 - 5/8	13	½	3	2 ½	1 ¼	2 5/16	1 1/16	1 1/16	9/16	6 ¾	3 3/8	1 ¼	4.0
OSS 100 P	44	18-19	¾	14-16	9/16 - 5/8	3 ½	3	1 7/16	2 ¾	7/8	1 3/8	5/8	8 1/16	3 ¾	1 ½	7
OSS 104 P	61	20-22	7/8	18-19	¾	4	3 ½	1 ¾	3 5/8	1	1 5/8	¾	9 ¼	4 5/16	1 ¾	10
OSS 108 P	83	23-26	1	20-22	7/8	4 ½	4	2 3/8	4 1/8	1 1/8	2	7/8	10 13/16	5 1/16	2	18
OSS 111 P	99	27-30	1 1/8	23-26	1	5	4 ½	2 9/16	4 ½	1 5/16	2 ¼	1	12 1/16	5 5/16	2 ¼	24
OSS 115 P	138	31-36	1 ¼ - 1 3/8	27-28	1 1/16 - 1 1/8	5 ½	5	2 13/16	4 15/16	1 1/16	2 ½	1 1/8	13 9/16	6 1/8	2 ½	34
OSS 118 P	165	37-39	1 ½	30-32	1 3/16 - 1 ¼	6	6 3/8	3 3/8	5 5/16	1 1/16	2 ¾	1 3/16	15 ½	6 15/16	3	48
OSS 120 P	187	40-42	1 5/8	33-35	1 5/16 - 1 3/8	6 ½	6 ½	3 7/16	6 1/8	1 13/16	3	1 5/16	16 7/16	7 3/8	3	60
OSS 125 P	248	43-48	1 ¾ - 1 7/8	36-40	1 7/16 - 1 5/8	7 ½	7	3 19/16	6 15/16	2 1/16	3 ½	1 9/16	18 7/16	8 7/16	3 ½	90
OSS 128 P	309	49-54	2 - 2 1/8	42-45	1 5/8 - 1 ¾	8 ½	9	4 ¼	7 5/8	2 5/16	3 ¾	1 ¾	21 ¾	9 5/8	4	132
OSS 130 P	397	55-60	2 ¼ - 2 3/8	46-48	1 13/16 - 1 7/8	9	10	4 ¾	8 ¼	2 9/16	4 ¼	2 1/16	23 ¾	10 13/16	4 7/16	194
OSS 132 P	468	61-68	2 ½ - 2 5/8	50-54	2 - 2 1/8	9 ¾	10 ¾	5 ¼	9 5/16	2 15/16	4 ¾	2 3/8	25 ¾	11 13/16	5	261
OSS 135 P	507	69-75	2 ¾ - 2 7/8	56-62	2 ¼ - 2 ½	11	11	5 7/16	9 7/16	3 3/16	5	2 7/8	27 3/8	13 3/16	5 ¼	342
OSS 138 P	617	76-80	3 - 3 1/8	64-67	2 ½ - 2 5/8	12	11 ¼	5 ¾	9 15/16	3 ½	5 ¼	3	29	14	5 ¾	410
OSS 140 P	689	81-86	3 ¼ - 3 3/8	69-76	2 ¾ - 3	13	11 ¾	6 5/16	11 7/16	3 5/8	5 ½	3 1/8	31	14 ¾	6 ¼	499
OSS 142 P	794	87-93	3 ½ - 3 5/8	78-86	3 1/16 - 3 3/8	14	12 ½	7	12 5/8	3 7/8	6	3 ¼	33 ½	15 ¾	6 ¾	624
OSS 144 P	965	94-102	3 ¾ - 4	88-96	3 7/16 - 3 ¾	15	13 ½	7 ½	13 ¾	4 ¼	7	3 ½	36	17 1/8	7 ½	825
OSS 146 P	1323	108-115	4 ¼ - 4 ½	98-110	3 7/8 - 4 3/16	17 1/16	18 7/8	8 7/16	15 ¾	5 1/16	7 1/16	3 15/16	45 1/16	18 5/16	8 3/16	1188
OSS 150 P	1543	120-130	4 ¾ - 5	112-124	4 3/16 - 4 3/8	19 1/16	19 11/16	9 13/16	17 11/16	5 13/16	8 11/16	4 5/16	49 3/16	20 11/16	8 7/8	1678
OSS 155 P	1764	135-140	5 ¼ - 5 ½	125-132	4 15/16 - 5 3/16	21 ¼	19 9/16	10 3/8	18 7/8	6 1/16	9 7/16	5 ½	51 3/16	23 ¼	9 1/16	2352
OSS 160 P	2205	142-153	5 ¾ - 6	133-143	5 ¼ - 5 5/8	23 1/16	19 7/8	10 13/16	19 13/16	6 ¾	10 1/16	5 ½	53 ¾	24	9 13/16	2584
OSS 165 P	2447	154-165	6 ¼ - 6 ½	144-154	5 11/16 - 6 ¼	24 13/16	20 7/8	11 13/16	21 5/8	7 5/16	10 13/16	5 7/8	57 ½	25 3/16	10 ¼	3177
OSS 170 P	2756	166-178	6 ¾ - 7	155-166	6 ¼ - 6 ¾	26 ¾	22 7/16	12 3/16	22 7/16	7 13/16	11 5/16	5 7/8	61 7/16	26	11	3560
OSS 175 P	3086	180-191	7 ¼ - 7 ½	167-179	6 9/16 - 7 1/16	28 9/16	23 3/8	12 13/16	23 3/8	8 3/8	12 3/16	6 1/8	64 15/16	27 1/8	11 13/16	4204
OSS 180 P	3527	192-204	7 ¾ - 8	180-191	7 ¼ - 7 ½	30 ½	24 7/16	13 3/16	25 3/16	9	13	6 5/16	68 ½	28 3/8	12 5/8	4936

MBL = Minimum Breaking Load
 The standard finish of our sockets is blue. Hot dipped galvanized is also available. Socket range OSS 196 until OSS 100 is delivered with galvanized finish, other finishes are available upon request. All sockets are provided with an EN 10204-2.1 declaration of conformity, EN 10204-3.1 material certificate and can be provided with a 2006/42/EC declaration where applicable.

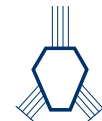

ROPEBLOCK

OPEN SPELTER SOCKETS WITH BOLT AND NUT QUENCHED AND TEMPERED CAST STEEL

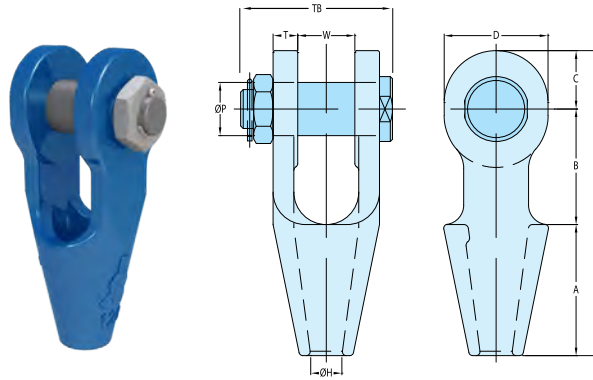

MODEL NR.	MBL	FOR WIRE Ø		STRAND Ø		DIMENSIONS (INCH)										WEIGHT (LBS)
		MM	INCH	MM	INCH	A	B	C	D	Ø H	Ø P	T	TL	TB	W	
OSS 196 B	9	6-7	¼	-	-	1 15/16	1 1/16	¾	1 1/16	¾	5/8	¾	4 5/16	2 7/16	¾	1.1
OSS 197 B	13	8-10	⅜	-	-	2 ¼	1 ¾	7/8	1 5/8	½	1 3/16	7/16	4 7/8	2 15/16	1 3/16	1.7
OSS 198 B	22	11-13	7/16 - ½	-	-	2 ½	2	1 1/16	1 1/16	9/16	1	7/16	5 9/16	3 ½	1	2.4
OSS 199 B	28	14-16	9/16 - 5/8	13	½	3	2 ½	1 ¼	2 5/16	1 1/16	1 3/16	9/16	6 ¾	3 ¾	1 ¼	4.2
OSS 100 B	44	18-19	¾	14-16	9/16 - 5/8	3 ½	3	1 1/16	2 ¾	7/8	1 3/8	5/8	8 1/16	4 3/16	1 ½	7
OSS 104 B	61	20-22	7/8	18-19	¾	4	3 ½	1 ¾	3 ½	1	1 5/8	¾	9 ¼	4 13/16	1 ¾	10
OSS 108 B	83	23-26	1	20-22	7/8	4 ½	4	2 3/8	4 ½	1 1/8	2	7/8	10 13/16	5 7/16	2	18
OSS 111 B	99	27-30	1 1/8	23-26	1	5	4 ½	2 9/16	4 ½	1 5/16	2 ¼	1	12 1/16	6 5/16	2 ¼	26
OSS 115 B	138	31-36	1 ¼ - 1 3/8	27-28	1 1/16 - 1 1/8	5 ½	5	2 13/16	4 15/16	1 1/16	2 ½	1 1/8	13 5/16	6 ½	2 ½	35
OSS 118 B	165	37-39	1 ½	30-32	1 3/16 - 1 ¼	6	6 3/8	3 ½	5 9/16	1 11/16	2 ¾	1 3/16	15 ½	7 13/16	3	50
OSS 120 B	187	40-42	1 5/8	33-35	1 5/16 - 1 3/8	6 ½	6 ½	3 7/16	6 ½	1 13/16	3	1 5/16	16 7/16	8 ¼	3	62
OSS 125 B	248	43-48	1 ¾ - 1 7/8	36-40	1 7/16 - 1 5/8	7 ½	7	3 15/16	6 15/16	2 1/16	3 ½	1 9/16	18 7/16	9 5/16	3 ½	95
OSS 128 B	309	49-54	2 - 2 1/8	42-45	1 5/8 - 1 ¾	8 ½	9	4 ¼	7 5/8	2 5/16	3 ¾	1 ¾	21 ¾	10 3/8	4	136
OSS 130 B	397	55-60	2 ¼ - 2 3/8	46-48	1 13/16 - 1 7/8	9	10	4 ¾	8 ¼	2 9/16	4 ¼	2 1/16	23 ¾	11 ¾	4 7/16	199
OSS 132 B	468	61-68	2 ½ - 2 5/8	50-54	2 - 2 1/8	9 ¾	10 ¾	5 ¼	9 5/16	2 15/16	4 ¾	2 3/8	25 ¾	13	5	270
OSS 135 B	507	69-75	2 ¾ - 2 7/8	56-62	2 ¼ - 2 ½	11	11	5 7/16	9 7/16	3 3/16	5	2 7/8	27 3/8	14 1/8	5 ¼	350
OSS 138 B	617	76-80	3 - 3 1/8	64-67	2 ½ - 2 5/8	12	11 ¼	5 ¾	9 15/16	3 ½	5 ¼	3	29	14 15/16	5 ¾	419
OSS 140 B	689	81-86	3 ¼ - 3 3/8	69-76	2 ¾ - 3	13	11 ¾	6 5/16	11 7/16	3 5/8	5 ½	3 1/8	31	15 5/8	6 ¼	507
OSS 142 B	794	87-93	3 ½ - 3 5/8	78-86	3 1/16 - 3 3/8	14	12 ½	7	12 5/8	3 7/8	6	3 ¼	33 ½	16 ½	6 ¾	632
OSS 144 B	965	94-102	3 ¾ - 4	88-96	3 7/16 - 3 ¾	15	13 ½	7 ½	13 ¾	4 ¼	7	3 ½	36	17 ¾	7 ½	831
OSS 146 B	1323	108-115	4 ¼ - 4 ½	98-110	3 7/8 - 4 5/16	17 11/16	18 7/8	8 7/16	15 ¾	5 1/16	7 11/16	3 15/16	45 1/16	19 15/16	8 1/16	1207
OSS 150 B	1543	120-130	4 ¾ - 5	112-124	4 7/16 - 4 7/8	19 11/16	19 11/16	9 13/16	17 11/16	5 13/16	8 11/16	4 9/16	49 3/16	21 ½	8 7/8	1688
OSS 155 B	1764	135-140	5 ¼ - 5 ½	125-132	4 15/16 - 5 3/16	21 ¼	19 9/16	10 3/8	18 7/8	6 1/16	9 7/16	5 ½	51 3/16	24 ½	9 1/16	2383
OSS 160 B	2205	142-153	5 ¾ - 6	133-143	5 ¼ - 5 5/8	23 1/16	19 7/8	10 13/16	19 11/16	6 ¾	10 1/16	5 ½	53 ¾	25 13/16	9 13/16	2646
OSS 165 B	2447	154-165	6 ¼ - 6 ½	144-154	5 11/16 - 6 ¼	24 13/16	20 7/8	11 13/16	21 5/8	7 5/16	10 13/16	5 7/8	57 ½	26 15/16	10 ¼	3250
OSS 170 B	2756	166-178	6 ¾ - 7	155-166	6 ¼ - 6 ¾	26 ¾	22 7/16	12 3/16	22 7/16	7 13/16	11 5/8	5 7/8	61 7/16	28 1/8	11	3649
OSS 175 B	3086	180-191	7 ¼ - 7 ½	167-179	6 9/16 - 7 1/16	28 9/16	23 5/8	12 13/16	23 5/8	8 3/8	12 3/16	6 1/8	64 15/16	29 ½	11 13/16	4312
OSS 180 B	3527	192-204	7 ¾ - 8	180-191	7 ¼ - 7 ½	30 ½	24 7/16	13 9/16	25 3/16	9	13	6 5/16	68 ½	31 1/8	12 5/8	5077

MBL = Minimum Breaking Load

The standard finish of our sockets is blue. Hot dipped galvanized is also available. Socket range OSS 196 until OSS 100 is delivered with galvanized finish, other finishes are available upon request. All sockets are provided with an EN 10204-2.1 declaration of conformity, EN 10204-3.1 material certificate and can be provided with a 2006/42/EC declaration where applicable.

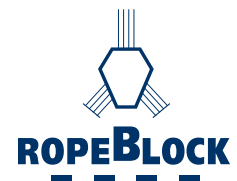

CLOSED SPELTER SOCKETS QUENCHED AND TEMPERED CAST STEEL

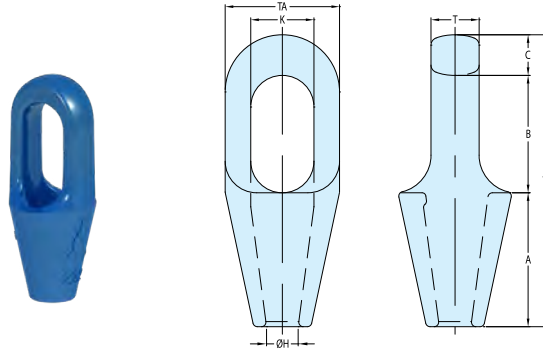

MODEL NR.	MBL (USTONS)	FOR WIRE Ø		STRAND Ø		DIMENSIONS (INCH)								WEIGHT (LBS)
		MM	INCH	MM	INCH	A	B	C	Ø H	K	T	TA	TL	
CSS 296	9	6-7	¼	-	-	1 1/16	1 1/16	7/16	3/8	7/8	½	1 1/16	4	1
CSS 297	13	8-10	3/8	-	-	2 ¼	1 7/8	9/16	½	1	1 1/16	1 1/16	4 1/16	1
CSS 298	22	11-13	7/16 - ½	-	-	2 ½	2 5/16	1 1/16	9/16	1 3/16	7/8	2	5 ½	2
CSS 299	28	14-16	5/16 - 5/8	13	½	3	2 9/16	1 3/16	1 1/16	1 7/16	1	2 5/8	6 3/8	3
CSS 200	44	18-19	¾	14-16	5/16 - 5/8	3 ½	3 1/16	1 1/16	7/8	1 5/8	1 ¼	3	7 5/8	5
CSS 201	61	20-22	7/8	18-19	¾	4	3 9/16	1 5/16	1	1 7/8	1 ½	3 5/8	8 13/16	8
CSS 204	83	23-26	1	20-22	7/8	4 ½	4 1/16	1 7/16	1 1/8	2 ¼	1 ¾	4 1/8	9 15/16	12
CSS 207	99	27-30	1 1/16	23-26	1	5	4 9/16	1 9/16	1 5/16	2 ½	2	4 ½	11 1/8	16
CSS 212	138	31-36	1 ¼ - 1 3/8	27-28	1 1/16 - 1 1/8	5 ½	5 1/8	1 1/16	1 9/16	2 ¾	2 ¼	4 15/16	12 5/16	22
CSS 215	165	37-39	1 ½	30-32	1 3/16 - 1 ¼	6	6 1/8	2	1 1/16	3 3/8	2 ½	5 3/8	14 1/8	29
CSS 217	187	40-42	1 5/8	33-35	1 5/16 - 1 3/8	6 ½	6 3/4	2 1/8	1 13/16	3 ¼	2 ¾	5 ¾	15 3/8	37
CSS 219	248	43-48	1 ¾ - 1 7/8	36-40	1 7/16 - 1 5/8	7 ½	7 13/16	2 3/16	2 1/16	3 1/16	3	6 ¾	17 7/16	56
CSS 222	309	49-54	2 - 2 1/16	42-45	1 5/8 - 1 ¾	8 ½	8 13/16	2 7/16	2 5/16	3 1/16	3 ¼	7 5/8	19 ¾	81
CSS 224	397	55-60	2 ¼ - 2 3/8	46-48	1 13/16 - 1 7/8	9	9 3/4	2 7/8	2 9/16	4 1/16	3 5/8	8 ½	21 1/16	111
CSS 226	468	61-68	2 ½ - 2 5/8	50-54	2 - 2 1/8	9 ¾	10 5/8	3 1/8	2 15/16	5 ½	4	9 ½	23 ½	144
CSS 227	507	69-75	2 ¾ - 2 7/8	56-62	2 ¼ - 2 ½	11	11 ¼	3 1/8	3 1/8	6 ¼	4 7/8	10 ¾	25 5/8	201
CSS 228	617	76-80	3 - 3 1/16	64-67	2 ½ - 2 5/8	12 3/8	11 ¾	3 ¼	3 ½	6 ¾	5 ¼	11 ½	27 3/8	257
CSS 229	689	81-86	3 ¼ - 3 3/8	69-76	2 ¾ - 3	13	12 ¼	4	3 5/8	7 ¼	5 ¾	12 ¼	29 ¼	274
CSS 230	794	87-93	3 ½ - 3 5/8	78-86	3 1/16 - 3 3/8	14	13	4	3 7/8	7 ¾	6 ¼	13	31	388
CSS 231	965	94-102	3 ¾ - 4	88-96	3 7/16 - 3 ¾	15	14	4 ¼	4 ¼	8 ½	7	14 ¼	33 ¼	502
CSS 233	1323	108-115	4 ¼ - 4 ½	98-110	3 7/8 - 4 5/16	17 1/16	16 ¾	4 15/16	5 1/8	9 ¼	7 ½	15 15/16	39 3/8	712
CSS 240	1543	120-130	4 ¾ - 5	112-124	4 7/16 - 4 7/8	19 1/16	20 1/16	4 15/16	5 13/16	10 ¼	7 7/8	17 1/16	45 ¼	986
CSS 245	1764	135-140	5 ¼ - 5 ½	125-132	4 15/16 - 5 3/16	21 ¼	19 ½	6	6 1/8	11 ½	8 ¾	20 ½	46 5/8	1422
CSS 250	2205	142-153	5 ¾ - 6	133-143	5 ¼ - 5 5/8	23 1/16	20 ¾	6 1/16	6 ¾	12	9 7/16	21 ½	50 ½	1634
CSS 255	2447	154-165	6 ½ - 6 ¼	144-154	5 1/16 - 6 ¼	24 13/16	22 ¼	6 7/8	7 ¼	13	10	22 5/8	53 7/8	1896
CSS 260	2756	166-178	6 ¾ - 7	155-166	6 ¼ - 6 ¾	26 ¾	23 ¼	7	7 13/16	13	10 5/8	23 1/16	57	2172
CSS 265	3086	180-191	7 ¼ - 7 ½	167-179	6 5/16 - 7 1/16	28 5/16	24 ½	7 ½	8 3/8	13 ¾	11 ½	24 5/8	60 1/16	2608
CSS 270	3527	192-204	7 ¾ - 8	180-191	7 ¼ - 7 ½	30 ½	25 5/16	8 ¼	9	15 ½	12	27 ¼	64 ¼	3278

MBL = Minimum Breaking Load
 The standard finish of our sockets is blue. Hot dipped galvanized is also available. Socket range CSS 296 until CSS 201 is delivered with galvanized finish, other finishes are available upon request. All sockets are provided with an EN 10204-2.1 declaration of conformity, EN 10204-3.1 material certificate and can be provided with a 2006/42/EC declaration where applicable.



SHORT BOW SOCKETS

QUENCHED AND TEMPERED CAST STEEL

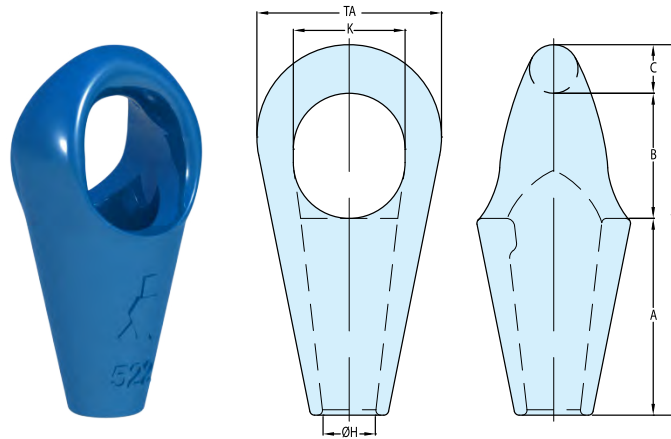

MODEL NR.	MBL (USTONS)	FOR WIRE Ø		DIMENSIONS (INCH)							WEIGHT (LBS)
		MM	INCH	A	B	C	Ø H	K	TA	TL	
SBS 512	154	31-36	1 ¼ - 1 ¾	5 ⅞	3 ¼	1 ½	1 ½	2 15/16	5 5/16	10 5/16	15
SBS 517	176	37-42	1 ½ - 1 ⅝	6 ¾	4 1/16	1 ½	1 ¾	3 5/8	6	12	22
SBS 519	220	43-48	1 ¾ - 1 ⅞	7 ¾	4 ¾	1 7/8	2	4 7/16	7	14	34
SBS 522	276	49-54	2 - 2 ½	8 1/16	5 5/16	2 ½	2 ¼	4 ¾	7 7/8	15 3/8	46
SBS 524	353	55-60	2 ¼ - 2 ⅝	9 1/16	5 13/16	2 7/16	2 ½	5 5/16	8 1 1/16	17 5/16	62
SBS 526	441	61-68	2 ½ - 2 ⅝	10 ½	6 ½	2 1 1/16	2 15/16	5 7/8	9 13/16	19 5/8	96
SBS 527	551	69-75	2 ¾ - 2 7/8	11 1/16	7	2 15/16	3 1/8	6 7/16	10 13/16	21 ¼	118
SBS 528	661	76-80	3 - 3 ½	12 3/8	7 1 1/16	3	3 ½	6 7/8	11 5/8	23 1/16	155
SBS 529	772	81-86	3 ¼ - 3 ⅝	12 7/8	8 ½	3 ¼	3 5/8	7 5/8	12 5/8	24 5/8	179
SBS 530	882	87-93	3 ½ - 3 ⅝	14 1/8	8 1 1/16	3 5/8	3 7/8	7 15/16	13 ¾	26 3/8	246
SBS 531	992	94-102	3 ¾ - 4	14 3/8	9 ¼	3 15/16	4 ¼	8 7/16	14 ¾	27 5/16	287
SBS 533	1102	108-115	4 ¼ - 4 ½	16 1/16	10 5/8	4 5/8	4 ¾	9 7/16	16 1/8	31 ½	401

MBL = Minimum Breaking Load

The standard finish of our sockets is blue. Hot dipped galvanized is also available.

All sockets are provided with an EN 10204-2.1 declaration of conformity, EN 10204-3.1 material certificate and can be provided with a 2006/42/EC declaration where applicable.

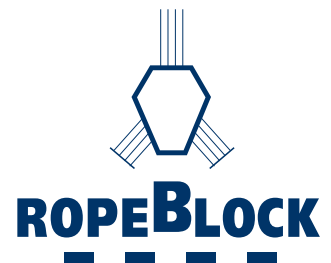

FAST CONNECTOR SOCKETS WITH PIN QUENCHED AND TEMPERED CAST STEEL

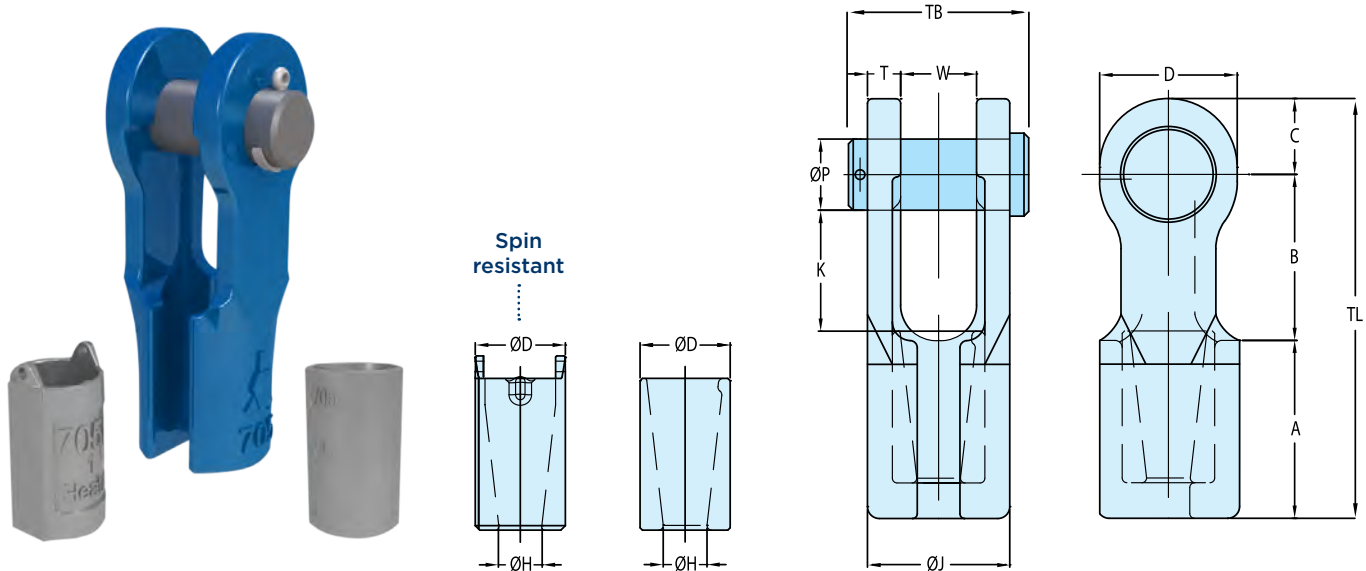

MODEL NR.	REEVING AID	MBL (USTONS)	FOR WIRE Ø		DIMENSIONS (INCH)													WEIGHT (LBS)
			MM	INCH	A	B	C	Ø H	Ø P	T	W	D	Ø D	Ø J	K	TB	TL	
FCS 701 P	-	22	11-13	7/16 - 1/2	2 1/16	2 3/8	1 1/16	9/16	1	1/2	1	1 1/16	1 5/16	1 1/16	1 13/16	2 1/8	5 7/8	4
FCS 702 P	-	28	13-16	1/2 - 5/8	2 13/16	3 1/16	1 1/4	1 1/16	1 3/16	9/16	1 1/4	2 5/16	1 1/2	2 3/8	2 5/16	3 3/8	7 3/16	6
FCS 703 P	-	44	16-19	5/8 - 3/4	3 3/8	3 11/16	1 1/16	1 3/16	1 3/8	5/8	1 3/4	2 3/4	1 11/16	2 3/4	2 11/16	3 3/4	8 9/16	10
FCS 704 P	-	61	20-22	3/4	4	4 3/16	1 3/4	1 5/16	1 5/8	3/4	1 3/4	3 1/8	1 15/16	3 1/4	3 3/16	4 3/16	9 15/16	14
FCS 705 P	-	83	23-26	1	4 1/2	4 13/16	2 3/8	1 1/8	2	7/8	2	4 1/8	2 3/8	3 3/4	3 3/16	5 1/16	11 5/8	24
FCS 706 P	-	99	27-29	1 1/8	5 1/2	6	2 9/16	1 1/4	2 1/4	1	2 1/4	4 1/2	2 3/4	4 3/16	4 9/16	5 5/16	14 1/16	35
FCS 705 P.SR	T 705	83	23-26	1	4 1/2	4 13/16	2 3/8	1 1/8	2	7/8	2	4 1/8	2 3/8	3 3/4	3 3/16	5 1/16	11 5/8	24
FCS 706 P.SR	T 706	99	27-29	1 1/8	5 1/2	6	2 9/16	1 1/4	2 1/4	1	2 1/4	4 1/2	2 3/4	4 3/16	4 9/16	5 5/16	14 1/16	35
FCS 707 P.SR	T 706	138	30-32	1 1/4	5 7/8	6 1/2	2 7/8	1 7/16	2 1/2	1 1/8	2 1/2	4 1/16	3 1/8	4 1/16	4 3/4	6 1/8	15 1/16	40
FCS 708 P.SR	T 706	138	33-36	1 3/8	6 5/16	6 3/4	2 7/8	1 1/16	2 1/2	1 1/8	2 11/16	4 1/16	3 3/8	4 1/16	5 1/8	6 5/16	15 7/8	51
FCS 709 P.SR	T 709	165	37-39	1 1/2	6 15/16	7 3/8	3 1/8	1 5/16	2 3/4	1 3/16	3	5 5/16	3 9/16	5 3/8	5 5/16	6 15/16	17 7/16	64
FCS 710 P.SR	T 709	187	40-42	1 5/8	7 3/8	7 13/16	3 7/16	1 3/4	3	1 5/16	3	6 1/8	3 3/4	5 5/16	5 7/8	7 3/8	18 11/16	79
FCS 711 P.SR	T 711	248	43-48	1 3/4 - 1 7/8	8 1/4	9 1/8	3 15/16	2 1/16	3 1/2	1 1/16	3 1/2	6 1/16	4 5/16	6 9/16	6 7/8	8 7/16	21 3/16	128



REEVING TOOL (OPTIONAL)

MBL = Minimum Breaking Load

The standard finish of our sockets is blue. Hot dipped galvanized is also available. All sockets are provided with an EN 10204-2.1 declaration of conformity, EN 10204-3.1 material certificate and can be provided with a 2006/42/EC declaration where applicable.

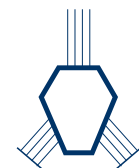

ROPEBLOCK

FAST CONNECTOR SOCKETS WITH BOLT AND NUT QUENCHED AND TEMPERED CAST STEEL

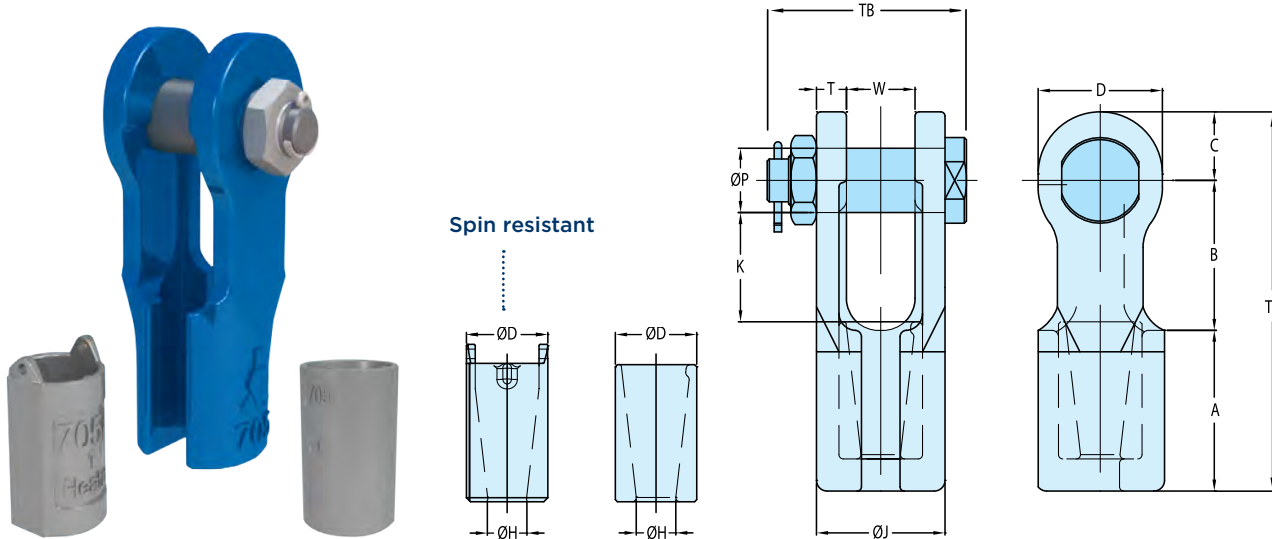

MODEL NR.	REEVING AID	MBL (USTONS)	FOR WIRE Ø		DIMENSIONS (INCH)													WEIGHT (LBS)
			MM	INCH	A	B	C	Ø H	Ø P	T	W	D	Ø D	Ø J	K	TB	TL	
FCS 701 B	-	22	11-13	7/16 - 1/2	2 7/16	2 3/8	1 1/16	9/16	1	1/2	1	1 15/16	1 5/16	1 15/16	1 13/16	3 1/8	5 7/8	4
FCS 702 B	-	28	13-16	1/2 - 5/8	2 13/16	3 1/8	1 1/4	1 1/16	1 3/16	9/16	1 1/4	2 5/16	1 1/2	2 3/8	2 5/16	3 3/4	7 3/16	6
FCS 703 B	-	44	16-19	5/8 - 3/4	3 3/8	3 11/16	1 9/16	1 3/16	1 3/8	5/8	1 3/4	2 3/4	1 12/16	2 3/4	2 11/16	4 3/16	8 9/16	10
FCS 704 B	-	61	20-22	7/8	4	4 3/16	1 3/4	1 5/16	1 5/8	3/4	1 3/4	3 1/8	1 15/16	3 1/4	3 3/16	4 13/16	9 15/16	14
FCS 705 B	-	83	23-26	1	4 1/2	4 13/16	2 3/8	1 1/8	2	7/8	2	4 1/8	2 3/8	3 3/4	3 9/16	5 7/16	11 5/8	24
FCS 706 B	-	99	27-29	1 1/8	5 1/2	6	2 9/16	1 1/4	2 1/4	1	2 1/4	4 1/2	2 3/4	4 3/16	4 9/16	6 5/16	14 1/16	35
FCS 705 B.SR	T 705	83	23-26	1	4 1/2	4 13/16	2 3/8	1 1/8	2	7/8	2	4 1/8	2 3/8	3 3/4	3 9/16	5 7/16	11 5/8	24
FCS 706 B.SR	T 706	99	27-29	1 1/8	5 1/2	6	2 9/16	1 1/4	2 1/4	1	2 1/4	4 1/2	2 3/4	4 3/16	4 9/16	6 5/16	14 1/16	35
FCS 707 B.SR	T 706	138	30-32	1 1/4	5 7/8	6 1/2	2 7/8	1 7/16	2 1/2	1 1/8	2 1/2	4 15/16	3 1/8	4 11/16	4 3/4	6 1/2	15 1/16	40
FCS 708 B.SR	T 706	138	33-36	1 3/8	6 5/16	6 3/4	2 7/8	1 9/16	2 1/2	1 1/8	2 11/16	4 15/16	3 3/8	4 15/16	5 1/8	7 5/16	15 7/8	51
FCS 709 B.SR	T 709	165	37-39	1 1/2	6 15/16	7 3/8	3 1/8	1 5/8	2 3/4	1 3/16	3	5 9/16	3 9/16	5 3/8	5 9/16	7 15/16	17 7/16	64
FCS 710 B.SR	T 709	187	40-42	1 5/8	7 3/8	7 13/16	3 7/16	1 3/4	3	1 5/16	3	6 1/8	3 3/4	5 9/16	5 7/8	8 1/4	18 11/16	79
FCS 711 B.SR	T 711	248	43-48	1 3/4 - 1 7/8	8 1/4	9 1/8	3 15/16	2 1/16	3 1/2	1 9/16	3 1/2	6 15/16	4 5/16	6 9/16	6 7/8	9 5/16	21 5/16	128



REEVING TOOL (OPTIONAL)

MBL = Minimum Breaking Load

The standard finish of our sockets is blue. Hot dipped galvanized is also available. All sockets are provided with an EN 10204-2.1 declaration of conformity, EN 10204-3.1 material certificate and can be provided with a 2006/42/EC declaration where applicable.

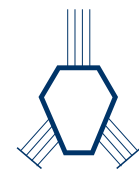

ROPEBLOCK

SUPER REEVE CONNECTOR SOCKETS WITH PIN QUENCHED AND TEMPERED CAST STEEL

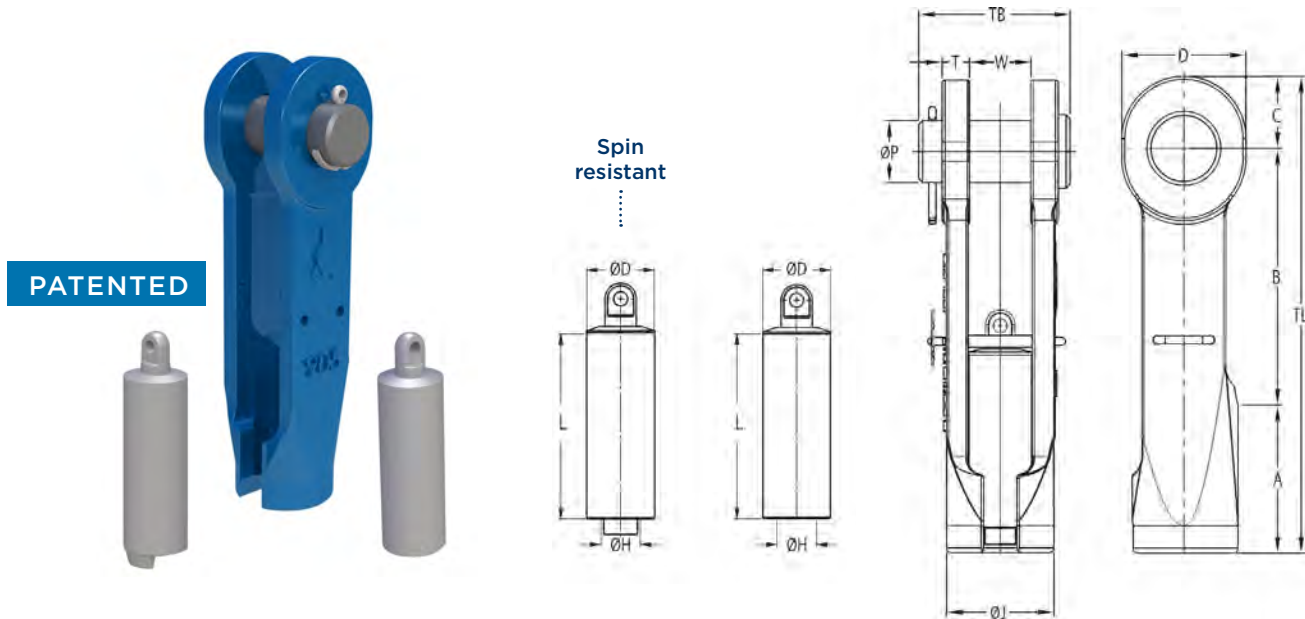

MODEL NR.	MBL (USTONS)	FOR WIRE Ø		DIMENSIONS (INCH)													WEIGHT (LBS)
		MM	INCH	A	B	C	Ø H	Ø P	T	W	D	Ø D	Ø J	L	TB	TL	
SCS 901 P	22	11-13	7/16 - 1/2	-	-	-	-	-	-	-	-	-	-	-	-	-	-
SCS 902 P	28	13-16	1/2 - 5/8	3 3/8	5 1/4	1 1/4	3/4	1 3/16	9/16	1 1/4	2 5/16	1 1/4	2 3/16	3 7/8	3 3/8	9 13/16	7
SCS 903 P	44	16-19	5/8 - 3/4	3 9/16	6 5/16	1 9/16	7/8	1 3/8	5/8	1 1/2	2 3/4	1 9/16	2 9/16	4 1/2	3 3/4	11 7/16	11
SCS 904 P	61	20-22	7/8	4 3/16	7 1/4	1 3/4	1	1 5/8	3/4	1 3/4	3 1/8	1 3/4	3 1/16	5 1/8	4 5/16	13 1/4	17
SCS 905 P	83	23-26	1	4 1/2	8 9/16	2 3/8	1 3/16	1 15/16	7/8	2	4 1/8	2 1/16	3 7/16	5 9/16	5 1/16	15 3/16	26
SCS 906 P	99	27-29	1 1/8	5 1/2	8 7/16	2 9/16	1 5/16	2 1/4	1	2 1/4	4 1/2	2 5/16	3 3/4	6 1/4	5 9/16	16 9/16	35
SCS 907 P	138	30-32	1 1/4	5 7/8	10 1/4	2 7/8	1 7/16	2 1/2	1 1/8	2 1/2	4 15/16	2 1/2	4 9/16	6 15/16	6 1/8	19	51
SCS 908 P	138	33-36	1 3/8	6 11/16	10 1/4	2 7/8	1 9/16	2 1/2	1 1/8	2 11/16	4 15/16	2 11/16	4 1/2	7 3/4	6 5/16	19 13/16	55
SCS 902 P.SR	28	13-16	1/2 - 5/8	3 3/8	5 1/4	1 1/4	3/4	1 3/16	9/16	1 1/4	2 5/16	1 1/4	2 3/16	3 7/8	3 3/8	9 13/16	7
SCS 903 P.SR	44	16-19	5/8 - 3/4	3 9/16	6 5/16	1 9/16	7/8	1 3/8	5/8	1 1/2	2 3/4	1 9/16	2 9/16	4 1/2	3 3/4	11 7/16	11
SCS 904 P.SR	61	20-22	7/8	4 3/16	7 1/4	1 3/4	1	1 5/8	3/4	1 3/4	3 1/8	1 3/4	3 1/16	5 1/8	4 5/16	13 1/4	17
SCS 905 P.SR	83	23-26	1	4 1/2	8 9/16	2 3/8	1 3/16	1 15/16	7/8	2	4 1/8	2 1/16	3 7/16	5 9/16	5 1/16	15 3/16	26
SCS 906 P.SR	99	27-29	1 1/8	5 1/2	8 7/16	2 9/16	1 5/16	2 1/4	1	2 1/4	4 1/2	2 5/16	3 3/4	6 1/4	5 9/16	16 9/16	35
SCS 907 P.SR	138	30-32	1 1/4	5 7/8	10 1/4	2 7/8	1 7/16	2 1/2	1 1/8	2 1/2	4 15/16	2 1/2	4 9/16	6 15/16	6 1/8	19	51
SCS 908 P.SR	138	33-36	1 3/8	6 11/16	10 1/4	2 7/8	1 9/16	2 1/2	1 1/8	2 11/16	4 15/16	2 11/16	4 1/2	7 3/4	6 5/16	19 13/16	55
SCS 909 P.SR	165	37-39	1 1/2	-	-	-	-	-	-	-	-	-	-	-	-	-	-
SCS 910 P.SR	187	40-42	1 5/8	-	-	-	-	-	-	-	-	-	-	-	-	-	-
SCS 911 P.SR	248	43-48	1 3/4 - 1 7/8	-	-	-	-	-	-	-	-	-	-	-	-	-	-
SCS 912 P.SR	309	49-54	2 - 2 1/8	8 7/8	14 11/16	4 1/4	2 3/8	3 3/4	1 3/4	4	7 5/8	4 1/8	7 9/16	11	9 5/8	27 13/16	205

MBL = Minimum Breaking Load

The standard finish of our sockets is blue. Hot dipped galvanized is also available. All sockets are provided with an EN 10204-2.1 declaration of conformity, EN 10204-3.1 material certificate and can be provided with a 2006/42/EC declaration where applicable.



ROPEBLOCK

SUPER REEVE CONNECTOR SOCKETS WITH BOLT AND NUT QUENCHED AND TEMPERED CAST STEEL

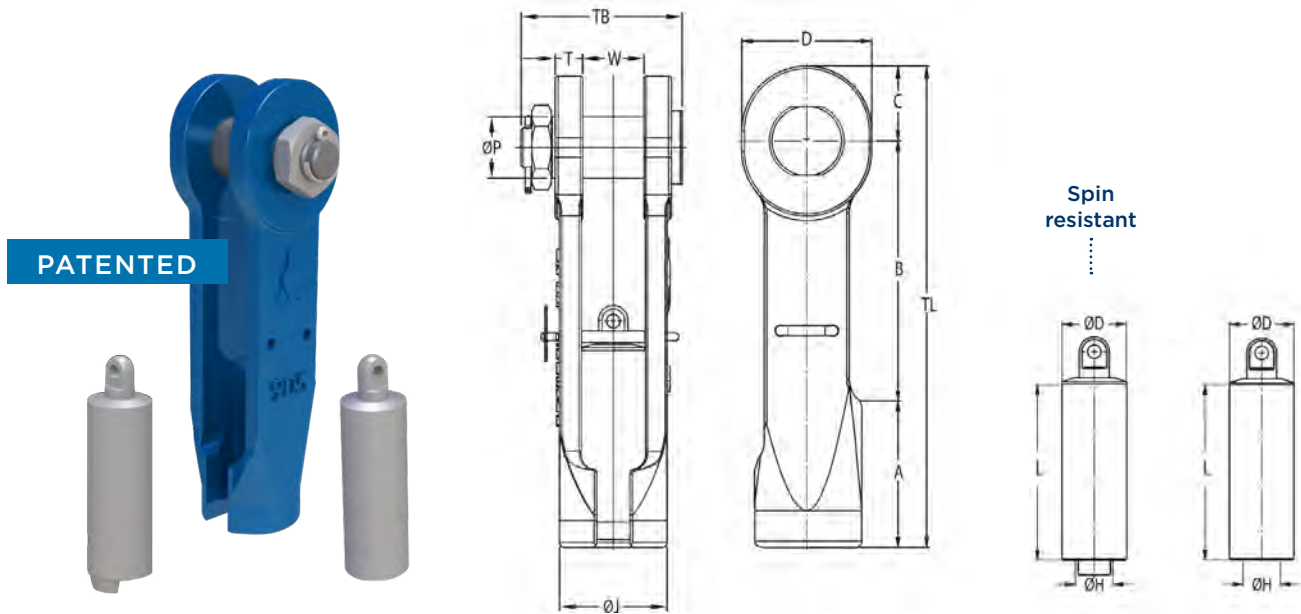

MODEL NR.	MBL (USTONS)	FOR WIRE Ø		DIMENSIONS (INCH)													WEIGHT (LBS)
		MM	INCH	A	B	C	Ø H	Ø P	T	W	D	Ø D	Ø J	L	TB	TL	
SCS 901 B	22	11-13	7/16 - 1/2	-	-	-	-	-	-	-	-	-	-	-	-	-	-
SCS 902 B	28	13-16	1/2 - 5/8	3 3/8	5 1/4	1 1/4	3/4	1 3/16	9/16	1 1/4	2 5/16	1 1/4	2 3/16	3 7/8	3 3/4	9 13/16	7
SCS 903 B	44	16-19	5/8 - 3/4	3 9/16	6 5/16	1 9/16	7/8	1 3/8	5/8	1 1/2	2 3/4	1 9/16	2 9/16	4 1/2	4 3/16	11 7/16	11
SCS 904 B	61	20-22	7/8	4 3/16	7 1/4	1 3/4	1	1 5/8	3/4	1 3/4	3 1/8	1 3/4	3 1/16	5 1/8	4 13/16	13 1/4	17
SCS 905 B	83	23-26	1	4 1/2	8 5/16	2 7/8	1 3/16	1 15/16	7/8	2	4 1/8	2 1/16	3 7/16	5 5/16	5 7/16	15 3/16	26
SCS 906 B	99	27-29	1 1/8	5 1/2	8 7/16	2 9/16	1 5/16	2 1/4	1	2 1/4	4 1/2	2 5/16	3 3/4	6 1/4	6 5/16	16 9/16	35
SCS 907 B	138	30-32	1 1/4	5 7/8	10 1/4	2 7/8	1 7/16	2 1/2	1 1/8	2 1/2	4 15/16	2 1/2	4 5/16	6 15/16	6 1/2	19	51
SCS 908 B	138	33-36	1 3/8	6 11/16	10 1/4	2 7/8	1 9/16	2 1/2	1 1/8	2 11/16	4 15/16	2 11/16	4 1/2	7 3/4	7 5/16	19 13/16	55
SCS 902 B.SR	28	13-16	1/2 - 5/8	3 3/8	5 1/4	1 1/4	3/4	1 3/16	9/16	1 1/4	2 5/16	1 1/4	2 3/16	3 7/8	3 3/4	9 13/16	7
SCS 903 B.SR	44	16-19	5/8 - 3/4	3 9/16	6 5/16	1 9/16	7/8	1 3/8	5/8	1 1/2	2 3/4	1 9/16	2 9/16	4 1/2	4 3/16	11 7/16	11
SCS 904 B.SR	61	20-22	7/8	4 3/16	7 1/4	1 3/4	1	1 5/8	3/4	1 3/4	3 1/8	1 3/4	3 1/16	5 1/8	4 13/16	13 1/4	17
SCS 905 B.SR	83	23-26	1	4 1/2	8 5/16	2 7/8	1 3/16	1 15/16	7/8	2	4 1/8	2 1/16	3 7/16	5 5/16	5 7/16	15 3/16	26
SCS 906 B.SR	99	27-29	1 1/8	5 1/2	8 7/16	2 9/16	1 5/16	2 1/4	1	2 1/4	4 1/2	2 5/16	3 3/4	6 1/4	6 5/16	16 9/16	35
SCS 907 B.SR	138	30-32	1 1/4	5 7/8	10 1/4	2 7/8	1 7/16	2 1/2	1 1/8	2 1/2	4 15/16	2 1/2	4 5/16	6 15/16	6 1/2	19	51
SCS 908 B.SR	138	33-36	1 3/8	6 11/16	10 1/4	2 7/8	1 9/16	2 1/2	1 1/8	2 11/16	4 15/16	2 11/16	4 1/2	7 3/4	7 5/16	19 13/16	55
SCS 909 B.SR	165	37-39	1 1/2	-	-	-	-	-	-	-	-	-	-	-	-	-	-
SCS 910 B.SR	187	40-42	1 5/8	-	-	-	-	-	-	-	-	-	-	-	-	-	-
SCS 911 B.SR	248	43-48	1 3/4 - 1 7/8	-	-	-	-	-	-	-	-	-	-	-	-	-	-
SCS 912 B.SR	309	49-54	2 - 2 1/8	8 7/8	14 11/16	4 1/4	2 3/8	3 3/4	1 3/4	4	7 5/8	4 1/8	7 5/16	11	10 3/8	27 13/16	205

MBL = Minimum Breaking Load
The standard finish of our sockets is blue. Hot dipped galvanized is also available. All sockets are provided with an EN 10204-2.1 declaration of conformity, EN 10204-3.1 material certificate and can be provided with a 2006/42/EC declaration where applicable.

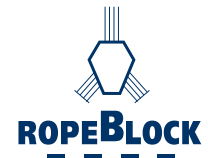

SUPER REEVE CONNECTOR SWIVEL SOCKETS WITH PIN QUENCHED AND TEMPERED CAST STEEL

PATENTED

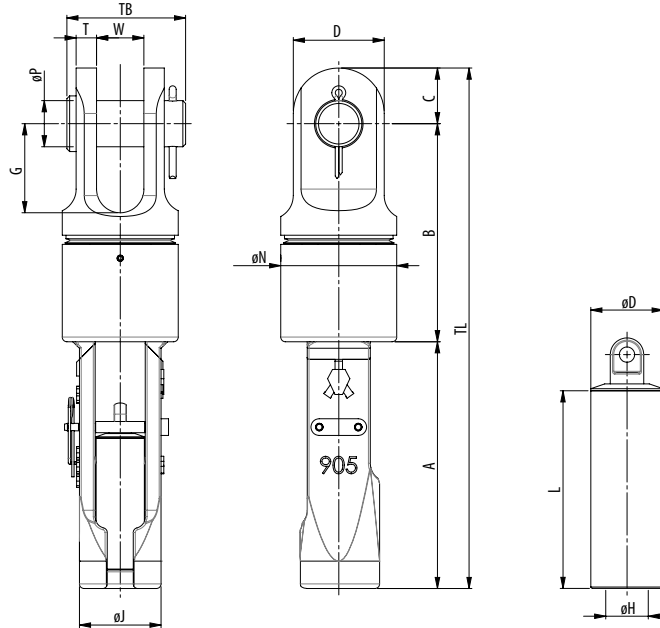

Model No.	MBL (UStons)	for wire ø		Dimensions (inch)														Weight (lbs)	
		(mm)	(inch)	A	B	C	øH	øP	T	W	G	D	øD	øJ	øN	L	TB		TL
SCS-SW 902 P	28	13-16	½ - ⅝	7.17	6.18	1.26	0.75	1.18	0.55	1.26	2.36	2.28	1.26	2.20	2.99	3.86	3.35	14.61	15
SCS-SW 903 P	44	16-19	⅝ - ¾	8.19	7.32	1.57	0.87	1.38	0.63	1.50	2.76	2.76	1.57	2.56	3.66	4.49	3.74	17.09	24
SCS-SW 904 P	61	20-22	⅞	9.37	8.19	1.77	1.00	1.61	0.75	1.73	3.15	3.15	1.73	3.03	4.13	5.12	4.33	19.33	37
SCS-SW 905 P	83	23-26	1	10.47	9.25	2.36	1.20	1.97	0.87	2.01	3.78	3.86	2.05	3.46	4.92	5.59	5.04	22.09	57
SCS-SW 906 P	99	27-29	1⅛	11.42	10.31	2.56	1.34	2.24	0.98	2.24	4.21	4.25	2.28	3.78	5.31	6.26	5.59	24.29	75
SCS-SW 907 P	138	30-32	1¼	12.87	11.50	2.87	1.43	2.48	1.10	2.48	4.65	4.72	2.52	4.33	5.91	6.97	6.10	27.24	108

MBL = Minimum Breaking Load

The standard finish of our sockets is blue. Hot dipped galvanized is also available. All sockets are provided with an EN 10204-2.1 declaration of conformity, EN 10204-3.1 material certificate and can be provided with a 2006/42/EC declaration where applicable.



ROPEBLOCK

SUPER REEVE CONNECTOR SWIVEL SOCKETS WITH BOLT AND NUT

QUENCHED AND TEMPERED CAST STEEL

PATENTED

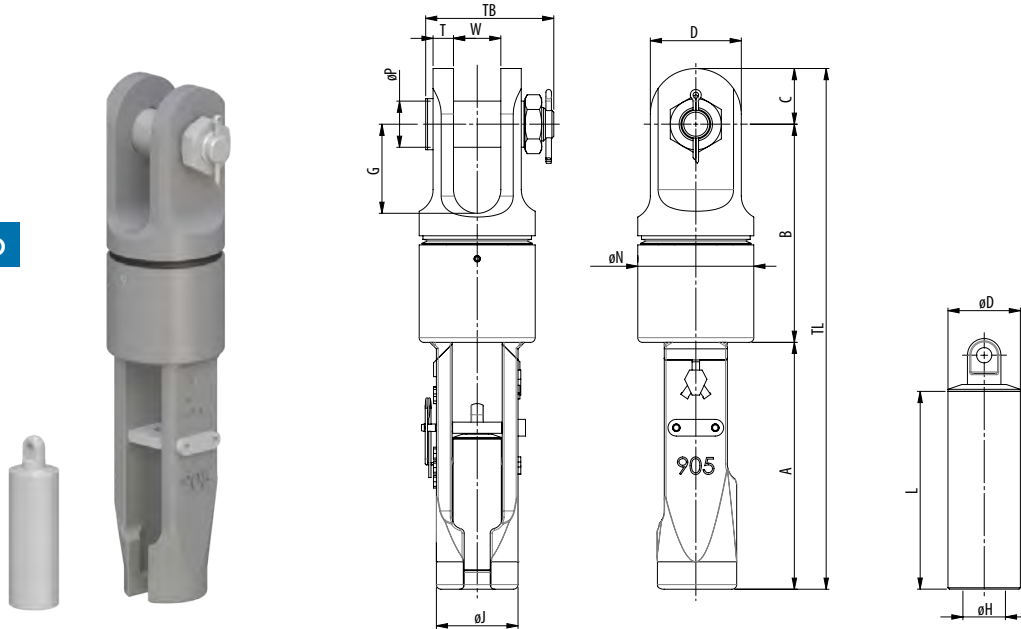

Model No.	MBL (UStons)	for wire ø		Dimensions (inch)														Weight (lbs)	
		(mm)	(inch)	A	B	C	øH	øP	T	W	G	D	øD	øJ	øN	L	TB		TL
SCS-SW 902 B	28	13-16	½ - ⅝	7.17	6.18	1.26	0.75	1.18	0.55	1.26	2.36	2.28	1.26	2.20	2.99	3.86	3.78	14.61	15
SCS-SW 903 B	44	16-19	⅝ - ¾	8.19	7.32	1.57	0.87	1.38	0.63	1.50	2.76	2.76	1.57	2.56	3.66	4.49	4.21	17.09	24
SCS-SW 904 B	61	20-22	⅞	9.37	8.19	1.77	1.00	1.61	0.75	1.73	3.15	3.15	1.73	3.03	4.13	5.12	4.84	19.33	37
SCS-SW 905 B	83	23-26	1	10.47	9.25	2.36	1.20	1.97	0.87	2.01	3.78	3.86	2.05	3.46	4.92	5.59	5.43	22.09	57
SCS-SW 906 B	99	27-29	1⅛	11.42	10.31	2.56	1.34	2.24	0.98	2.24	4.21	4.25	2.28	3.78	5.31	6.26	6.30	24.29	75
SCS-SW 907 B	138	30-32	1¼	12.87	11.50	2.87	1.43	2.48	1.10	2.48	4.65	4.72	2.52	4.33	5.91	6.97	6.50	27.24	108

MBL = Minimum Breaking Load

The standard finish of our sockets is blue. Hot dipped galvanized is also available. All sockets are provided with an EN 10204-2.1 declaration of conformity, EN 10204-3.1 material certificate and can be provided with a 2006/42/EC declaration where applicable.



OPEN WEDGE SOCKETS WITH PIN

QUENCHED AND TEMPERED CAST STEEL

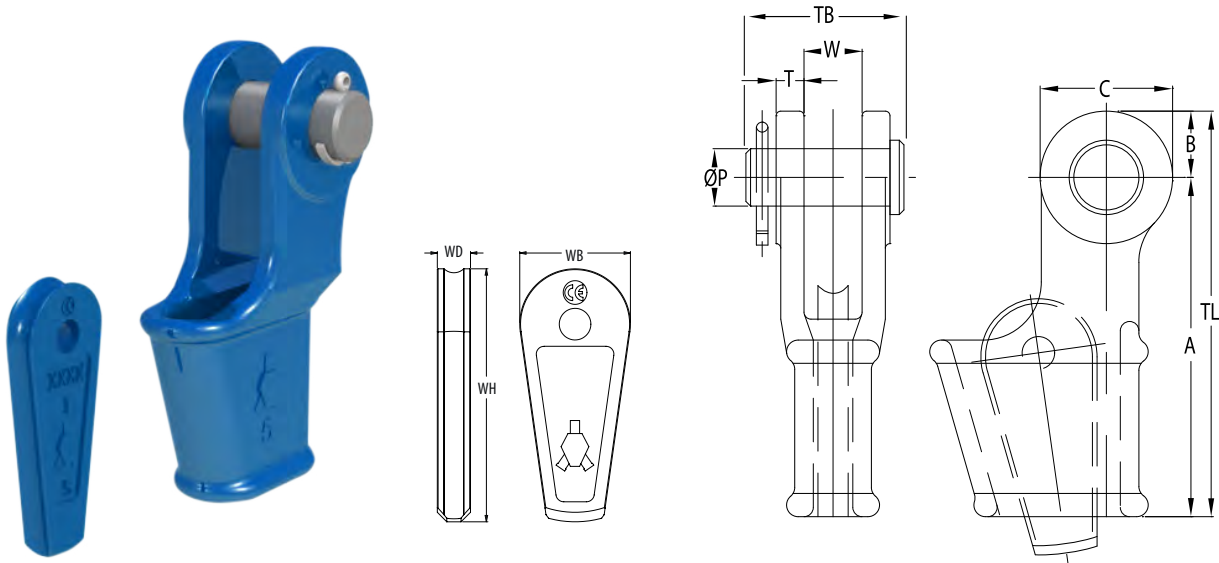

MODEL NR.	MBL (USTONS)	FOR WIRE Ø		DIMENSIONS (INCH)											WEIGHT (LBS)
		MM	INCH	A	B	C	Ø P	T	TL	TB	W	WH	WB	WD	
OWS 0.25 P	9	7-8	5/16	4 5/16	3/4	1 7/16	5/8	3/8	5 1/16	2	1 1/16	2.74	1.38	0.33	2
OWS 0.5 P	13	9-10	3/8	5 1/16	7/8	1 13/16	13/16	7/16	6 1/2	2 1/2	13/16	2.91	1.42	0.47	4
OWS 1 P	22	11-13	1/2	5 3/4	1 1/8	2 1/4	1	1/2	6 7/8	2 5/8	1	4.53	1.89	0.55	5
OWS 2 P	28	14-16	5/8	6 15/16	1 3/8	2 3/4	1 3/16	9/16	8 5/16	3 3/8	1 1/4	5.30	2.24	0.71	9
OWS 3 P	44	18-19	3/4	8 2/8	1 9/16	3 1/8	1 3/8	5/8	9 13/16	3 3/4	1 1/2	6.30	2.76	0.83	15
OWS 4 P	61	20-22	7/8	9 9/16	1 7/8	3 3/4	1 5/8	3/4	11 1/16	4 5/16	1 3/4	7.34	3.03	0.94	22
OWS 5 P	83	24-26	1	10 13/16	2 3/16	4 5/16	2	7/8	13	5 1/16	2	8.33	3.27	1.08	33
OWS 6 P	99	27-29	1 1/8	12 3/16	2 9/16	5 1/8	2 1/4	1	14 3/4	5 9/16	2 1/4	9.11	3.58	1.18	46
OWS 7 P	121	30-32	1 1/4	13 3/4	2 7/8	5 3/4	2 1/2	1 1/8	16 5/8	6 1/8	2 1/2	10.47	4.25	1.30	68
OWS 8 P	138	34-36	1 3/8	15 3/4	2 15/16	5 13/16	2 1/2	1 1/8	18 11/16	6 5/16	2 3/4	11.73	4.57	1.38	82
OWS 9 P	165	37-39	1 1/2	17 11/16	3 1/8	5 9/16	2 3/4	1 3/16	20 7/8	6 15/16	3 1/16	13.31	5.12	1.50	112
OWS 10 P	187	40-42	1 5/8	19 1/16	3 7/16	6 5/16	3	1 5/16	23 1/8	7 3/8	3	14.67	5.51	1.61	141
OWS 11 P	248	43-48	1 3/4 - 1 7/8	21 5/8	3 15/16	7 5/16	3 1/2	1 9/16	25 9/16	8 7/16	3 1/2	16.06	5.75	1.89	212
OWS 12 P	309	49-52	2	25 3/16	4 1/8	8 1/16	3 3/4	1 13/16	29 5/16	9 5/8	4	17.72	6.30	2.09	287
OWS 13 P	397	54-58	2 1/4	26	4 15/16	9 13/16	4 1/4	2 1/8	30 7/8	10 13/16	4 1/2	18.50	6.61	2.28	397
OWS 14 P	468	60-68	2 1/2	32 7/8	5 5/16	10 5/8	4 3/4	2 3/8	38 3/16	11 13/16	5	19.69	6.93	2.56	606
OWS 15 P	507	72-76	3	39 3/8	5 7/8	11 13/16	5 1/4	3	45 1/4	14	5 3/4	21.65	9.61	2.76	970
OWS 16 P	689	81-86	3 1/4 - 3 3/8	43 5/16	5 1/16	11 13/16	5 1/2	3 1/8	49 3/16	14 13/16	6 1/4	26.38	10.24	3.15	1124

MBL = Minimum Breaking Load

The standard finish of our sockets is blue. Hot dipped galvanized is also available. Socket range OWS 0.25 until OWS 0.5 is delivered with galvanized finish, other finishes are available upon request. All sockets are provided with an EN 10204-2.1 declaration of conformity, EN 10204-3.1 material certificate and can be provided with a 2006/42/EC declaration where applicable. Meets performance requirements of API 2C.

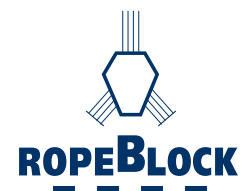

OPEN WEDGE SOCKETS WITH BOLT AND NUT QUENCHED AND TEMPERED CAST STEEL

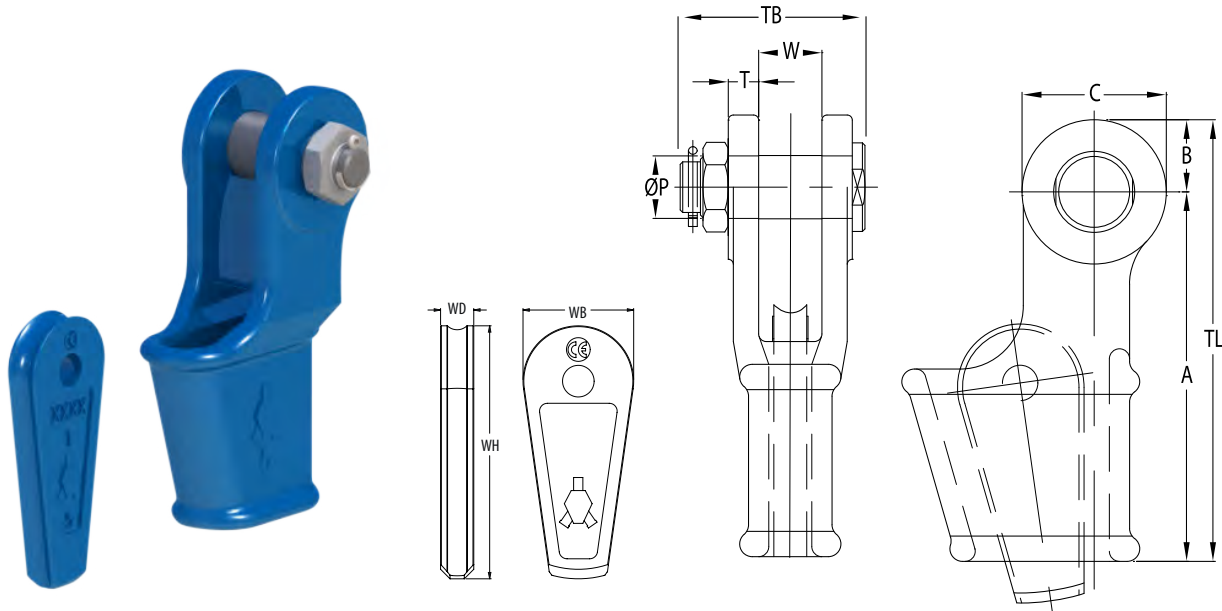

MODEL NR.	MBL (USTONS)	FOR WIRE Ø		DIMENSIONS (INCH)											WEIGHT (LBS)
		MM	INCH	A	B	C	Ø P	T	TL	TB	W	WH	WB	WD	
OWS 0.25 B	9	7-8	5/16	4.33	0.71	1.42	0.63	0.35	5.04	2.44	0.71	2.74	1.38	0.33	2
OWS 0.5 B	13	9-10	3/8	5.71	0.91	1.81	0.81	0.43	6.61	2.95	0.81	2.91	1.42	0.47	4
OWS 1 B	22	11-13	1/2	5.75	1.12	2.24	0.98	0.47	6.87	3.15	0.98	4.53	1.89	0.55	5
OWS 2 B	28	14-16	5/8	6.93	1.38	2.76	1.18	0.59	8.31	3.78	1.22	5.30	2.24	0.71	9
OWS 3 B	44	18-19	3/4	8.27	1.57	3.15	1.38	0.63	9.84	4.21	1.50	6.30	2.76	0.83	15
OWS 4 B	61	20-22	7/8	9.35	1.87	3.74	1.61	0.71	11.22	4.84	1.73	7.34	3.03	0.94	22
OWS 5 B	83	23-26	1	10.83	2.17	4.33	2.01	0.87	12.99	5.43	2.01	8.33	3.27	1.08	33
OWS 6 B	99	27-29	1 1/8	12.20	2.56	5.12	2.24	0.98	14.76	6.30	2.24	9.11	3.58	1.18	46
OWS 7 B	121	30-32	1 1/4	13.78	2.87	5.75	2.48	1.10	16.65	6.50	2.48	10.47	4.25	1.30	68
OWS 8 B	138	34-36	1 3/8	15.75	2.91	5.83	2.52	1.10	18.66	7.28	2.76	11.73	4.57	1.38	82
OWS 9 B	165	37-39	1 1/2	17.72	3.15	5.59	2.76	1.18	20.87	7.91	3.03	13.31	5.12	1.50	112
OWS 10 B	187	40-42	1 5/8	19.69	3.43	6.30	2.99	1.30	23.11	8.23	2.99	14.67	5.51	1.61	141
OWS 11 B	248	43-48	1 7/8 - 2	21.65	3.94	7.32	3.50	1.54	25.59	9.33	3.50	16.06	5.75	1.89	212
OWS 12 B	309	49-52	2	25.20	4.13	8.07	3.74	1.81	29.33	10.35	3.98	17.72	6.30	2.09	287
OWS 13 B	397	54-58	2 1/4	25.98	4.92	9.84	4.25	2.13	30.91	11.73	4.49	18.50	6.61	2.28	397
OWS 14 B	468	60-68	2 1/2	32.87	5.31	10.63	4.76	2.36	38.19	12.99	5.00	19.69	6.93	2.56	606
OWS 15 B	507	72-76	3	39.37	5.91	11.81	5.24	2.99	45.28	14.96	5.75	21.65	9.61	2.76	970
OWS 16 B	689	81-86	3 1/4 - 3 3/8	43.31	5.91	11.81	5.51	3.11	49.21	15.63	6.26	26.38	10.24	3.15	1124

MBL = Minimum Breaking Load

The standard finish of our sockets is blue. Hot dipped galvanized is also available. Socket range OWS 0.25 until OWS 0.5 is delivered with galvanized finish, other finishes are available upon request. All sockets are provided with an EN 10204-2.1 declaration of conformity, EN 10204-3.1 material certificate and can be provided with a 2006/42/EC declaration where applicable. Meets performance requirements of API 2C.

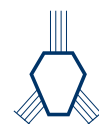

ROPEBLOCK

TAILGRIP OPEN WEDGE SOCKETS WITH PIN

QUENCHED AND TEMPERED CAST STEEL

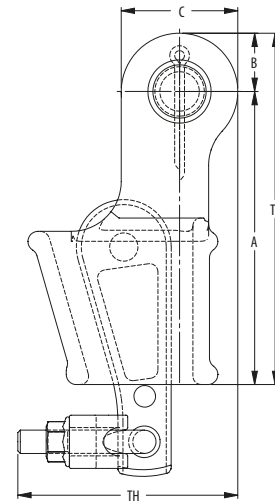
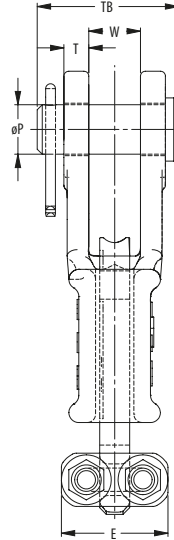
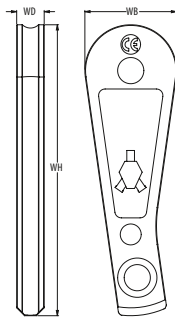

Model No.	MBL (UStons)	for wire ϕ		Dimensions (inch)													Weight (lbs)
		(mm)	(inch)	A	B	C	E	ϕP	T	TH	TL	TB	W	WH	WB	WD	
OWS-TG 0.5 P	13	9-10	$\frac{3}{8}$	5.71	0.91	1.81	1.57	0.81	0.43	2.99	6.61	2.48	0.81	5.12	1.42	0.47	4
OWS-TG 1 P	22	11-13	$\frac{1}{2}$	5.75	1.12	2.24	2.17	0.98	0.47	3.94	6.87	2.64	0.98	6.69	1.89	0.55	5
OWS-TG 2 P	28	14-16	$\frac{5}{8}$	6.93	1.38	2.76	2.52	1.18	0.59	4.92	8.31	3.35	1.22	7.66	2.24	0.71	9
OWS-TG 3 P	44	18-19	$\frac{3}{4}$	8.27	1.57	3.15	2.68	1.38	0.63	5.59	9.84	3.74	1.50	8.74	2.76	0.83	15
OWS-TG 4 P	61	20-22	$\frac{7}{8}$	9.35	1.87	3.74	2.91	1.61	0.71	6.46	11.22	4.33	1.73	9.86	3.03	0.94	22
OWS-TG 5 P	83	23-26	1	10.83	2.17	4.33	3.31	2.01	0.87	7.44	12.99	5.04	2.01	10.79	3.27	1.08	33
OWS-TG 6 P	99	27-29	$1\frac{1}{8}$	12.20	2.56	5.12	3.74	2.24	0.98	8.54	14.76	5.59	2.24	11.48	3.58	1.18	46
OWS-TG 7 P	121	30-32	$1\frac{1}{4}$	13.78	2.87	5.75	4.13	2.48	1.10	9.37	16.65	6.10	2.48	13.74	4.25	1.30	68

MBL = Minimum Breaking Load

The standard finish of our sockets is blue. Hot dipped galvanized is also available. Socket range OWS 0.25 until OWS 0.5 is delivered with galvanized finish, other finishes are available upon request. All sockets are provided with an EN 10204-2.1 declaration of conformity, EN 10204-3.1 material certificate and can be provided with a 2006/42/EC declaration where applicable. Meets performance requirements of API 2C.

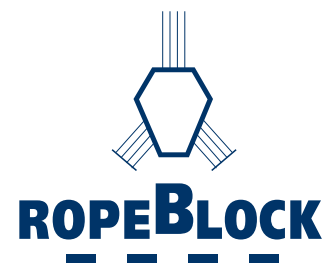

TAILGRIP OPEN WEDGE SOCKETS WITH BOLT AND NUT

QUENCHED AND TEMPERED CAST STEEL

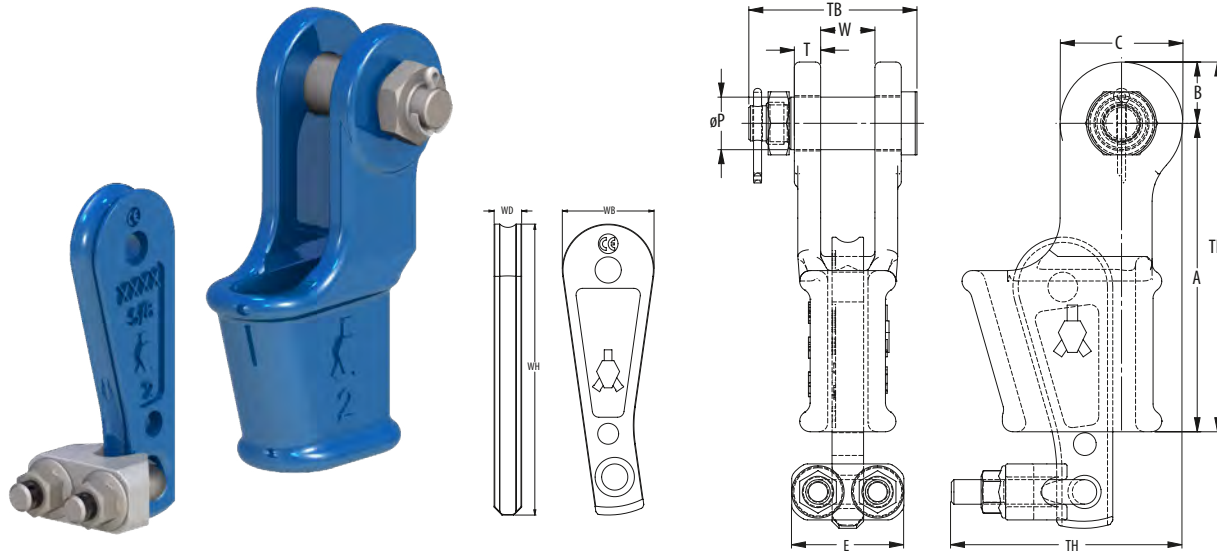

Model No.	MBL (UStons)	for wire ϕ		Dimensions (inch)													Weight (lbs)
		(mm)	(inch)	A	B	C	E	ϕP	T	TH	TL	TB	W	WH	WB	WD	
OWS-TG 0.5 B	13	9-10	$\frac{3}{8}$	5.71	0.91	1.81	1.57	0.81	0.43	2.99	6.61	2.48	0.81	5.12	1.42	0.47	4
OWS-TG 1 B	22	11-13	$\frac{1}{2}$	5.75	1.12	2.24	2.17	0.98	0.47	3.94	6.87	2.64	0.98	6.69	1.89	0.55	5
OWS-TG 2 B	28	14-16	$\frac{5}{8}$	6.93	1.38	2.76	2.52	1.18	0.59	4.92	8.31	3.35	1.22	7.66	2.24	0.71	9
OWS-TG 3 B	44	18-19	$\frac{3}{4}$	8.27	1.57	3.15	2.68	1.38	0.63	5.59	9.84	3.74	1.50	8.74	2.76	0.83	15
OWS-TG 4 B	61	20-22	$\frac{7}{8}$	9.35	1.87	3.74	2.91	1.61	0.71	6.46	11.22	4.33	1.73	9.86	3.03	0.94	22
OWS-TG 5 B	83	23-26	1	10.83	2.17	4.33	3.31	2.01	0.87	7.44	12.99	5.04	2.01	10.79	3.27	1.08	33
OWS-TG 6 B	99	27-29	1 $\frac{1}{8}$	12.20	2.56	5.12	3.74	2.24	0.98	8.54	14.76	5.59	2.24	11.48	3.58	1.18	46
OWS-TG 7 B	121	30-32	1 $\frac{1}{4}$	13.78	2.87	5.75	4.13	2.48	1.10	9.37	16.65	6.10	2.48	13.74	4.25	1.30	68

MBL = Minimum Breaking Load

The standard finish of our sockets is blue. Hot dipped galvanized is also available. Socket range OWS 0.25 until OWS 0.5 is delivered with galvanized finish, other finishes are available upon request. All sockets are provided with an EN 10204-2.1 declaration of conformity, EN 10204-3.1 material certificate and can be provided with a 2006/42/EC declaration where applicable. Meets performance requirements of API 2C.

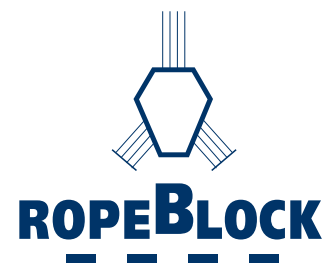

TAILGRIP OPEN WEDGE UTILITY SOCKET WITH PIN QUENCHED AND TEMPERED CAST STEEL

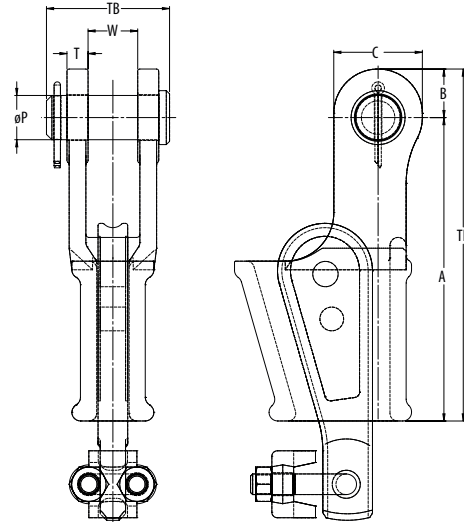
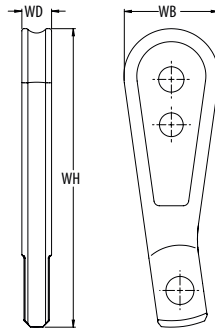

Model No.	MBL (UStons)	for wire ø		Dimensions (inch)											Weight (lbs)	
		(mm)	(inch)	A	B	C	øP	T	TL	TB	W	WH	WB	WD		
OWS-U 4.10 P	■	13	10	3/8	5.75	1.06	1.94	1.00	0.50	6.81	2.93	1.00	5.99	1.91	0.44	5
OWS-U 4.11 P	■	13	11	7/16	5.75	1.06	1.94	1.00	0.50	6.81	5.93	1.00	6.59	1.76	0.53	5
OWS-U 4.13 P	■	13	13	1/2	5.75	1.06	1.94	1.00	0.50	6.81	2.93	1.00	6.65	1.76	0.53	5
OWS-U 5.13 P	■	22	13	1/2	7.69	1.50	3.00	1.25	0.63	9.19	3.65	1.41	7.85	1.92	0.75	9
OWS-U 5.14 P	■	22	14	5/16	7.69	1.50	3.00	1.25	0.63	9.19	3.65	1.41	7.57	2.00	0.69	9
OWS-U 5.16 P	■	22	16	5/8	7.69	1.50	3.00	1.25	0.63	9.19	3.65	1.41	7.63	2.00	0.69	9
OWS-U 6.16 P	■	38	16	5/8	8.46	1.50	3.00	1.25	0.57	9.96	3.74	1.50	7.68	2.36	0.83	13
OWS-U 6.19 P	■	38	19	3/4	8.46	1.50	3.00	1.25	0.57	9.96	3.74	1.50	7.68	2.36	0.83	13
OWS-U 7-22 P	■	38	22	7/8	9.63	1.63	3.26	1.25	0.66	11.26	3.25	1.31	10.59	2.12	1.06	17
OWS-U 7-26 P	■	66	26	1	9.63	1.63	3.26	1.25	0.66	11.26	3.25	1.31	10.59	1.88	1.06	17
OWS-U 8A.16 P	■	38	16	5/8	8.98	1.54	2.87	1.63	0.77	10.51	4.53	1.81	8.84	2.95	0.83	19
OWS-U 8A.19 P	■	38	19	3/4	8.98	1.54	2.87	1.63	0.77	10.51	4.53	1.81	8.84	2.95	0.83	18
OWS-U 8.22 P	■	66	22	7/8	11.06	1.77	3.23	1.63	0.77	12.83	4.49	1.81	10.89	3.46	1.08	28
OWS-U 8.26 P	■	66	26	1	11.06	1.77	3.23	1.63	0.77	12.83	4.49	1.81	10.79	3.27	1.08	28
OWS-U 10.28 P	■	99	28	1 1/8	13.74	2.20	4.33	1.63	0.89	15.94	4.72	1.81	13.82	4.41	1.30	53
OWS-U 10.32 P	■	99	32	1 1/4	13.74	2.20	4.33	1.63	0.89	15.94	4.72	1.81	13.74	4.25	1.30	53
OWS-U 11.28 P	■	99	28	1 1/8	14.00	2.34	4.50	2.50	1.06	16.34	6.53	2.62	14.26	4.76	1.09	61
OWS-U 11.32 P	■	99	32	1 1/4	14.00	2.34	4.50	2.50	1.06	16.34	6.53	2.62	15.20	4.62	1.19	65

MBL = Minimum Breaking Load

The standard finish of our sockets is blue. Hot dipped galvanized is also available. Socket range OWS 0.25 until OWS 0.5 is delivered with galvanized finish, other finishes are available upon request. All sockets are provided with an EN 10204-2.1 declaration of conformity, EN 10204-3.1 material certificate and can be provided with a 2006/42/EC declaration where applicable. Meets performance requirements of API 2C.

- : Smallest wire rope size
- : Intermediate wire rope size
- : Largest wire rope size

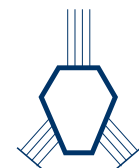

ROPEBLOCK

CLOSED WEDGE SOCKETS QUENCHED AND TEMPERED CAST STEEL

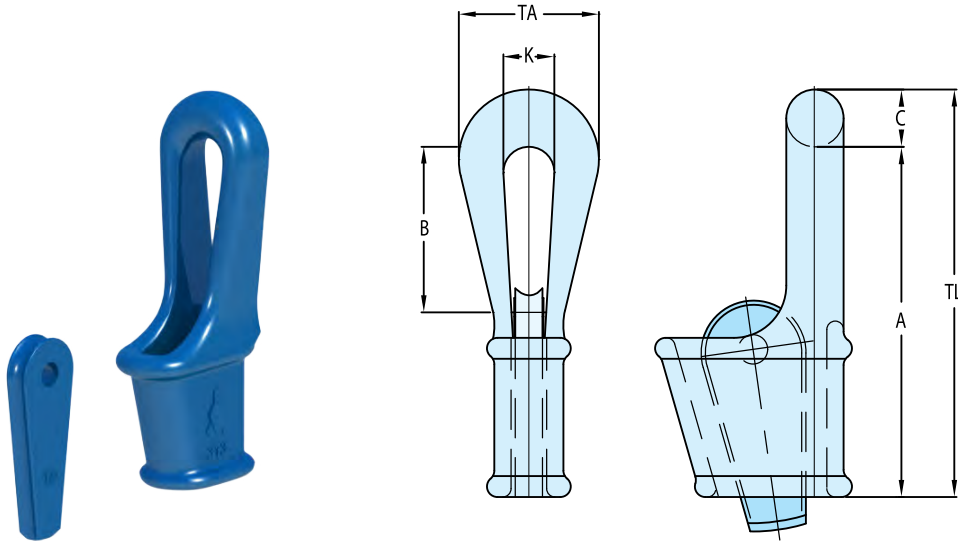

MODEL NR.	MBL (USTONS)	FOR WIRE Ø		DIMENSIONS (INCH)						WEIGHT (LBS)
		MM	INCH	A	B	C	K	TA	TL	
CWS 303	44	18-19	¾	8 1¼	3 1½	1 ½	1 ¼	3 ¾	10	15
CWS 304	61	20-22	7/8	8 ¾	4 1½	1 ½	1 7/8	4 ½	10 ½	20
CWS 305	83	24-26	1	11 7/16	5 ½	1 1½	2 ¾	4 1½	13 ¾	31
CWS 306	99	27-29	1 ½	12 13/16	5 1½	2 ¾	2 ¾	6	15 ¾	49
CWS 307	121	30-32	1 ¼	14 ¾	6 5/16	2 11/16	2 15/16	6 ½	16 7/8	66
CWS 308	138	34-36	1 ¾	15 ¾	7 1/16	2 11/16	2 15/16	6 ½	18 7/16	84
CWS 309	165	37-39	1 ½	19 1¼	9 7/16	2 13/16	3 ½	7 5/16	22 ½	108
CWS 310	187	40-42	1 5/8	23 5/8	12 3/16	3 ½	3 9/16	8 ¼	26 ¾	143
CWS 311	248	43-48	1 ¾ - 1 7/8	25 3/16	12 13/16	3 9/16	3 15/16	8 7/8	28 ¾	220
CWS 312	309	49-52	2	28 3/8	14 ¾	3 15/16	4 5/16	9 5/8	32 5/16	331
CWS 313	397	54-58	2 ¼	30 ½	15 ¾	4 5/16	4 ¾	10 7/16	34 13/16	353
CWS 314	468	61-64	2 ½	35 7/16	18 ½	4 15/16	5 ½	11 13/16	40 3/8	507
CWS 315	507	72-76	3	39 3/8	16 13/16	5 ½	5 7/8	13	44 ½	794
CWS 316	689	81-86	3 ¼ - 3 5/8	44 5/16	21 5/8	5 5/16	6 ½	14 3/16	49 5/8	937

MBL = Minimum Breaking Load

The standard finish of our sockets is blue. Hot dipped galvanized is also available. All sockets are provided with an EN 10204-2.1 declaration of conformity, EN 10204-3.1 material certificate and can be provided with a 2006/42/EC declaration where applicable. Meets performance requirements of API 2C.

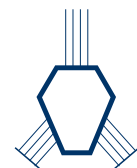

ROPEBLOCK

PORT INDUSTRY SOCKETS WITH BOLT AND NUT QUENCHED AND TEMPERED CAST STEEL

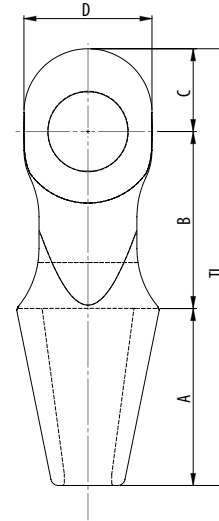
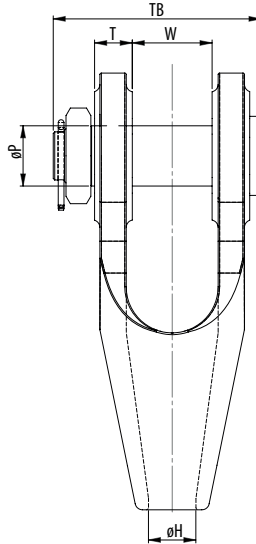

MODEL NR.	MBL (USTONS)	FOR WIRE Ø		DIMENSIONS (INCH)										WEIGHT (LBS)
		MM	INCH	A	B	C	D	Ø H	Ø P	T	TL	TB	W	
OSS G5 B	132	28-30	1 1/8	5,39	5,31	2,17	1,97	1,42	1,99	1,30	12,87	6,77	2,48	24
OSS G6 B	165	31-34	1 1/4 - 1 3/8	6,10	5,91	2,36	4,33	1,65	2,17	1,46	16,38	7,76	2,76	35
OSS G7 B	187	35-38	1 3/8 - 1 1/2	6,93	6,69	2,76	4,72	1,85	2,38	1,61	16,38	8,46	3,15	49
OSS G8 B	248	39-43	1 1/2 - 1 3/4	7,80	7,48	3,15	5,31	2,05	2,78	1,81	18,43	9,53	3,54	62
OSS G9 B	309	44-54	1 3/4 - 2 1/8	9,25	9,25	4,33	6,69	2,48	3,15	1,97	22,83	10,87	4,17	130
OSS G10 B	397	50-60	2 1/4 - 2 1/2	10,43	9,65	4,72	7,48	2,83	3,58	2,17	24,80	9,29	4,96	143

MBL = Minimum Breaking Load

The standard finish of our sockets is blue. Hot dipped galvanized is also available. Socket range OSS 196 until OSS 100 is delivered with galvanized finish, other finishes are available upon request. All sockets are provided with an EN 10204-2.1 declaration of conformity, EN 10204-3.1 material certificate and can be provided with a 2006/42/EC declaration where applicable.

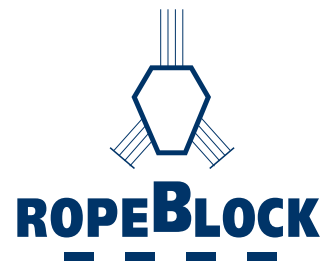
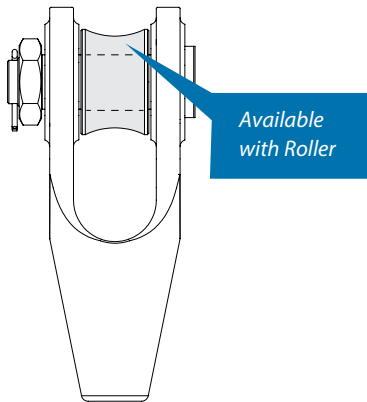

PORT INDUSTRY SOCKETS WITH PIN

QUENCHED AND TEMPERED CAST STEEL

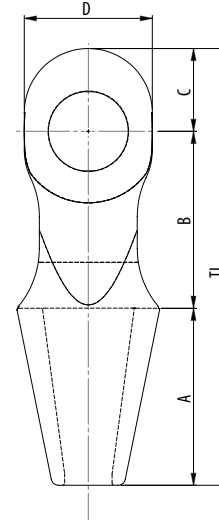
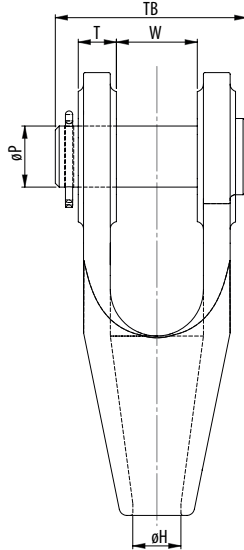

MODEL NR.	MBL (USTONS)	FOR WIRE Ø		DIMENSIONS (INCH)										WEIGHT (LBS)
		MM	INCH	A	B	C	D	ØH	ØP	T	TL	TB	W	
OSS G5 P	132	28-30	1 ¹ / ₈	5,39	5,31	2,17	1,97	1,42	1,99	1,30	12,87	6,77	2,48	24
OSS G6 P	165	31-34	1 ¹ / ₄ - 1 ³ / ₈	6,10	5,91	2,36	4,33	1,65	2,17	1,46	365	7,76	2,76	35
OSS G7 P	187	35-38	1 ³ / ₈ - 1 ¹ / ₂	6,93	6,69	2,76	4,72	1,85	2,38	1,61	16,38	8,46	3,15	49
OSS G8 P	248	39-43	1 ¹ / ₂ - 1 ³ / ₄	7,80	7,48	3,15	5,31	2,05	2,78	1,81	18,43	9,53	3,54	62
OSS G9 P	309	44-54	1 ³ / ₄ - 2 ¹ / ₈	9,25	9,25	4,33	6,69	2,48	3,15	1,97	22,83	10,87	4,17	130
OSS G10 P	397	50-60	2 ¹ / ₄ - 2 ¹ / ₂	10,43	9,65	4,72	7,48	2,83	3,58	2,17	24,80	9,29	4,96	143

MBL = Minimum Breaking Load

The standard finish of our sockets is blue. Hot dipped galvanized is also available. Socket range OSS 196 until OSS 100 is delivered with galvanized finish, other finishes are available upon request. All sockets are provided with an EN 10204-2.1 declaration of conformity, EN 10204-3.1 material certificate and can be provided with a 2006/42/EC declaration where applicable.

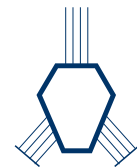
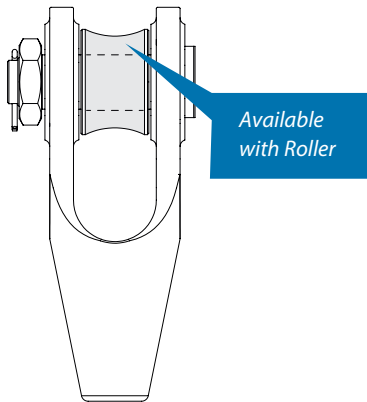

ROPEBLOCK

OPEN SPELTER SOCKETS JIS WITH BOLT QUENCHED AND TEMPERED CAST STEEL

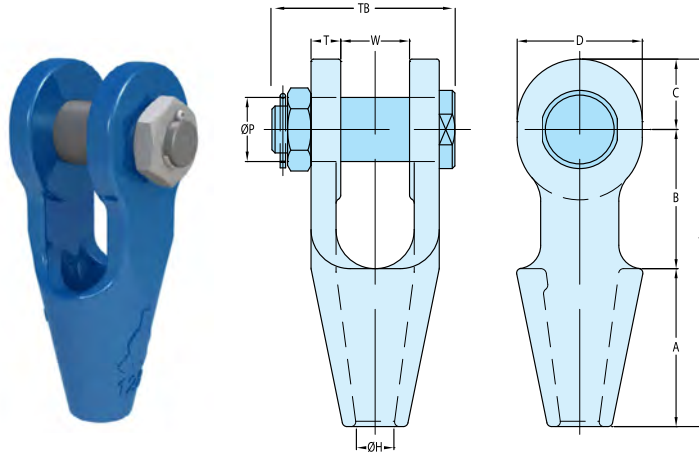

MODEL NR.	MBL (USTONS)	FOR WIRE Ø		DIMENSIONS (INCH)										WEIGHT (LBS)
		MM	INCH	A	B	C	D	Ø H	Ø P	T	TL	TB	W	
OSS 100-J20-B30	31	20	¾	3 ½	3	1 ⅞	2 ¾	1 ⅜	1 ⅜	⅝	8 ⅛	4 ⅜	1 ½	6.6
OSS 104-J22-B34	39	22,4	7/8	4	3 ½	1 ¾	3 ⅞	1 ⅝	1 ⅜	¾	9 ¼	4 ⅜	1 ¾	9.7
OSS 108-J24-B37	45	24	1	4 ½	4	2 ⅜	4 ⅞	1 ⅞	1 ⅞	7/8	10 ⅜	5 ⅞	2	18
OSS 108-J25-B40	57	25	1	4 ½	4	2 ⅜	4 ⅞	1 ⅞	1 ⅞	7/8	10 ⅜	5 ⅞	2	18
OSS 111-J28-B43	62	28	1 ⅛	5	4 ½	2 ⅞	4 ½	1 ¼	1 ⅞	1	12 ⅞	6 ⅞	2 ¼	25
OSS 111-J30-B46	76	30	1 ⅛	5	4 ½	2 ⅞	4 ½	1 ¼	1 ⅞	1	12 ⅞	6 ⅞	2 ¼	25.6
OSS 115-J32-B48	76	31,5	1 ¼ - 1 ⅜	5 ½	5	2 ⅜	4 ⅞	1 ½	1 ⅞	1 ⅞	13 ⅞	6 ⅞	2 ½	33
OSS 115-J34-B52	97	33,5	1 ¼ - 1 ⅜	5 ½	5	2 ⅜	4 ⅞	1 ½	2 ⅞	1 ⅞	13 ⅞	6 ⅞	2 ½	33.5
OSS 118-J36-B56	104	35,5	1 ½	6	6 ⅜	3 ⅞	5 ⅞	1 ⅞	2 ⅞	1 ⅞	15 ½	7 ⅞	3	48.5

MBL = Minimum Breaking Load

The standard finish of our sockets is blue. Hot dipped galvanized is also available.

Socket range OSS 196 until OSS 100 is delivered with galvanized finish, other finishes are available upon request. All sockets are provided with an EN 10204-2.1 declaration of conformity, EN 10204-3.1 material certificate and can be provided with a 2006/42/EC declaration where applicable.

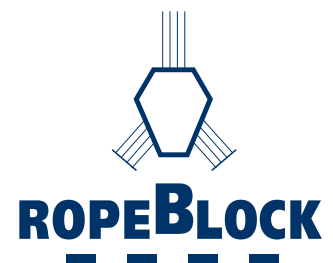

SPILL BOOM



BOOM SPECIFICATIONS

STANDARD STYLE

HEAVY-DUTY STYLE

	DIMENSIONS (INCHES)			DIMENSIONS (INCHES)	
	4" X 6"	6" X 12"	12" X 24" (HB)	6" X 12" (TC)	12" X 24" (TC) (HB)
FREEBOARD	4	6	12	7	13
DRAFT	6	12	24	12	24
FLOTATION LOG DIAMETER	4	6	12	6	12
BUOYANCY POUNDS PER FOOT	5.2	11.8	47.3	11.8	47.3
FABRIC					
BALLAST (GALVANIZED CHAIN)	1/4	1/4	3/8	1/4	3.8
TOP TENSION (GALVANIZED CABLE)	N	N	N	5/16	5/16
FABRIC STRENGTH	9,000#	13,000#	25,000#	13,000#	25,000#
BOTTOM TENSION STRENGTH	4,700#	4,700#	9,800#	4,700#	9,800#
TOP TENSION STRENGTH	N	N	N	9,800#	9,800#
WEIGHT PER FOOT	1.54#	1.96#	3.76#	2.16#	3.95#
STORAGE PER 100 FOOT (CU.FT.)	14	32	102	34	106

CLOSED CELL, FLEXIBLE OIL RESISTANT FOAM FLOTATION LOG THERMALLY SEALED IN POCKET (STANDARD)

NYLON HANDHOLD (OPTIONAL)

DOUBLE LAYER OF FABRIC IN LOG POCKET FOR ADDED STRENGTH AND LONGEVITY (OPTIONAL)

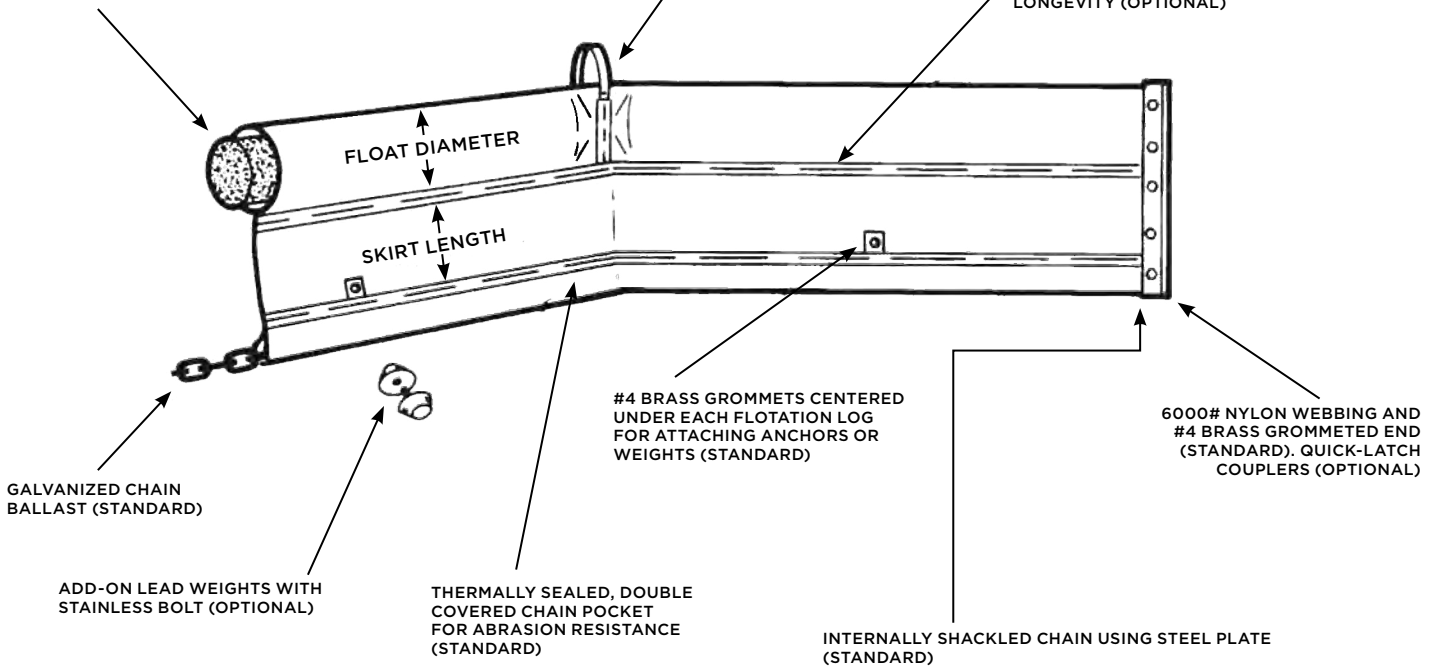

OPTIONAL FEATURES.

- Jaton or Jaton Plus Fabric.
- Extra grommets.
- Stainless steel grommets instead of brass.
- Lead bar ballast instead of chain.
- Double layer of fabric in log pocket.
- Short flotation logs for reel storage.
- Section lengths 6' to 300'.

OPTIONAL ACCESSORIES.

- Quick-latch couplers.
- Flex couplers.
- Tow/tie-off bridles.
- Bulkhead connectors.
- Add-on lead ballast weights (3-1/4#).
- Hand loops.
- Quick-latch repair coupler.
- Fabric repair kit.
- Anchor systems.

VARIOUS COMBINATIONS OF FLOTATION DIAMETERS, SKIRT LENGTHS, SIZES OF CHAIN BALLAST, AND SIZES OF TOP TENSION CABLE ARE AVAILABLE UPON REQUEST. ALL BOOMS CAN BE MANUFACTURED IN ANY LENGTHS TO FIT SPECIFIC REQUIREMENTS.

STANDARD BOOM

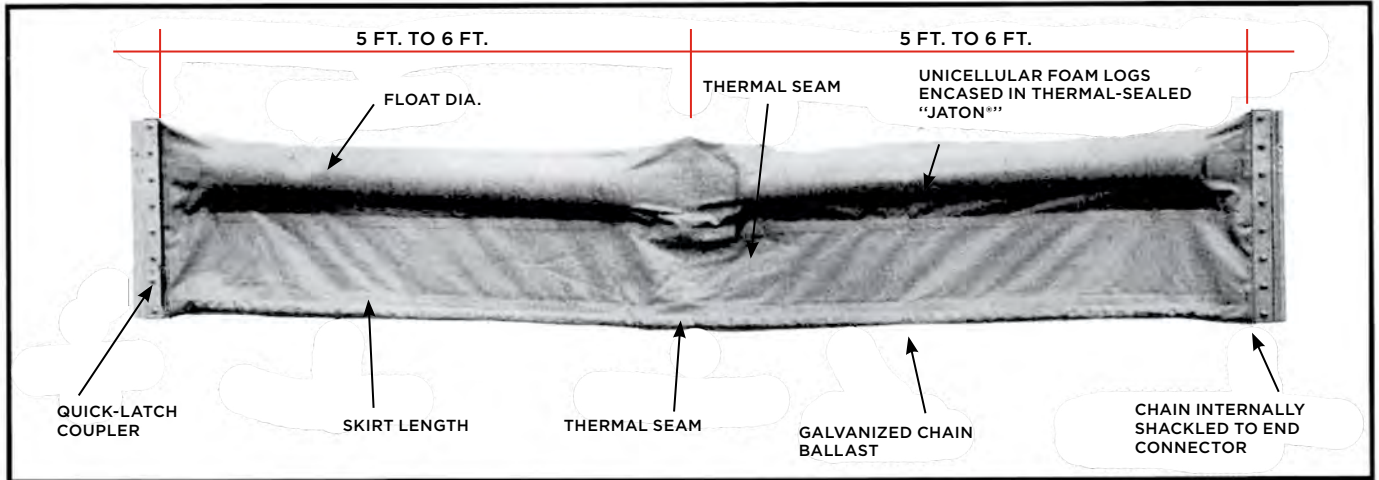

ACCESSORIES AVAILABLE



"Quick-Latch" Coupling and Tow Bridle for fast boom section makeup.



"Flexible" Coupling. For economical semipermanent application.

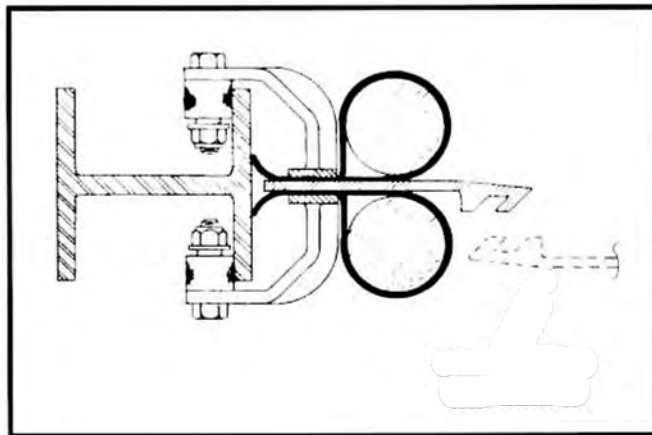

"Hitching-Post" Bulkhead Connector, free floating to allow boom to rise and fall with water level.

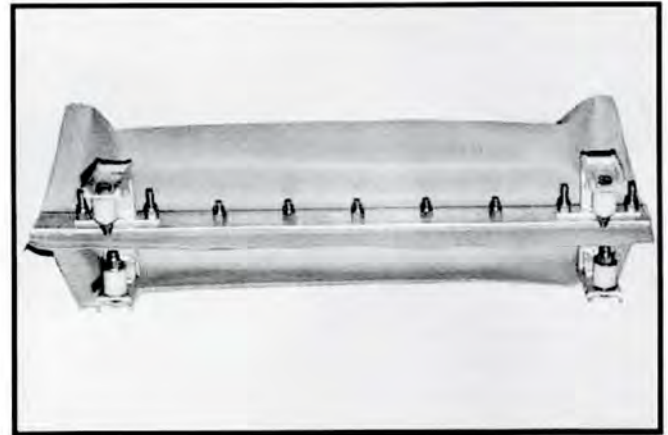

"Hitching-Post" Bulkhead Connector, as shown in engineering drawing at the left (Note lock design.)

22-OZ. JATON® FABRIC IS STANDARD

TOWING

**WE'LL GIVE YOU SOMETHING TO HOLD ON TO...
EQUIPMENT FOR EMERGENCY TOWING.**

CHAIN

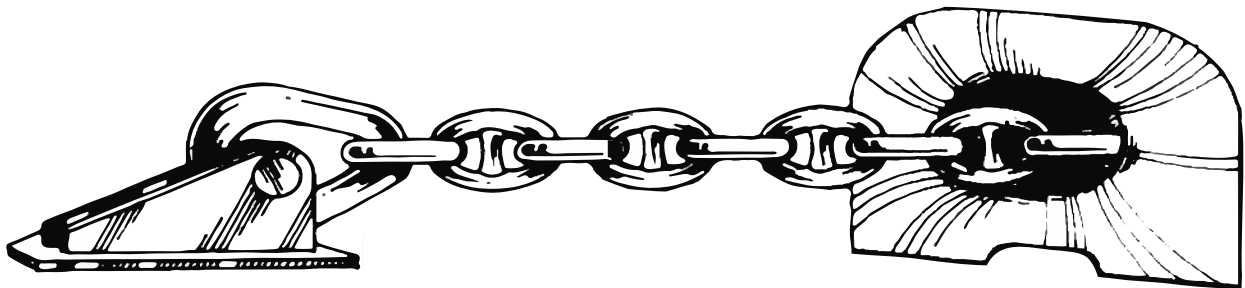

SMIT BRACKET

PANAMA CHOCK

**WE OFFER A COMPLETE STOCK OF EQUIPMENT FOR EMERGENCY
TOWING ARRANGEMENTS, SUCH AS SMIT TOWING BRACKETS,
PANAMA CHOCKS, CHAFING CHAINS, SEA-LINK TOWING SHACKLES
AND SEA-LINK TOWING PLATES.**

SMIT BRACKET WITH ABS CERTIFICATION SWL 200 TON

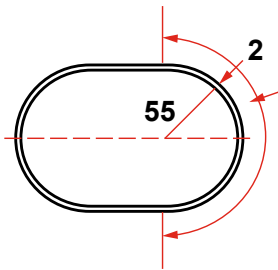
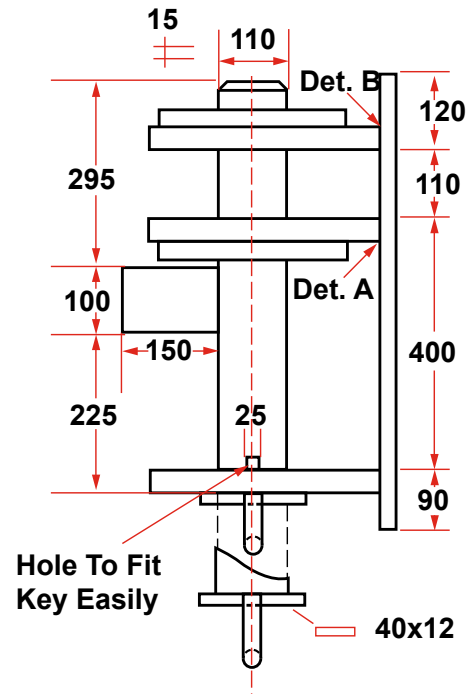
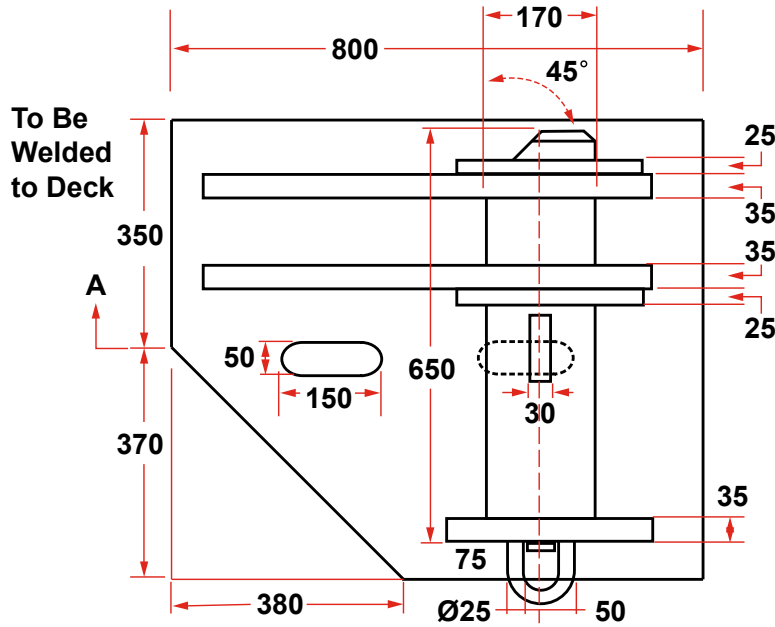

AT LEAST THIS PART OF BOLT AND HOLES TO BE MACHINED

APPROX. WEIGHT 375 KG EACH

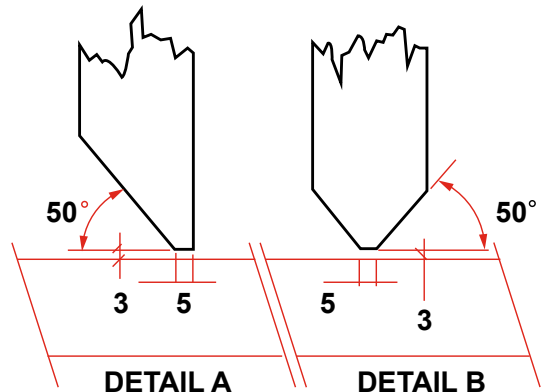
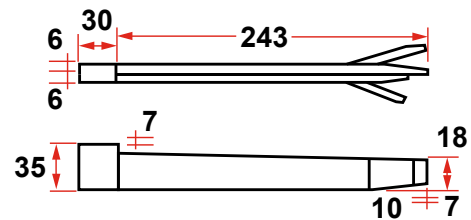
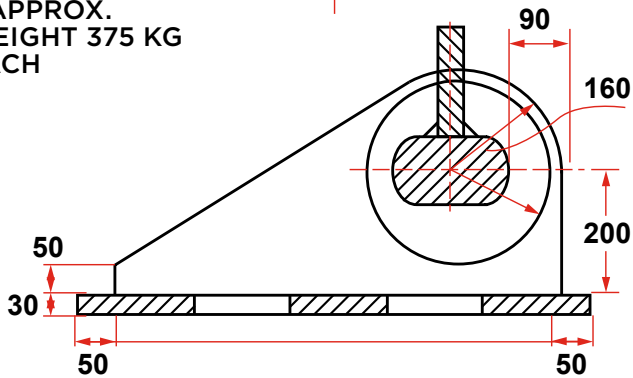

SEA-LINK HEAVY LIFT INDUSTRIAL AND MARINE TOWING SHACKLES

MADE WITH PRIDE IN THE USA

ANCHOR PATTERN – REGULAR JAW

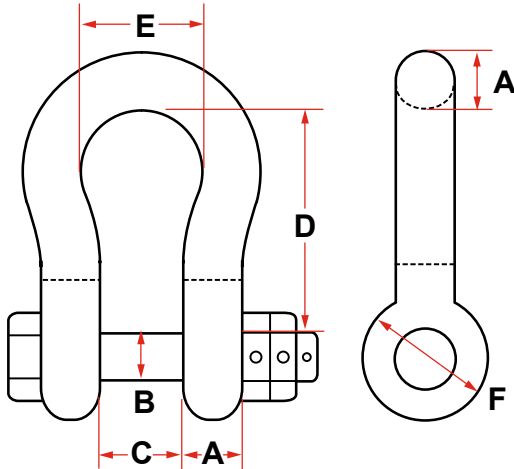

SIZE (A)	WORKING LOAD LIMIT IN TONS	PIN DIAM. IN INCHES (B)	JAW WIDTH INCHES (C)	DIMENSIONS (INCHES)			APPROX. WT. EACH IN POUNDS
				D	E	F	
1-1/2	31	1-3/4	2-3/8	5-3/4	3-7/8	3-1/2	20
1-3/4	41	2	2-7/8	7	5	4-1/4	23
2	52	2-1/4	3-1/4	7-3/4	5-3/4	4-5/8	41
2-1/4	67	2-1/2	4-1/4	9-1/4	6-1/2	5	67
2-1/2	82	2-3/4	4-1/2	10-1/2	7-1/2	5-3/4	88
2-3/4	104	3	4-1/2	11	7-3/4	6-1/8	112
3	123	3-1/4	5	13	8-1/2	6-1/2	133
3-1/2	150	3-3/4	5-3/4	15	9	8-1/4	250
4	200	4-1/4	6-1/2	16	11	9-1/8	358

JAW TOLERANCE

* Anchor Size 1-1/2 - 3 Inches = (+/-).125
* Anchor Size 3-1/2 - 4 Inches = (+/-).250

REACH TOLERANCE

* Anchor Size 1-1/2 - 2-1/2 Inches = (+/-).500
* Anchor Size 2-3/4 - 4 Inches = (+/-).750

SAFETY

* 5:1 Safety Factor

CHAIN PATTERN – REGULAR JAW

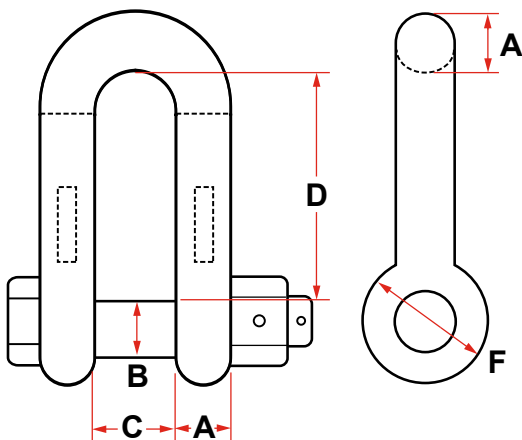

SIZE (A)	WORKING LOAD LIMIT IN TONS	PIN DIAM. IN INCHES (B)	JAW WIDTH INCHES (C)	DIMENSIONS (INCHES)		APPROX. WT. EACH IN POUNDS
				D	F	
1-1/2	31	1-3/4	2-3/8	5-1/2	3-1/2	19
1-3/4	41	2	2-7/8	6-3/4	4-1/4	22
2	52	2-1/4	3-1/4	7-3/4	4-5/8	36
2-1/4	67	2-1/2	4-1/4	9-1/4	5	62
2-1/2	82	2-3/4	4-1/2	10-1/2	5-3/4	86
2-3/4	104	3	4-1/2	11	6-1/8	110
3	123	3-1/4	5	13	6-1/2	125
3-1/2	150	3-3/4	5-3/4	15	8-1/4	218
4	200	4-1/4	6-1/2	16	9-1/8	310

JAW TOLERANCE

* Anchor Size 1-1/2 - 3 Inches = (+/-).125
* Anchor Size 3-1/2 - 4 Inches = (+/-).250

REACH TOLERANCE

* Anchor Size 1-1/2 - 2-1/2 Inches = (+/-).500
* Anchor Size 2-3/4 - 4 Inches = (+/-).750

SAFETY

* 5:1 Safety Factor

AVAILABLE WITH SINGLE NUT OR DOUBLE NUT PINS.

SEA-LINK HEAVY LIFT INDUSTRIAL AND MARINE TOWING SHACKLES (WIDE JAW)

MADE WITH PRIDE IN THE USA

ANCHOR PATTERN — WIDE JAW

SIZE (A)	WORKING LOAD LIMIT IN TONS	PIN DIAM. IN INCHES (B)	JAW WIDTH INCHES (C)	DIMENSIONS (INCHES)			APPROX. WT. EACH IN POUNDS
				D	E	F	
1-1/2	22	1-3/4	4-3/16	8-1/8	6-1/4	3-1/2	28
1-3/4	30	2	5	9-3/8	6-7/8	4-1/4	40
2	40	2-1/4	5-3/4	10-1/2	8-1/8	4-5/8	55
2-1/4	48	2-1/2	6-1/4	11-1/2	8-7/8	5	75
2-1/2	55	2-3/4	6-1/2	12-3/8	9-3/8	5-3/4	106
2-3/4	68	3	7	12-3/4	9-3/4	6-1/8	138
3	80	3-1/4	7-1/4	13	10	6-1/2	157
3-1/2	120	3-3/4	9-1/4	15-1/2	12-1/4	8-1/4	274

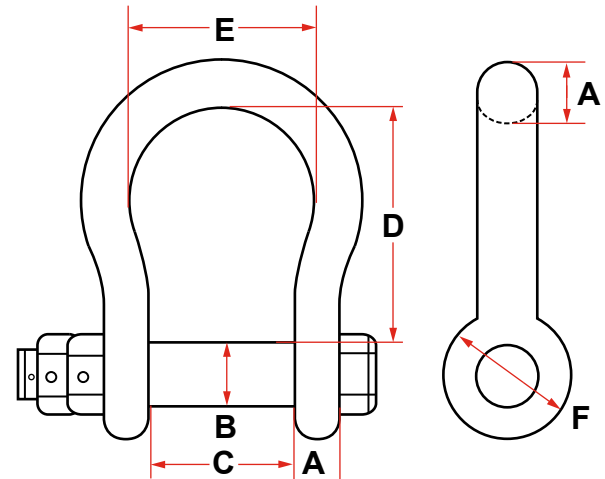

JAW TOLERANCE

* Anchor Size 1-1/2 - 3 Inches = (+/-).125)
* Anchor Size 3-1/2 Inches = (+/-).250)

REACH TOLERANCE

* Anchor Size 1-1/2 - 2-1/2 Inches = (+/-).500)
* Anchor Size 2-3/4 - 3-1/2 Inches = (+/-).750)

SAFETY

* 5:1 Safety Factor

CHAIN PATTERN — WIDE JAW

SIZE (A)	WORKING LOAD LIMIT IN TONS	PIN DIAM. IN INCHES (B)	JAW WIDTH INCHES (C)	DIMENSIONS (INCHES)		APPROX. WT. EACH IN POUNDS
				D	F	
1-1/2	22	1-3/4	4-3/16	8-1/8	3-1/2	28
1-3/4	30	2	5	9-3/8	4-1/4	45
2	40	2-1/4	5-3/4	10-1/2	4-5/8	60
2-1/4	48	2-1/2	6-1/4	11-1/2	5	71
2-1/2	55	2-3/4	6-1/2	12-3/8	5-3/4	112
2-3/4	68	3	7	12-3/4	6-1/8	127
3	80	3-1/4	7-1/4	13	6-1/2	165
3-1/2	120	3-3/4	9-1/4	15-1/2	8-1/4	278

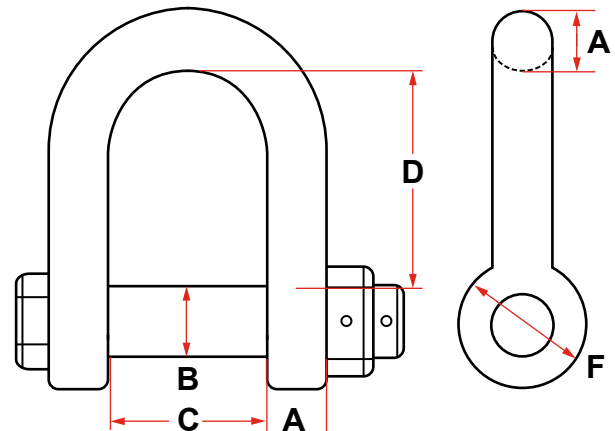

JAW TOLERANCE

* Anchor Size 1-1/2 - 3 Inches = (+/-).125)
* Anchor Size 3-1/2 Inches = (+/-).250)

REACH TOLERANCE

* Anchor Size 1-1/2 - 2-1/2 Inches = (+/-).500)
* Anchor Size 2-3/4 - 3-1/2 Inches = (+/-).750)

SAFETY

* 5:1 Safety Factor

AVAILABLE WITH SINGLE NUT OR DOUBLE NUT PINS.

3" SEA-LINK TOWING SHACKLE (ELONGATED)

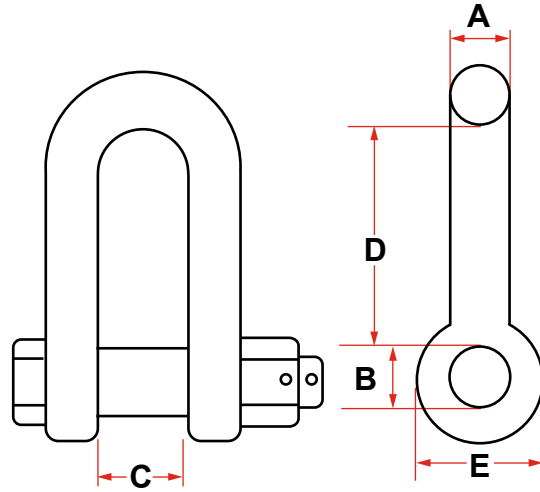

SAFE WORKING LOAD 115 TONS

DIMENSIONS (INCHES)	
A	3
B	3-1/4
C	5-1/2
D	16-1/4

SEA-LINK TOW PLATES WITH ABS CERTIFICATION

NUMBER 1

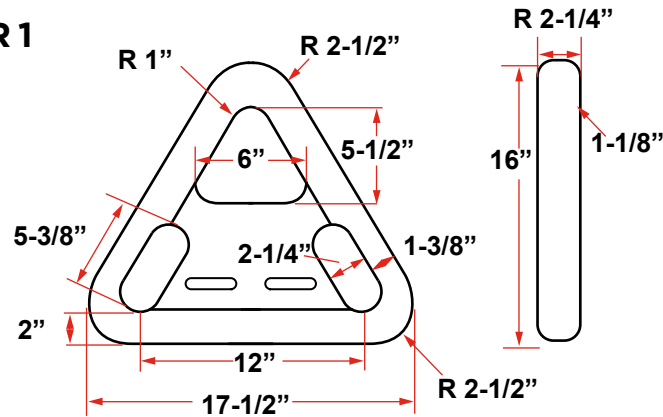

NUMBER 2

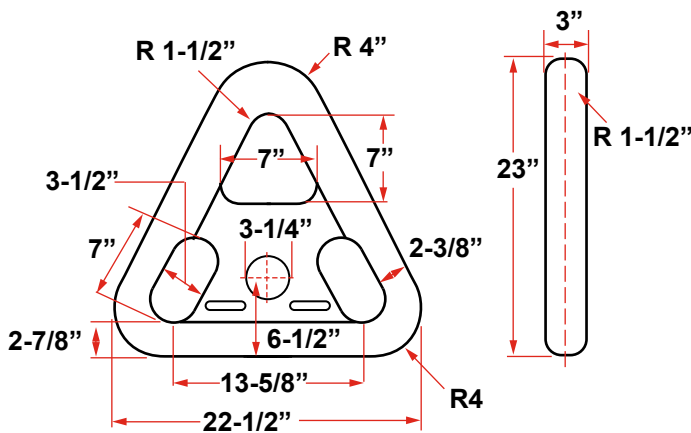

NUMBER 3

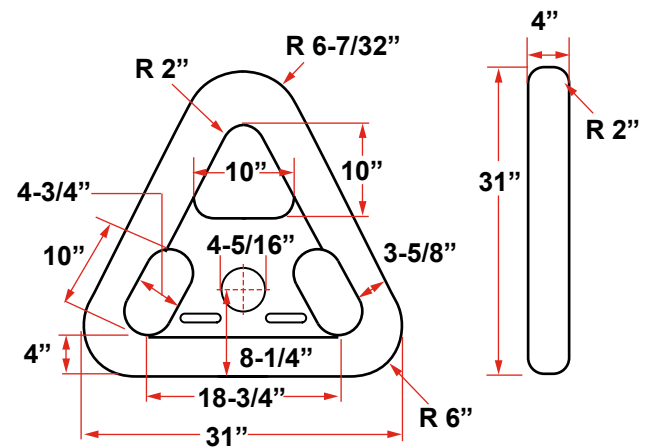

All dimensions in inches and pounds unless otherwise indicated.

TOW PLATE SPECIFICATIONS			
	NO. 1	NO. 2	NO. 3
SHACKLE SIZES	1-1/2" - 2"	2-1/4" - 3"	3-1/2" - 4"
DIMENSIONS	17-1/2" x 16"	22-1/2" x 23"	31" x 31"
WEIGHT	75	202	485
PROOF TEST	300,000	485,000	624,000

Approximate dimensions shown above. Contact us for specific dimensions, as they may differ between manufacturers.

TOWING BRIDAL ASSEMBLY

1. SEA-LINK TOWING SHACKLE
2. SEA-LINK TOWING PLATE
3. STUD LINK ANCHOR CHAIN / G3

