

# CORDAGE





## THREE STRAND & EIGHT STRAND - STANDARD LAY ROPES

### SPECIFICATIONS



MARINE LINES



INDUSTRIAL LINES



FISHING LINES

SIZE (INCHES)		POLYPRO		NYLON		COMBO		MANILA		WORKING LOADS
DIA.	CIRC.	MIN. TENSILE STRENGTH	LBS. PER 600 FT.	MIN. TENSILE STRENGTH	LBS. PER 600 FT.	MIN. TENSILE STRENGTH	LBS. PER 600 FT.	MIN. TENSILE STRENGTH	LBS. PER 600 FT.	SPLICED WORKING LOAD RATIO
3/16"	5/8"	650	4	880	6	-	-	405	9	10.1
1/4"	3/4"	1,125	7	1,468	9	1,200	10	540	12	10.1
5/16"	1"	1,710	11	2,295	15	1,870	15	900	17	10.1
3/8"	1 1/8"	2,430	17	3,240	21	2,700	22	1,215	25	10.1
7/16"	1 1/4"	3,150	23	4,320	30	3,500	28.8	1,575	32	10.1
1/2"	1 1/2"	3,780	28	5,670	39	4,400	39	2,385	45	9.1
9/16"	1 3/4"	4,590	37	7,200	50	5,200	46	3,105	62	8.1
5/8"	2"	5,580	45	8,910	63	6,100	55	3,960	80	8.1
3/4"	2 1/4"	7,650	64	12,780	87	8,400	75	4,860	100	7.1
13/16"	2 1/2"	9,900	76	17,000	102	11,200	88	5,850	117	7.1
7/8"	2 3/4"	10,350	90	17,280	120	11,125	105	6,930	135	7.1
1"	3"	12,825	108	22,230	156	13,175	131	8,100	162	7.1
1 1/16"	3 1/4"	14,400	122	25,200	174	14,775	147	9,450	187	7.1
1 1/8"	3 1/2"	16,000	143	28,260	204	16,325	165	10,800	216	7.1
1 1/4"	3 3/4"	19,350	162	34,830	240	19,900	198	12,150	251	7.1
1 5/16"	4"	21,150	182	38,250	270	21,950	222	13,500	287	7.1
1 1/2"	4 1/2"	27,350	231	48,600	330	28,250	276	16,650	360	7.1
1 5/8"	5"	31,950	286	57,375	399	32,950	336	20,250	446	7.1
1 3/4"	5 1/2"	36,900	342	66,150	498	36,850	408	23,850	537	7.1
2"	6"	46,800	414	84,600	570	48,050	468	27,900	648	7.1
2 1/8"	6 1/2"	52,650	480	95,400	654	53,950	582	-	-	7.1
2 1/4"	7"	59,400	552	107,100	774	59,950	648	-	-	6.1
2 1/2"	7 1/2"	72,000	642	131,400	894	73,550	732	-	-	6.1
2 5/8"	8"	80,500	720	144,000	1,008	80,650	828	-	-	6.1
2 3/4"	8 1/2"	94,500	822	171,000	1,134	95,400	930	-	-	6.1
3"	9"	102,600	918	185,400	1,260	102,900	1,074	57,500	1,380	6.1
3 1/4"	10"	121,500	1,140	224,100	1,584	122,800	1,290	-	-	6.1
3 1/2"	11"	144,000	1,392	267,300	1,872	144,800	1,488	-	-	6.1
4"	12"	171,900	1,656	324,000	2,280	171,000	1,740	-	-	6.1
4 1/4"	13"	198,000	1,920	369,000	2,580	195,800	2,310	-	-	6.1
4 5/8"	14"	252,000	2,190	510,000	3,000	224,800	2,682	-	-	6.1
5"	15"	256,500	2,520	570,000	3,420	254,700	3,078	-	-	6.1

The information contained herein is descriptive only and is presented without warranty. These specifications are the result of tests made on new and unused rope of current manufacture in accordance with the Cordage Institute Standard Test Methods. They do not cover exceptional conditions such as shock load, sustained load, etc. Pounds per 100 feet are "average" for synthetics. The maximum weight is 5% above these figures. Manila approximately 95% of the strength of three standard Manila size for size. Specifications for other ropes, are available on request.

SIZE (INCHES)		APPROX. AVERAGE TENSILE STRENGTH (LBS.)	NET WEIGHT * PER 100 FT. IN POUNDS
DIAMETER	CIRCUMFERENCE		
3/8	1-1/8	4300	3.5
7/16	1-1/4	6000	5.0
1/2	1-1/2	8000	6.7
9/16	1-3/4	10000	8.3
5/8	2	13000	10.5
3/4	2-1/4	16500	14.5
7/8	2-3/4	24500	20.8
1	3	29000	25.8
1-1/16	3-1/4	35000	31.0
1-1/8	3-1/2	39000	35.0
1-1/4	3-3/4	44000	40.0
1-5/16	4	49000	45.0
1-1/2	4-1/2	61500	62.5

## DOUBLE-BRAID NYLON

This line is produced from 100% white nylon fibers in both the cover and core. In commercial fishing, Double-Braid Nylon is recommended for use as Towing Lines, Brailing Lines, Double and Single Falls, and for general all-purpose uses. For pleasure boating uses these ropes are excellent Mooring and Anchor Lines. In the utility industry they are used as Hand Lines and Bull Ropes. Double Braid Nylon is fully spliceable. Subject to +10%, -0% from these figures.

SIZE (INCHES)		APPROX. AVERAGE TENSILE STRENGTH (LBS.)	NET WEIGHT * PER 100 FT. IN POUNDS
DIAMETER	CIRCUMFERENCE.		
3/8	1-1/8	4300	4.5
7/16	1-1/4	6000	6.2
1/2	1-1/2	8000	8.0
9/16	1-3/4	10000	10.5
5/8	2	13000	13.0
3/4	2-1/4	16500	17.5
7/8	2-3/4	24500	25.0
1	3	29000	30.5
1-1/16	3-1/4	35000	36.0
1-1/8	3-1/2	39000	40.0
1-1/4	3-3/4	44000	47.0
1-5/16	4	49000	53.0
1-1/2	4-1/2	61500	67.0

## DOUBLE-BRAID POLYESTER

A line incorporating 100% polyester fibers in both the cover and the core. Double-Braid Polyester is the answer to rugged demands requiring a rope with high strength and low stretch. In the utility field this product has received excellent reception in overhead transmission work for pulling in new and replacement conductors. It is also replacing wire as a Winch Line. Commercial fishermen request it for Purse Lines. Sailing enthusiasts require it for all running rigging. Industry uses it for fabricating rope sling. As with other Double-Braid products, it is fully spliceable. \*Subject to +10%, -0% from these figures.



## MANILA SAFETY LINE SPECIFICATIONS

DIAMETER SIZE (INCHES)	WEIGHT PER 100 FT (LBS.)	MINIMUM BREAKING STRENGTH (LBS.)
7/8	26.5	2700

MANILA SAFETY LINE is engineered for the job. It is a safety line used by tree toppers in lumbering, by high scalers in dam building and construction, and wherever there is an unusual hazard of damage to climbing rope. A BUILT-IN EXTRA MARGIN OF SAFETY makes it very different from regular manila rope. Not only is it a four-strand product, but in the center of the rope there is a heart of wire rope (performed super steel). If the Manila rope is accidentally damaged, the wire adds the margin of safety for the protection of life and limb.

## PLASMA® 12 STRAND

Plasma™ 12 strand is the highest strength synthetic rope available. Plasma™ 12 strand is manufactured from AlliedSignal Spectra® Fiber that has been enhanced by Puget Sound Rope's patented recrystallization process. This process is especially effective in medium to large diameter ropes where strengths are over 50% higher and creep is significantly less than that of standard Spectra® 12 strand.

Plasma™ 12 strand comes standard with a polyurethane finish and is easily spliced using a simple lockstitch type splice or 4-3-2 tuck splice. Its soft, torque free braided construction provides easy handling.

Tensile Strengths are determined in accordance with ASTM test method D 4268-83.

Weights are calculated at linear density under standard preload (200 d<sup>2</sup>) plus 4%.

- Highest strength
- Lowest stretch
- Low creep
- Soft hand
- Torque free
- Easy splicing
- Floats

Specify gravity.....	0.98
Melting point.....	284° F
Critical temp.....	150° F
Coefficient of friction.....	0.09-0.12
Elongation at break.....	4% - 5%
Fiber water absorption.....	0%
UV resistance.....	excellent
Wet abrasion.....	superior
Dry abrasion.....	superior

## SPECTRA® 12 STRAND

Spectra® 12 strand provides very high strength, low stretch and excellent abrasion resistance in a single braid construction.

For the equivalent weight rope it is over 3 times as strong as polyester and has less than one half the elongation.

Spectra® 12 strand comes standard with a polyurethane finish and is easily spliced using a 4-3-2 tuck splice. Its soft, torque free braided constructions provides easy handling.

Tensile Strengths are determined in accordance with ASTM test method 4268-83.

Weights are calculated using the linear density under standard preload (200 d<sup>2</sup>) plus 4%.

- Very Low stretch
- Very High strength
- Soft hand
- Torque free
- Easy splicing
- Floats

Specify gravity.....	0.98
Melting point.....	284° F
Critical temp.....	150° F
Coefficient of friction.....	0.09-0.12
Elongation at break.....	6% - 8%
Fiber water absorption.....	0%
UV resistance.....	excellent
Wet abrasion.....	superior
Dry abrasion.....	superior

NOMINAL DIAMETER (INCHES)	SIZE NUMBER (CIRC.)	APPROXIMATE WEIGHT (LBS./100FT.)	MINIMUM TENSILE STRENGTH (LBS.)
7/16	1-1/4	4.2	21000
1/2	1-1/2	6.4	31300
9/16	1-3/4	7.9	37900
5/8	2	10.6	51400
3/4	2-1/4	13.3	68500
7/8	2-3/4	19.6	92600
1	3	23.4	110000
1-1/8	3-1/2	31.9	147000
1-1/4	3-3/4	36.2	165000
1-5/16	4	41.7	196000
1-1/2	4-1/2	51.7	221000
1-5/8	5	65.7	291000
1-3/4	5-1/2	78.4	314000
2	6	91.4	355000
2-1/8	6-1/2	109.0	428000
2-1/4	7	122.0	481000
2-5/8	8	167.0	560000
3	9	214.0	780000
3-1/4	10	261.0	1000000
3-5/8	11	324.0	1250000
4	12	394.0	1520000

NOMINAL DIAMETER (INCHES)	SIZE NUMBER (CIRC.)	APPROXIMATE WEIGHT (LBS./100FT.)	MINIMUM TENSILE STRENGTH (LBS.)
7/16	1-1/4	4.2	14800
1/2	1-1/2	6.4	22500
9/16	1-3/4	7.9	27700
5/8	2	10.6	36600
3/4	2-1/4	13.3	43200
7/8	2-3/4	19.6	61000
1	3	23.4	72000
1-1/8	3-1/2	31.9	91800
1-1/4	3-3/4	36.2	102600
1-5/16	4	41.7	114300
1-1/2	4-1/2	51.7	141300
1-5/8	5	65.7	167400
1-3/4	5-1/2	78.4	198000
2	6	91.4	225000
2-1/8	6-1/2	109.0	270000
2-1/4	7	122.0	317700
2-1/2	7-1/2	148.0	360000
2-5/8	8	167.0	370800
2-3/4	8-1/2	187.0	405000
3	9	214.0	508500
3-1/4	10	261.0	616500
3-5/8	11	324.0	765000
4	12	394.0	900000

\* Plasma is a trademark of Puget Sound Rope Corp.

\* Spectra is a trademark of Allied Signal Corp.

## POLYESTER 12 PLAIT

Polyester 12 Plait provides high strength, low stretch and excellent abrasion resistance in a unique single braid construction.

Polyester 12 Plait is easily spliced using a standard tuck splice and is 30% stronger than three strand or 8 plait polyester. It's torque free braided construction provides easy handling and prevents kinks and hockles.

Polyester 12 Plait comes standard with an overlay marine finish and is available on special order with a spliceable polyurethane finish in clear or any of six colors.

Tensile Strengths are determined in accordance with ASTM test Method D 4268-83.

Weights are calculated at linear density under standard preload (200 d<sup>2</sup>) plus 5%.

- Low Stretch
- High Strength
- Soft hand
- Torque free
- Easy splicing
- Meets MIL-R-24750

Specify gravity.....	1.38
Melting point.....	482° F
Critical temp.....	350° F
Coefficient of friction.....	0.12-0.15
Elongation at break.....	15% - 20%
Fiber water absorption.....	0% - 1%
UV resistance.....	excellent
Wet abrasion.....	excellent
Dry abrasion.....	excellent

NOMINAL DIAMETER (INCHES)	SIZE NUMBER (CIRC.)	APPROXIMATE WEIGHT (LBS./100FT.)	MINIMUM TENSILE STRENGTH (LBS.)
5/8	2	14.1	12100
3/4	2-1/4	18.7	15800
7/8	2-3/4	28.2	24200
1	3	35.1	27500
1-1/8	3-1/2	41.2	35500
1-1/4	3-3/4	45.9	42100
1-5/16	4	55.0	48200
1-1/2	4-1/2	71.1	59600
1-5/8	5	84.8	72200
1-3/4	5-1/2	98.6	84400
2	6	120.0	101000
2-1/8	6-1/2	141.0	119000
2-1/4	7	160.0	137000
2-1/2	7-1/2	189.0	163000
2-5/8	8	208.0	179000
2-3/4	8-1/2	234.0	202000
3	9	273.0	233000
3-1/4	10	338.0	282000
3-5/8	11	402.0	340000
4	12	486.0	409000

## NYLON DOUBLE BRAID

Nylon Double Braid is the preferred choice for applications requiring high strength with excellent shock absorbing properties. Nylon Double Braid has good resistance to abrasion, unlight and chemicals. Due to its high elongation, nylon is almost always used in applications involving shock loading such as anchor lines and mooring lines.

Nylon Double Braid comes standard with an overlay marine finish and is available on special order with a spliceable polyurethane finish in clear or any of six colors.

- High Stretch
- High Strength
- Excellent shock absorption
- Soft hand
- Torque free
- Meets MIL-R-24050D

Specify gravity.....	1.14
Melting point.....	414° F
Critical temp.....	300° F
Coefficient of friction.....	0.12-.015
Elongation at break.....	30% - 35%
Fiber water absorption.....	3% - 5%
UV resistance.....	good
Wet abrasion.....	excellent
Dry abrasion.....	excellent

SIZE (INCHES)		AVG. LBS./100FT.	STRENGTH	STANDARD PACKAGING		
DIAMETER	CIRC.			LENGTH	BULK CARTON APPROX. WT.	600 FT. SPOOL APPROX. WT.
5/8	2	12	14800	4800	576	72
3/4	2-1/4	15	19000	3600	540	90
7/8	2-3/4	22	28300	2400	528	132
1	3	26	33500	2400	624	156
1-1/8	3-1/2	36	44900	1800	648	216
1-1/4	3-3/4	41	52300	1200	492	246
1-5/16	4	47	58800	1200	564	282
1-1/2	4-1/2	60	74000	600	360	360
1-5/8	5	74	92400	600	444	444
1-3/4	5-1/2	89	110900	600	534	534
2	6	106	131500	600	636	636
2-1/8	6-1/2	124	152800			744
2-1/4	7	144	177000			864
2-1/2	7-1/2	165	201000			990
2-5/8	8	188	231000			1128
2-3/4	8-1/2	212	254000			1272
3	9	238	283000			1428
3-1/4	10	294	319000			1764
3-5/8	11	356	381000			2136
4	12	423	447000			2538
4-1/4	13	497	522000			2982

# DANLINE/MOORING LINES

8-STRAND, POLYPROPYLENE - BLUE

## FEATURES

Low cost general purpose rope that floats and does not absorb water.  
Specific Gravity 0.91.

## APPLICATIONS

General Marine, Mooring, Tie-Up Lines, Towing and Barge Lines.

DIAMETER (INCHES)	CIRCUMFERENCE (INCHES)	WEIGHT PER 100 FEET (POUNDS)	BREAKING STRENGTH (POUNDS)	COIL LENGTH (FEET)
1-5/8	5	41	43,477	220
2	6	71	63,580	220
2-1/4	7	59.47	73,865	220
2-1/2	7-1/2	69.60	85,085	220
2-5/8	8	105.94	97,240	220
3	9	157	126,310	220
3-1/4	10	190	158,000	220
4	12	280	233,750	220



Color: Blue with Yellow Tracer



## MAXIFLEX

### 8-STRAND, POLYESTER/POLYOLEFIN

#### FEATURES

- We hereby confirm that our Maxiflex Ropes are made as per OCIMF Guidelines x2000.
- With 6' canvas covered eyes

#### APPLICATIONS

General Marine, Mooring, Tie-Up Lines, Towing and Barge Lines.

1. Review of Rope Design Specification, Material Specification and Manufacturing Specification.
2. Observing and inspecting the yarn/rope through all stages of manufacture and testing.
3. Random witnessing of yarn twisting and rope through all stages of manufacturing machinery set-ups for the above sizes and production thereof.
4. Witnessing the following tests as required by OMIMF Guidelines 1th edition 2000:
  - a. New Dry and New Wet Break Strength Tests.
  - b. Cyclic Load Tests ( as applicable)
  - c. Elongation and Extension Measurements, with respect to the rope, for both Dry & Wet conditions.
5. Review and Endorsement of all Manufacturing & Test Data.

MAXIFLEX (CIR)	DIAMETER (INCHES)	TENSILE (LBS)	WEIGHT IN LBS
5" X 720'	1-5/8	66,000	430
6" X 720'	2	101,000	621
7" X 720'	2-1/4	138,000	832
7-1/2" X 720'	2-1/2	158,000	984
8" X 720'	2-5/8	182,133	1,090
9" X 720'	3	224,910	1,380
10" X 720'	3-1/4	276,727	1,705
12" X 720'	4	407,000	2,900



Color: White with Red Tracer

## AMSTEEL-BLUE

### FEATURES

Uses Dyneema® SK-75  
 A size-for-size strength replacement for wire rope at only 1/7th the weight  
 Torque-free, very flexible, easy to handle  
 Similar elastic elongation to wire rope  
 Easily inspected or field spliced  
 Floats

### APPLICATIONS

- Winch lines, pull-in lines
- Heavy lifting slings
- Primary vessel mooring lines
- Emergency and seismic tow lines
- Rig tow lines
- Grommets

### SPECIFICATIONS

- Specific Gravity: .98 (floats)
- Elastic Elongation Percentage:  
 At % of break strength
 

10%	0.46%
20%	0.70%
30%	0.96%

DIAMETER (INCHES)	SIZE CIRCUMFERENCE (INCHES)	WEIGHT PER 100 FT. (LBS.)	SRT MBS* (LBS.)	SIZE DIAMETER (MM)	WEIGHT PER 100 M (KILOGRAMS)	SRT MBS* (METRIC TONS)	ISO/BS EN919 MBS (METRIC TONS)
3/16	9/16	1.0	4,900	5	1.5	2.2	2.4
1/4	3/4	1.6	7,700	6	2.4	3.5	3.9
5/16	1	2.7	12,300	8	4.0	5.6	6.2
3/8	1-1/8	3.6	17,600	9	5.4	8.0	8.9
7/16	1-1/4	4.2	21,500	11	6.2	9.8	10.8
1/2	1-1/2	6.4	30,600	12	9.5	13.9	15.4
9/16	1-3/4	7.9	36,500	14	11.8	16.5	18.4
5/8	2	10.2	47,500	16	15.2	21.5	23.9
3/4	2-1/4	13.3	58,000	18	19.8	26.3	29.2
7/8	2-3/4	19.6	81,700	22	29.2	37.1	41.2
1	3	21.8	98,100	24	32.4	44.5	49.4
1-1/16	3-1/4	27.5	118,000	26	40.9	53.6	59.6
1-1/8	3-1/2	31.9	133,000	28	47.5	60.4	67.1
1-1/4	3-3/4	36.2	149,000	30	53.9	67.5	75.0
1-5/16	4	41.8	166,000	32	62.2	75.2	83.6
1-3/8	4-1/8	45.0	185,000	34	67.0	83.9	93.2
1-1/2	4-1/2	51.7	205,000	36	76.9	93.0	103.0
1-5/8	5	65.2	255,000	40	97.0	116.0	128.0
1-3/4	5-1/2	78.4	302,000	44	117.0	137.0	152.0
2	6	87.0	343,000	48	129.0	155.0	173.0
1-1/8	6-1/2	109.0	411,000	52	162.0	186.0	207.0
2-1/4	7	116.0	484,000	56	173.0	219.0	244.0
2-1/2	7-1/2	148.0	529,000	60	220.0	240.0	267.0
2-5/8	8	167.0	595,000	64	248.0	270.0	300.0
2-3/4	8-1/2	187.0	662,000	68	278.0	300.0	333.0
3	9	206.0	748,000	72	307.0	339.0	377.0
3-1/4	10	240.0	906,000	80	357.0	411.0	457.0
3-5/8	11	340.0	1,313,000	88	506.0	596.0	662.0
4	12	380.0	1,637,000	96	566.0	743.0	825.0
4-1/4	13	430.0	1,826,000	104	640.0	828.0	920.0
4-5/8	14	525.0	2,216,000	112	781.0	1005.0	1117.0
5	15	580.0	2,421,000	120	863.0	1098.0	1220.0
5-1/4	16	635.0	2,637,000	128	945.0	1196.0	1329.0
5-1/2	17	695.0	2,865,000	136	1034.0	1300.0	1444.0
6	18	780.0	3,211,000	144	1161.0	1457.0	1618.0
6-1/4	19	880.0	3,581,000	158	1310.0	1624.0	1805.0
6-5/8	20	1015.0	4,104,000	168	1511.0	1862.0	2068.0
7	21	1090.0	4,370,000	178	1622.0	1982.0	2203.0
7-1/4	22	1170.0	4,658,000	184	1741.0	2113.0	2348.0
7-5/8	23	1325.0	5,243,000	194	1972.0	2378.0	2642.0
8	24	1400.0	5,540,000	203	2084.0	2513.0	2792.0



## TYPES OF ROPES

**TWISTED.** All Cordage products are available in the standard three-strand twisted construction. Some specialty items of Manila rope are manufactured in a four-strand construction.



**BRAIDED.** Double-Braid was designed and engineered for advantageous use in the power companies and with the electrical contractors; on commercial fishing vessels; on pleasure crafts and in several industries. The Double-Braid construction is available in 100 percent Nylon, and 100 percent Polyester.



**PLAITED.** These unique hawsers are manufactured in eight-strand construction, having four left laid strands and four right laid strands, paired off, laid parallel and woven together. Plaited lines eliminate hidden stresses arising from kinking and hockling since they will not hockle. The vary nature of this construction is torque free and offers extreme flexibility wet or dry. Plaited ropes are available in 5" circumference and larger.



PROPERTIES OF ROPE	MANILA	NYLON	POLYESTER	POLYPROPYLENE
Strength: Tenacity of dry fiber (in grams/denier):	5-6.0	9.0	8.5	6.5
Suggested maximum rope working load (percentage of Breaking Test):	Varies by diameter size (7% - 10%)	Varies by diameter size (9% - 12%)	Varies by diameter size (7% - 10%)	Varies by diameter size (7% - 10%)
Wet Strength compared to Dry Strength	up to 120%	85-90%	100%	100%
Rope shock absorption ability:	Poor	Excellent	Good	Very Good
Weight: Specific gravity of fibers or filaments:	1.20	1.14	1.38	0.91
Ability to float:	No	No	No	Yes
ROPE STRENGTH/WEIGHT ROTATION (AVG.)	1.0	3.0	2.25	2.5
Elongation: Rope elongation at suggested max. working load.	Low	Very High	Moderately Low	Moderate
Creep (extension-under sustained load):	Very Low	Moderate	Low	High
Water absorption of individual fibers:	High	Moderate	Moderate	Low
Resistance to rot, mildew, deterioration due to marine organisms:	Poor	Excellent	Excellent	Excellent
Chemical Resistance: Effect of acids:	Will disintegrate in hot dilute & cold concentrated acids.	Decomposed by strong mineral acids; resistant to weak acids.	Resistant to most mineral acids; disintegrated by 95% sulfuric acid	Good resistance
Effect of alkalis:	Little resistance	Little or none.	Little effect cold; slowly disintegrated by strong alkalis at boil	High resistance
Effect of organic solvents:	Low resistance: hydrocarbons will remove proactive lubricants on rope	Fair resistance: soluble in some phenotic compounds & 90% formic acid	Generally unaffected: soluble in some phenolic compounds	Soluble in chlorinated hydrocarbons at 160° F
Degradation: Resistance to U.V. in sunlight:	Fair	Good	Excellent	Fair; Black is best
Resistance to aging.	Good, but will lose strength as lubricants dry out.	Excellent	Excellent	Excellent
Rope Abrasion Resistance: Surface:	Good	Very Good	Best	Good
Internal:	Good	Excellent	Best	Good
Melting Point of Rope:	Not applicable	482° F	500° F	330° F
Ability of rope to render, or ease out, smoothly over metal while under load:	Excellent	Poor	Good	Very Poor

## SYNTHETIC ROPE THIMBLES

INCREASES SLING LIFE, PROTECTS THE EYE, CUTS COST. LIGHT WEIGHT, HEAVY DUTY

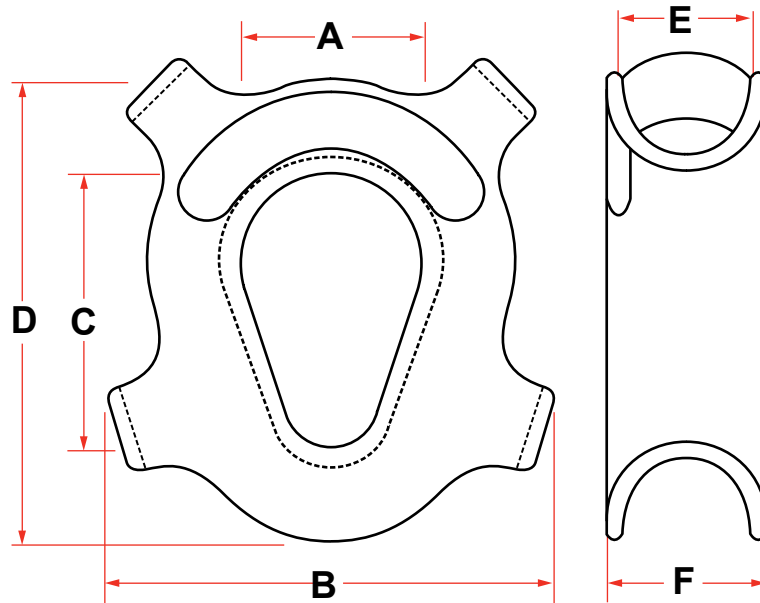

DIMENSIONS AND DATA

ROPE DIA.	ROPE CIRCUM.	A	B	C	D	E	F	APPROX. WT.
IN	IN	IN	IN	IN	IN	IN	IN	LBS
3/8 - 7/16	1-1/8 - 1-1/4	7/8	2-1/16	1-1/2	2-7/16	9/16	3/4	.25
1/2 - 9/16	1-1/2 - 1-3/4	1	2-3/8	1-5/8	2-13/16	11/16	29/32	.45
5/8 - 3/4	2 - 2-1/4	1-1/8	3-1/8	2	3-1/2	7/8	1-1/8	.60
13/16 - 15/16	2-1/2 - 2-3/4	1-1/4	3-3/4	2-15/16	4-3/16	1-1/16	1-3/8	.90
1 - 1-13/16	3 - 3-3/4	2	5-5/16	3-1/2	5-3/8	1-1/2	1-9/16	6
1-1/4 - 1-1/2	4 - 5	3-3/8	7	5-1/8	7-7/8	1-3/4	1-27/32	8
1-7/8 - 2-1/4	6 - 7	3-3/4	9-7/32	5-3/4	9-3/8	2-5/8	3-15/32	11
2-1/2	8	4-1/4	10-7/8	6-1/2	11	3-5/32	3-3/4	18
2-7/8	9	4-3/4	11-5/8	7-5/8	12	3-1/4	4-1/4	26
3-1/4	10	4-7/8	12-1/4	8-1/2	13-9/16	3-1/2	4-3/4	33
3-3/8 - 4	11-12	5-5/8	14-3/4	9-1/2	15-3/4	4-5/8	5-29/32	44
4-1/4 - 4-5/8	13-14	6-1/8	16-1/4	10	16-15/16	5-5/16	6-11/16	57
5 - 5-1/4	15-16	6-1/2	17-3/8	10-1/2	18	5-3/4	7-1/4	68
5-3/8 - 5-3/4	17-18	9	21-13/16	13-1/8	20-1/8	6-1/2	7-7/8	137
6 - 6-3/8	19-20	12	26-3/4	16-1/4	27	7-3/4	9-1/8	231
6-3/4 - 7	21-22	13-7/8	30-3/8	19-3/4	33-3/4	8-1/2	10-1/4	359