

TOWING

**WE'LL GIVE YOU SOMETHING TO HOLD ON TO...
EQUIPMENT FOR EMERGENCY TOWING.**

CHAIN

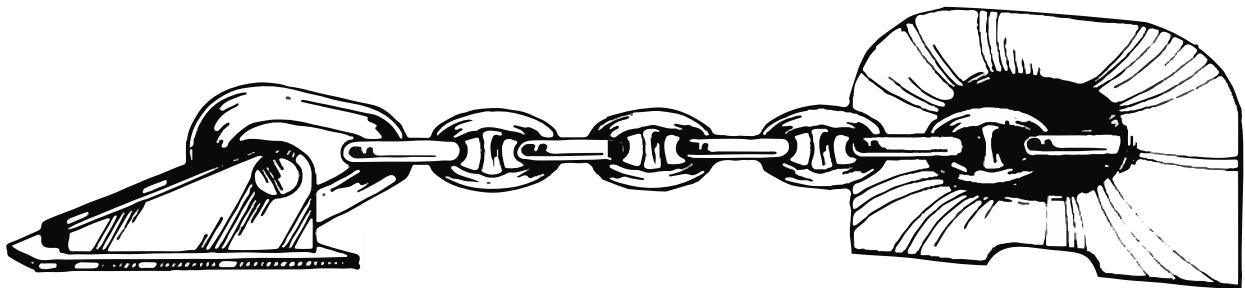

SMIT BRACKET

PANAMA CHOCK

**WE OFFER A COMPLETE STOCK OF EQUIPMENT FOR EMERGENCY
TOWING ARRANGEMENTS, SUCH AS SMIT TOWING BRACKETS,
PANAMA CHOCKS, CHAFING CHAINS, SEA-LINK TOWING SHACKLES
AND SEA-LINK TOWING PLATES.**

SMIT BRACKET WITH ABS CERTIFICATION SWL 100 TON

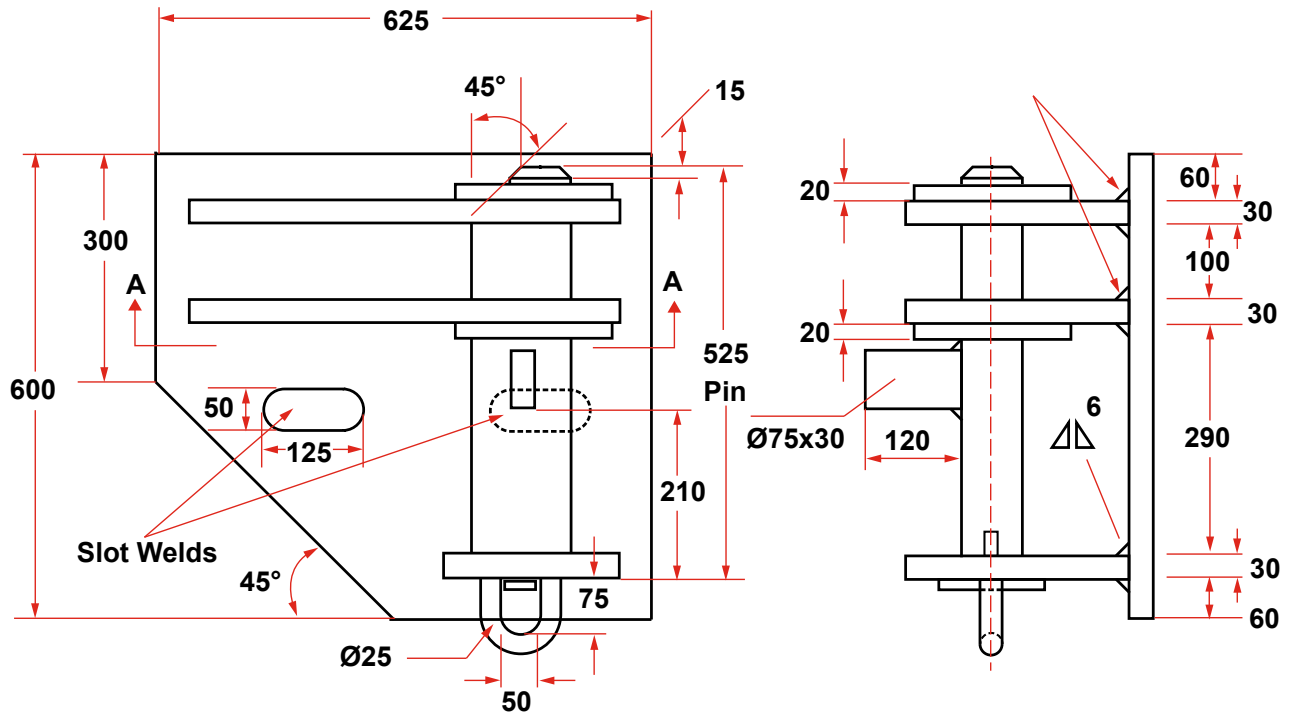

SECTION A-A

APPROX. WEIGHT
195 KG EACH

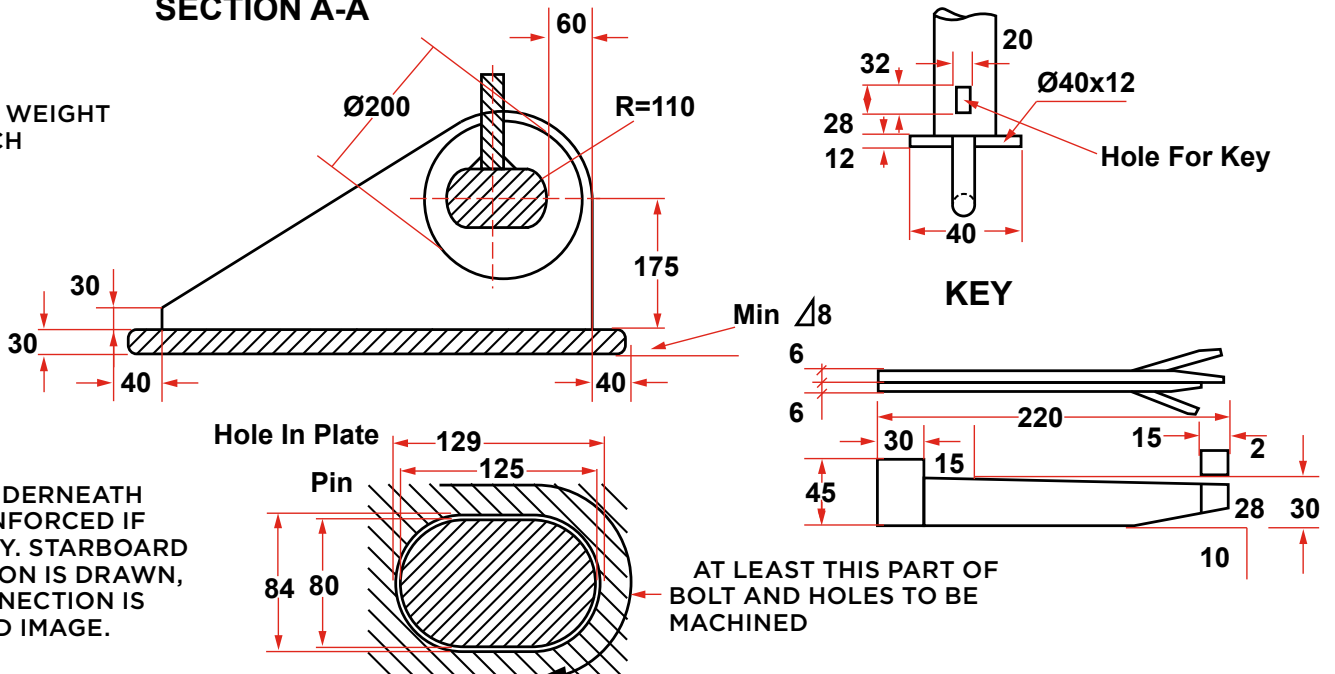

SMIT BRACKET WITH ABS CERTIFICATION SWL 200 TON

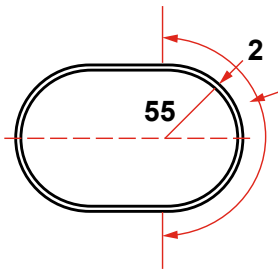
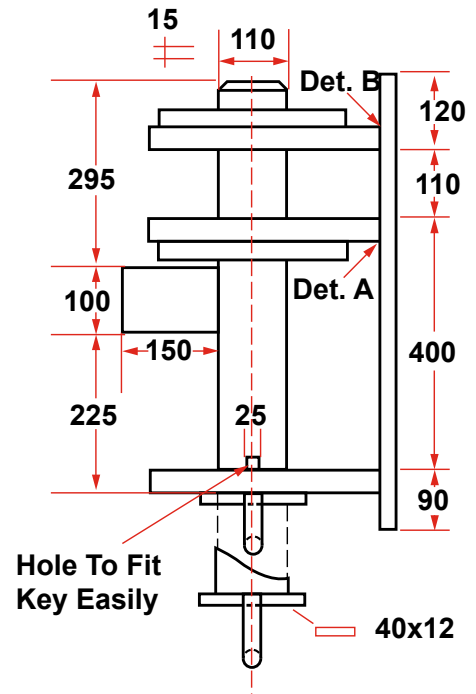
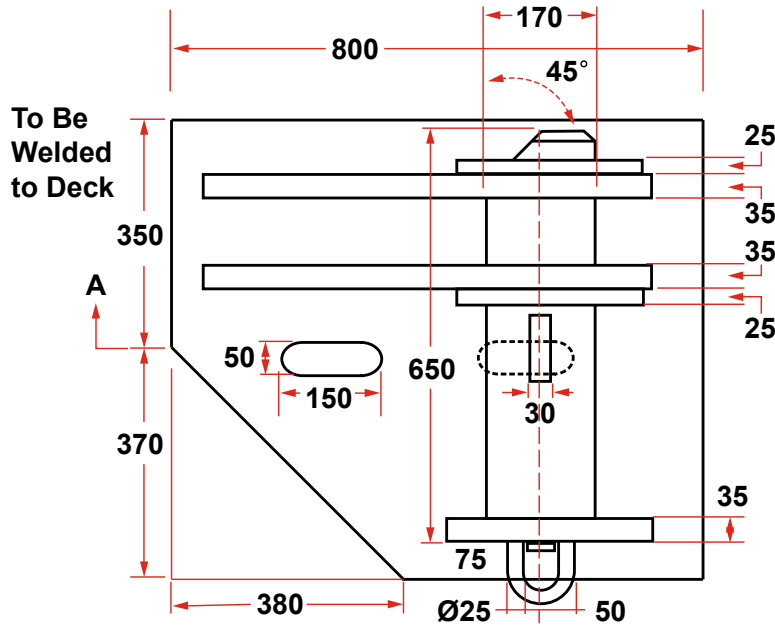

AT LEAST THIS PART OF BOLT AND HOLES TO BE MACHINED

APPROX. WEIGHT 375 KG EACH

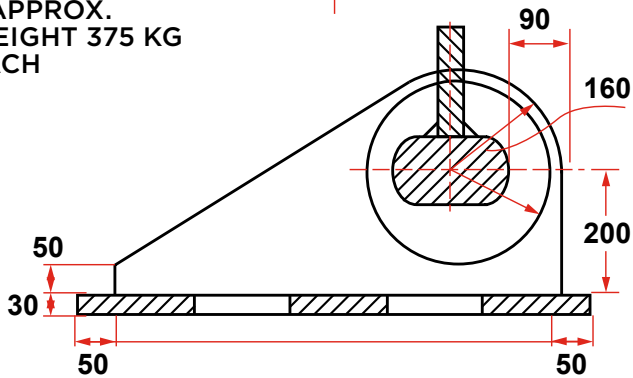

DECK UNDERNEATH TO BE REINFORCED IF NECESSARY. STARBOARD CONNECTION IS DRAWN, PORT CONNECTION IS REFLECTED IMAGE.

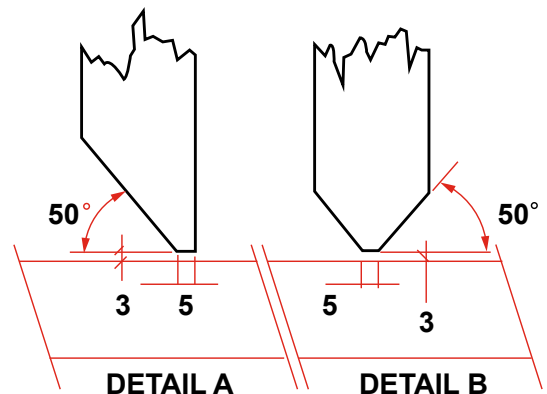
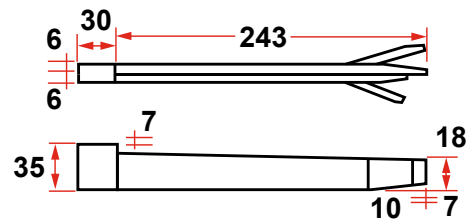

SEA-LINK HEAVY LIFT INDUSTRIAL AND MARINE TOWING SHACKLES

MADE WITH PRIDE IN THE USA

ANCHOR PATTERN – REGULAR JAW

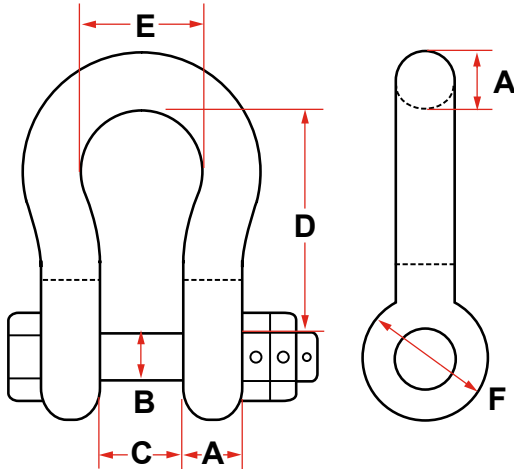

SIZE (A)	WORKING LOAD LIMIT IN TONS	PIN DIAM. IN INCHES (B)	JAW WIDTH INCHES (C)	DIMENSIONS (INCHES)			APPROX. WT. EACH IN POUNDS
				D	E	F	
1-1/2	31	1-3/4	2-3/8	5-3/4	3-7/8	3-1/2	20
1-3/4	41	2	2-7/8	7	5	4-1/4	23
2	52	2-1/4	3-1/4	7-3/4	5-3/4	4-5/8	41
2-1/4	67	2-1/2	4-1/4	9-1/4	6-1/2	5	67
2-1/2	82	2-3/4	4-1/2	10-1/2	7-1/2	5-3/4	88
2-3/4	104	3	4-1/2	11	7-3/4	6-1/8	112
3	123	3-1/4	5	13	8-1/2	6-1/2	133
3-1/2	150	3-3/4	5-3/4	15	9	8-1/4	250
4	200	4-1/4	6-1/2	16	11	9-1/8	358

JAW TOLERANCE

* Anchor Size 1-1/2 - 3 Inches = (+/-).125
* Anchor Size 3-1/2 - 4 Inches = (+/-).250

REACH TOLERANCE

* Anchor Size 1-1/2 - 2-1/2 Inches = (+/-).500
* Anchor Size 2-3/4 - 4 Inches = (+/-).750

SAFETY

* 5:1 Safety Factor

CHAIN PATTERN – REGULAR JAW

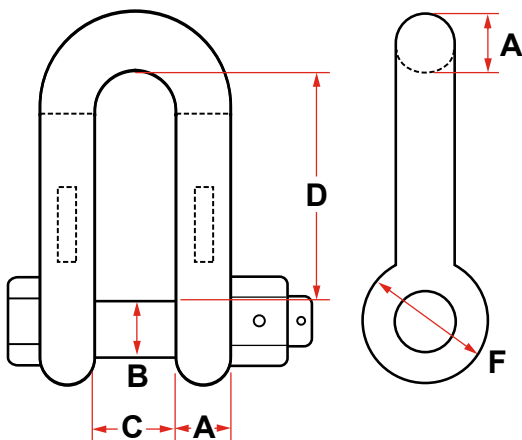

SIZE (A)	WORKING LOAD LIMIT IN TONS	PIN DIAM. IN INCHES (B)	JAW WIDTH INCHES (C)	DIMENSIONS (INCHES)		APPROX. WT. EACH IN POUNDS
				D	F	
1-1/2	31	1-3/4	2-3/8	5-1/2	3-1/2	19
1-3/4	41	2	2-7/8	6-3/4	4-1/4	22
2	52	2-1/4	3-1/4	7-3/4	4-5/8	36
2-1/4	67	2-1/2	4-1/4	9-1/4	5	62
2-1/2	82	2-3/4	4-1/2	10-1/2	5-3/4	86
2-3/4	104	3	4-1/2	11	6-1/8	110
3	123	3-1/4	5	13	6-1/2	125
3-1/2	150	3-3/4	5-3/4	15	8-1/4	218
4	200	4-1/4	6-1/2	16	9-1/8	310

JAW TOLERANCE

* Anchor Size 1-1/2 - 3 Inches = (+/-).125
* Anchor Size 3-1/2 - 4 Inches = (+/-).250

REACH TOLERANCE

* Anchor Size 1-1/2 - 2-1/2 Inches = (+/-).500
* Anchor Size 2-3/4 - 4 Inches = (+/-).750

SAFETY

* 5:1 Safety Factor

AVAILABLE WITH SINGLE NUT OR DOUBLE NUT PINS.

SEA-LINK HEAVY LIFT INDUSTRIAL AND MARINE TOWING SHACKLES (WIDE JAW)

MADE WITH PRIDE IN THE USA

ANCHOR PATTERN — WIDE JAW

SIZE (A)	WORKING LOAD LIMIT IN TONS	PIN DIAM. IN INCHES (B)	JAW WIDTH INCHES (C)	DIMENSIONS (INCHES)			APPROX. WT. EACH IN POUNDS
				D	E	F	
1-1/2	22	1-3/4	4-3/16	8-1/8	6-1/4	3-1/2	28
1-3/4	30	2	5	9-3/8	6-7/8	4-1/4	40
2	40	2-1/4	5-3/4	10-1/2	8-1/8	4-5/8	55
2-1/4	48	2-1/2	6-1/4	11-1/2	8-7/8	5	75
2-1/2	55	2-3/4	6-1/2	12-3/8	9-3/8	5-3/4	106
2-3/4	68	3	7	12-3/4	9-3/4	6-1/8	138
3	80	3-1/4	7-1/4	13	10	6-1/2	157
3-1/2	120	3-3/4	9-1/4	15-1/2	12-1/4	8-1/4	274

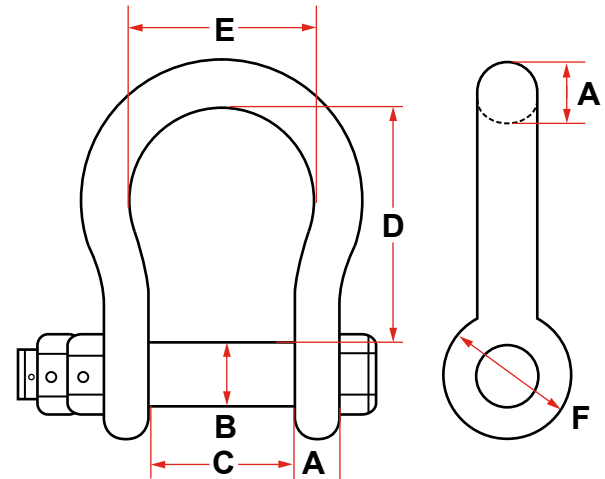

JAW TOLERANCE

* Anchor Size 1-1/2 - 3 Inches = (+/-).125)
* Anchor Size 3-1/2 Inches = (+/-).250)

REACH TOLERANCE

* Anchor Size 1-1/2 - 2-1/2 Inches = (+/-).500)
* Anchor Size 2-3/4 - 3-1/2 Inches = (+/-).750)

SAFETY

* 5:1 Safety Factor

CHAIN PATTERN — WIDE JAW

SIZE (A)	WORKING LOAD LIMIT IN TONS	PIN DIAM. IN INCHES (B)	JAW WIDTH INCHES (C)	DIMENSIONS (INCHES)		APPROX. WT. EACH IN POUNDS
				D	F	
1-1/2	22	1-3/4	4-3/16	8-1/8	3-1/2	28
1-3/4	30	2	5	9-3/8	4-1/4	45
2	40	2-1/4	5-3/4	10-1/2	4-5/8	60
2-1/4	48	2-1/2	6-1/4	11-1/2	5	71
2-1/2	55	2-3/4	6-1/2	12-3/8	5-3/4	112
2-3/4	68	3	7	12-3/4	6-1/8	127
3	80	3-1/4	7-1/4	13	6-1/2	165
3-1/2	120	3-3/4	9-1/4	15-1/2	8-1/4	278

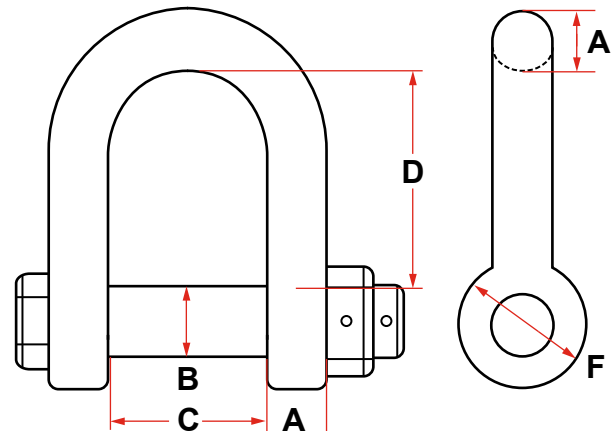

JAW TOLERANCE

* Anchor Size 1-1/2 - 3 Inches = (+/-).125)
* Anchor Size 3-1/2 Inches = (+/-).250)

REACH TOLERANCE

* Anchor Size 1-1/2 - 2-1/2 Inches = (+/-).500)
* Anchor Size 2-3/4 - 3-1/2 Inches = (+/-).750)

SAFETY

* 5:1 Safety Factor

AVAILABLE WITH SINGLE NUT OR DOUBLE NUT PINS.

3" SEA-LINK TOWING SHACKLE (ELONGATED)

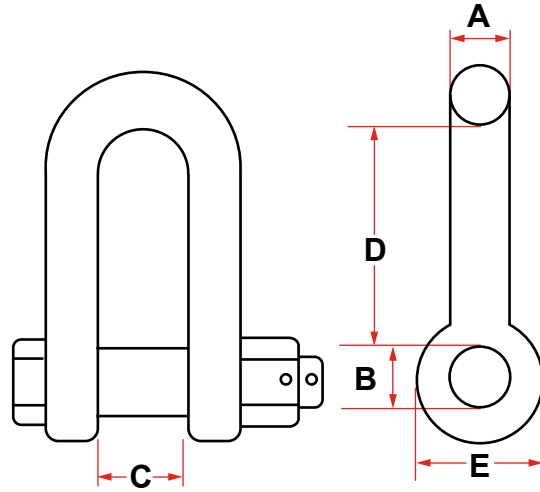

SAFE WORKING LOAD 115 TONS

DIMENSIONS (INCHES)	
A	3
B	3-1/4
C	5-1/2
D	16-1/4

SEA-LINK TOW PLATES WITH ABS CERTIFICATION

NUMBER 1

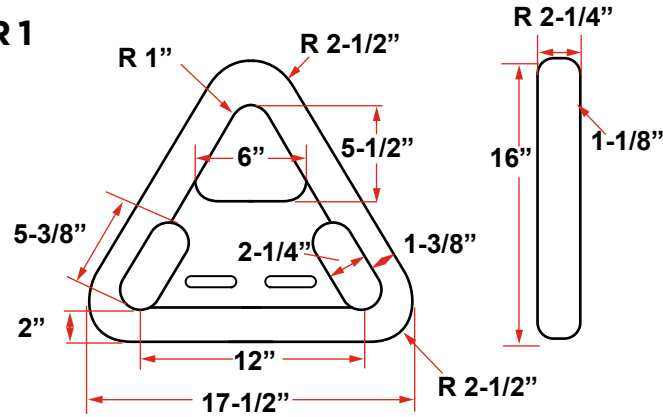

NUMBER 2

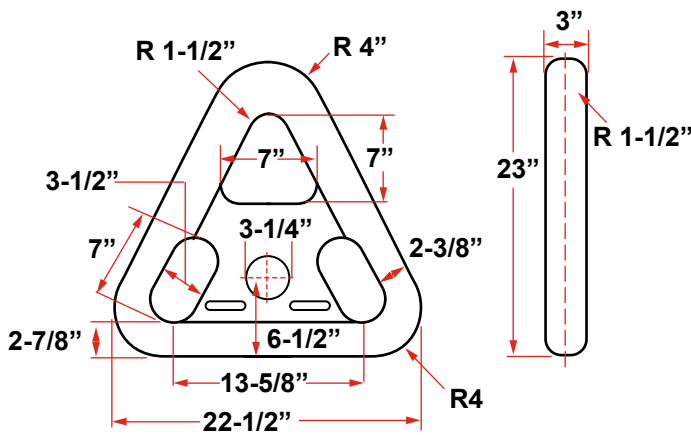

NUMBER 3

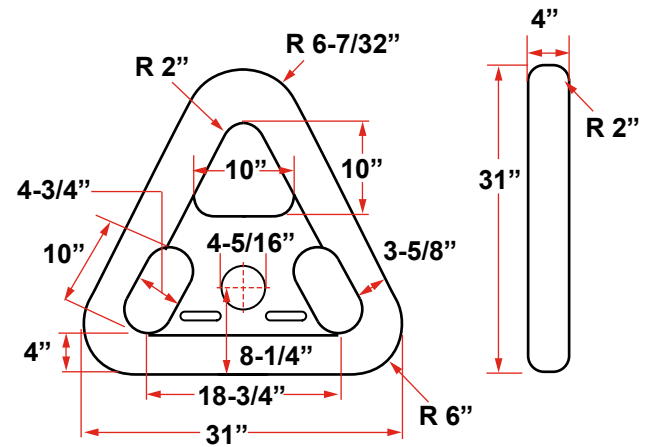

All dimensions in inches and pounds unless otherwise indicated.

TOW PLATE SPECIFICATIONS			
	NO. 1	NO. 2	NO. 3
SHACKLE SIZES	1-1/2" - 2"	2-1/4" - 3"	3-1/2" - 4"
DIMENSIONS	17-1/2" x 16"	22-1/2" x 23"	31" x 31"
WEIGHT	75	202	485
PROOF TEST	300,000	485,000	624,000

Approximate dimensions shown above. Contact us for specific dimensions, as they may differ between manufacturers.

TOWING BRIDAL ASSEMBLY

1. SEA-LINK TOWING SHACKLE
2. SEA-LINK TOWING PLATE
3. STUD LINK ANCHOR CHAIN / G3

